

- **Continuous sample reaction**
  - faster response to changes in sample condition
- **Fully dynamic chemical mixing**
  - guarantees complete chemical reaction
- **Incorporates unique heated block assembly**
  - maintains full temperature control over chemical reaction maximising speed of response
- **Fully automatic programmable two-point calibration**
  - reduces manual intervention keeping maintenance costs to a minimum
- **Large LCD graphics display module**
  - easy to read under all light conditions
- **Comprehensive inbuilt diagnostics**
  - pinpoints maintenance needs
- **Automatic color compensation**
  - eliminates the influence of color
- **Minimal maintenance requirements**
  - 35 days continuous operation without manual intervention



**Cost-effective measurement of phosphate for waste water, plumbo-solvency, boiler water and environmental monitoring**

## Introduction

Many years of continuous experience and innovation in the design and successful application of on-line chemical analyzers has been combined with the latest electronics and production technologies to produce the 8240 Series of monitors from ABB.

Developed as fully continuous monitors, and offering wide dynamic ranging, the 8240 Series has been designed with greater simplicity than ever before. Based on colorimetric techniques they feature a carefully designed liquid handling section to reduce routine maintenance to a minimum. Utilizing microprocessor-based electronics, advanced features such as automatic calibration, continuous sample monitoring and programmable multistream switching ensure cost-effective ownership.

The size of the instrument has been reduced to a compact, ergonomically-designed, wall-mounted case containing all the components in the electronic and liquid handling sections.

## Applications

Typical applications for the Model 8242 phosphate monitor are in the monitoring and controlling of the phosphoric acid addition in drinking water for plumbo-solvency control; the monitoring and control of the dephosphatisation process in waste water treatment; monitoring phosphate in effluent discharges, rivers and lakes and controlling phosphate addition to boiler waters in steam raising plant, especially for power generation.

## Operation

### General

The Model 8242 is a robust, on-line wet chemistry monitor, designed for continuous stream monitoring of phosphate using the colorimetric analysis principle in applications such as:

- Waste and boiler water treatment
- Environmental monitoring
- Plumbo-solvency

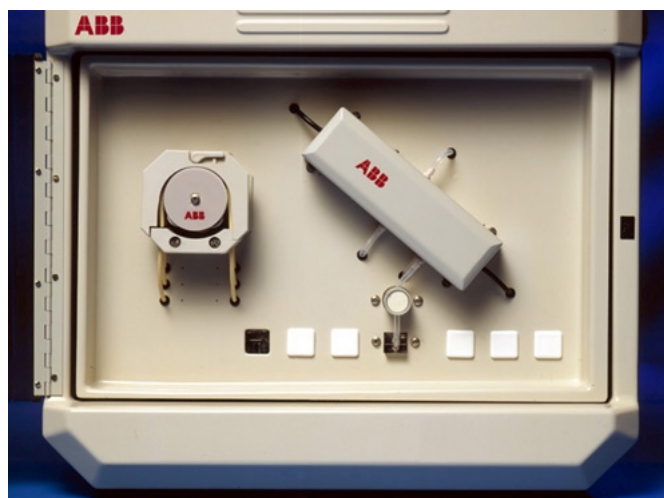

*Liquid Handling Section*

## Liquid Handling

The chemistry employed for phosphate measurements is that of the yellow molybdenum/vanadate reaction. Sample and reagents are drawn continuously into the instrument by means of a new precision engineered multichannel peristaltic pump, designed and constructed to ensure yearly intervals between tube or capstan maintenance requirements. Addition of the reagent is made sequentially, with full dynamic mixing to ensure a fully-reacted sample. A heated-block assembly optimizes thermal control of both the chemical reaction and optical measurement system. This obviates the requirement to temperature control the entire cabinet. A continuous reaction is ensured through the sample and reagents being pumped continuously. After reagent addition, the reacted sample is then pumped to the measurement cuvette. The new, servo controlled ratio optical measuring system gives full analyzer performance within the range 0 to 60ppm  $\text{PO}_4^{3-}$ .

## Electronics

The electronics are mounted on the monitor back plate with the display and key pad accessible from the front of the monitor.

Easy access and indication of all parameters is provided by a large backlit LCD graphics display module, which is easy to read in all light conditions. Under normal operating conditions the measured value is displayed with programming data being displayed during setting-up and also on demand. Units and range of measurement, alarm values and standard solution values are examples of the many programmable functions.

Keeping simplicity of operation at the forefront of design, the operation of the monitor is made straightforward through only five fingertip operated tactile membrane switches controlling the complete operation of the monitor.

On the single stream instrument there are two current outputs provided as standard with the option of a serial interface.

The microprocessor-based electronics package controls all instrument measurement and management functions. Two concentration alarms are provided with the addition of further relays to indicate remotely when the monitor is carrying out a calibration and when the monitor is 'Out of Service'. This latter relay, normally energized, is also used for a comprehensive range of diagnostic alarms, including mains and calibration failure.

An 'Out of Sample' sensor is fitted, providing a further relay output that can be used for remote indication.

## Multistream Facilities

A fully programmable multistream option is available on this instrument. This provides for up to six stream capability for the 8240 Series on-line analyzers. One current output and one relay contact is provided per stream, the latter being configured as a concentration or 'Out of Sample' alarm.

## Reagent Solution

The following single, combined reagent will maintain the monitor in operation for a period of approximately five weeks. The container and associated tubing are color coded for ease of identification.

Proceed as follows:

- a) Place approximately 4 liters high purity water in a plastic beaker and carefully add 2500 ml ( $\pm 10$  ml) analytical reagent grade concentrated nitric acid,  $\text{HNO}_3$  (1.42 s.g.). Stir the solution continuously during the addition and allow it to cool to room temperature before proceeding.

### For phosphate concentrations up to 10 mg l<sup>-1</sup> as P, 30 mg l<sup>-1</sup> as PO<sub>4</sub><sup>-3</sup>

- b1) Transfer 10.0 g ( $\pm 0.1$  g) analytical reagent grade ammonium metavanadate,  $\text{NH}_4\text{VO}_3$ , slowly to the nitric acid, stirring the solution continuously to dissolve the solid. (Use a little high purity water to help transfer the solid.)
- c1) Dissolve 200 g ( $\pm 1$  g) analytical reagent grade ammonium molybdate,  $(\text{NH}_4)_6\text{Mo}_7\text{O}_{24} \cdot 4\text{H}_2\text{O}$ , in approximately 2 liters of high purity water.

Go to step d).

OR

### For phosphate concentrations up to 20 mg l<sup>-1</sup> as P, 60 mg l<sup>-1</sup> as PO<sub>4</sub><sup>-3</sup>

- b2) Transfer 12.5 g ( $\pm 0.1$  g) analytical reagent grade ammonium metavanadate,  $\text{NH}_4\text{VO}_3$ , slowly to the nitric acid, stirring the solution continuously to dissolve the solid. (Use a little high purity water to help transfer the solid.)
- c2) Dissolve 250 g ( $\pm 1$  g) analytical reagent grade ammonium molybdate,  $(\text{NH}_4)_6\text{Mo}_7\text{O}_{24} \cdot 4\text{H}_2\text{O}$ , in approximately 2 liters of high purity water.

### For either concentration

- d) Carefully add the acid/metavanadate solution to the molybdate, stirring well to dissolve any precipitate and then make up to 10 liters with more high purity water to give a pale yellow solution.

This reagent has a shelf life of several months if kept in a tightly-stoppered plastic container.

## Standard Solutions

The following instructions are for the preparation of stock solutions of 1000 mg l<sup>-1</sup> either as P or PO<sub>4</sub><sup>-3</sup>.

- a) **Phosphate as P**  
Dissolve 4.393 g ( $\pm 0.001$  g) of analytical reagent grade potassium dihydrogen phosphate,  $\text{KH}_2\text{PO}_4$ , in approximately 500 ml of high purity water.

**Phosphate as PO<sub>4</sub><sup>-3</sup>**  
Dissolve 1.433 g ( $\pm 0.001$  g) of analytical reagent grade potassium dihydrogen phosphate,  $\text{KH}_2\text{PO}_4$ , in approximately 500 ml of high purity water.

- b) Transfer the appropriate solution to a one-liter volumetric flask and make to volume with more high purity water.

## Options

### Multistream Facility

As an option to the standard single stream unit, fully automatic stream switching facilities can be included for up to six streams. In this option an isolated current output is provided for each channel, also a concentration alarm. An additional feature provided on a multistream instrument is a loss of sample alarm for each channel with automatic switching to the next programmed stream, together with customer programmed stream sequencing. Visual indication of the stream being monitored is also available.

Additional options (please specify):

- a) Serial interface
- b) Multistream facility (indicate number of channels required)
- c) Consumable spares kit



Display and Key Pad

## General Specification

### Range

0 to 60mg<sup>-1</sup> as PO<sub>4</sub><sup>3-</sup>

0 to 20mg<sup>-1</sup> as P

### Accuracy

< ±0.05mg/l or < ±5% whichever is the greater

### Reproducibility

< ±0.05mg/l or < ±5% whichever is the greater

### Response time

90% step change in approximately 11 minutes

### Chemical drift

Dependent on reagents – typically less than ±5% of reading/month

### Control temperature range

20° to 45°C (68° to 113°F)

### Displays

Concentration and programming data by backlit l.c.d. graphics display module

### Status indication

Single stream:

Two LEDs illuminated when concentration alarms are exceeded

Single LED illuminated when calibration in progress

Single LED illuminated when monitor is 'Out of Service'

Single LED illuminated when HOLD switch operated

Multistream:

Six LEDs illuminated when concentration alarms are exceeded

Six LEDs (one per stream) when stream 'Out of sample'

Single LED illuminated when calibration in progress

Single LED illuminated when monitor is 'Out of Service'

Single LED illuminated when HOLD switch operated

### Current outputs

Single stream:

As standard two isolated current outputs 0 to 10, 0 to 20 or

4 to 20mA.

Range independently selectable over the full range of the monitor

Maximum voltage load 15V

Multistream:

As standard one isolated current output per stream 0 to 10,

0 to 20 or 4 to 20mA.

Range independently selectable over the full range of the monitor

Maximum voltage load 15V

### Computer interface

Optional second current output or RS485 serial interface

### Alarms

Single stream:

Two concentration relay outputs.

Can be configured as high or low concentration.

Remote 'Out of Sample' alarm

Remote calibration-mode indication.

Remote monitor 'Out of Service' alarm

Multistream:

Maximum of six (one per stream) relay outputs.

Can be configured as high or low concentration, or 'Out of sample' alarms

Remote calibration-mode indication.

Remote monitor 'Out of Service' alarm

### Concentration alarm adjustment

Programmable over monitor range

### Calibration

Frequency and time of day programmable, fully automatic, plus manual initiation on demand

### EMC

Conforms to EMC Directive (89/336/EEC)

Classifications BS EN 500 81-2

BS EN 500 82-2

Electrical safety BS EM 61010-1

## Installation Information

Install the monitor where the following conditions can be maintained:

### Sample flow

5 to 750ml.min<sup>-1</sup>

### Suspended solids

< 10mgl<sup>-1</sup>, < 60 microns

### Sample connections

Inlet 6mm, flexible hose connection

Outlet 9mm, flexible hose connection

### Ambient temperature

5° to 40°C (41° to 104°F).

### Sample temperature

5° to 55°C (41° to 131°F).

### Reagent Solutions

Consumption of the reagent is 10 liters per five weeks

### Calibration Solutions

A solution of one liter is required of concentration and formulation suitable for the particular range and application

### Enclosure dimensions

Height 740mm (29 in.)

Width 540mm (21 in.)

Depth 240mm (9.5 in.)

### Weight

25kg (55lb)

### Power supply

110 to 120V or 220 to 240V, 50/60Hz, 100VA

### Power supply tolerance

+6% to -20%

### Isolation voltage

Input, output and power supply 1.5kV

### Degree of protection

Electronics section – IP65

Liquid handling – Case IP31, Critical internal components IP65

## Maintenance

The instrument is designed for minimal maintenance requirement to maximize on-line availability.

Normal routine maintenance is limited to:

‘five-weekly’ – replenish reagents, clean flow system

‘twelve-monthly’ – replace tubing + pump capstans.

All consumable parts for one years normal operation, excluding reagents, are included in a consumable parts kit. This is available as an option and is required for the second and subsequent years operation.

Reagents are prepared from chemicals normally available from laboratory chemical suppliers. They can usually be prepared on-site without the necessity for specialized purchasing.

Outline Dimensions

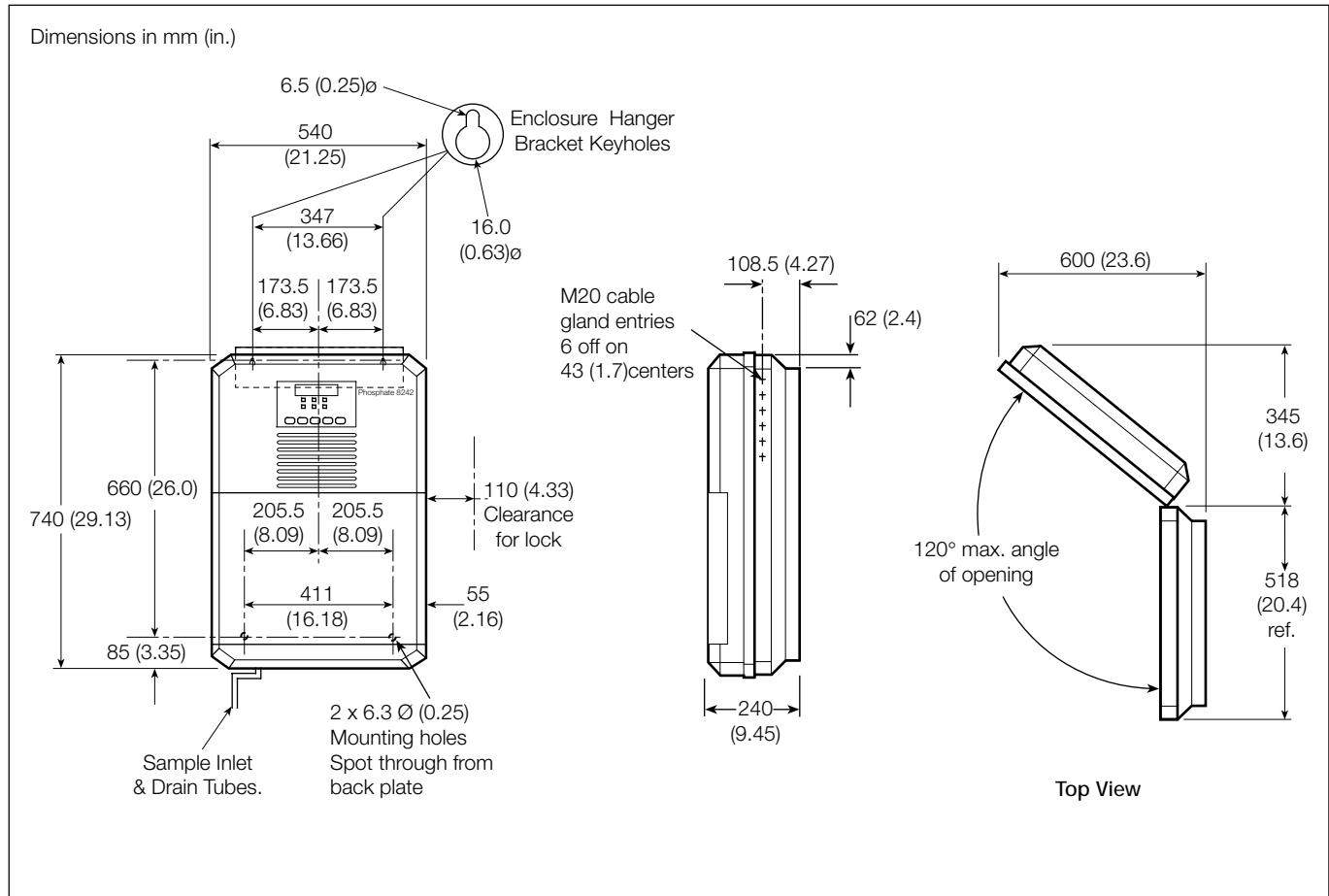

**Ordering Information**

Each monitor as supplied is set up to suit the most frequently encountered requirement. This can be very simply reconfigured if required at commissioning.

Phosphate Monitor	Model 8242/	XXX	X	X	X	X
<b>Multistream Option</b>						
Single stream		001				
2 Stream		002				
3 Stream		003				
4 Stream		004				
5 Stream		005				
6 Stream		006				
<b>Supply Voltage</b>						
115/230V 50Hz			0			
115/230V 60Hz			1			
115/230V 50Hz, less spares kit			4			
115/230V 60Hz, less spares kit			5			
<b>Construction</b>						
Standard				0		
Special				9		
<b>Output</b>						
Single isolated current output					0	
Modbus serial data interface					1	
<b>Language</b>						
English language manual						0
German language manual						1
French language manual						2
Spanish language manual						3
Special						9

---

ABB has Sales & Customer Support  
expertise in over 100 countries worldwide

[www.abb.com](http://www.abb.com)

The Company's policy is one of continuous product  
improvement and the right is reserved to modify the  
information contained herein without notice.

Printed in UK (11.06)

© ABB 2006



**ABB Limited**

Oldends Lane, Stonehouse  
Gloucestershire  
GL10 3TA  
UK  
Tel: +44 (0)1453 826661  
Fax: +44 (0)1453 829671

**ABB Inc.**

Analytical Instruments  
9716 S. Virginia St., Ste. E  
Reno, Nevada 89521  
USA  
Tel: +1 775 850 4800  
Fax: +1 775 850 4808