

Single and Dual Input Analyzers for Low-level Conductivity

AX410, AX411, AX416,
AX450 and AX455

■ Cost effective

- select one or two conductivity inputs or combine conductivity and pH/Redox (ORP) in one analyzer
- integral PID controller (AX410)

■ Reduced installation cost

- easy access terminations; reduced panel space

■ High functionality at minimum cost

- conductivity, resistivity, difference, ratio, % passage, % rejection and inferred pH calculations

■ Expanded monitoring and control

- add-on option board provides a total of five alarm relays and four current outputs
- service logbook providing historical data

■ Energy saving

- high visibility, backlit display with auto switch-off function

■ Reduced yearly maintenance costs

- 30V DC option negates the need for costly safety tests

■ Wide range of applicability

- water and waste water treatment
- power, pure water
- semiconductors
- chemicals
- pharmaceuticals
- pulp & paper



PROFI[®]
BUS

**More processing power,
higher performance**

ABB

The AX400 Series

The AX400 analyzers incorporate the latest technology to provide highly reliable, flexible, feature-packed devices that satisfy a diverse range of process monitoring and control applications. The complete range encompasses solutions for pH/Redox (ORP), conductivity and dissolved oxygen.

Models AX41x and AX45x enable continuous measurements of one or two low-level conductivity points with simultaneous local display and retransmission. The analyzers are used with ABB 2-electrode conductivity cells providing measurements with exceptional accuracy and performance.

Model AX45x analyzers are dedicated to United States Pharmacopœia <645>.

AX400 Series analyzers are available for either wall-/pipe- or panel-mounting and are rated to IP66 (NEMA4X).

High Functionality as Standard

All versions are supplied with two fully-isolated current outputs as standard, that can be assigned to the measured parameter, the sample temperature or any appropriate calculated variables.

Three programmable relay set points are available that can also be assigned as required.

Innovative features such as a power saving display and a diagnostic current output option all contribute to low cost of ownership.

Plug-and-Produce Expanded Control

An advanced function card provides an additional two current outputs and two further alarm relays that can be assigned to either measured values or sample temperature.

ABB Plug-and-Produce software automatically reconfigures the analyzer if an option board is added later. No user programming is necessary.

A real-time clock and logbook are also included, making the full-facility versions extremely powerful and versatile.

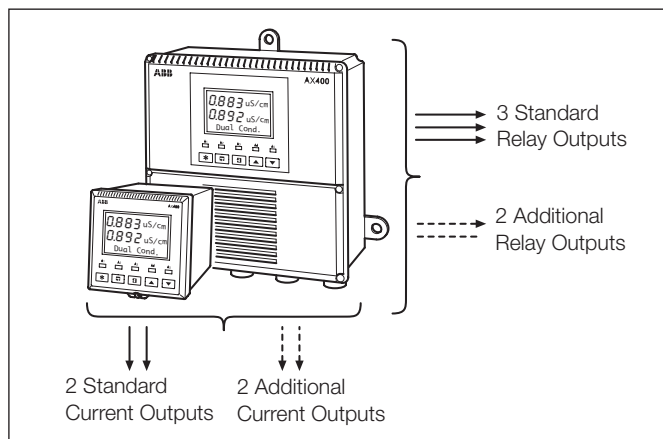

AX400 Outputs

Significantly Reduced Maintenance Costs

The AX400 Analyzers are supplied as standard for 85 to 265V AC operation. There are no inner switches to set.

They can also be provided for 24V AC or 12 to 30V DC supply and recognize automatically which of the two supplies is being used. 24V DC operation reduces maintenance costs significantly by negating the need for costly, yearly safety tests to ensure compliance with safety procedures.

Energy Saving Display

The backlit display has been designed to operate in all types of environments and shows both the measured parameter(s) and, on a separate 16-character display line, diagnostic and computed information.

On dual-input analyzers both measured parameters are displayed simultaneously.

For conservation of energy, the backlight can be set to switch off automatically after 60s of inactivity.



Backlight Can Be Set to Switch-off When Inactive

Easy Access Installation Terminals

Easy access to the terminations ensures rapid and cost-effective installation. The wall-/pipe-mount version has been designed to ensure that cable connection is simple and convenient. Ingress protection of the electronics section is retained even when the terminal compartment is opened.



AX400 Termination Chamber Makes Access Easy

Single and Dual Input Analyzers

Both single and dual-input analyzers provide accurate measurement of low-level conductivity and can be configured for ranges in $\mu\text{S cm}^{-1}$, $\mu\text{S m}^{-1}$, mS cm^{-1} and mS m^{-1} . Alternatively, the instrument can be set up for resistivity in $\text{M}\Omega\text{-cm}$, total dissolved solids and salinity.

In addition, the dual-input analyzer calculates, displays and transmits:

- Ratio of Cell 1/Cell 2
- Difference Cell 1 – Cell 2
- % Passage (Cell 1/Cell 2) x 100
- % Rejection (1 –[Cell 1/Cell 2]) x 100
- Inferred pH

These facilities are invaluable tools for demineralisation and reverse osmosis and a host of industrial processes.

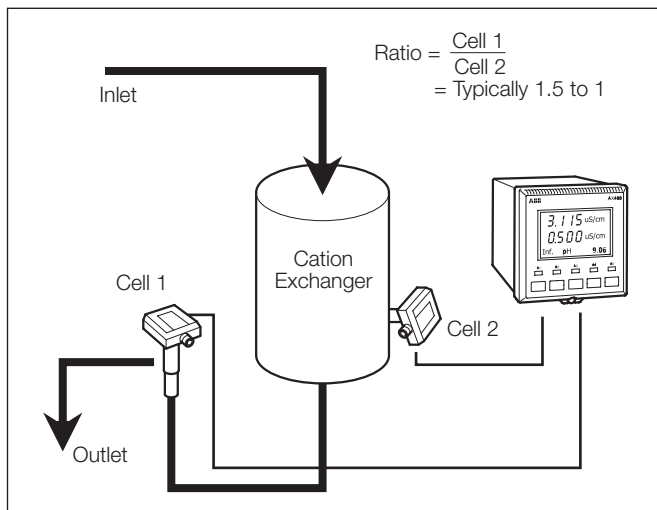

Cation Exchanger

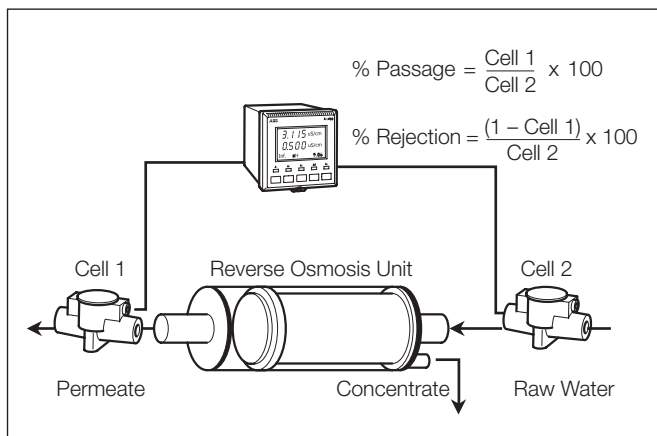

Reverse Osmosis

Cation Conductivity and Inferred pH Measurement

In low conductivity, ammoniated boiler waters, the AX411 analyzer can calculate an inferred pH measurement from the conductivity and a preset ammonia concentration. With this method, one AX411 provides cation conductivity, a direct output of pH, reduced cost and none of the maintenance associated with pH electrodes.

Self-monitoring of the validity of the pH measurement is achieved by checking that an after-cation conductivity value is sufficiently low. This measurement is provided by the second input of the AX411 analyzer. Alarm contacts can be configured for cation conductivity, invalid pH and exhausted resin.

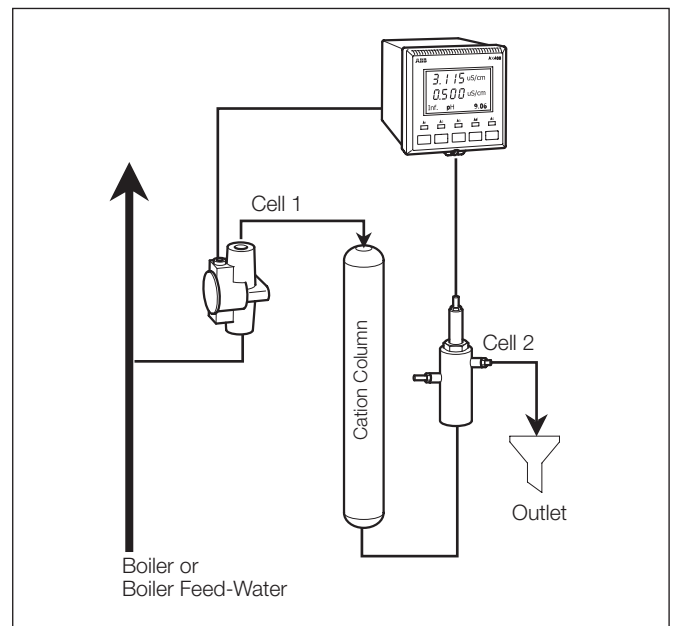

Inferred pH with Self-Diagnostic Alarm

AX410 Integral P, PI and PID Control

The single input AX410 analyzers incorporate three-term PID Control offering three modes of sophisticated control: analog, pulse length (time proportional) and pulse frequency. These are supplied as standard and can be operated in direct- or reverse-acting mode, depending upon the application.

Comprehensive Temperature Compensations

AX41x and AX45x conductivity analyzers provide true temperature compensation for all high-purity water applications:

Raw (uncompensated) conductivity

- USP<645> water for injection and purified water

NaCl

- General monitoring
- Mixed-bed exchanger
- Final polisher effluent
- Cation exchanger inlet
- Anion exchanger effluent
- Reverse osmosis

HCl

- Cation exchanger outlet
- Degassed cation conductivity
- Semiconductor rinse and reclaim water

NH₃

- Ammonia-treated make-up and boiler feed water
- Condenser sampling applications
- Hot well sampling applications
- Before-cation column applications
- Inferred pH in ammonia-dosed waters

Ultra Pure Water (UPW)

- Temperature effect of pure water only

Linear

- Manual entry of temperature coefficient

‘Trim’ Calibration

All ABB sensors are supplied pre-calibrated to exacting tolerances. This enables installation without the need for any further adjustment. The construction is robust and provides highly stable measurements over the sensor’s lifetime.

The single-point calibration facility enables local adjustment where on-site validation is required.

Combined Conductivity and pH

The AX416 version measures conductivity and pH with the same analyzer. The option board provides the capability to retransmit pH, conductivity and both sample temperatures. Five programmable alarms can be assigned to suit the needs of the application, enabling even the most demanding requirements to be met.



Simultaneous Conductivity and pH Measurement

Dual Input Measurement for Critical Duties

The AX400 enables two continuous measurements with simultaneous local display and retransmission. This capability provides an on-line validation of the process measurement.

Making two simultaneous measurements and configuring one of the set points as a difference alarm provides continuous on-line checking and early warning of an invalid measurement.

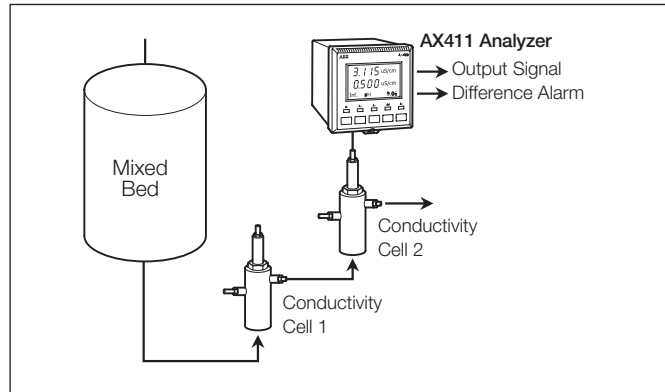

Dual-Input Comparator for Critical Measurements

AX41x Configurable Current Outputs

The analyzer’s current outputs are fully galvanically isolated and is configurable as 4 to 20mA, 0 to 20mA or 0 to 10mA. In addition, AX400 conductivity analyzers offer the user a choice in how the current output is configured:

- Linear
- 2-decade logarithmic
- 3-decade logarithmic
- Bi-linear with configurable break-point
- User-configurable between 0.1% and 100% of total span

Bi-linear and logarithmic ranges effectively provide a split output facility. General monitoring is covered with the lower range while still supplying excellent discrimination during high level excursions, such as during an alarm state.

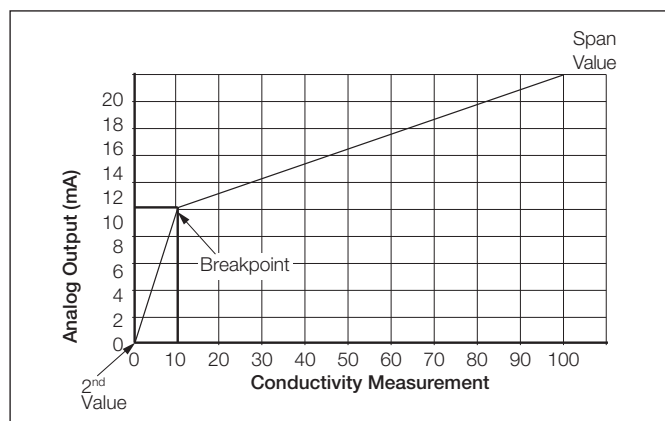

Bi-linear Output Maximizes Sensitivity Over the Critical Range

AX450 and AX455 USP <645> Conductivity

AX450 and AX455 analyzers have been developed specifically with the guidance of major leading pharmaceutical manufacturers to produce a system fully compliant to USP<645>.

The US Pharmacopœia has replaced the off-line qualitative test of water impurities, such as chloride, with a composite in-line Stage 1 Test based on conductivity.

Certification

To conform to USP<645> the accuracies of the instrument display and the sensor's cell constant are assured below specified limits. Each AX450 or AX455 analyzer and Model 2278 cell is supplied with a traceable test certificate.

Revalidation Facility

ABB provides a revalidation facility for the 2278 conductivity cell where the cell can be returned periodically for re-certification of the cell constant. This quick turnaround facility fulfills the stringent certification requirements of today's pharmaceutical industry.

Recording USP<645>

Two standard current outputs, or four (optional), enable both conductivity and temperature to be recorded externally as a permanent record of compliance.

Automatic Stage 1 Test

Maximum acceptable impurity levels are expressed by USP<645> as uncompensated conductivity at 5°C increments. The Stage 1 test of PW and WFI requires both parameters to be checked against the set limits.

The Stage 1 conductivity/temperature limits are stored within the AX45X analyzer and can be activated on a limit alarm contact. The alarm can be configured to initiate at a safe working distance from the Stage 1 limit. This enables assurance of operation to Stage 1 without manual intervention.

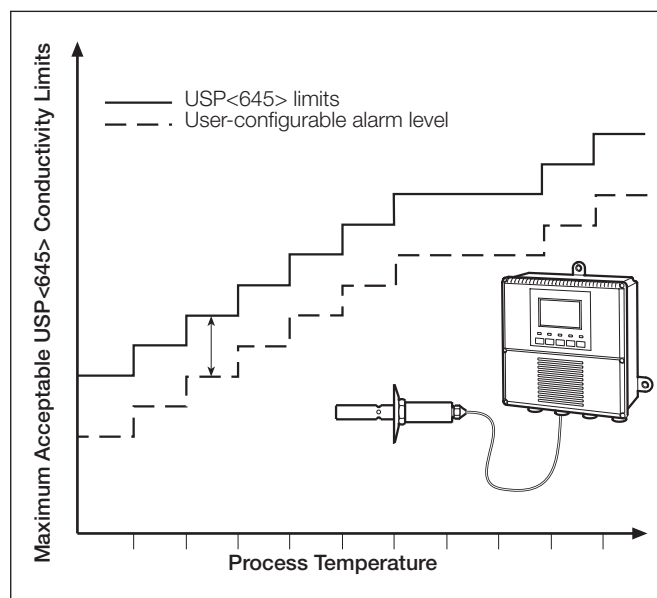

Automatic USP<645> Stage 1 Test

Total USP<645> Compliance

Specification	USP Requirement	Models AX450 & AX455
Conductivity Cell Constant	Verified to within ±2%	✓ Traceable verification to ±2% with certificate (normal accuracy ±1%). Re-verifiable
Resolution of Display	0.1µS cm ⁻¹	✓ 0.01µS cm ⁻¹
Instrument Accuracy	±1.0%; ±0.1µS cm ⁻¹	✓ Max. ±1.0% of FSD Min. 0.01µS cm ⁻¹ to max. 0.1µS cm ⁻¹ Traceable verification with certificate
Temperature Compensation	Uncompensated	✓ Uncompensated and compensated.
Measurement Range	0.2 to 4µS cm ⁻¹	✓ 0 to 1µS cm ⁻¹ to 0 to 10µS cm ⁻¹ , fully user configurable

Specification

Conductivity – AX41x and AX45x

Range

Programmable 0 to 0.5 to 0 to 10,000 μ S cm⁻¹
(with various cell constants)

Minimum span

10 x cell constant

Maximum span

10,000 x cell constant

Units of measure

μ S cm⁻¹, μ S m⁻¹, mS cm⁻¹, mS m⁻¹, M Ω -cm and TDS

Accuracy

Better than $\pm 0.01\%$ of span (0 to 100 μ S cm⁻¹)

Better than $\pm 1\%$ of reading (10,000 μ S cm⁻¹)

Operating temperature range

-10 to 200°C (14 to 392°F)

Temperature compensation

-10 to 200°C (14 to 392°F)

Temperature coefficient

Programmable 0 to 5%/°C and fixed temperature compensation curves (programmable) for acids, neutral salts and ammonia

Temperature sensor

Programmable Pt100 or Pt1000

Reference Temperature

25°C (77°F)

Calculated variables – AX411

Ratio	0 to 19,999
Difference	0 to 10,000 μ S cm ⁻¹
Percent passage or rejection	0 to 100.0%
Total dissolved solids	0 to 8,000 ppm
Inferred pH	7.0 to 10.0pH (NH ₃ -dosed systems) 7.0 to 11.0pH (NaOH-dosed systems)*

* pH calculation according to the appendix in the VGB directive 450L, 1988.

pH /Redox (ORP) – AX416

Inputs

pH or mV input and solution earth

Temperature sensor Pt100, Pt1000 or Balco 3k

Enables connection to glass or enamel pH and reference sensors and Redox (ORP) sensors

Input resistance

Glass >1 x 10¹³ Ω

Reference 1 x 10¹³ Ω

Range

-2 to 16pH or -1200 to +1200mV

Minimum span

Any 2pH span or 100mV

Resolution

0.01pH

Accuracy

0.01pH

Temperature compensation modes

Automatic or manual Nernstian compensation

Range -10 to 200°C (14 to 392°F)

Process solution compensation with configurable coefficient

Range -10 to 200°C (14 to 392°F)

adjustable -0.05 to +0.02%/°C (-0.02 to +0.009%/°F)

Temperature sensor

Programmable Pt100, Pt1000 or Balco 3k Ω

Calibration Ranges

Check value (zero point)

0 to 14pH

Slope

Between 40 and 105% (low limit user configurable)

Electrode Calibration Modes

Calibration with auto-stability checking

Automatic 1 or 2 point calibration selectable from:

ABB

DIN

Merck

NIST

US Tech

2 x User-defined buffer tables for manual entry,
2-point calibration or one-point process calibration

Display

Type

Dual 5-digit, 7-segment backlit LCD

Information

16-character, single line dot-matrix

Energy-saving function

Backlit LCD configurable as ON or Auto-Off after 60s

Logbook*

Electronic record of major process events and calibration data

Real-time clock*

Records time for logbook and auto-manual functions

*Available if option board is fitted.

Relay Outputs – On/Off

Number of relays

Three supplied as standard or five with option board fitted

Number of set points

Three supplied as standard or five with option board fitted

Set point adjustment

Configurable as normal or failsafe high/low or diagnostic alert

Hysteresis of reading

Programmable 0 to 5% in 0.1% increments

Delay

Programmable 0 to 60s in 1s intervals

Relay contacts

Single-pole changeover

Rating 5A, 115/230V AC, 5A DC

Insulation

2kV RMS contacts to earth/ground

Analog Outputs

Number of current outputs (fully isolated)

Two supplied as standard or four with option board fitted

Output range

0 to 10mA, 0 to 20mA or 4 to 20mA

Analog output programmable to any value between 0 and 22mA to indicate system failure

Accuracy

$\pm 0.25\%$ FSD, $\pm 0.5\%$ of reading (whichever is the greater)

Resolution

0.1% at 10mA 0.05% at 20mA

Maximum load resistance

750 Ω at 20mA

Configuration

Can be assigned to either measured variable or either sample temperature

Digital Communications

Communications

Profibus DP (with option board fitted)

Control Function – AX410 Only

Controller Type

P, PI, PID (configurable)

Control Outputs

Analog

Current output control (0 to 100%)

Time proportioning cycle time

1.0 to 300.0s, programmable in increments of 0.1s

Pulse frequency

1 to 120 pulses per minute, programmable in increments of 1 pulse per minute

Controller action

Direct or reverse

Proportional band

0.1 to 999.9%, programmable in increments of 0.1%

Integral action time (Integral reset)

1 to 7200s, programmable in increments of 1s (0 = Off)

Derivative

0.1 to 999.9s in increments of 0.1s – only available for single set point control

Auto/Manual

User-programmable

...Specification

Access to Functions

Direct keypad access

Measurement, maintenance, configuration, diagnostics or service functions

Performed without external equipment or internal jumpers

Sensor Cleaning Function – AX416 Only

Configurable cleaning action relay contact

Continuous

Pulse in 1s on and off times

Frequency

5 minutes to 24 hours, programmable in 15 minute increments up to 1 hour then in 1 hour increments for 1 to 24 hours

Duration

15s to 10 minutes, programmable in 15s increments up to 1 minute then in 1 minute increments up to 10 minutes

Recovery period

30s to 5 minutes, programmable in 30s increments

Mechanical Data

Wall-/Pipe-mount versions

IP66/NEMA4X

Dimensions 192mm high x 230mm wide x 94mm deep
(7.56 in. high x 9.06 in. wide x 3.7 in. deep)

Weight 1kg (2.2 lb)

Panel-mount versions

IP66/NEMA4X (front only)

Dimensions 96mm x 96mm x 162mm deep
(3.78 in. x 3.78 in. x 6.38 in. deep)

Weight 0.6kg (1.32 lb)

Cable Entry Types

Standard 5 or 7 x M20 cable glands

North American 7 x knockouts suitable for 1/2 in. Hubble gland

Power Supply

Voltage requirements

85 to 265V AC 50/60 Hz

24V AC or 12 to 30V DC (optional)

Power consumption

<10VA

Insulation

Mains to earth (line to ground) 2kV RMS

Environmental Data

Operating temperature limits

-20 to 65°C (-4 to 149°F)

Storage temperature limits

-25 to 75°C (-13 to 167°F)

Operating humidity limits

Up to 95%RH non condensing

EMC

Emissions and immunity

Meets requirements of:

EN61326 (for an industrial environment)

EN50081-2

EN50082-2

Hazardous area approvals

CENELEC ATEX IIG EEx n IIC T4 Pending

FM non-incendive Class I Div. 2 Groups A to D Pending

CSA non-incendive Class I Div. 2 Groups A to D Pending

Safety

General safety

EN61010-1

Overvoltage Class II on inputs and outputs

Pollution category 2

Languages

Languages configurable:

English

French

German

Italian

Spanish

Overall Dimensions

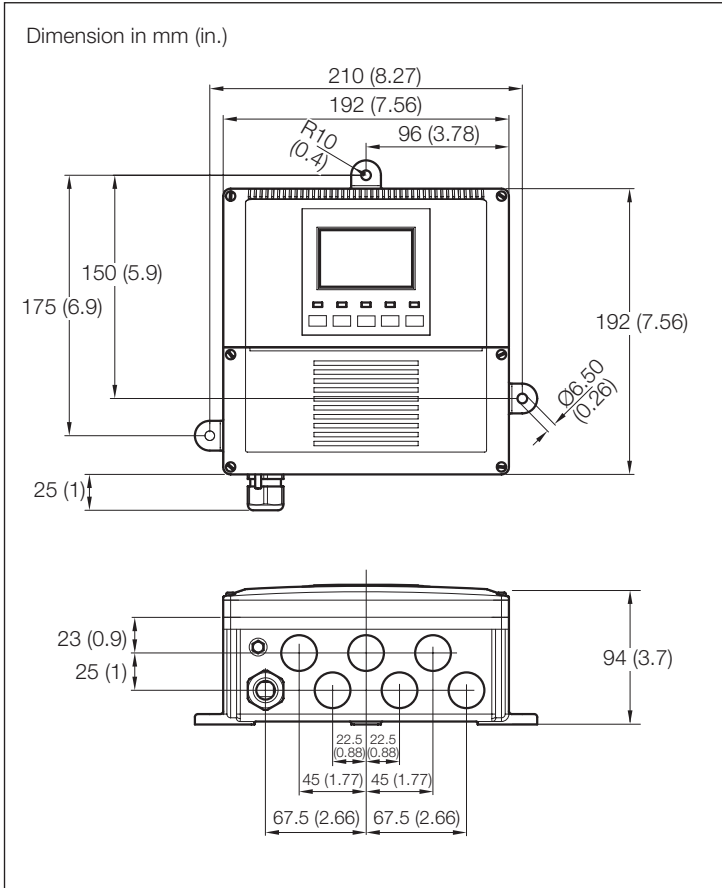

Wall-/Pipe-mount Version

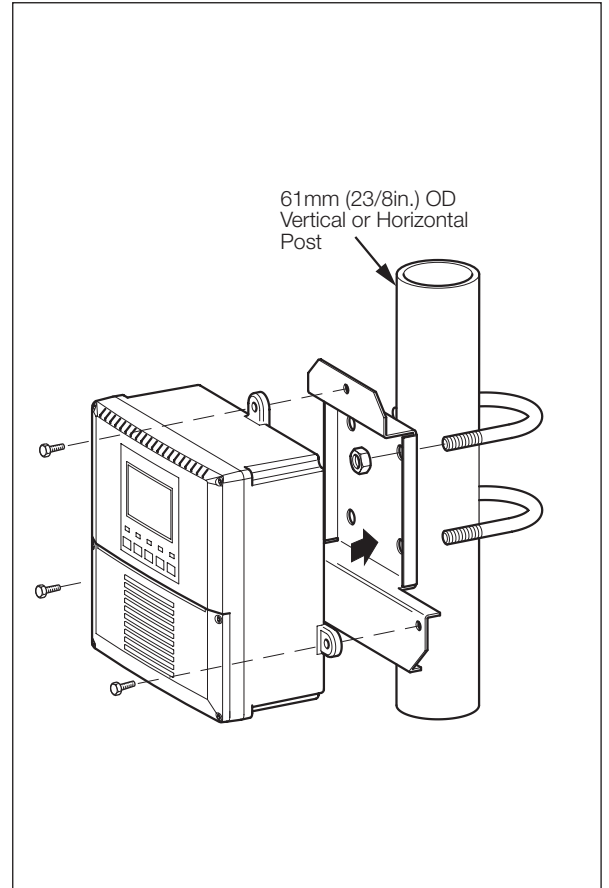

Pipe-mount Detail

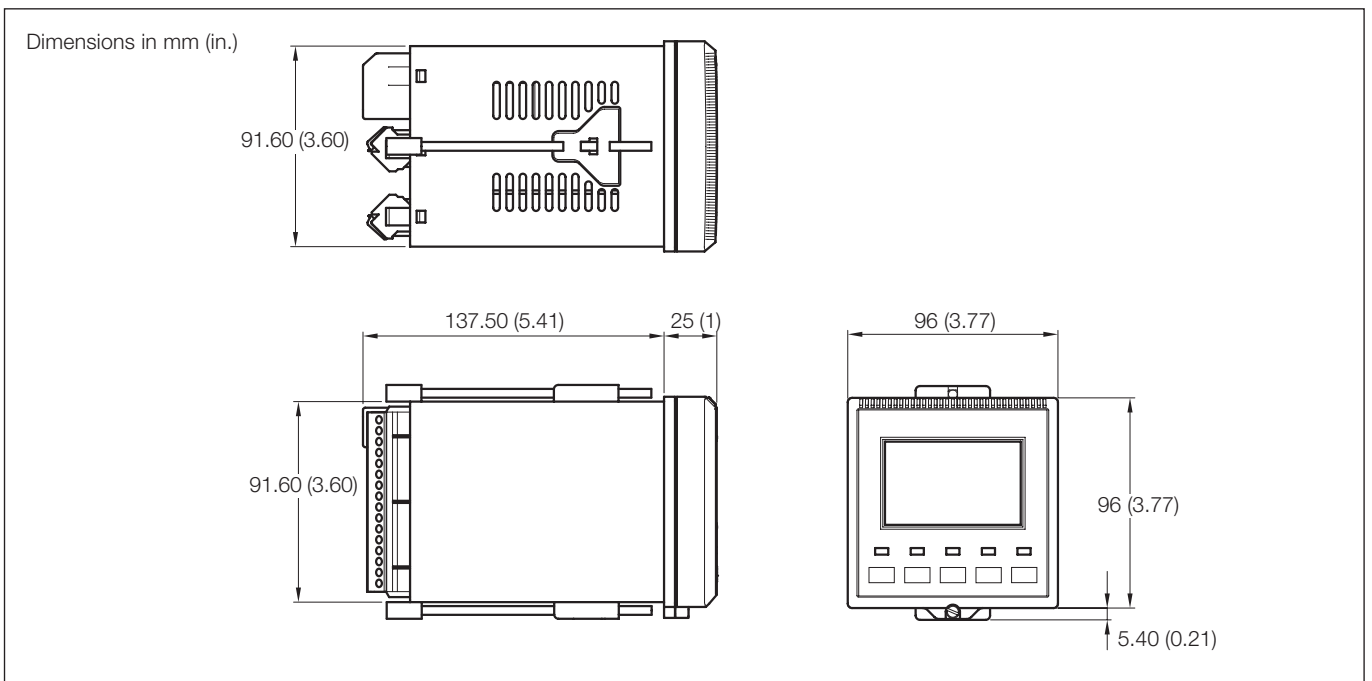

Panel-mount Version

Electrical Connections

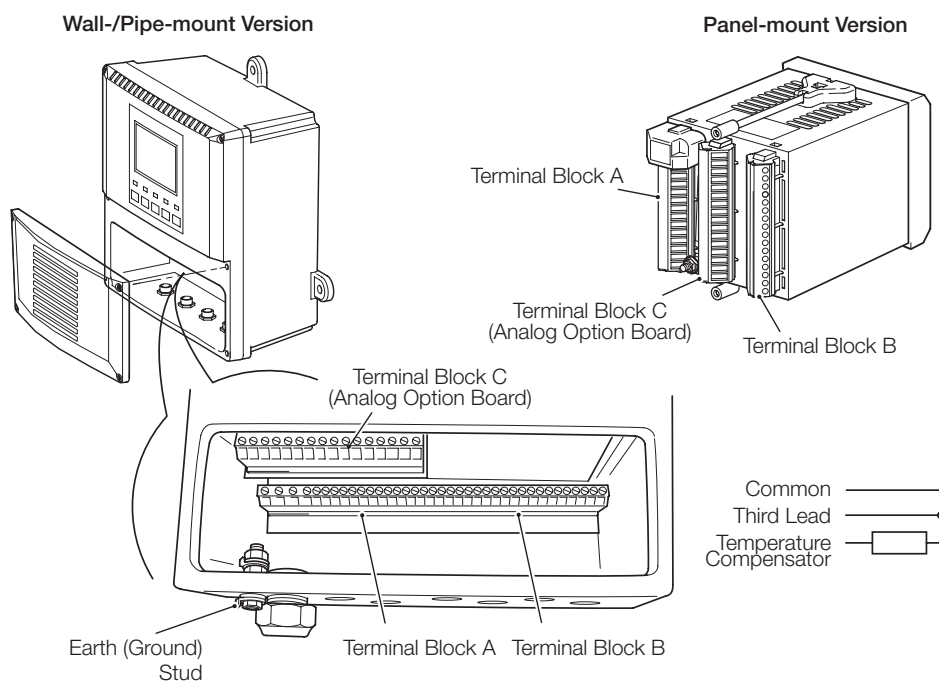

Terminal block A

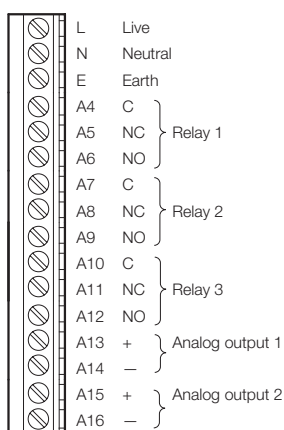

Terminal Block C (Analog Option Board)

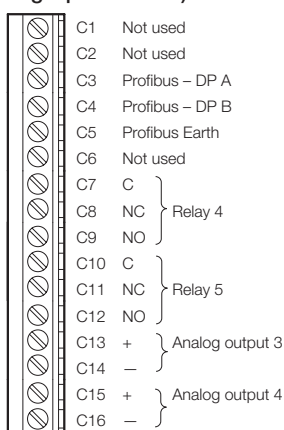

Terminal Block B (see table below)

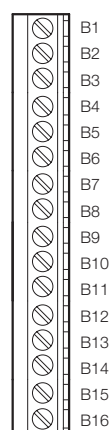

Terminal Block B		Conductivity	pH/Redox (ORP) without Solution Earth†	pH/Redox (ORP) with Solution Earth†
Sensor B	Sensor A			
1	9	Temperature Compensator common Link 1 & 2 / 9 & 10**	Temperature Compensator common* Link 1 & 2 / 9 & 10**	Temperature Compensator common*
2	10	Temperature Compensator third lead	Temperature Compensator third lead*	Temperature Compensator third lead*
3	11	Temperature Compensator Screen	Temperature Compensator*	Temperature Compensator*
4	12	Cell (Cell Electrode)	Not applicable	Reference Electrode
5	13	Cell (Earth Electrode)	Not used	Not used
6	14	Cell (Earth Electrode)	Reference Electrode	Solution Earth†
7	15	Not used	Screen*	Screen*
8	16	Not used	Glass/Metal Electrode	Glass/Metal Electrode

*If fitted.

**When a 2-wire Pt100, Pt1000 or BALCO temperature compensator is fitted.

†Solution Earth also referred to as Ground Rod.

Ordering Information

Single and Dual Input Analyzers for Conductivity and pH Models AX410, AX411 & AX416	AX4	X	X	X	X	X	0	X
First Process Variable (PV1)								
Conductivity 0 to 10,000µS cm ⁻¹ for 2-electrode sensors		1						
Conductivity 0 to 1,999mS cm ⁻¹ for 4-electrode sensors		3						
Conductivity USP<645> for 2-electrode sensors		5						
pH/Redox (ORP)		6						
Dissolved Oxygen		8						
Second Process Variable (PV2)*								
No second process variable – select for PID control of PV1							0	
Conductivity 0 to 10,000µS cm ⁻¹ for 2-electrode sensors		1						
Conductivity 0 to 1,999mS cm ⁻¹ for 4-electrode sensors**		3						
Conductivity USP<645> for 2-electrode sensors		5						
pH/Redox (ORP)		6						
Dissolved Oxygen		8						
Enclosure Types								
Wall-mount IP66/NEMA 4X, General								
Wall-mount – cable glands fitted							1	
Pipe-mount							2	
Wall-mount NEMA 4X/IP66, North American								
Wall-mount							6	
Pipe-mount							7	
Panel-mount, Universal								
Panel-mount**							5	
Advanced Functions & Communications								
Basic (2 current outputs + 3 relays)							0	
Advanced (4 current outputs + 5 relays + logbook)							1	
Profibus DP, basic (2 current outputs + 3 relays)**							2	
Profibus DP, advanced (4 current outputs + 5 relays + logbook)**							3	
Power Supply								
85 to 265V AC 45 to 65Hz							0	
24V AC/12 to 30V DC (auto-selection)							1	
85 to 265V AC 45 to 65Hz (tropicalized)†							2	
24V AC/12 to 30V DC (auto-selection, tropicalized)†							3	
Reserved								0
Manual								
English								1
French								2
Italian								3
German								4
Spanish								5

* When ordering units with a second process variable (PV2) the code digit for PV2 in the order code number must be equal to, or greater than, the code digit for PV1, e.g. AX416 permissible, AX461 not permissible.

** Profibus DP not available in panel-mount housing when 0 to 1,999mS/cm is selected as Second Process Variable (PV2).

† Check factory for availability of tropicalization.

ABB has Sales & Customer Support expertise in over 100 countries worldwide

www.abb.com

The Company's policy is one of continuous product improvement and the right is reserved to modify the information contained herein without notice.

Printed in UK (08.06)

© ABB 2006



ABB Limited

Oldends Lane, Stonehouse
Gloucestershire
GL10 3TA
UK
Tel: +44 (0)1453 826661
Fax: +44 (0)1453 829671

ABB Inc.

Analytical Instruments
9716 S. Virginia St. Ste., E
Reno, Nevada 89521
USA
Tel: +1 775 850 4800
Fax: +1 775 850 4808