

Electronic Water Meter for Water Revenue Service

AquaMaster R



■ **Designed specifically to meet the requirements of the water metering revenue market**

- widest flow range, highest accuracy
- measures both night and peak day flows

■ **Tariff function**

- programmable for daily, weekly & seasonal rates

■ **Encoder reading**

- remote reading using standard inductive pad or via radio link automatic meter reading system

■ **Battery operation**

- 3-year life
- no external power supply required, facilitates installation in remote locations

■ **'Fit and Flow™'**

- foolproof installation; no on-site setup

■ **Flow profile conditioning sensor**

- tolerant of poor upstream and downstream conditions

■ **Buriable sensor and submersible Transmitter**

- including flooded pits
- eliminates chamber and ensures fast, low-cost installation



AquaMaster R
– new technology water meter for
Bulk Revenue metering



The Next Generation

Commercial Water Flow Meter

AquaMaster R, available in sizes 50 to 300 mm (2 in. to 12 in.), is the total solution for flow measurement in the water industry. Outstanding performance, innovative features and user benefits, coupled with low cost of ownership ensures that AquaMaster R is the first choice for Bulk Revenue applications.

AquaMaster R has been designed specifically for the water industry in response to its stringent demands for enhanced metering capability; enabling ever more efficient and cost effective operation and compliance with increasing legislative requirements.

Based on ABB-proven technology, AquaMaster R is supported by the expertise of ABB – the world's leading flowmeter manufacturer with many pioneering advances in water flow metering over the last decade, e.g. AquaMag™, MagMaster™, AquaProbe™, CalMaster™ etc. ABB operates national and internationally accredited flow calibration facilities in the UK, Germany, USA, Australia and India. We also offer comprehensive, locally-based before- and after-sales support and service.

In addition to high measurement performance, the AquaMaster R offers reading of totalizers via the industry-standard inductive pad reader or via radio links. This feature enables easy access to billing information without the need to physically read the meter.

No External Power Required for Remote Locations

- No external power supply (2 internal batteries)
- 3-year battery life
- Site-replaceable batteries
- Unique battery management system gives a battery replacement window in excess of 1 year, with no flat-battery interruption to measurement.

AquaMaster™ is the ideal solution for locations where there is no external power. Two user-replaceable internal batteries provide a 3-year battery life, thus eliminating the high cost of providing a mains supply to the meter.

AquaMaster's extended battery life is achieved through new technology design.



New Performance Standards for Flow Measurement

Widest flow range, optimum accuracy and long term stable calibration mean that AquaMaster™ sets new performance standards in the water industry.

This unique low flow rate capability enables previously unrecordable night flow rates to be metered in bulk revenue applications.

The clear bore of the AquaMaster R eliminates the possibility of damage by particulate matter and the absence of moving and wearing components ensures that this exceptional level of performance is maintained long term.

The unique design of the AquaMaster sensor conditions the flow profile in the measuring section so that distortions in the flow profile, either upstream or downstream, are flattened; resulting in excellent in situ meter performance, even with very bad hydraulic installation conditions. Tests have shown that with a gate valve bolted directly on the upstream flange of the meter, performance is still within ISO4064 Class B, even with the gate virtually shut.

Transmitter

- Comprehensive display
- Submersible for use in flooded chambers rated IP68 (NEMA 6)
- Resettable or secure totals
- 8mm high displays for Totals (exceeds ISO4064 requirement)
- Total security:
 - 2 user security levels
 - Anti-tamper seals and switch
- 2 outputs (pulses and alarm)

The AquaMaster Transmitter provides the most comprehensive range of flow data and information currently available to the water industry. If all the data is not required, the unit can be configured so that only the required values are displayed, thus ensuring simple reading with no superfluous data. Likewise, the display is available for top or side viewing, depending on the location of the meter, for easy reading in all locations.

Standard Tariff Setting

AquaMaster incorporates a multiple tariff feature where the accumulated flow volume is routed to one of two 8-digit signed tariffs; tariff A and tariff B, depending on time and date. It is fully programmable by the user for time of day, day of week or date during the year. These user-defined times/dates can be combined in a variety of modes to produce the following tariff regimes:

Weekly Cycle Defined

Mode	Tariff A	Tariff B
1	Day time during weekend	Night time at weekend + day and night during week
2	Day time during week	Night time during week + day and night during weekend
3	All day times	All night times
4	Night time during weekend	Day time during weekend + day and night during week
5	Day and night during weekend	Day and night during week
6	Day time during weekend + night time during weekend	Night time during week + day time during weekend
7	All day times + night time during weekend	Night time during week

Yearly Cycle Defined

Mode	Tariff A	Tariff B
1	Day time during summer	Night time during summer + day and night during winter
2	Day time during winter	Night time during winter + day and night during summer
3	All day times	All night times
4	Night time during summer	Day time during summer + day and night during winter
5	Day and night during summer	Day and night during winter
6	Day time during winter + night time during summer	Night time during winter + day time during summer
7	All day times + night time during summer	Night time during winter

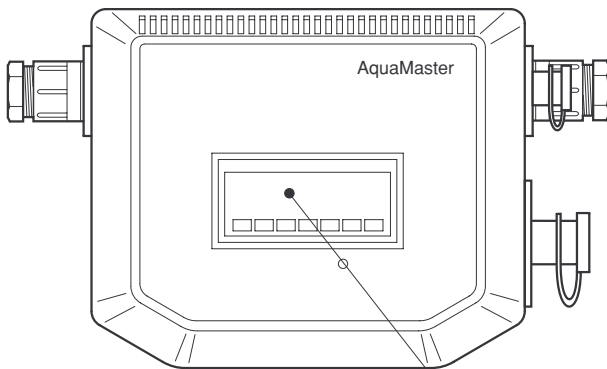

9-Digit LCD Display

- Cyclic display*
- 8mm High
 - Forward total
 - Date
 - Tariff Total

Tariff Indicator



Choice of Flow Units

to match user requirements

5-Digit LCD Display

- Cyclic display*
- Flow rate
 - Time
 - Velocity

Status Indicators

- Battery A low
- Fault
- Empty pipe
- Battery B low

* Can be programmed to display required values only

Easy, Low Cost Installation

No matter what the location or installation requirements, AquaMaster R provides a cost-effective solution.

Both the sensor and the Transmitter are fully submersible, enabling installation in flooded chambers and meeting the requirements of IP68 (NEMA 6).

In addition, the sensor is buriable, thus eliminating the need for a chamber. Installation merely involves excavating to the pipeline, fitting the sensor and back filling the hole; ensuring very fast, low-cost installation. The associated Transmitter is then located in the most convenient position for the user.

The elimination of bypasses and ancillary items such as strainers, enables the installation cost to be kept to an absolute minimum.

These factors, together with the innovative 'Fit and Flow' system, ensure foolproof installation with total user confidence.

'Fit and Flow'

- No need to match sensor and Transmitter
- Fast, reliable installation
- Foolproof, no errors
- Sensor stores all calibration factors, site settings, serial numbers, etc.
- Volume totalizer and tariff values backed-up in sensor for total security
- Multiple, programmable password levels stored for measurement security
- Tamper resistant



Underground Installation of AquaMaster R

Specification

Flow Requirements per CEN pr 14154

Size		Q ₄	Q ₃	Q ₂	Q ₁	R
mm	in.	m ³ /h (Ugal/min)	m ³ /h(Ugal/min)	m ³ /h(Ugal/min)	m ³ /h(Ugal/min)	
50	2	50 (220)	40 (176)	1 (4.4)	0.4 (1.8)	100
65	2½	79 (347)	63 (277)	1.6 (7)	0.63 (2.8)	100
80	3	125 (550)	100 (440)	2.5 (11)	1 (4.4)	100
100	4	200 (881)	160 (704)	4 (18)	1.6 (7.0)	100
150	6	500 (2200)	400 (1760)	10 (44)	4 (18)	100
200	8	788 (3470)	630 (2770)	16 (69)	6.3 (28)	100
250	10	1250 (5500)	1000 (4400)	25 (110)	10 (44)	100
300	12	2000 (8810)	1600 (7040)	40 (176)	16 (70)	100

Flow Requirements per ISO 4064 Class B

Size		Q _{max.}	N	Q _t	Q _{min.}
mm	in.	m ³ /h (Ugal/min)	m ³ /h (Ugal/min)	m ³ /h (Ugal/min)	m ³ /h (Ugal/min)
50	2	30 (132)	15 (66)	3 (13.2)	0.45 (2.0)
65	2½	50 (220)	25 (110)	5 (22)	0.75 (3.3)
80	3	80 (358)	40 (176)	8 (35)	1.2 (5.3)
100	4	120 (528)	60 (264)	12 (53)	1.8 (7.9)
150	6	300 (1320)	150 (660)	30 (132)	4.5 (20)
200	8	500 (2200)	250 (1100)	50 (220)	7.5 (33)
250	10	800 (3520)	400 (1760)	80 (350)	12 (53)
300	12	1200 (5280)	600 (2640)	120 (530)	18 (79)

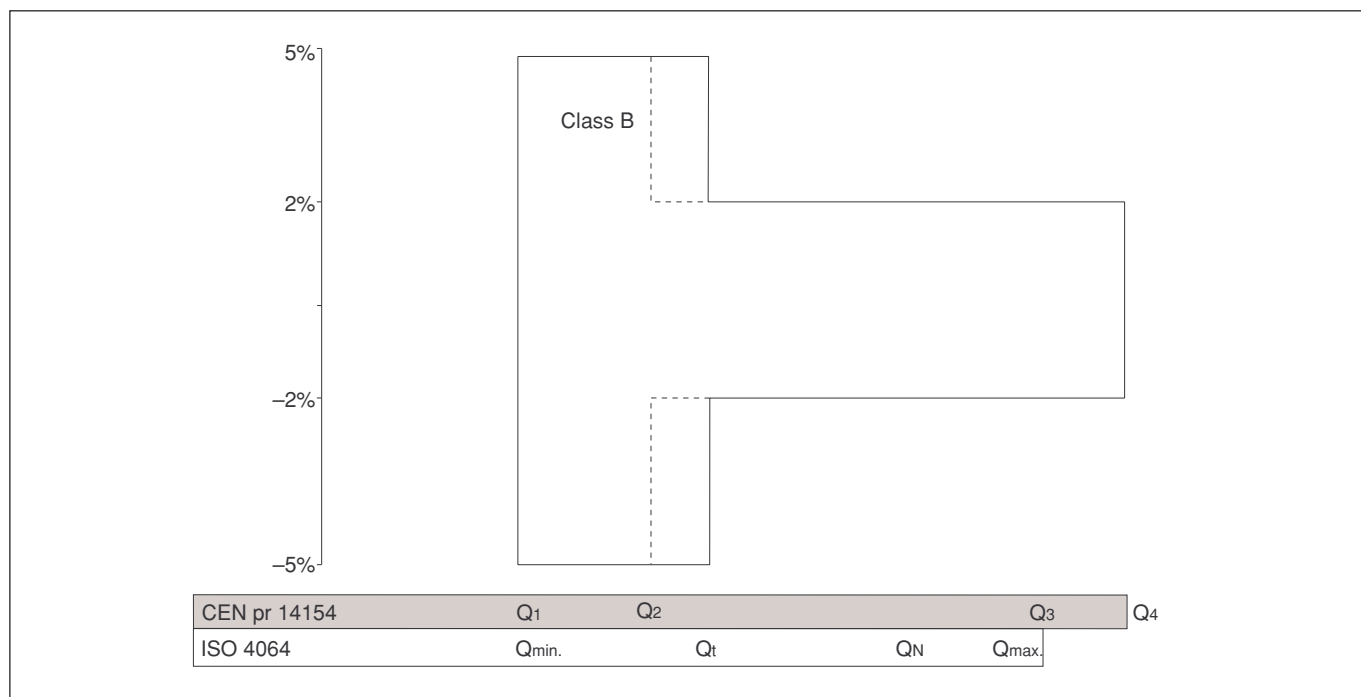

Performance Specification with CEN pr 14154 and ISO 4064

...Specification

Wetted Materials

Lining

Suitable for potable water (UKWFBS listed)
Electrodes – stainless steel 316L

Pressure limitations

As flange rating

Pressure equipment directive

This product is applicable in networks for the supply, distribution and discharge of water and associated equipment and is therefore exempt.

Conductivity

>50 μ S/cm

End Connections

50 to 300mm (1.5 to 12 in.) flanged

BS4504/ISO 7005 – PN16, PN10
ANSI B16.5 1.5 Class 150
AS 2129 Tables C, D and E
AS 4087/14, AS4087/16
JIS to BS2210, 5k, 10k and 30k
BS10 Tables D and E

Transmitter

Integral with sensor
or
Remote up to 200m (650 ft)

Housing

IP68 (NEMA 6P) aluminium alloy with glass window

Cable entries

20/16mm plastic glands
20mm armored
or
accepts 1/2 in. NPT threaded
or
military-style plug & socket

Sensor cable

ABB cable supplied as standard
SWA cable available on application

Power supply

Battery life @ 0 to 50°C (32 to 122°F)
1 battery – typically 1.2 years
2 batteries – typically 3 years

Battery type

3.6V Lithium

Temperature Ranges

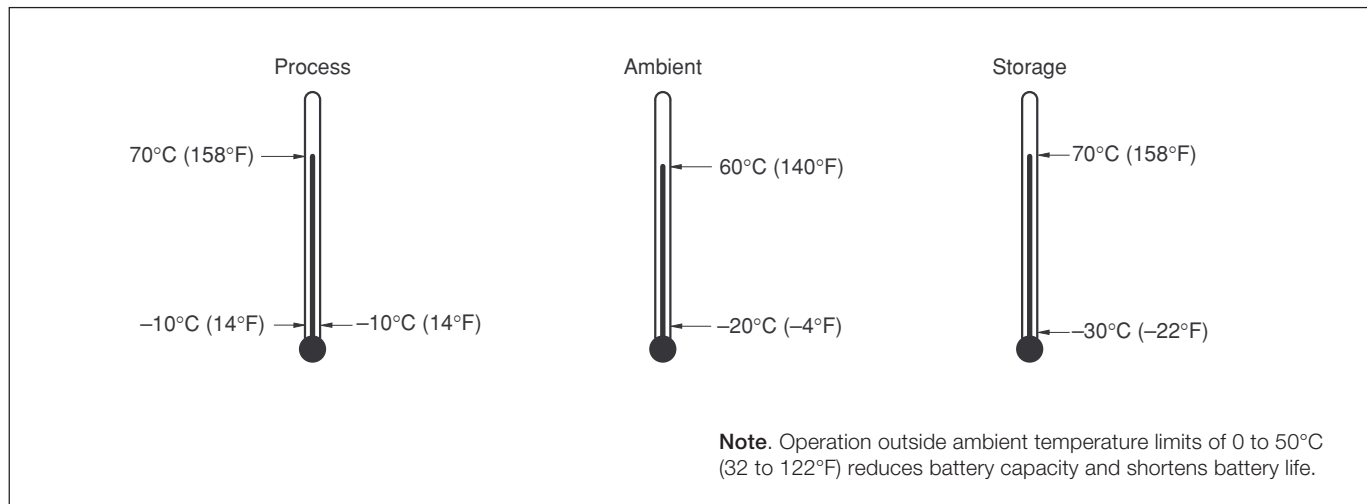

...Transmitter

Pulse outputs

Three bi-directional solid state switches with common isolation $\pm 35V$ DC 50mA.

- Output 1 Forward only pulses
- Output 2 Not used
- Output 3 Alarm indicates any problems with the measurement or unit power
- Pulse output 50Hz maximum, 50% nominal duty cycle

Serial Data Communications

- Local Port RS232 compatible via ABB lead (Option)
- Remote Port (option) RS232 with RI, RTS and CTS handshaking

Encoder Interface

Function

Remote reading of totalizers and serial no.

Protocol

ABB Encoder

Connections

- 2-wire for inductive pads (max. cable length 80m [260 ft])
- 3-wire for AMR

Compatible readers

- Severn Trent Services Smart Reader
- ABB SR100 and SR50
- Logicon Versaprobe
- Itron ERT

Compatible inductive pads

- Starpad
- ABB

Response time (programmable)

Minimum

15s (battery-powered)

Languages

- English
- French
- German
- Spanish
- Italian
- Dutch

Languages can be changed via Windows download program (contact ABB)

Mounting

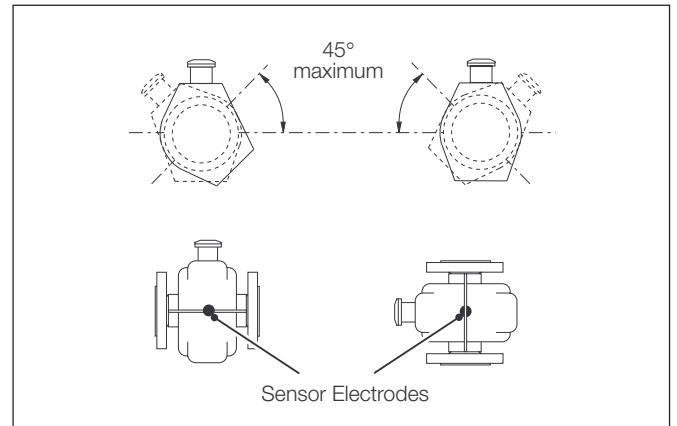

Pipe Conditions

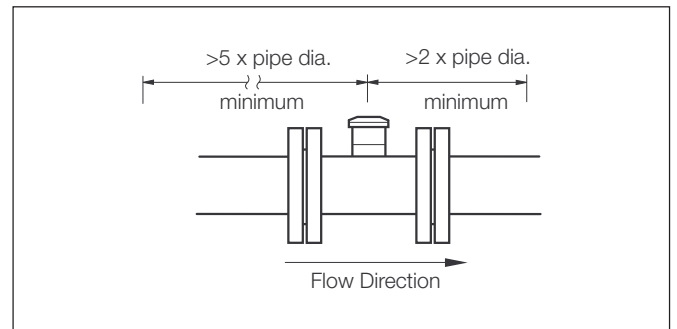

Pressure Loss

Flow Rate	Pressure Loss
	bar (psi)
Q ₃ (CEN)	<0.63 (9.1)
ISO 4064 Q _{max.}	<0.3 (4.4)
ISO 4064 Q _n	<0.075 (1.1)
ISO 4064 Q ⁿ / ₂	<0.019 (0.3)

Overall Dimensions

50 to 300mm (1½ to 12 in.) – Flanged

Meter Size		Dimensions mm (in.)		Approx. Weight	
mm	in.	A	B	kg	lb
50	2	176 (7)	200 (7.9)	12	27
65	2½	219 (8.6)	200 (7.9)	13	29
80	3	219 (8.6)	200 (7.9)	18	40
100	4	230.5 (9.8)	250 (9.8)	15	33
150	6	281 (11.8)	300 (11.8)	31	68
200	8	402 (15.8)	350 (13.8)	48	106
250	10	440 (17.3)	450 (17.7)	75	165
300	12	480 (18.9)	500 (19.7)	112	247

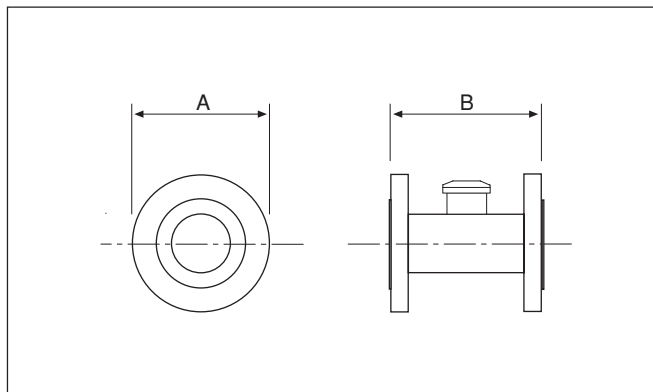

Default Settings

Configuration Parameter	Default European	Default American
Pulse Factor	1	1
Pulse Units	m ³	Ugal
Totalizer Units	m ³	Ugal
Full Scale Flow	ISO 4064 Qn	ISO 4064 Qn
Flow Units	m ³ /h	MUGD
Velocity Units	m/s	ft/s
Date Format from Country Code	DDMMYY	MMDDYY
Flow Response Time (s)	3	3
Display Flow Rate	Yes	Yes
Display Forward Total	Yes	Yes
Display Date	No	No
Display Velocity	No	No
Output Option Pulse Forward	Pulses Forward	Pulses Forward
Encoder Source	Forward Total	Forward Total

Terminal Box – Sensor Mounted

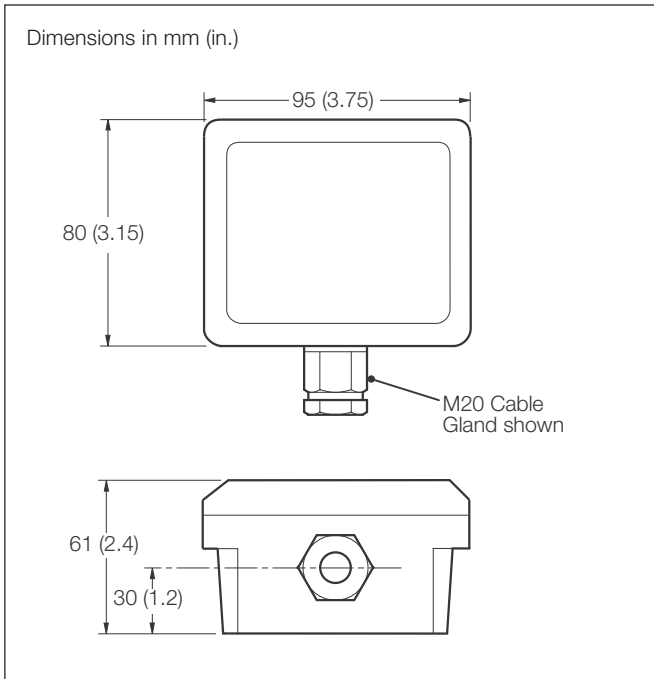

Transmitter

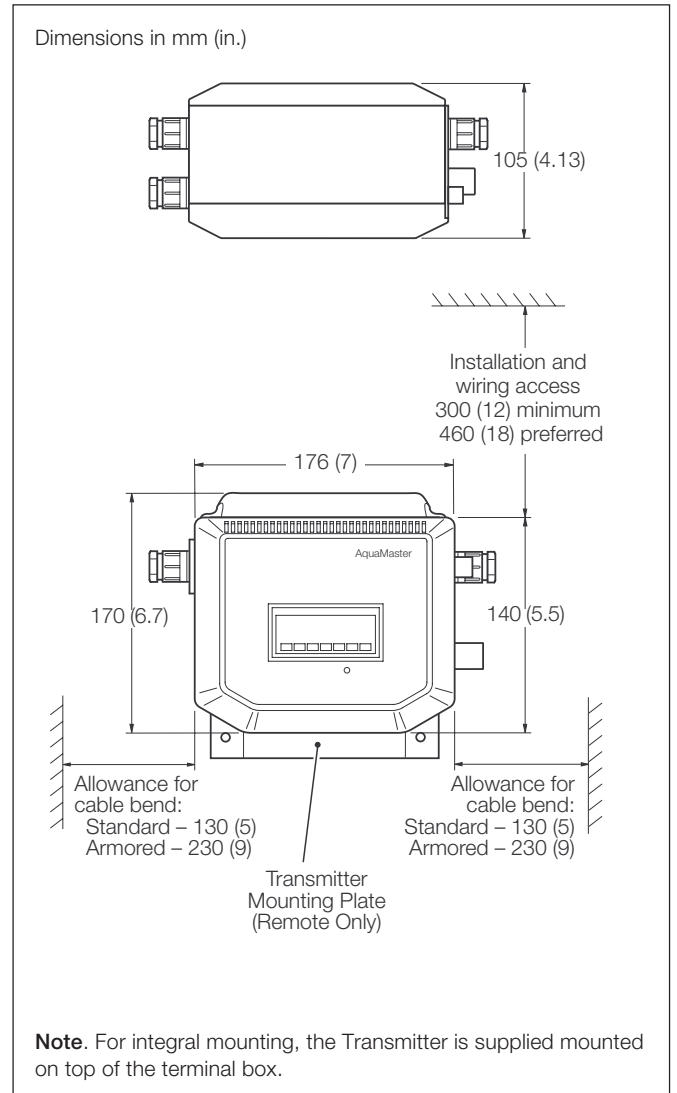

Ordering Information

Main Code

Additional Code

AquaMaster Electronic Water Meter System			MM/G A	X	XXXX	X	X	X	X	X
Country	Default Flange Type 50 to 300mm	Default Cable Entry								
Australia	AS4087 Class 16	20/16mm		A						
Germany	ISO7005 PN16	20/16mm		D						
Spain	ISO7005 PN16	20/16mm		E						
France	ISO7005 PN16	20/16mm		F						
UK	ISO7005 PN16	20/16mm		G						
Holland	ISO7005 PN16	20/16mm		H						
Italy	ISO7005 PN16	20/16mm		I						
USA	ANSI B 16.5 Class 150	1/2 in. NPT		U						
Calibrated Bore										
	mm	in.								
	50	2			0050					
	65	2 1/2			0065					
	80	3			0080					
	100	4			0100					
	150	6			0150					
	200	8			0200					
	250	10			0250					
	300	12			0300					
Transmitter Version & Mounting										
Integral with Sensor Horizontal Display (DN50 to 300)										1
Integral with Sensor Vertical Display										2
Remote from Sensor										3
Close-coupled with Sensor, Horizontal Display, Metal Transmitter (DN40 to 600)										A
Close-coupled with Sensor, Vertical Display, Metal Transmitter (DN40 to 600)										B
Close-coupled Sensor only, to suit Explorer Transmitter (DN40 to 600, Transmitter ordered separately under code AM/E)										D
Remote Sensor only, to suit Explorer Transmitter (DN40 to 600, Transmitter ordered separately under code AM/E)										E
Power Supply										
Battery										B
Options										
With Earthing Rings (≥DN100)										2
With Earthing Rings (≥DN100) & Potting for Transmitter termination wiring										C
Cable Length										
Not Required										0
10m										1
20m										2
30m										3
40m										4
50m										5
60m										6
70m										7
80m										8
100m										A
125m										B
150m										C
175m										D
200m										E

X	X	X	0	X	0	0	X	0	0	0
---	---	---	---	---	---	---	---	---	---	---

Main Code							Additional Code											
MM/GA	X	XXXX	X	X	X	X	X	X	0	X	0	0	X	0	0	0		
Labelling/Construction																		
ABB UK							0											
ABB USA							1											
Flange Style/End Connections																		
As defined by Country digit (see page 10)							0											
AS4087 Class 14 Flanges							A											
AS4087 Class 16 Flanges							Z											
AS2129 Table C Flanges							C											
AS2129 Table D Flanges							D											
AS2129 Table E Flanges (50 to 80mm [2 to 3 in.] only)							H											
ISO7005 PN10 Flanged							M											
ISO7005 PN16 Flanged							E											
ANSI B16.5 Class 150 Flanged (1.5 to 12 in. only)							U											
BS10 Table D Flanged							F											
BS10 Table E Flanged							G											
JIS B2210, 5k Flanged							L											
JIS B2210, 10k Flanged							J											
Cable Entries																		
As defined by Country digit (see page 10). Cable not fitted/potted to sensor							0											
20/16mm plastic glands. Cable not fitted/potted to sensor							1											
20/16mm plastic glands. Cable fitted/potted to sensor							B											
1/2in NPT(USA only). Cable not fitted/potted to sensor							3											
20mm armored. Cable not fitted/potted to sensor							2											
20mm armored. Cable fitted/potted to sensor							C											
MIL connector (sensor) + 16mm plastic glands. Cable fitted/potted to remote sensor							5											
MIL connector (sensor) + 19-way MIL connector +16mm plastic gland. Cable fitted/potted to remote sensor							6											
20mm armored (Sensor) + 16mm plastic glands. Cable not fitted to sensor.							7											
20mm armored (Sensor) + 16mm plastic glands. Cable fitted/potted to sensor.							D											
Not Used										0								
Calibration																		
1 Point (with pressure test)											7							
3 Point (with pressure test)											8							
Not used												0	0					
Communications Option																		
Not required																0		
Remote port RS232 C																1		
ABB encoder interface																2		
ABB encoder interface with 5m cable																3		

Connection Information



ABB has Sales & Customer Support expertise in over 100 countries worldwide

www.abb.com

The Company's policy is one of continuous product improvement and the right is reserved to modify the information contained herein without notice.

Printed in UK (11.04)

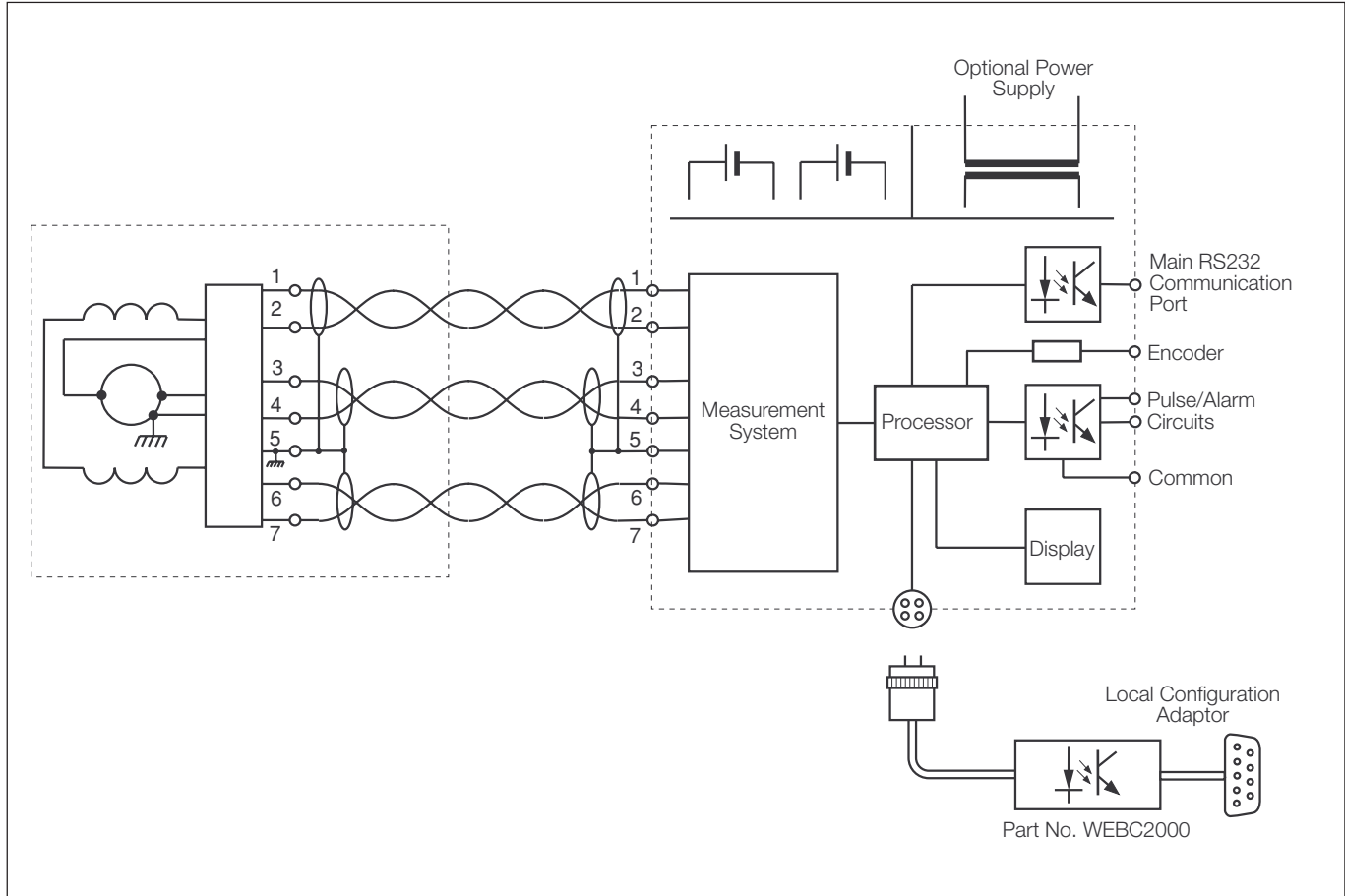
© ABB 2004



ABB Limited
Oldends Lane, Stonehouse
Gloucestershire
GL10 3TA
UK
Tel: +44 (0)1453 826661
Fax: +44 (0)1453 829671

ABB Inc.
125 E. County Line Road
Warminster
PA 18974
USA
Tel: +1 215 674 6000
Fax: +1 215 674 7183