

EXFG Oxygen Analyzer System (ATEX)

Oxygen Transmitters –
4680 & 4685



The Company

We are an established world force in the design and manufacture of instrumentation for industrial process control, flow measurement, gas and liquid analysis and environmental applications.

As a part of ABB, a world leader in process automation technology, we offer customers application expertise, service and support worldwide.

We are committed to teamwork, high quality manufacturing, advanced technology and unrivalled service and support.

The quality, accuracy and performance of the Company's products result from over 100 years experience, combined with a continuous program of innovative design and development to incorporate the latest technology.

The UKAS Calibration Laboratory No. 0255 is just one of the ten flow calibration plants operated by the Company and is indicative of our dedication to quality and accuracy.

EN ISO 9001:2000



Cert. No. Q 05907

EN 29001 (ISO 9001)



Lenno, Italy – Cert. No. 9/90A

Stonehouse, U.K.



0255

Electrical Safety

This equipment complies with the requirements of CEI/IEC 61010-1:2001-2 "Safety requirements for electrical equipment for measurement, control, and laboratory use". If the equipment is used in a manner NOT specified by the Company, the protection provided by the equipment may be impaired.

Symbols

One or more of the following symbols may appear on the equipment labelling:

	Warning – Refer to the manual for instructions		Direct current supply only
	Caution – Risk of electric shock		Alternating current supply only
	Protective earth (ground) terminal		Both direct and alternating current supply
	Earth (ground) terminal		The equipment is protected through double insulation

Information in this manual is intended only to assist our customers in the efficient operation of our equipment. Use of this manual for any other purpose is specifically prohibited and its contents are not to be reproduced in full or part without prior approval of the Technical Publications Department.

Health and Safety

To ensure that our products are safe and without risk to health, the following points must be noted:

1. The relevant sections of these instructions must be read carefully before proceeding.
2. Warning labels on containers and packages must be observed.
3. Installation, operation, maintenance and servicing must only be carried out by suitably trained personnel and in accordance with the information given.
4. Normal safety precautions must be taken to avoid the possibility of an accident occurring when operating in conditions of high pressure and/or temperature.
5. Chemicals must be stored away from heat, protected from temperature extremes and powders kept dry. Normal safe handling procedures must be used.
6. When disposing of chemicals ensure that no two chemicals are mixed.

Safety advice concerning the use of the equipment described in this manual or any relevant hazard data sheets (where applicable) may be obtained from the Company address on the back cover, together with servicing and spares information.

CONTENTS

1	INTRODUCTION	1
1.1	Documentation	1
1.2	System Hardware	2
1.3	Principle of Operation	2
2	PREPARATION	3
2.1	Checking the Instrument Type	3
2.1.1	Wall-mounted Instruments	3
2.1.2	Panel-mounted Instruments	3
3	MECHANICAL INSTALLATION	3
3.1	Siting Requirements	3
3.2	Mounting	4
3.2.1	Wall/Pipe-mounted Instruments	4
3.2.2	Panel-mounted Instruments	5
4	ELECTRICAL CONNECTIONS	6
4.1	Connections – General	6
4.1.1	Cable and Gland Specifications	6
4.1.2	Relay Contact Protection and Interference Suppression	7
4.2	Wall-mounted Instrument Connections	8
4.3	Panel-mounted Instrument Connections	10
4.4	Selecting the Mains Voltage	12
4.4.1	Wall/Pipe-mounted Instruments	12
4.4.2	Panel-mounted Instruments	12
5	CONTROLS AND DISPLAYS	13
5.1	Displays	13
5.2	Switch Familiarization	13
6	OPERATION	14
6.1	Instrument Start-up	14
6.2	Operating Page	14
6.2.1	Operating Page Error Messages	14
7	PROGRAMMING	15
7.1	Access to Secure Parameters	15
7.2	Language Page	15
7.3	Set Up Outputs Page	16

1 INTRODUCTION

1.1 Documentation

Documentation for the EXFG Oxygen Analyzer System is shown in Fig. 1.1.

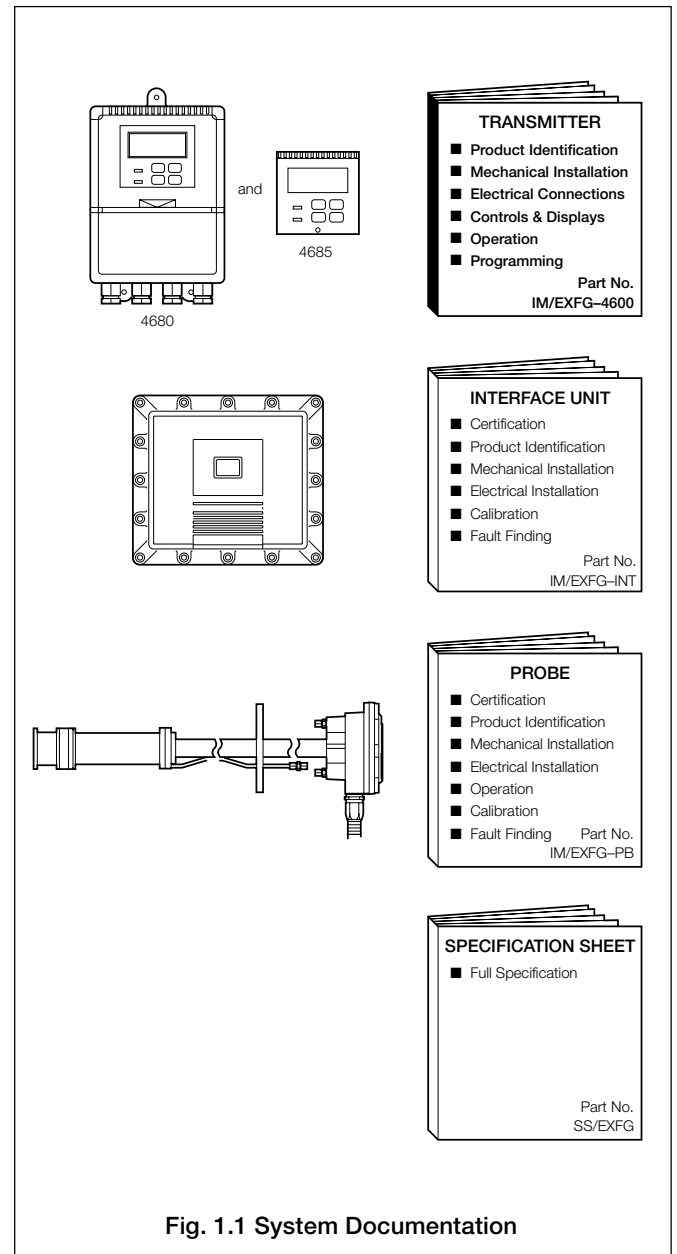

Fig. 1.1 System Documentation

...1 INTRODUCTION

1.2 System Hardware – Fig. 1.2

The 4680 and 4685 transmitters are part of the EXFG Oxygen Analyzer System which measures oxygen content and temperature within a gas flue. The 4680/500 model is a wall-mounted instrument and the 4685/500 model is a panel-mounted, DIN-sized instrument. Signals from either transmitter can also be retransmitted to remote monitoring equipment.

Both models have a single programmable input channel and a single temperature input channel. Instrument operation and programming is via four tactile membrane switches located on the front panel. Programmed functions are protected from unauthorized alteration by a five-digit security code.

1.3 Principle of Operation– Fig. 1.2

The transmitter unit processes a 4 to 20mA (25% to 0.25% O₂) signal generated at the Interface Electronics Unit and displays the oxygen value in O₂ with selectable ranges (log or linear). All ranges can be retransmitted.

In addition, the transmitter processes any alarm signals generated from the Interface Electronics Unit – see the *EXFG Probe Guide* and *EXFG Interface Electronics Unit Guide* for additional system operating information.

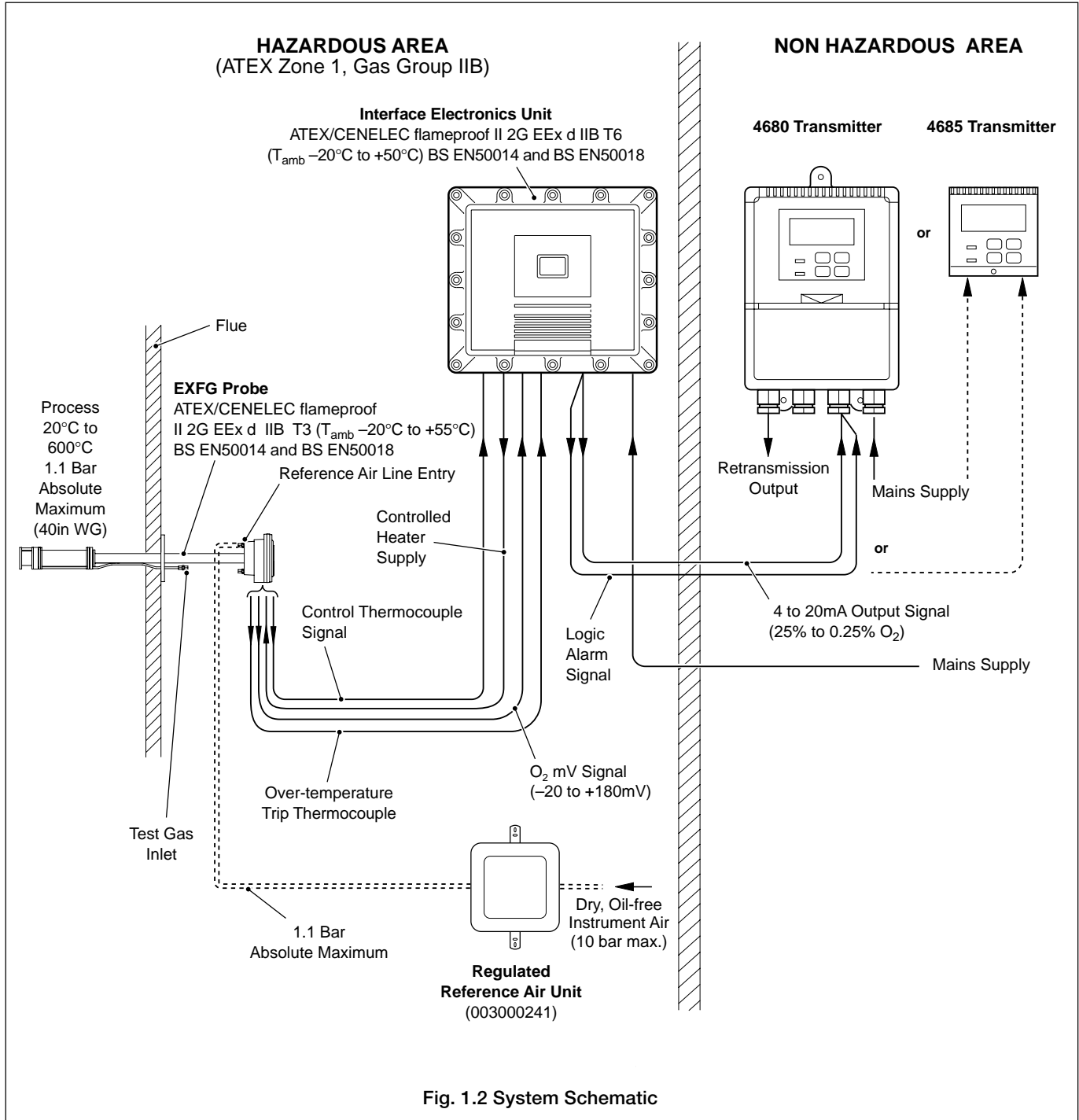

2 PREPARATION

2.1 Checking the Instrument Type

2.1.1 Wall-mounted Instruments – Fig. 2.1

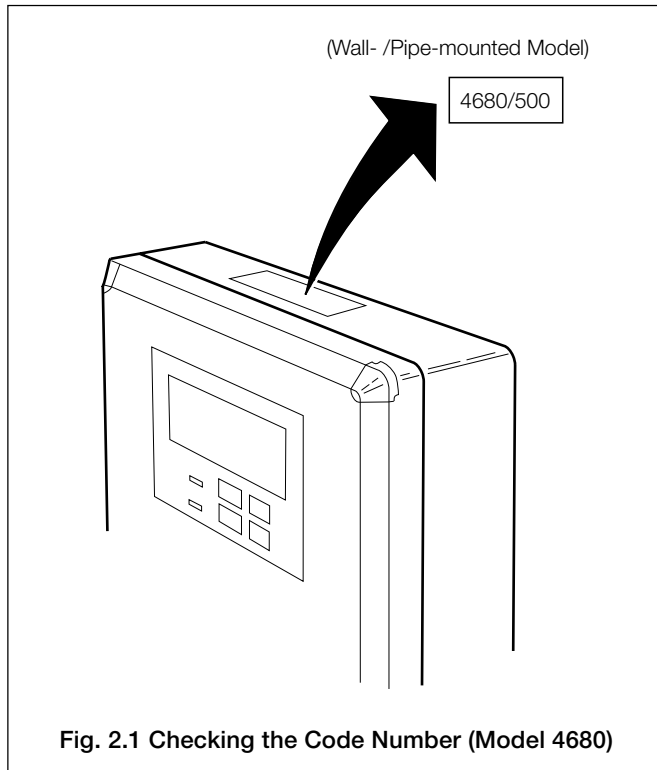

2.1.2 Panel-mounted Instruments – Fig. 2.2

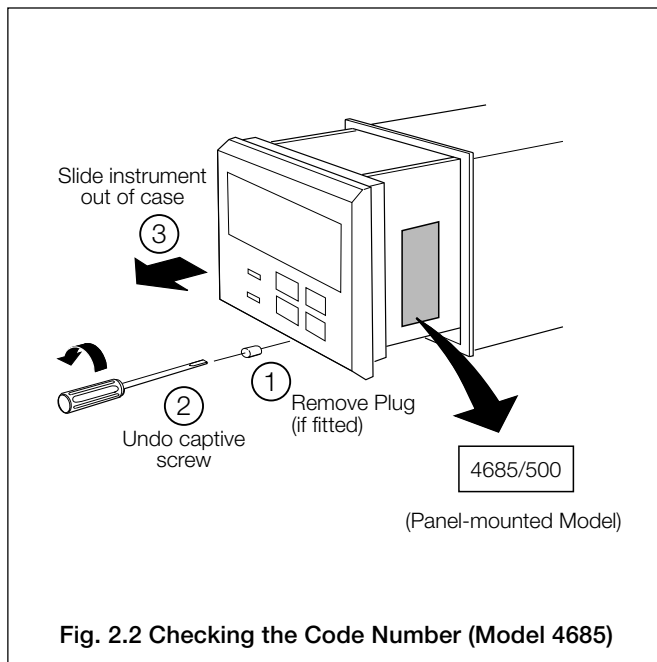

3 MECHANICAL INSTALLATION

3.1 Siting Requirements – Fig. 3.1

Caution.

- Mount in a location free from excessive vibration.
- Mount away from harmful vapors and/or dripping fluids.

Information.

It is preferable to mount the instrument at eye level, allowing an unrestricted view of the front panel displays and controls.

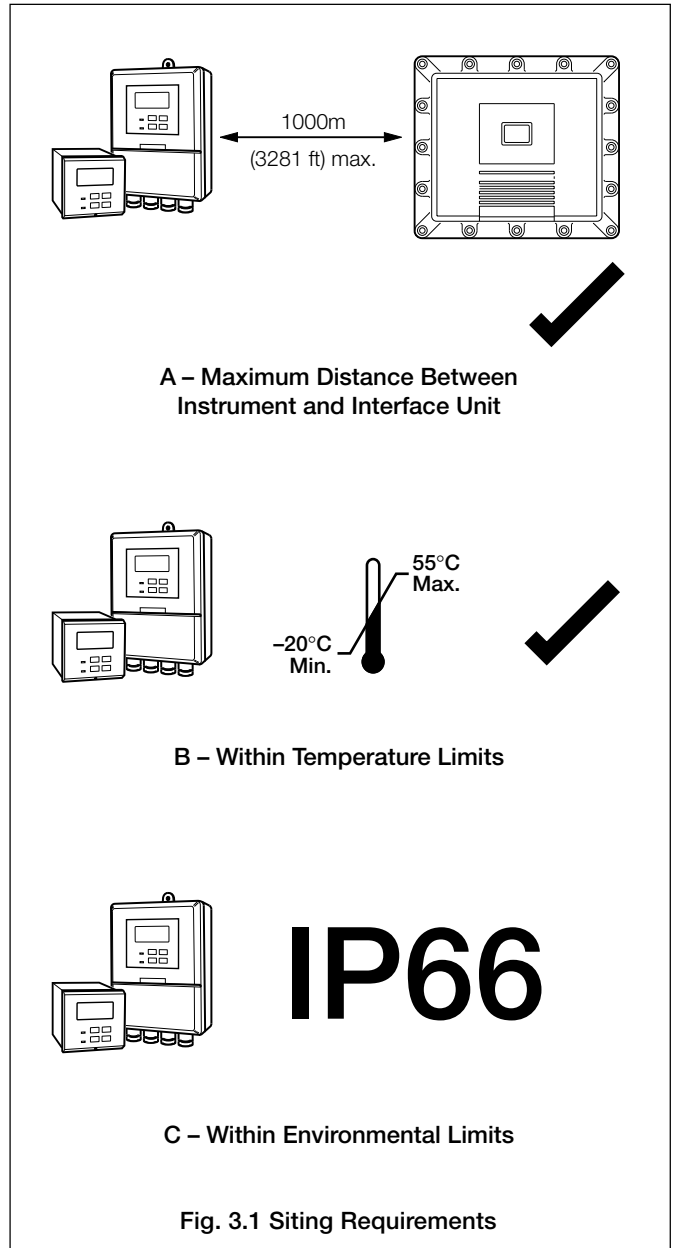

...3 MECHANICAL INSTALLATION

3.2 Mounting

3.2.1 Wall/Pipe-mounted Instruments – Figs. 3.2 and 3.3

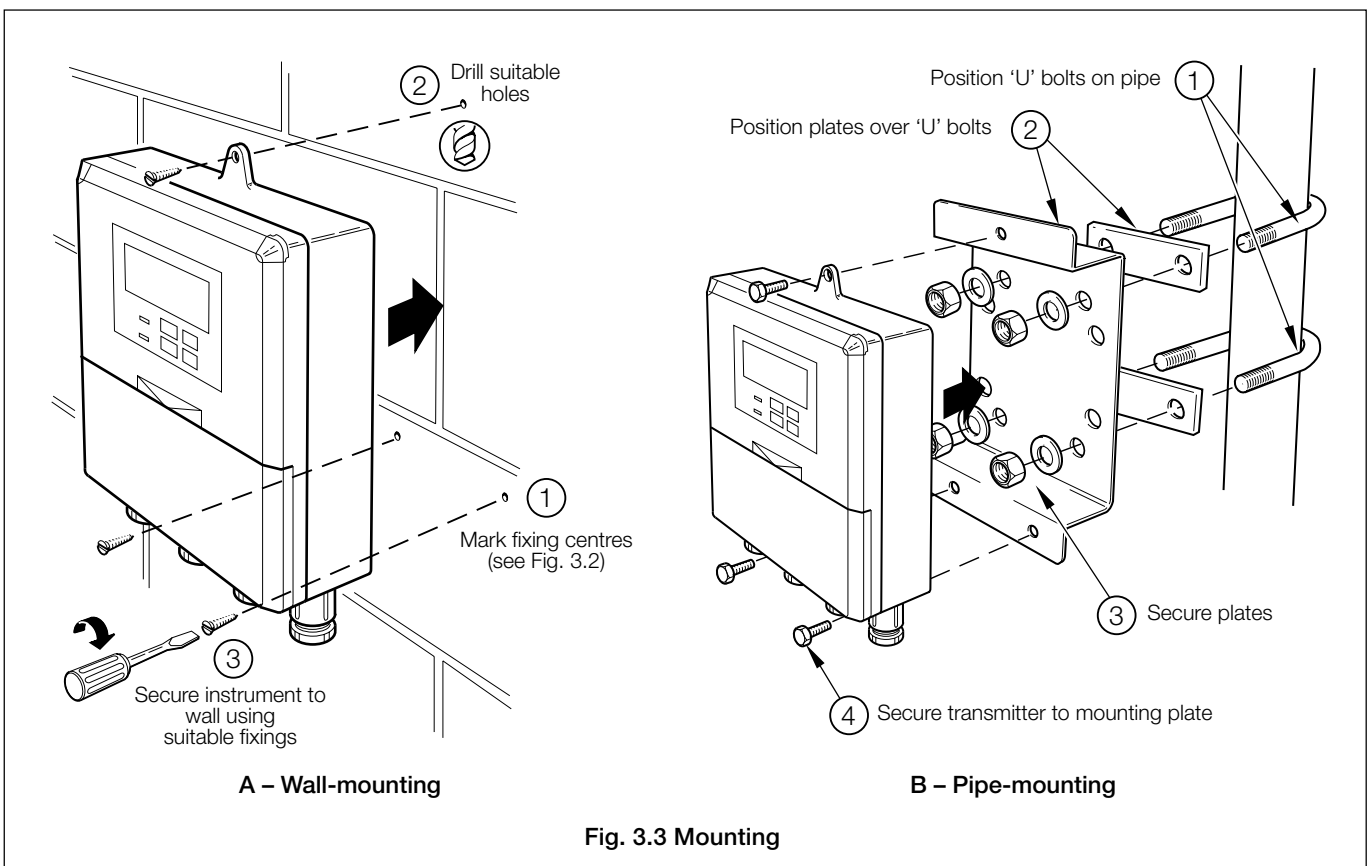
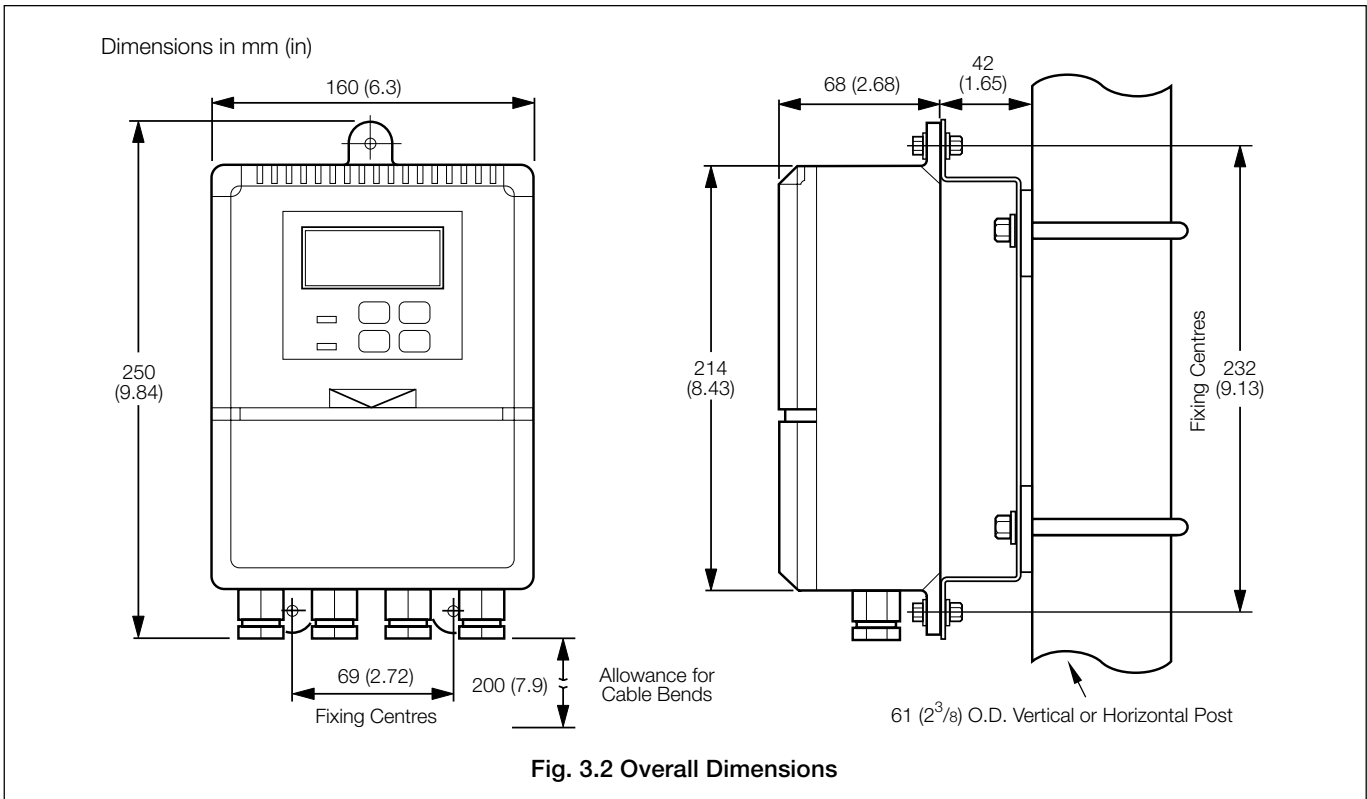

...3.2 Mounting

3.2.2 Panel-mounted Instruments – Figs. 3.4 and 3.5

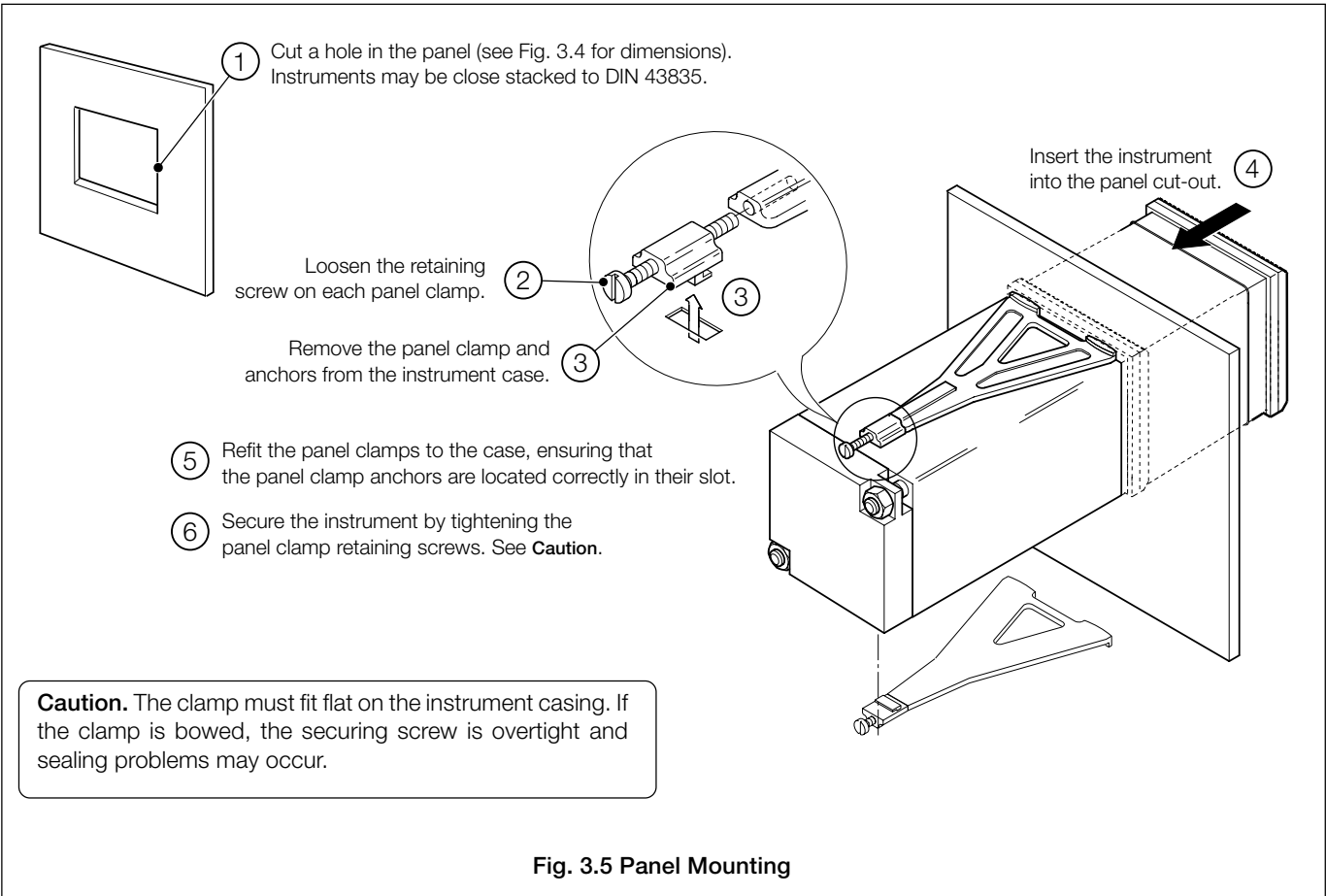
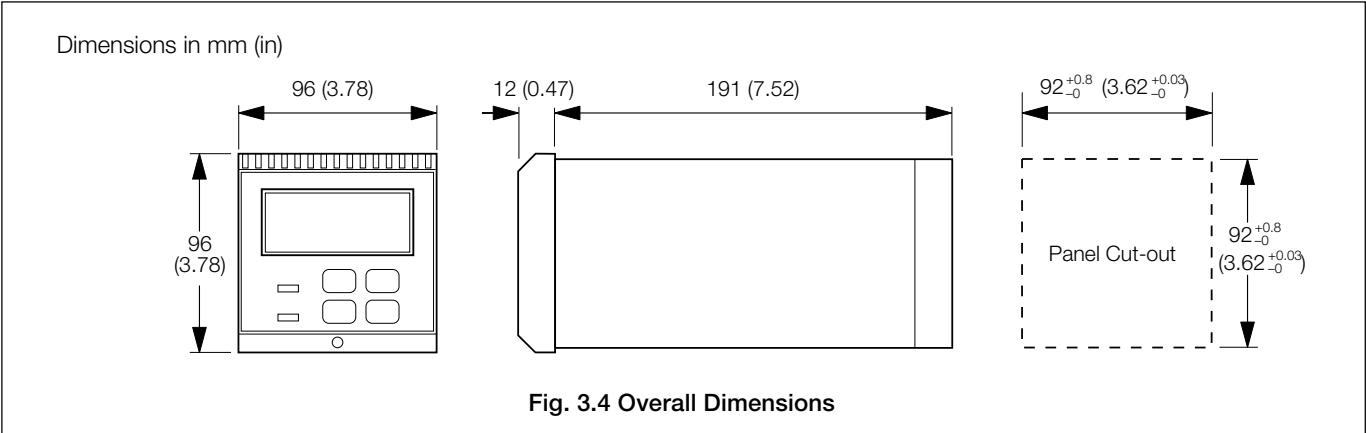

4 ELECTRICAL CONNECTIONS

4.1 Connections – General

Warning.

- **Mains power** – before making any connections, ensure that the power supply, any high voltage-operated control circuits and high common mode voltages are switched off.

Information.

- **Earthing (grounding)** – stud terminal(s) is fitted to the transmitter case for bus-bar earth (ground) connection – see Fig. 4.2 or 4.5.
- **Cable routing** – always route signal output cable leads and mains-carrying/relay cables separately, ideally in earthed metal conduit. Twist the signal output leads together or use screened cable with the screen connected to the case earth stud. Ensure that the cables enter the transmitter through the glands nearest the appropriate screw terminals and are short and direct. Do not tuck excess cable into the terminal compartment.
- **Cable glands & conduit fittings** – ensure a moisture-tight fit when using cable glands, conduit fittings and blanking plugs/bungs (M20 holes).
- **Relays** – the relay contacts are voltage-free and must be appropriately connected in series with the power supply and the alarm/control device which they are to actuate. Ensure that the contact rating is not exceeded. Refer also to Section 4.1.2 for relay contact protection details when the relays are to be used for switching loads.
- **Retransmission output** – Do not exceed the maximum load specification for the selected current retransmission range (see the associated Specification sheet). Because the retransmission output is isolated the –ve terminal **must** be connected to earth (ground) if connecting to the isolated input of another device.

4.1.1 Cable and Gland Specifications

Caution.

- **Cabling** – connections between the Transmitter and the Interface Electronics Unit must be suitable for use with type 'd' Protection Flameproof Enclosures.
- **Glands** – EEx d glands used on the Interface Electronics Unit must be of the certified flameproof 'Barrier Gland' type because the enclosure is over 2 liters volume, has a source of ignition within and is designed for use in Zone 1 areas.

Information.

- The M20 glands ready-fitted to wall-mounted instruments accept cable of between 4 and 7mm diameter.
- A spare set of grommets is supplied for cable sizes between 8 and 12mm diameter.

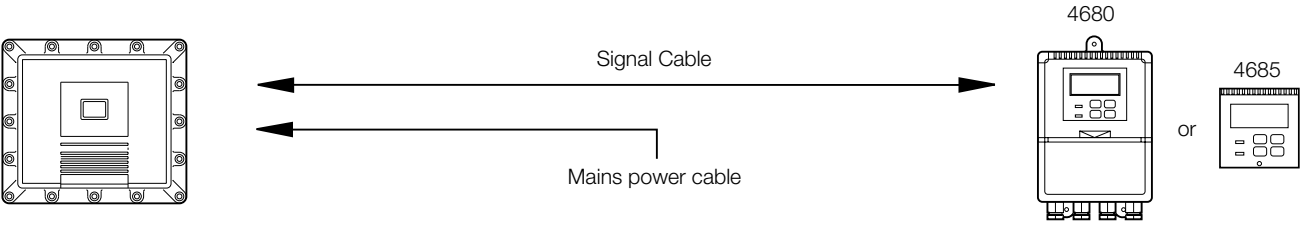

Gland Specification	Cable Specifications		Gland Specification	
M20 flameproof certified EEx d barrier gland (not supplied)	Signal cable (not supplied)	16/0.2, 4-core copper, overall screened, flameproof (two pairs) Max. loop resistance 750Ω	4680 M20 Uncertified (fitted)	4685 No gland required
M20 flameproof certified EEx d barrier gland (not supplied)	Mains power cable (not supplied)	3-core, 0.5mm ² copper (min.)	4680 M20 Uncertified (fitted)	4685 No gland required

Table 4.1 Cable and Gland Specifications (electrical requirements only)

...4 ELECTRICAL CONNECTIONS

4.2 Wall-mounted Instrument Connections – Figs. 4.2 and 4.3

Caution. Slacken terminal screws fully before making connections.

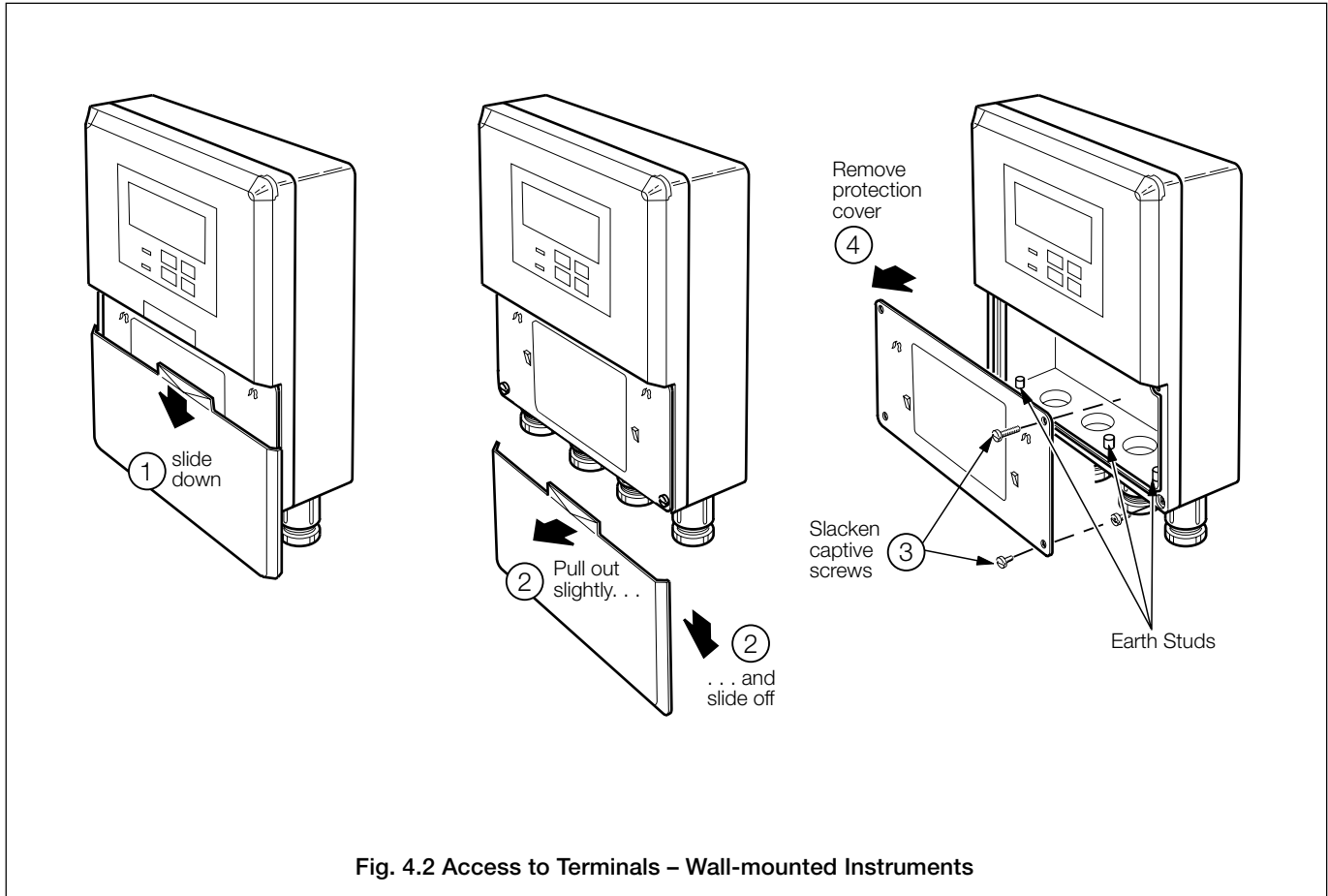
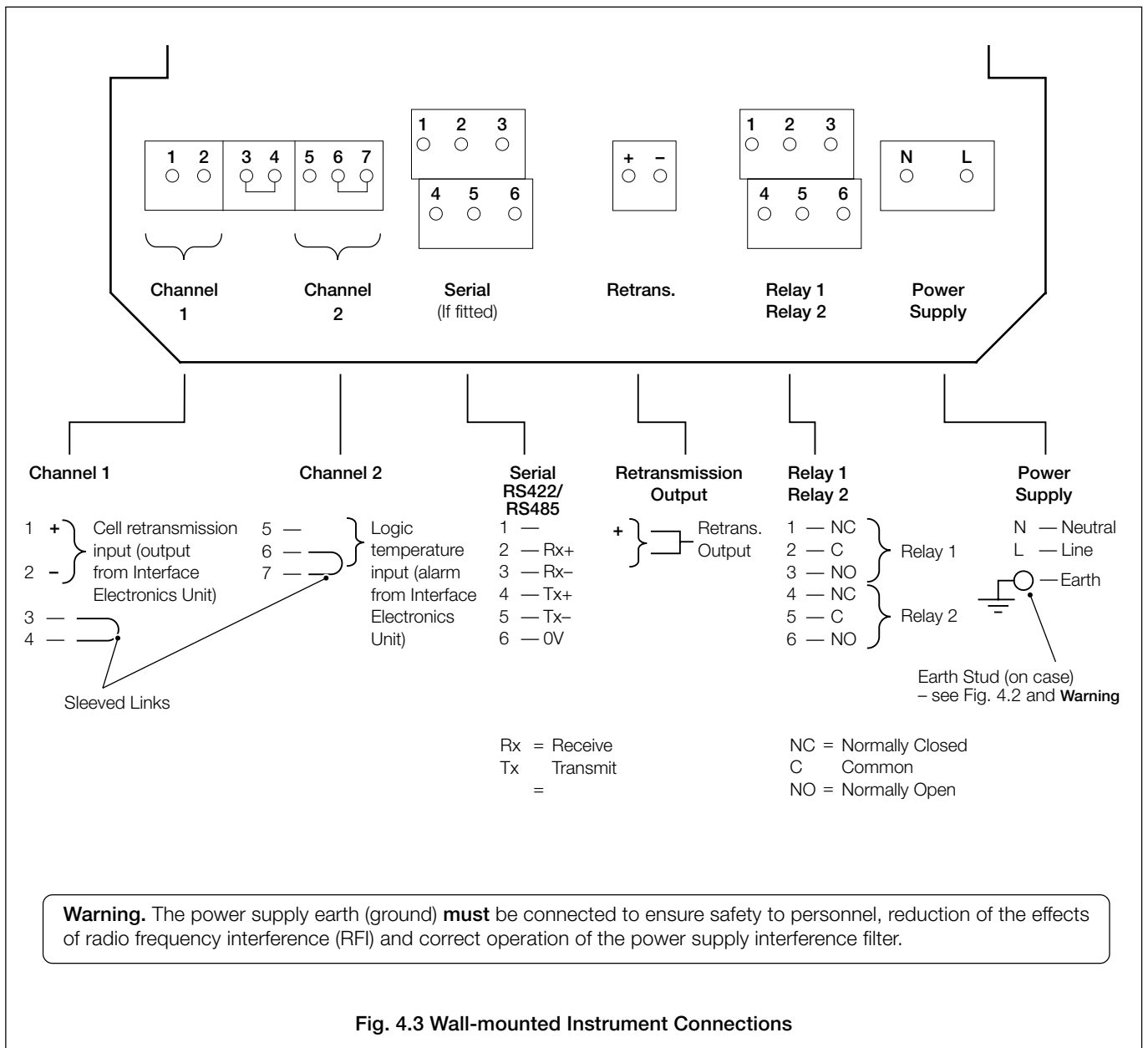

Fig. 4.2 Access to Terminals – Wall-mounted Instruments

...4.2 Wall-mounted Instrument Connections – Figs. 4.2 and 4.3



...4 ELECTRICAL CONNECTIONS

4.3 Panel-mounted Instrument Connections – Figs. 4.4 and 4.5

Caution. Slacken terminal screws fully before making connections.

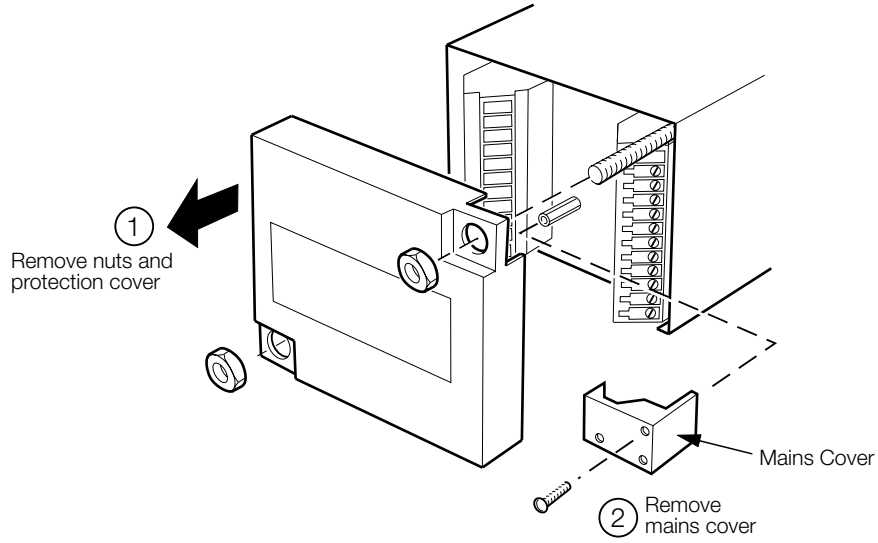
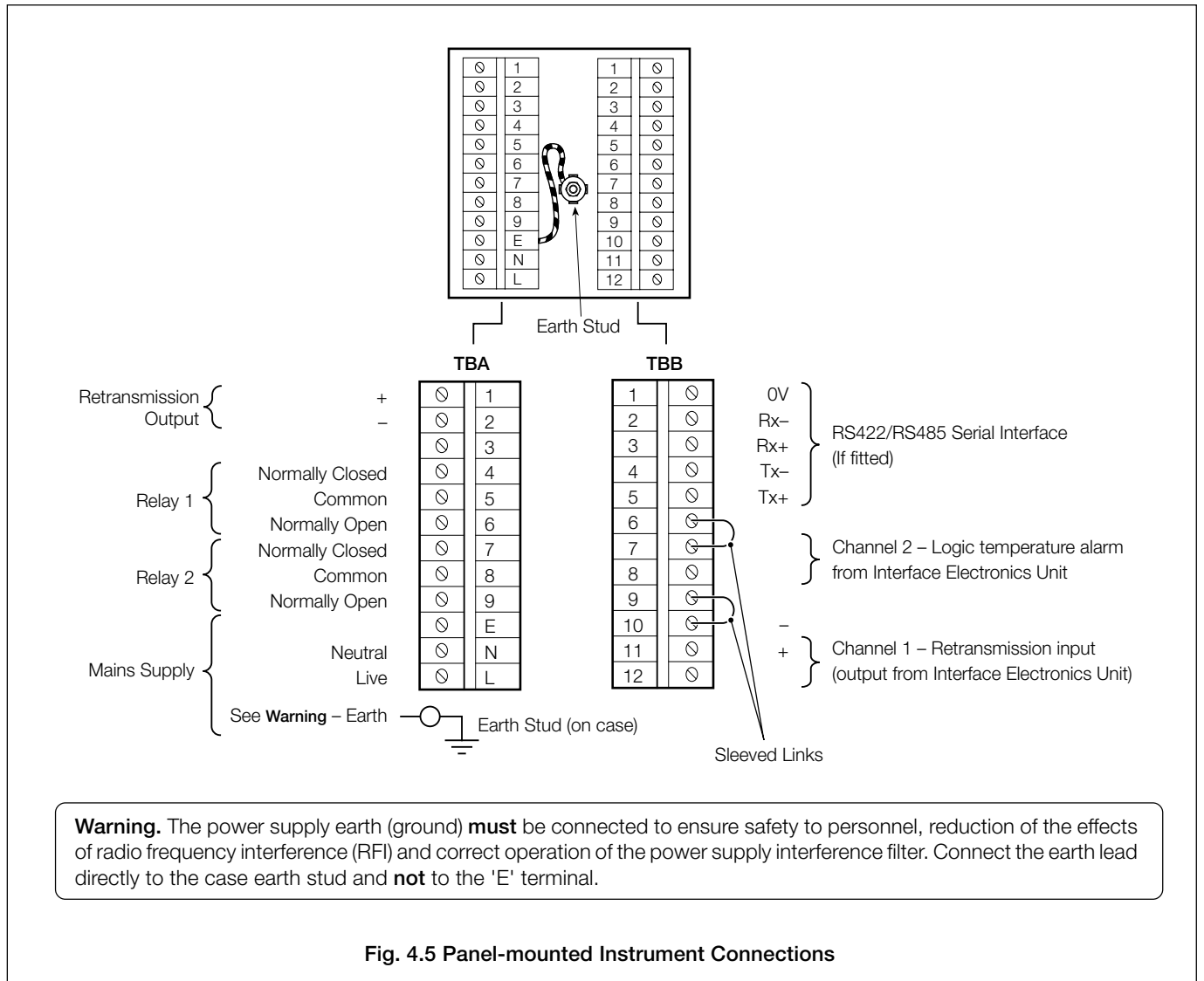

Fig. 4.4 Access to Terminals – Panel-mounted Instruments

...4.3 Panel-mounted Instrument Connections – Figs. 4.4 and 4.5



Warning. The power supply earth (ground) **must** be connected to ensure safety to personnel, reduction of the effects of radio frequency interference (RFI) and correct operation of the power supply interference filter. Connect the earth lead directly to the case earth stud and **not** to the 'E' terminal.

Fig. 4.5 Panel-mounted Instrument Connections

...4 ELECTRICAL CONNECTIONS

4.4 Selecting the Mains Voltage

4.4.1 Wall/Pipe-mounted Instruments – Fig. 4.6

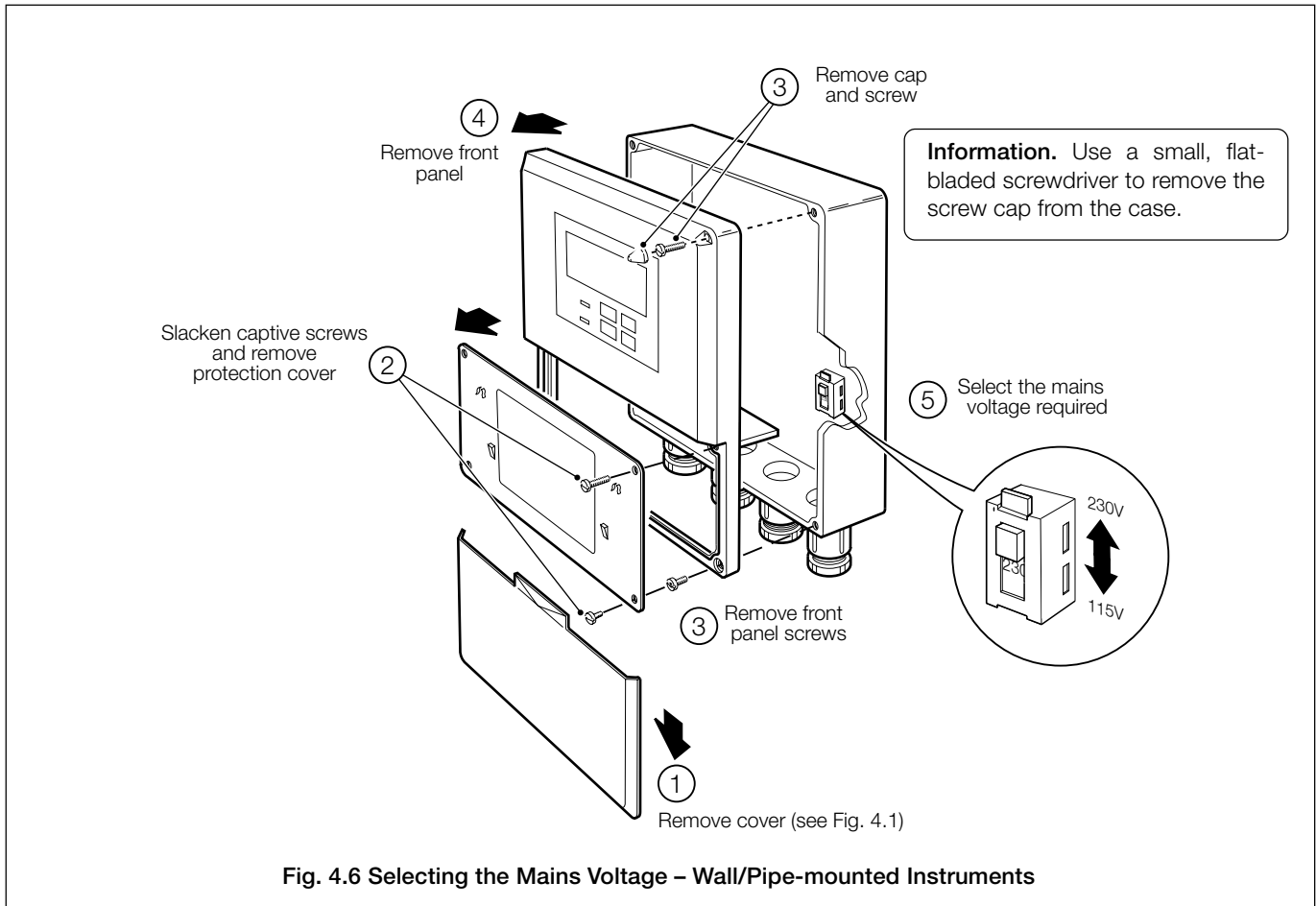

4.4.2 Panel-mounted Instruments – Fig. 4.7

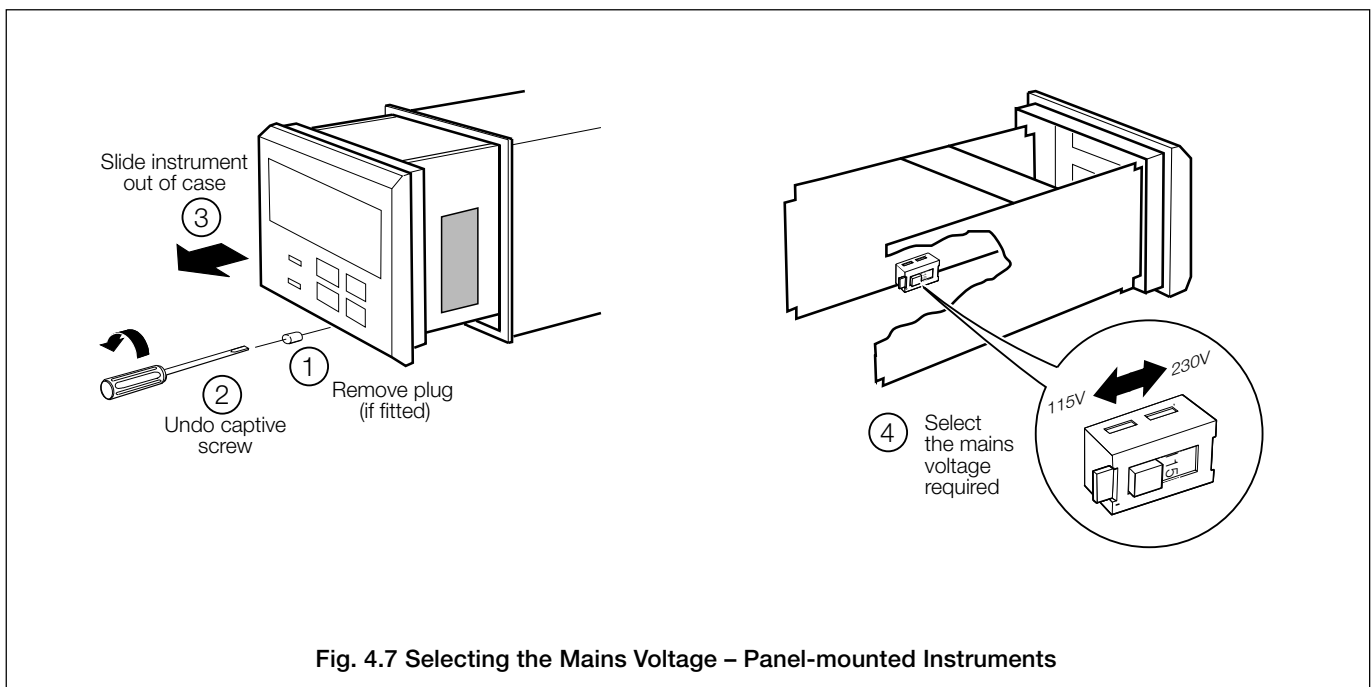

5 CONTROLS AND DISPLAYS

5.1 Displays – Fig. 5.1

The display comprises a 5-digit, 7-segment digital upper display line and a 16-character dot-matrix lower display line. The upper display line shows actual values of oxygen, alarm set points or programmable parameters. The lower display line shows the associated units or programming information.

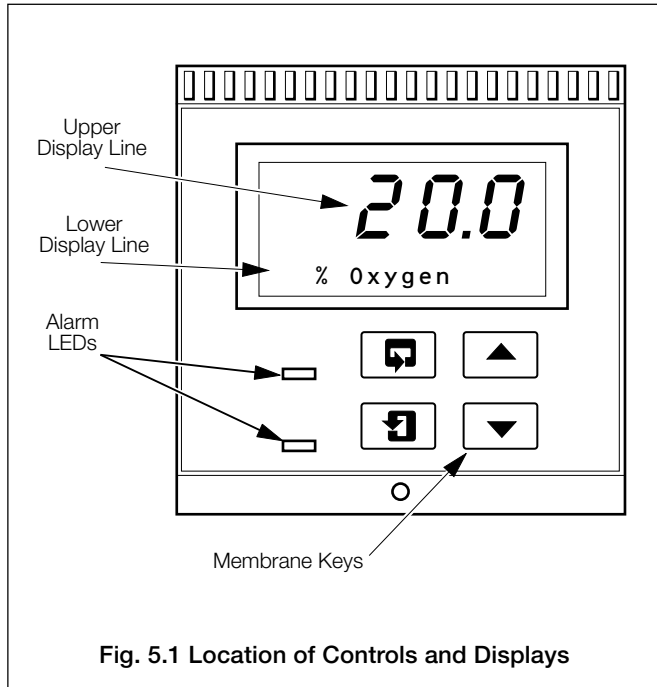
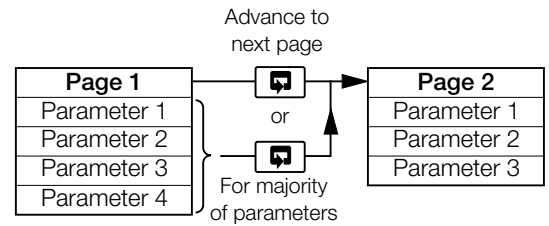
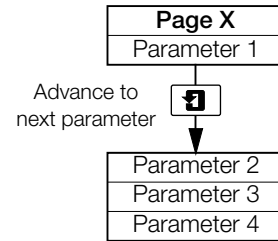

Fig. 5.1 Location of Controls and Displays

5.2 Switch Familiarization



A – Advancing to Next Page



B – Moving Between Parameters

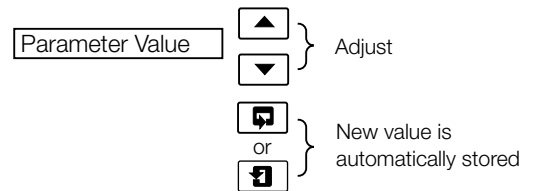

C – Adjusting and Storing a Parameter Value

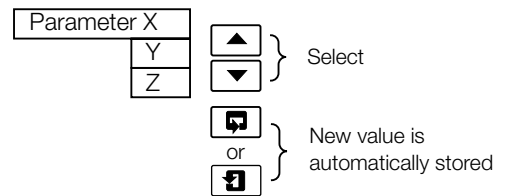

D – Selecting and Storing a Parameter Choice

Fig. 5.2 Membrane Switch Functions

6 OPERATION

6.1 Instrument Start-up

Ensure all electrical connections have been made correctly and switch on.

6.2 Operating Page

The **Operating Page** is a general use page in which parameters are viewed only and cannot be altered. To alter or program a parameter refer to the programming pages in Section 7.

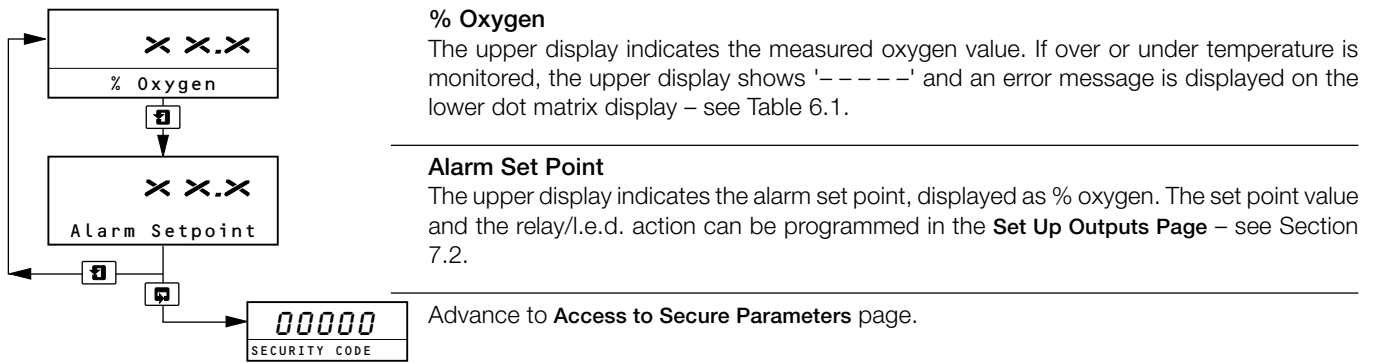

6.2.1 Operating Page Error Messages

The following error messages only appear in the **Operating Page** (when an error has been detected), in place of the % oxygen frame.

Note. Relay 2 is assigned as a malfunction alarm and de-energizes when an error condition is present. The LED assigned to this relay is illuminated when in an error condition.

Error Message	Possible Cause
NV MEMORY ERROR	The contents of the non-volatile memory have not been read correctly during power up. To rectify the fault, switch off, wait 10 seconds and switch on again. If the fault persists contact the Manufacturer.
CELL UNDER TEMP.	The temperature at the probe sensor has not reached a sufficient temperature to obtain suitable readings (less than 690°C at the control thermocouple).
OVER TEMP. TRIP	The temperature at the probe sensor has exceeded the maximum permissible temperature (greater than 750°C) and has now switched the power to the heater off. Refer to <i>EXFG Interface Electronics Unit Guide</i> and <i>EXFG Probe Guide</i> .
	The Interface Electronics Unit is switched off or mains power to the Interface Electronics Unit has failed.
OUT OF LIMITS	The measured % oxygen value is outside the limits of the instrument. (The upper display will flash if outside the limits of 0.25% to 25%.)

Table 6.1 Error Messages

7 PROGRAMMING

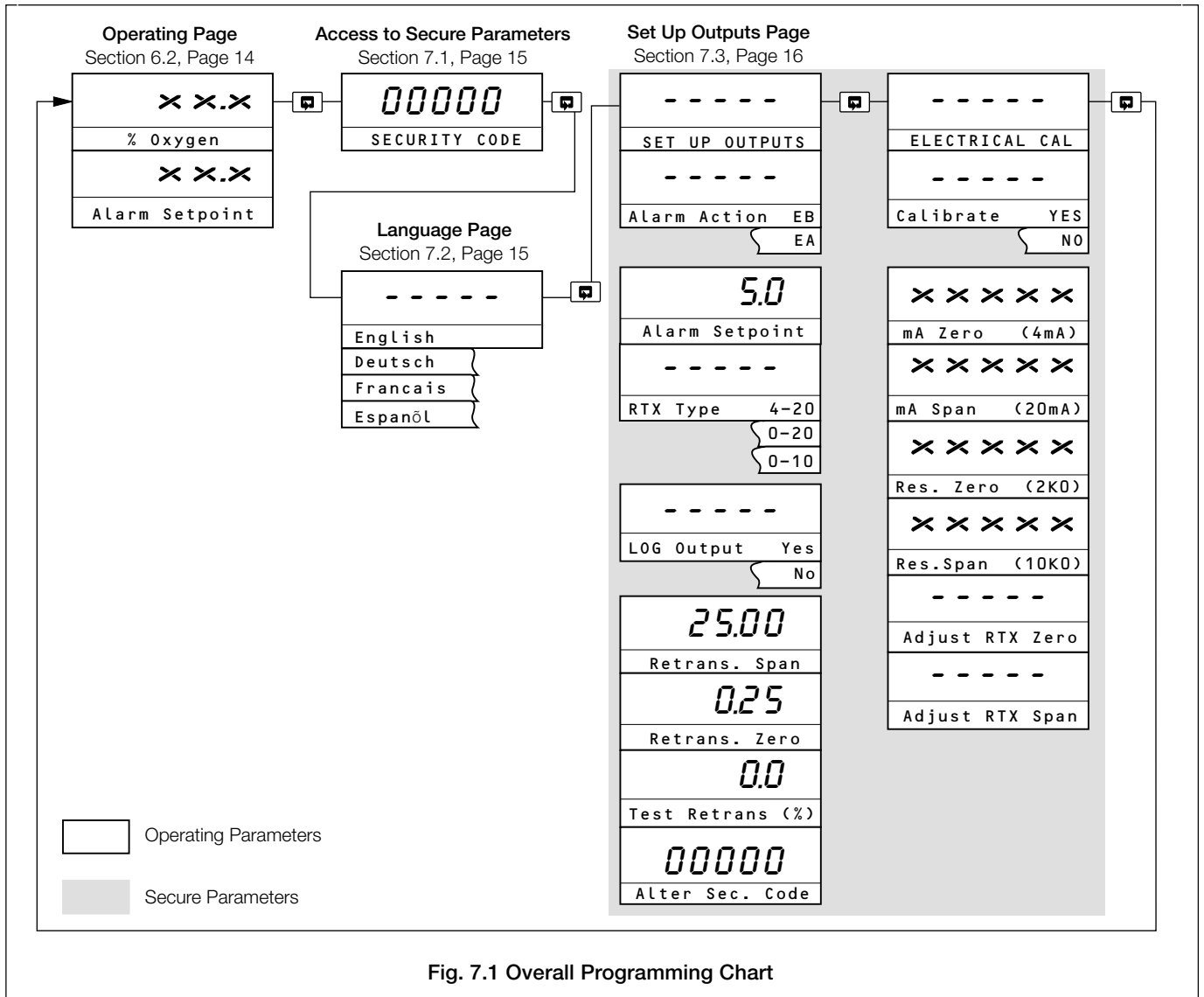
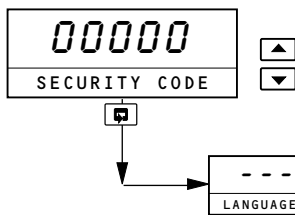

Fig. 7.1 Overall Programming Chart

7.1 Access to Secure Parameters



Security Code

Enter the required code number, between 00000 and 19999, to gain access to the secure parameters. If an incorrect value is entered, subsequent programming pages cannot be accessed.



7.2 Language Page

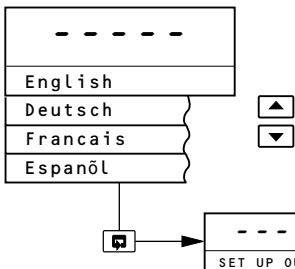

Language Page

Select the language to be displayed on all subsequent pages.



7.3 Set Up Outputs Page

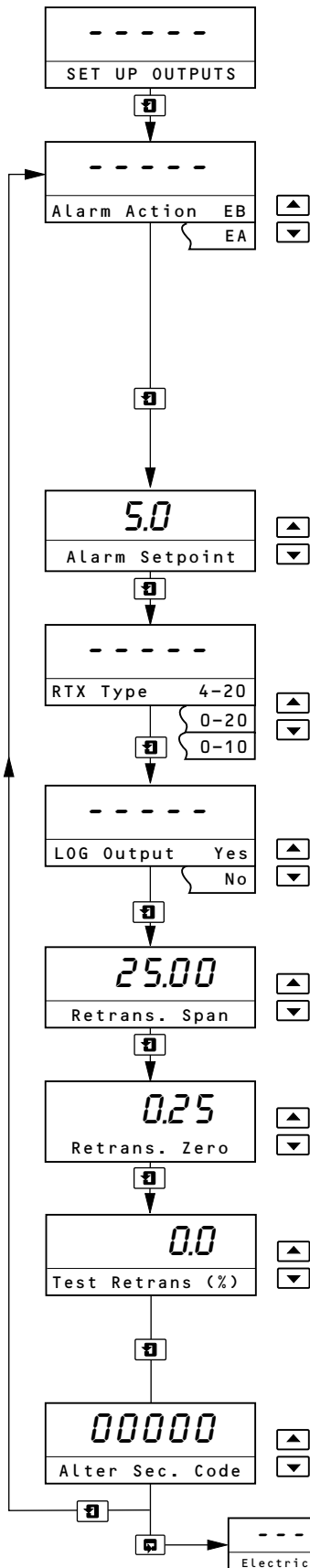

Set Up Outputs
Page header

Alarm Action

Set the required alarm action from the following table.

Alarm Action	LED Action for input Above Set Point	LED Action for input Below Set Point	LED Action for input Above Set Point	LED Action for input Above Set Point
EA	ON	OFF	OFF	ON
EA	OFF	ON	ON	OFF

The set point band is defined as the actual value of the set point plus or minus the hysteresis value. The hysteresis value is fixed at 0.1% oxygen. Alarm action occurs if the input value is above or below the set point band. If the input moves within the set point band the last alarm action is maintained.

Alarm Set Point

The alarm set point can be set to any value within the oxygen range of 0.3% to 25.0%.

Retransmission Type

The retransmission output is assigned to the oxygen range.

Select the retransmission output current range required (4 to 20mA, 0 to 20mA or 0 to 10mA).

LOG Output

The retransmission can be assigned to give a logarithmic or linear output.

Select YES for Logarithmic, NO for Linear.

Retransmission Span

Select the required retransmission span value, in % oxygen units, from 5.25% to 25.00%.

Retransmission Zero

Select the required retransmission zero value, in % oxygen units, from 0.25% to 20.00%.

Test Retransmission

The instrument automatically transmits a test signal of 0, 25, 50, 75 and 100% of the retransmission range selected above. The % test signal selected is shown on the upper display.

Example: for a selected range of 0 to 20mA and 50% retransmission test signal, 10mA is transmitted.

Alter Security Code

Set the security code to a value between 00000 and 199999.

Advance to **Electrical Calibration** page.

Note. Electrical calibration is carried out prior to despatch and should not be altered. However, if inaccurate or inconsistent readings are obtained, refer to the *Electrical Calibration Supplement* for full calibration procedures.

PRODUCTS & CUSTOMER SUPPORT

Products

Automation Systems

- *for the following industries:*
 - Chemical & Pharmaceutical
 - Food & Beverage
 - Manufacturing
 - Metals and Minerals
 - Oil, Gas & Petrochemical
 - Pulp and Paper

Drives and Motors

- *AC and DC Drives, AC and DC Machines, AC motors to 1kV*
- *Drive systems*
- *Force Measurement*
- *Servo Drives*

Controllers & Recorders

- *Single and Multi-loop Controllers*
- *Circular Chart, Strip Chart and Paperless Recorders*
- *Paperless Recorders*
- *Process Indicators*

Flexible Automation

- *Industrial Robots and Robot Systems*

Flow Measurement

- *Electromagnetic Flowmeters*
- *Mass Flow Meters*
- *Turbine Flowmeters*
- *Flow Elements*

Marine Systems & Turbochargers

- *Electrical Systems*
- *Marine Equipment*
- *Offshore Retrofit and Refurbishment*

Process Analytics

- *Process Gas Analysis*
- *Systems Integration*

Transmitters

- *Pressure*
- *Temperature*
- *Level*
- *Interface Modules*

Valves, Actuators and Positioners

- *Control Valves*
- *Actuators*
- *Positioners*

Water, Gas & Industrial Analytics Instrumentation

- *pH, conductivity, and dissolved oxygen transmitters and sensors*
- *ammonia, nitrate, phosphate, silica, sodium, chloride, fluoride, dissolved oxygen and hydrazine analyzers.*
- *Zirconia oxygen analyzers, katharometers, hydrogen purity and purge-gas monitors, thermal conductivity.*

Customer Support

We provide a comprehensive after sales service via a Worldwide Service Organization. Contact one of the following offices for details on your nearest Service and Repair Centre.

United Kingdom

ABB Limited
Tel: +44 (0)1453 826661
Fax: +44 (0)1453 829671

United States of America

ABB Inc.
Tel: +1 775 850 4800
Fax: +1 775 850 4808

Client Warranty

Prior to installation, the equipment referred to in this manual must be stored in a clean, dry environment, in accordance with the Company's published specification.

Periodic checks must be made on the equipment's condition. In the event of a failure under warranty, the following documentation must be provided as substantiation:

1. A listing evidencing process operation and alarm logs at time of failure.
2. Copies of all storage, installation, operating and maintenance records relating to the alleged faulty unit.

ABB has Sales & Customer Support
expertise in over 100 countries worldwide

www.abb.com

The Company's policy is one of continuous product
improvement and the right is reserved to modify the
information contained herein without notice.

Printed in UK (07.05)

© ABB 2005



ABB Limited
Oldends Lane, Stonehouse
Gloucestershire
GL10 3TA
UK
Tel: +44 (0)1453 826661
Fax: +44 (0)1453 829671

ABB Inc.
Analytical Instruments
9716 S. Virginia St., Ste. E
Reno, Nevada 89521
USA
Tel: +1 775 850 4800
Fax: +1 775 850 4808