

- **Industry-specific design for the water and waste water industries in diameters from 15mm (1/2 in.) to 600mm (24in.)**
- **Wide flow range with $\pm 0.25\%$ accuracy**
- **Extended low-flow capability to ensure measurement of minimal night flows**
- **Low purchase and life costs**
- **Submersible and buriable sensor**
 - inherently suitable for use in flooded environments
 - Eliminates chambers and promotes very low installation costs
- **Designed, manufactured and calibrated to internationally accepted standards**
 - ISO 9001/NAMAS/NIST/NATA/GOST
 - Ensures reliable, maintenance-free operation
- **Three internal totalizers:
Forward, reverse and net
Forward & reverse flowrates and
comprehensive range of outputs:
current, pulse, data and HART**
 - single package satisfying all user display requirements
 - Ensures compatibility with user's control system requirements



MagMaster Loflo – bringing unsurpassed flowmetering to the Water and Waste-Water industries

Introduction

Setting the Standard

The MagMaster Loflo range, available in sizes 15mm to 600mm (1/2 in. to 24 in.), is designed specifically for use on the many diverse applications encountered in the water and waste-water industry.

The specification, features and user benefits offered by this range are based on ABB's worldwide experience in this industry and they are all targeted specifically to the industry's requirements.

Flow Performance

MagMaster Loflo has an extended operating flow range with $\pm 0.25\%$ accuracy over the majority of this extended range in both forward and reverse flow directions as standard.

Emphasis is placed on the low-flow region which is particularly important for the water industry. MagMaster Loflo sets new standards for low-flow capability and enables accurate measurement of previously unmetred night flows.

Submersible and Buriable

All MagMaster Loflo sensors have a rugged, robust construction to ensure a long, maintenance-free life under the arduous conditions experienced in the Water and Waste Industry. The sensors are, as standard, inherently submersible (IP68, NEMA 6P), thus ensuring suitability for installation in chambers and metering pits which are liable to flooding.

A unique feature of the MagMaster Loflo sensors is that all sizes are buriable. Installation merely involves excavating to the underground pipe, fitting the sensor, cabling back to the transmitter and then backfilling the hole. No metering chambers or pits are required and the overall low-cost installation is simple and fast.

Comprehensive Features

A wide range of features and user benefits are built into MagMaster as standard:

- bi-directional flow
- liquid sensing
- comprehensive test mode
- universal switch mode power supply (options are available for AC and DC supplies)
- self-diagnostics
- programmable multiple alarm capability

Assured Quality

MagMaster is designed and manufactured in accordance with international quality procedures (ISO 9001) and all flowmeters are calibrated on nationally-traceable calibration rigs to provide the end-user with complete assurance of both quality and performance of the meter. An indication of the in-built quality is the two-year warranty which is offered as standard on the MagMaster range.

Fully Featured Transmitters

MagMaster is offered with integral or remote transmitters, each being available with a choice of display, configuration and communication options to suit the application. Standard features include forward, reverse and net flow totalizers, flow rate, alarm monitoring and automatic self-diagnostics to ensure integrity. All data and values are in customer-defined units of measurement. System compatibility is assured with a choice of current, pulse, serial data and Smart HART communications.

MagMaster operating parameters may be set via local keypads, remote configurators or computers as appropriate. The software features multi-level password protection capability to prevent inadvertent programs or settings changes. Data is stored in non-volatile memory for greater than 10-year retention.

In the non-keypad variant, display data can only be changed using a magnetic wand. No operational parameters can be changed without the use of configurators and appropriate passwords.

New Performances Standards for Flow Measurement

Widest flow range, optimum accuracy and long term stable calibration mean that MagMaster LoFlo sets new performance standards in the water industry.

This unique low flow rate capability enables previously unrecordable minimal night flow rates to be metered; particularly important for bulk revenue and district metering applications.

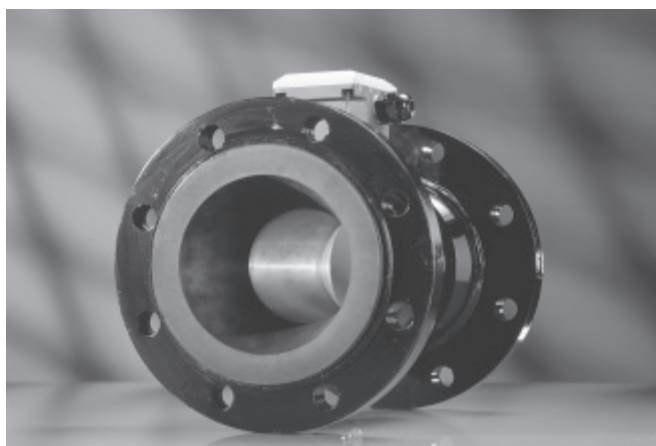

Specification – Sensor

Sizes, Accuracies and Flow Rates (under reference conditions)

Flow rate in $m^3 h^{-1}$

Sizes DN		Max.Flow $\pm 0.25\%^*$	Min. Flow $\pm 0.25\%^*$	Transition Flow $\pm 2.0\%$	Min Flow $\pm 5.00\%$
mm	in				
15	1/2	3	0.08	0.009	0.004
20	3/4	5	0.13	0.015	0.006
25	1	7	0.18	0.021	0.009
40	1 1/2	20	0.50	0.06	0.025
50	2	30	0.75	0.09	0.038
65	2 1/2	50	1.25	0.15	0.063
80	3	80	2.0	0.24	0.10
100	4	120	3.0	0.36	0.15
125	5	200	4.5	0.55	0.24
150	6	300	7.5	0.90	0.38
200	8	500	12.5	1.50	0.63
250	10	800	20	2.40	1.00
300	12	1200	30	3.60	1.50
350	14	1600	40	6.40	2.80
400	16	2000	50	8.00	3.50
450	18	2600	66	10.40	4.60
500	20	3000	76	12.00	5.30
600	24	5000	125	20.00	8.80

* Accuracy for sizes 15, 20 and 25 is $\pm 0.35\%$

Flow Ranges

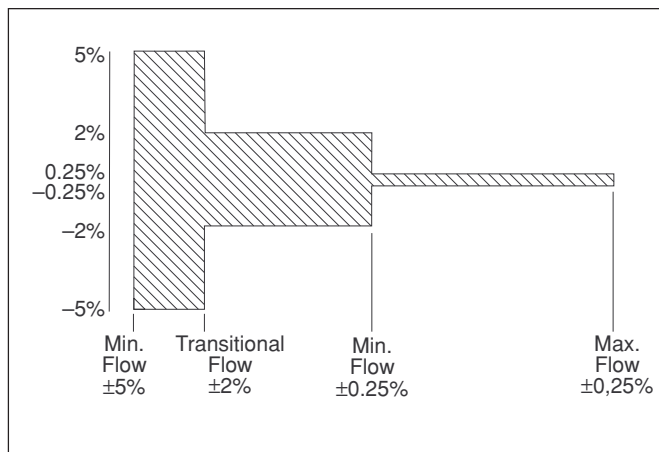

Accuracy (under forward flow reference conditions)

as 'Flow Rate' table, plus the following:

Analog output

Additional $\leq \pm 0.01mA$

Temperature effect

Transmitter

$\leq \pm 0.08\%$ of reading/ $10^\circ C$

Analog output – Additional

$\leq \pm 0.08\%$ of reading/ $10^\circ C$

Power supply variation

Negligible

Pressure effect

Pipe conditions

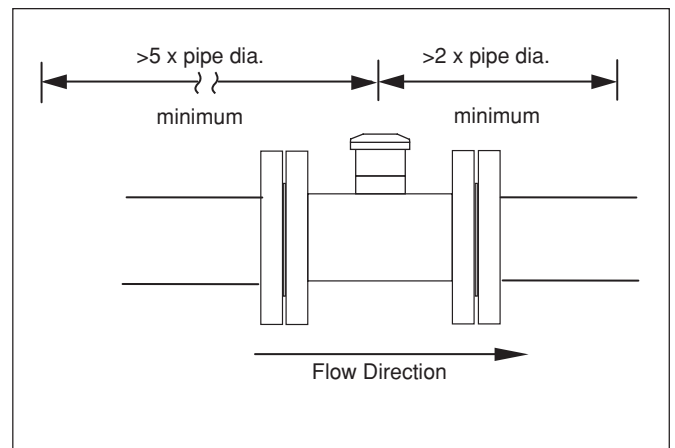

Pressure Loss

At Meter Maximum Flow	0.3 bar
At 50% of Meter Maximum Flow	0.075 bar

...Specification – Sensor

Wetted Materials

Screw End Meters

Brass, PPS and stainless steel 316L electrodes.

Flanged Meters

Lining

15 to 25mm – PPS

40 to 80mm – POMC

100 to 600mm – Elastomer (UKWFBS listed)

Electrodes – Stainless steel 316

Pressure Limitations

As flange rating

Screw end meters – 50 bar

Conductivity

$>5\mu\text{S cm}^{-1}$

Transmitter/Sensor Separation

$<100\text{m}$ (328 ft)

Power consumption

$<20\text{VA}$

Environmental Protection (when installed, remote sensor only)

Rating: IP68/NEMA 6P to 10m (33 ft) depth

Buriable: To 5m (16 ft) depth

End Connections

Sizes 25mm (1 in.) male screw thread:

15mm – G $\frac{3}{4}$ in. B $\frac{3}{4}$ in. NPSM

20mm – G 1 in B 1 in NPSM

25mm – G $1\frac{1}{4}$ in. B $1\frac{1}{4}$ in. NPSM

Sizes 40mm (1 $\frac{1}{2}$ in.) flanged to mate with:

ANSI B16-5 Class 150 (300mm only)

BS4504/IS07005 – PN16, PN10

AS4087/14

AS2129 Table 'C' & 'D'

BS10/AS2129 Table 'D' & 'E'

JIS to B2210, 5k, 10k

Mounting

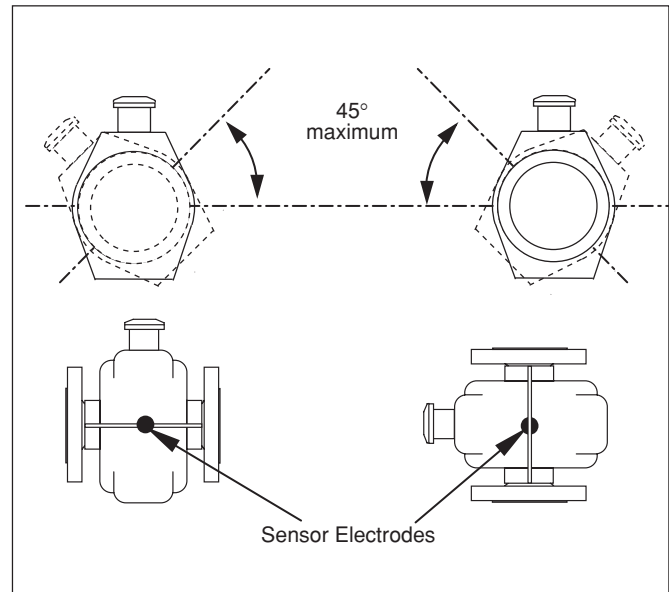

Temperature Ranges

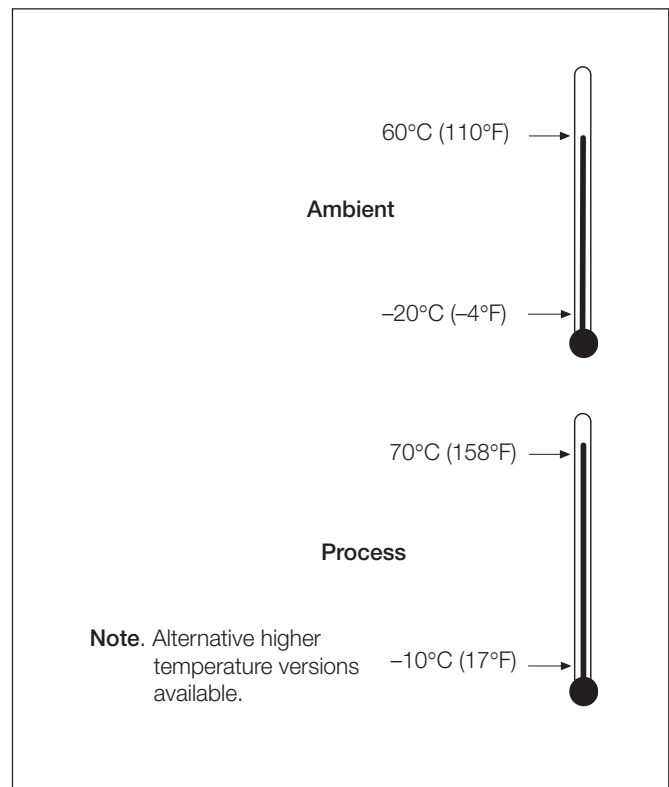

Sensor Sizes

15 to 25mm (1/2 to 1 in.) – Screw Ends

Meter Size		Dimensions* mm (in.)	Connection	Approx. Weight	
mm	in.	A		kg	lb
15	1/2	119 (4.7)	G 3/4 in. B or 3/4 in. NPSM	2.5	5
20	3/4	127 (5)	G 1 in. B or 1 in. NPSM	2.5	5
25	1	127 (5)	G 1 1/4 in. B or 1 1/4 in. NPSM	2.5	5

*Nominal dimensions

**Remote Transmitter
Mounting Option Dimensions**

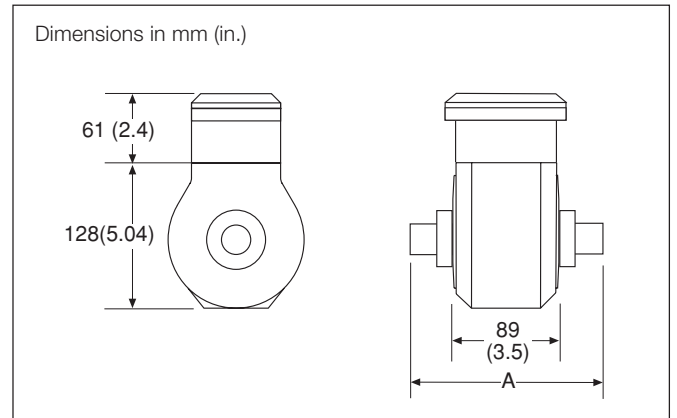

40 to 300mm (1 1/2 to 12 in.) – Flanged

Meter Size		Dimensions* mm (in.)		Approx. Weight		Max. End Loading	
mm	in.	A**	B	kg	lb	kN	lb
40	1 1/2	176 (7)	200 (7.9)	11	24	–	–
50	2	176 (7)	200 (7.9)	12	27	–	–
65	2 1/2	219 (8.6)	200 (7.9)	13	29	–	–
80	3	219 (8.6)	200 (7.9)	18	40	–	–
100	4	230.5 (9.8)	250 (9.8)	15	33	100	23000
150	6	281 (11.8)	300 (11.8)	31	68	190	43000
200	8	402 (15.8)	350 (13.8)	48	106	270	61000
250	10	440 (17.3)	450 (17.7)	75	165	390	89000
300	12	480 (18.9)	500 (19.7)	112	247	540	123000

*Nominal dimensions

**Dimensions are approximate and varying depending on flange type

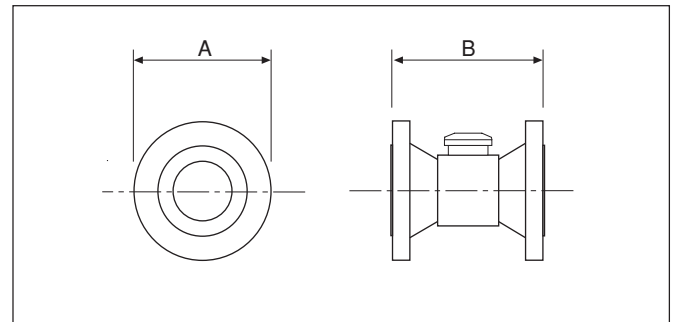

350 to 600mm (14 to 24 in.) – Flanged

Meter Size		Dimensions* mm (in.)			Approx. Weight	
mm	in.	A**	B	C	kg	lb
350	14	513 (20.2)	520 (20.5)	550 (21.7)	100	220
400	16	570 (22.4)	576 (22.7)	600 (23.6)	115	253
450	18	632 (24.9)	627 (24.7)	698 (27.5)	160	352
500	20	686 (27.0)	679 (26.7)	768 (30.2)	217	455
600	24	772 (30.4)	770 (30.3)	918 (36.1)	315	693

*Nominal dimensions

**Dimensions are approximate and varying depending on flange type

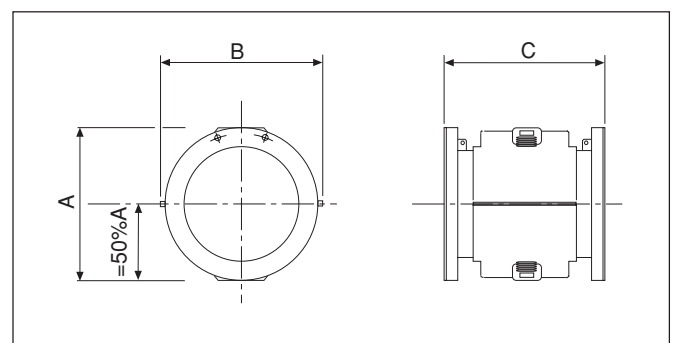

Note. See page 8 for Terminal Box and Transmitter dimensions.

Specification – Transmitter

Display (optional)

2-Line Display Version

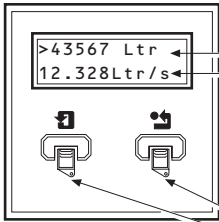

Forward flow total
Reverse flow total
Net flow total
Alarms
Flow Velocity in m/s or ft/s
Flow Rate % of Range

Flow rate

Magnetic switches for totalizer reset & to scroll through all parameters

Keypad Version

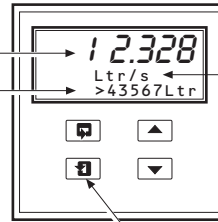

Alarm/
Flowrate units

Membrane keys for access, adjustment of all parameters, totalizer reset and to scroll through all parameters

Programming Options

- Local hand-held configurator
- Integral keypad
- HART

Fully configurable	A choice of engineering parameters in engineering units e.g. flowrate, flow units, all outputs etc.
Liquid sensing	Ensures units read zero on empty pipe
Interchangeability	Transmitter/sensor can be changed without affecting performance
Self diagnostics	Ensures transmitter and sensor integrity
Test mode	Powerful commissioning aid. Exercises all outputs and displays, even without a connected sensor
Language	English, French, German, Spanish, Italian, Dutch, plus others on application

Temperature Ranges

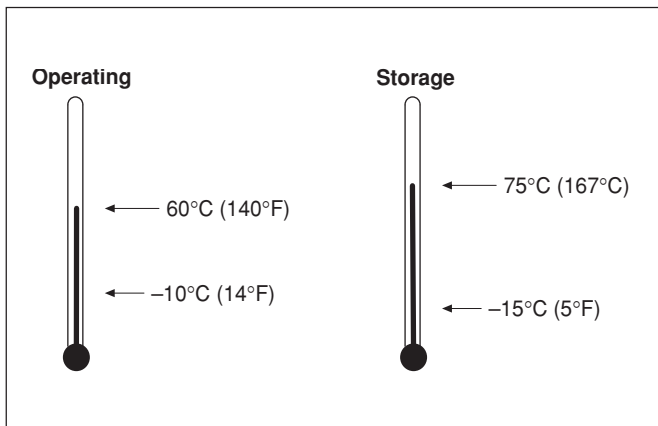

Power Supply *

Voltage Type	Voltage Range (V)	Frequency (Hz)	VA
AC	95 to 250 nominal	47 to 440	< 20
DC	11 to 40 maximum	–	< 20

*Power supply fully isolated

Environmental protection

IP65/NEMA4

EMC Specification

Conforms to –
EMC Directive 89/336/EEC to 10 V/m

Enclosure

Glass loaded polypropylene, polycarbonate window
UL VO rated

Electrical connections

20 mm glands, or accepts
1/2 in. NPT connections

Sensor Cable

ABB supplied standard and armored versions



Outputs/Inputs

Common

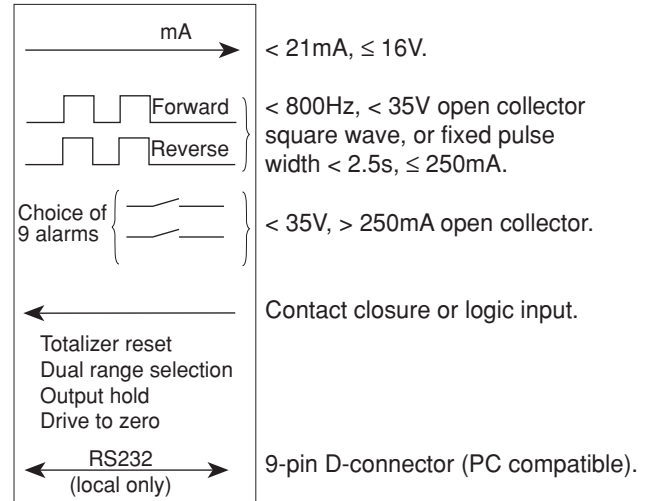

Optional (For Blind & 2-line display units)



Overall Dimensions

Transmitter – Remote Mounting

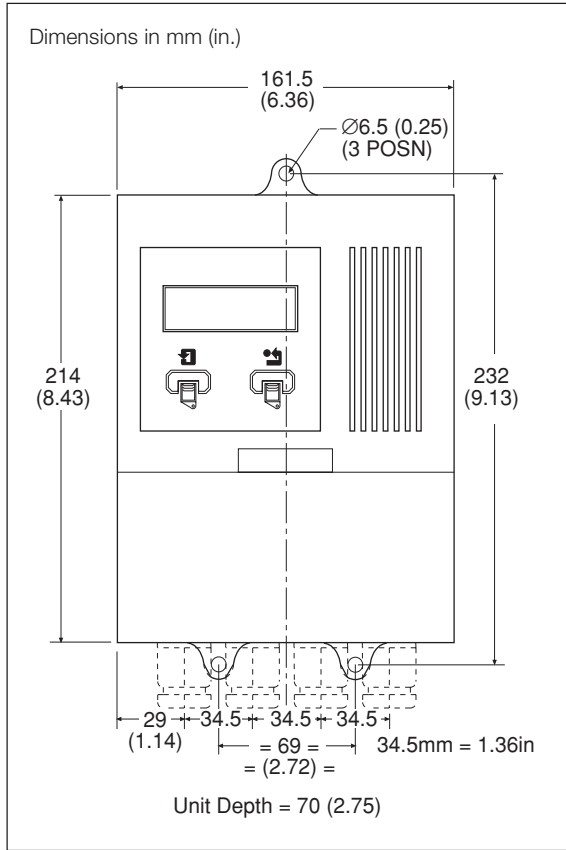

Transmitter – Integral (Mounted on Sensor)

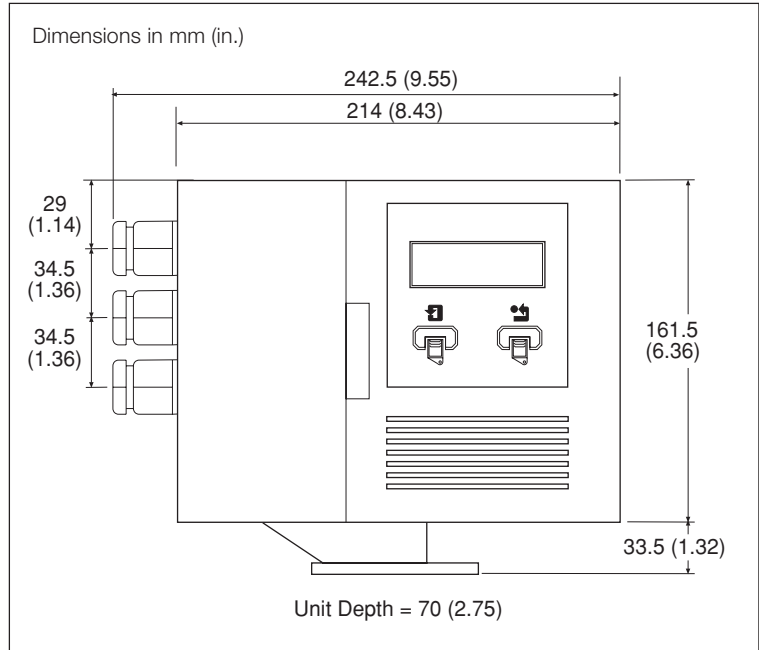

Terminal Box (Mounted on Sensor)

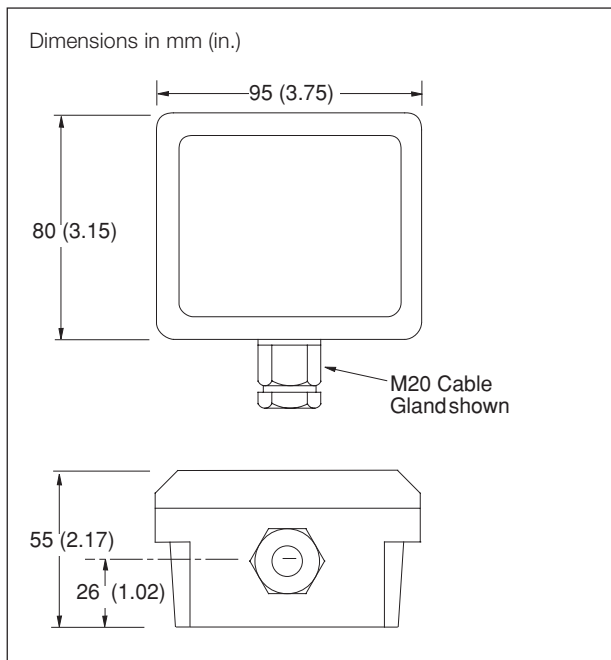

Electrical Connections

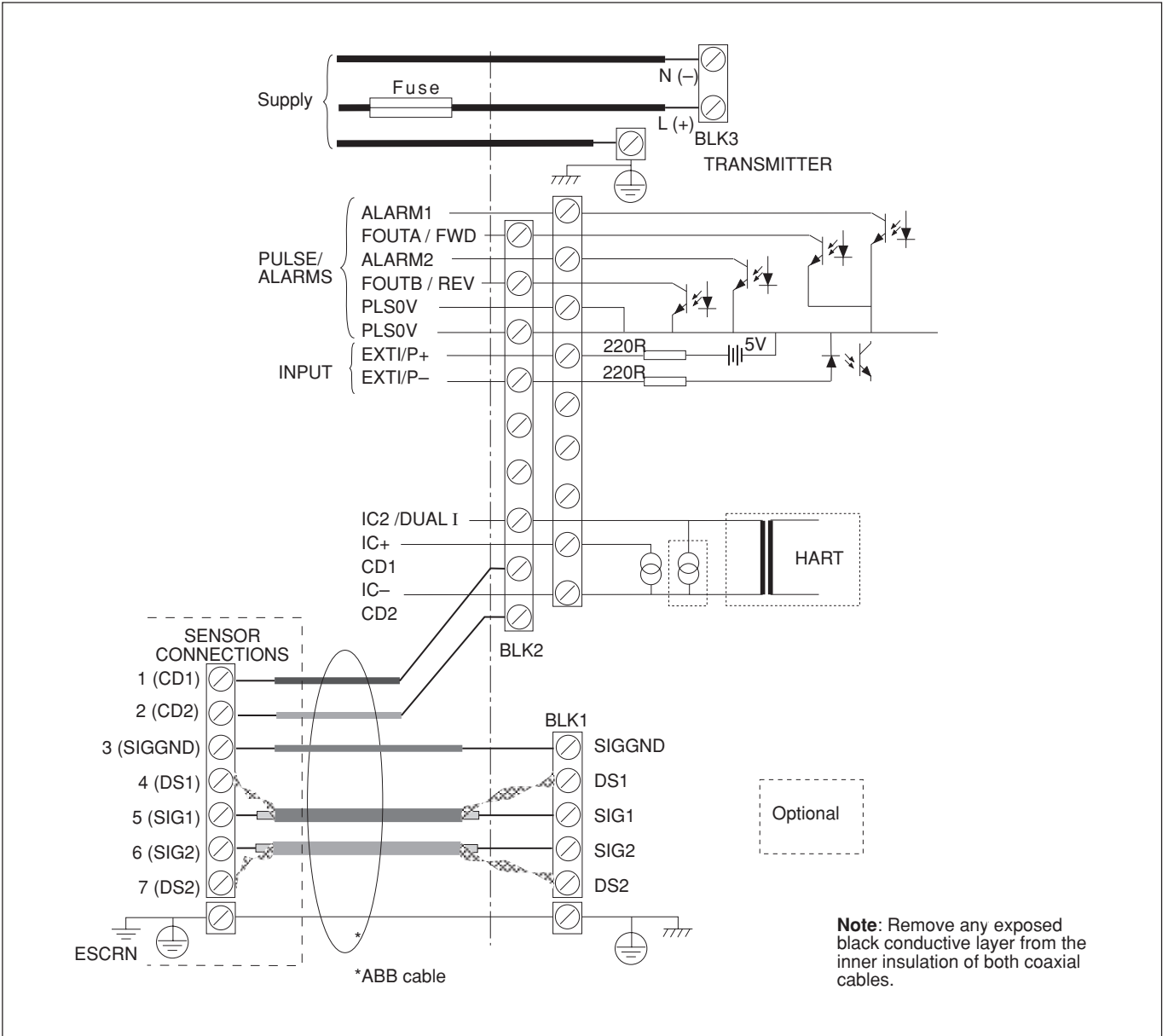

Ordering Information

				Main Code					Optional Code						
Electromagnetic Flowmeter				MM/G E	X	XXXX	X	X	X	X	X	X	X	0	X
Country															
	Default Flange	Cable Entry													
English	PN16	20mm	G												
French	PN16	20mm	F												
German	PN16	20mm	D												
Spanish	PN16	20mm	E												
Italian	PN16	20mm	I												
Dutch	PN16	20mm	H												
USA	ANSI.150	1/2 in. NPT	U												
Australia	AS4087/14	20mm	A												
Calibrated Bore															
mm	in.														
15	(5/8)			0015											
20	(3/4)			0020											
25	(1)			0025											
40	(1 1/2)			0040											
50	(2)			0050											
65	(2 1/2)			0065											
80	(3)			0080											
100	(4)			0100											
150	(6)			0150											
200	(8)			0200											
250	(10)			0250											
300	(12)			0300											
350	(14)			0350											
400	(16)			0400											
450	(18)			0450											
500	(20)			0500											
600	(24)			0600											
Sensor/Electronic Display unit															
Sensor and Integral electronics (DN40 to DN300 only)															
Sensor and Remote Electronics															
Power Supply															
AC															
DC															
Transmitter Display Options															
2-Line Display															
Blind															
3-Line Display with Key Pad + earth ring for ≥DN100															
2-Line Display with HART + earth ring for ≥DN100															
Cable Length (Supplied loose) – Remote Electronic Unit only															
Not required on sensor-mounted transmitter															
0m														0	
10m														1	
20m														2	
30m														3	
40m														4	
50m														5	
60m														6	
70m														7	
80m														8	
100m														A	

See next page

	Main Code							Optional Code					
	MM/G E	X	XXXX	X	X	X	X	X	X	X	0	X	
Labelling/Construction													
ABB UK								0					
ABB USA								1					
Flange Style/End Connections													
Standard (see country digit on previous page)									0				
AS4087 Class 14 Flanges (40 to 600mm only)									A				
AS2129 Table C Flanges (40 to 600mm only)									C				
AS2129 Table D Flanges (40 to 600mm only)									D				
ISO 7005 PN10 Flanged (40 to 600mm only)									M				
ISO 7005 PN16 Flanged (40 to 600mm only)									E				
ANSI B 16.5 Class 150 Flanged (40 to 600mm only)									U				
BS10 Table D Flanged (40 to 600mm only)									F				
BS10 Table E Flanged (40 to 600mm only)									G				
JIS B2210, 5 k Flanged (40 to 600mm only)									L				
JIS B2210, 10 k Flanged (40 to 600mm only)									J				
Parallel thread ISO 228-1 Class B (15 to 25mm only)									T				
Thread to NPSM (3/4 to 1 1/4 in. only)									Y				
Cable Entries													
Standard (see country digit). Cable not fitted/potted										0			
Standard (see country digit). Cable fitted/potted										A			
20mm Plastic Glands. Cable not fitted/potted										1			
20mm Plastic Glands. Cable fitted/potted										B			
1/2 in. NPT (USA Only). Cable not fitted/potted										3			
20mm armoured. Cable not fitted/potted										2			
20mm armoured. Cable fitted/potted										C			
Fixed Digits											0		
Calibration													
1 Point – no pressure test												0	
1 Point – with pressure test												1	
3 Point – no pressure test												2	
3 Point –with pressure test												3	
NAMAS + pressure test (≥250mm only)												4	
3 Point – no pressure test, CalMaster fingerprint												5	
3 Point – with pressure test, CalMaster fingerprint												6	

ABB has Sales & Customer Support
expertise in over 100 countries worldwide

www.abb.com

The Company's policy is one of continuous product
improvement and the right is reserved to modify the
information contained herein without notice.

Printed in UK (11.04)

© ABB 2004



ABB Ltd.
Oldends Lane, Stonehouse
Gloucestershire
GL10 3TA
UK
Tel: +44 (0)1453 826661
Fax: +44 (0)1453 829671

ABB Inc.
125 E. County Line Road
Warminster
PA 18974
USA
Tel: +1 215 674 6000
Fax: +1 215 674 7183