

- **One or two pen continuous line 100mm recorder**
  - universal input for thermocouple, RTD, mV, mA and V
- **Clear, 5-digit LED display**
  - high visibility, wide viewing angle
- **Two (5A) alarm relays as standard**
  - allocated to individual channels or common to both
- **Isolated analog retransmission**
  - easy connection to management system
- **Two digital inputs**
  - chart start/stop, change chart speed or remote alarm acknowledge
- **Configuration from front fascia or via PC**
  - simple configuration setup and storage procedure
- **Transmitter power supply**
  - power each loop from the standard unit, no extras needed
- **IP65/NEMA3 protection**
  - reliability in the harshest environments



**CR100**  
– combination of a high resolution  
process indicator and a compact  
chart recorder

**CR100**

The CR100 is a one or two pen continuous-line 100mm strip chart recorder with a number of features included as standard:

- Two alarm relays
- Isolated analog retransmission
- Two digital inputs
- Transmitter power supply.

These inbuilt features make the CR100 an extremely versatile chart recorder.

It has a bright, 5-digit LED display giving clear indication of the process. Configuration using the front keys is very easy. The CR100 can also be configured using the PC Configuration software increasing the flexibility and reducing setup time.

With a IP65/NEMA3 front fascia the CR100 is suitable for use in harsh industrial environments.

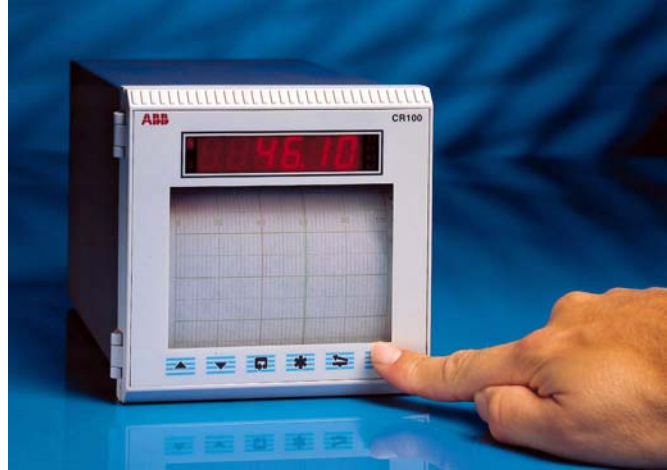

**Process Connections**

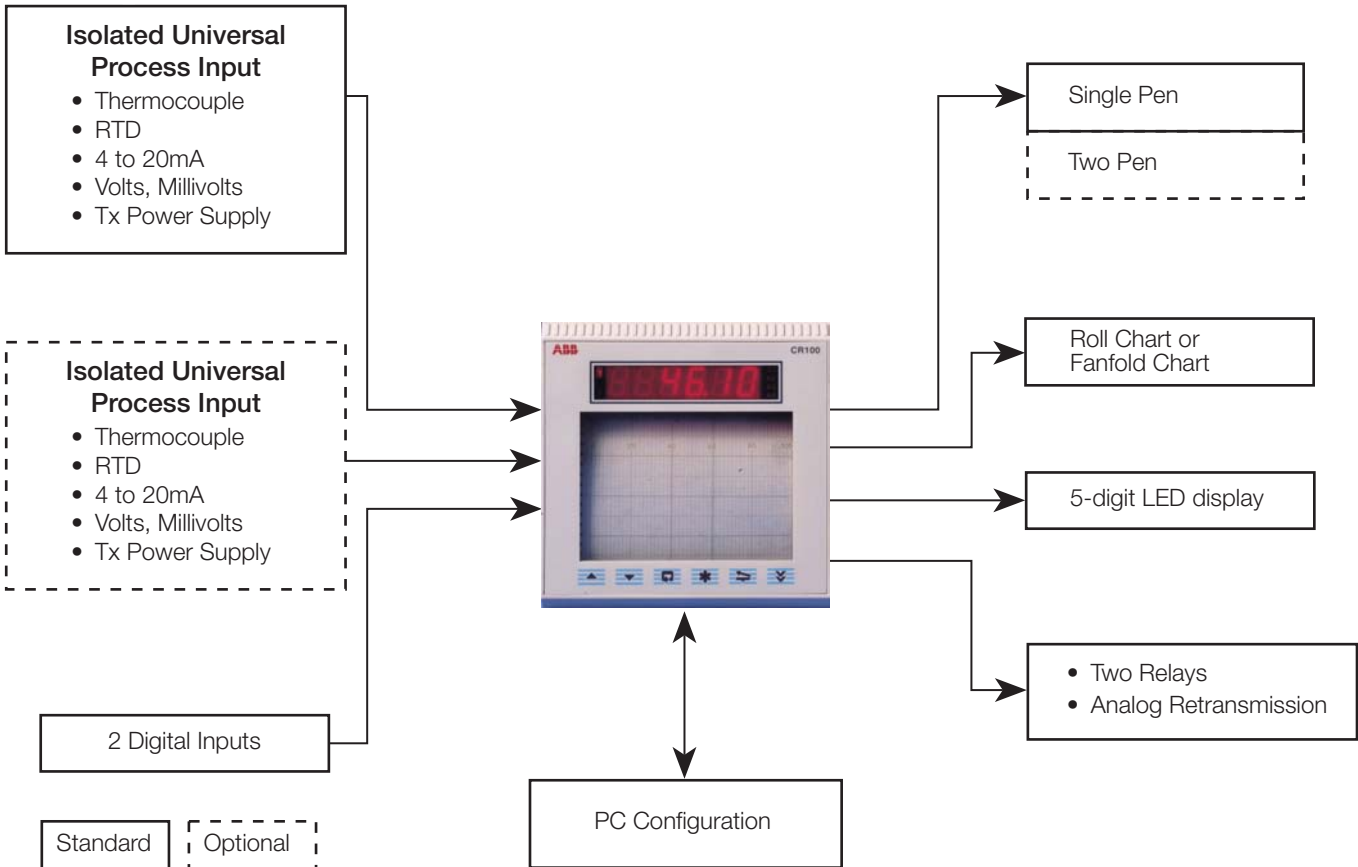

### Clear Display and Simple Controls

Process values and alarm messages are shown on the high-resolution 5-digit LED display which has been designed for maximum visibility. On the two-pen version the display toggles between input one and input two.

Beneath the display are 6 keys (increment, decrement, scroll, multifunction, pen lift and chart speed selection) that are used to operate and configure the recorder.

The instrument is equipped with four user-defined alarms, each with its own LED which is lit when an alarm condition exists.

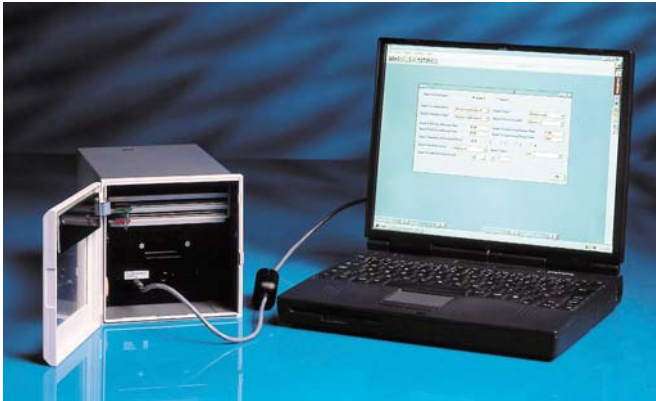

### Extras Built-in as Standard

To meet the majority of process needs, two relays are included in the standard build. These can be allocated as one per channel, both on one channel or common to both channels.

Further flexibility is provided by an analog retransmission signal and two digital inputs. The digital inputs can be used for remote acknowledgement of alarms, starting and stopping the chart or for changing the chart speed.

All this as standard makes the CR100 an extremely versatile recorder.

### Isolated Universal Analog Inputs

Both of the analog inputs are universal, galvanically isolated and accept direct connection from all standard thermocouple, RTD, mA, mV and voltage sources.

Using the PC Configuration software, non-standard ranges as low as 5mV are also possible.

The recorder also has a 2-wire transmitter power supply suitable for powering each loop.

## Easy Setup

The CR100 can be configured in one of two ways:

### Front face keys

The front face keys are used to configure the instrument via a security code protected configuration menu.

### PC Configurator

The standard equipment PC configurator port is used to connect a PC equipped with the Windows™-based PC Configurator software making setup a point-and-click operation. Settings can also be saved on the PC and copied to other recorders making setup of multiple instruments quick and simple.

## Rugged Enclosure Design

The case has been designed to withstand operation in harsh industrial environments with IP65/NEMA3 front face protection as standard. This makes the instrument ideal for use in food applications and hosedown areas.

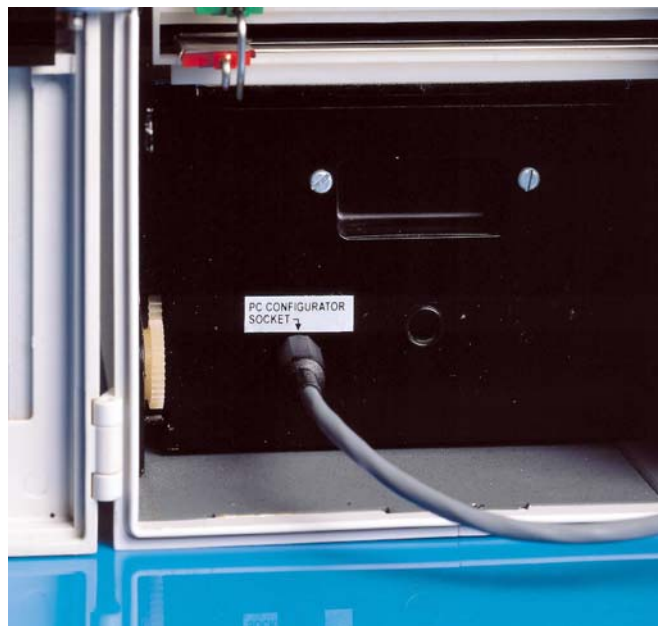

## Applications

### Temperature Monitoring

The compact design of the CR100 makes it ideal as a local temperature monitor and alarm.

Inbuilt CJ compensation enables the direct connection of all standard thermocouples. For precision measurement Pt100 resistance thermometers can be connected directly via the universal input, thus ensuring low installation costs.

The clear LED display provides highly visible indication and numbered alarm LEDs provide instant process status verification.

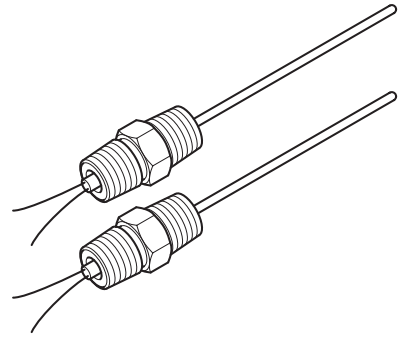

### Environmental/Laboratory Monitoring

The unbroken line on the chart provided by the CR100 is ideal for continuous gas or liquid environmental applications.

Other uses include batch monitoring of laboratory tests, or test chambers, to verify the test results and the provision of alarm signals to indicate if a test exceeds preset limits.

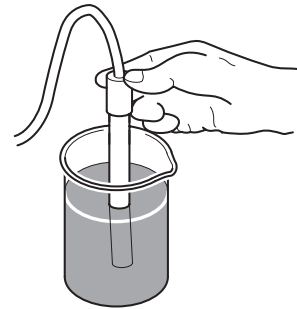

### Discharge Monitoring

With universal inputs the CR100 provides the opportunity for local monitoring and alarms for the measurement of parameters such as level, flow and pH.

The retransmission also provides the ability to retransmit this signal to a process monitor so readings can be integrated into a plant data acquisition scheme.

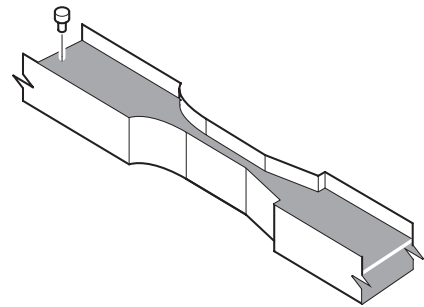

### Indicating Recorder

Ideal for small units or operator panels providing clear, high resolution digital indication of process variables.

The cost-effective price of the CR100 allows individual indication, with sensitivity down to  $10\mu\text{V}$ , or  $0.2^\circ\text{C}$  ( $0.11^\circ\text{F}$ ), and a secure hard copy record for traceability of the process.

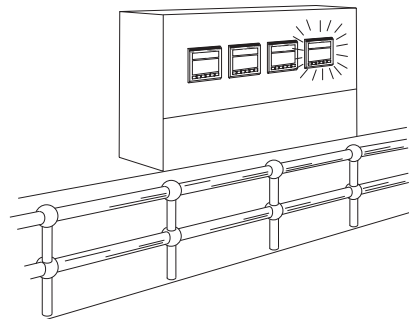

## Specification

### Summary

1 or 2 continuous lines  
 100mm wide roll or fanfold chart  
 Fully user-programmable  
 IP65/NEMA3 protection

## Recording

### Measuring channels

1 or 2

### Colors

Single continuous line, Red

Two continuous lines, Pen 1 – Red, Pen 2 – Green

### Chart

7.5 m fanfold or 15m roll

Quick-load cassette

Standard chart graduation 50 divisions

### Chart speed

Configurable in 1mm steps between 1mm and 1500mm/hr

Logic or switch selectable at two configured speeds

### Pen response time

4s, 10 to 90%, typical

## Operation

### Display

High intensity 5-digit LED display (14mm high)

### Configuration

User-defined via front panel or Windows-based PC configurator

### Alarms

Number 4 user-defined

Types High/Low process  
 High/Low latch

Hysteresis Programmable level

## Accuracy

### Pen

Resolution 0.2% of span

### Display

Display range –9999 to +99999

Display resolution  $\pm 1$  digit

## Digital Inputs

Number 2

Type Volt-free contacts

Minimum pulse 250ms

## Outputs

### Retransmission

Analog configuration in the range of 4 to 20mA

Max. load 15V (750 $\Omega$  at 20mA)

Accuracy  $\leq 0.25\%$  of span

Isolation 500V DC from inputs

Assignable to any one analog input

### Relay Outputs

2 relays (SPDT) 5A at 115/230V AC  
 Assignable to alarms

## Physical

### Size

144mm (5.67 in.) x 144mm (5.67 in.)  
 x 230mm (9.05 in.) depth behind panel

### Weight

3.3kg (7 lbs) approx.

### Panel cut-out

138mm (5.43 in.) x 138mm (5.43 in.)

### Case material

Sheet steel case, stove enamel painted

### Door material

Glass-filled polycarbonate

### Window material

Polycarbonate

## Electrical

### Power supply

85 to 265V 50/60Hz

### Power consumption

36W max.

### Electrical safety

EN61010-1

CE marked instruments meet EU regulations

CSA (optional)

### Electrical connections

Screw terminals

## Environmental

### Operating limits

0 to 50°C (32 to 122°F)  
95% RH non-condensing  
80% RH for chart

### Temperature stability

0.02% of reading or 2μV/°C whichever is the greater

### Protection

Front face IP65 NEMA3  
Rear of instrument IP20

### Line interruption

<80ms loss, no effect  
>80ms loss, auto reset and restart

---

## EMC

### Emissions and Immunity

Meets requirements of IEC 61326 for an Industrial Environment

### Design and manufacturing standards

Designed to meet CSA requirements  
CE mark

## Analog Inputs

### Number

1 or 2 isolated analog inputs

### Input sampling rate

250ms

### Input Type

Universally configurable to provide:

Thermocouple (THC)\*  
Resistance thermometer (RTD)  
Millivolt  
Current  
DC voltage

\*2<sup>nd</sup> input can be THC, but only if 1<sup>st</sup> input also THC

### Linearizer functions

Programmable for: Square root  
THC types B, E, J, K, N, R, S, T or Pt100

Filter time Adjustable up to 60s

### Broken sensor protection

Upscale drive on THC and RTD  
Downscale drive on mA and voltage

### Cold junction compensation (CJC)

Automatic CJC incorporated as standard  
Accuracy <0.05% °C/°C change in ambient

### Input impedance

mA 100Ω  
mV, V >10MΩ

### Transmitter power supplies

Two isolated supplies 25mA max. each

### Input isolation

Analog channel-to-channel isolation 500V DC  
Input to ground 700V DC  
Common mode >120dB at 50/60Hz with  
300Ω imbalance resistance  
Series mode >60dB at 50/60Hz

### 3-lead RTD

Max. lead resistance 10Ω

## ...Specification

### Standard Analog Input Ranges

Thermocouple	Maximum Range °C	Maximum Range °F	Accuracy (% of reading)*
B	-18 to 1800	0 to 3270	0.25% or ±2°C (above 200°C)
E	-100 to 900	-140 to 1650	0.25% or ±0.5°C
J	-100 to 900	-140 to 1650	0.25% or ±0.5°C
K	-100 to 1300	-140 to 2350	0.25% or ±0.5°C
N	-200 to 1300	-325 to 2350	0.25% or ±0.5°C
R	-18 to 1700	0 to 3000	0.25% or ±1.0°C (above 300°C)
S	-18 to 1700	0 to 3000	0.25% or ±0.5°C (above 200°C)
T	-250 to 300	-400 to 550	0.25% or ±0.5°C

\* Performance accuracy is not guaranteed below 400°C (752°F) for B, R and S thermocouples

Min. span below zero Type T 70°C (126°F)  
Type N 105°C (189°F)

THC standards DIN 43710 IEC 584

RTD	Maximum Range °C	Maximum Range °F	Accuracy (% of reading)**
Pt100	-200 to 600	-325 to 1100	0.25% or ±0.5°C

\*\* RTD, 3-wire platinum, 100Ω per DIN43760 standard (IEC751), with range of 0 to 400Ω

Linear Inputs	Range	Accuracy (% of reading)
Milliamps	0 to 20	0.25% or ±2μA
Milliamps	4 to 20	0.25% or ±2μA
Volts	0 to 5	0.25% or ±2mV
Volts	1 to 5	0.25% or ±2mV
Millivolts	0 to 50	0.25% or ±20μV

Square Root Input	Range	Accuracy (% of reading)***
Milliamps	4 to 20	0.25% or ±2μA

\*\*\* Below input of 4.64mA (20% flow) the input is linear

### Overall Dimensions

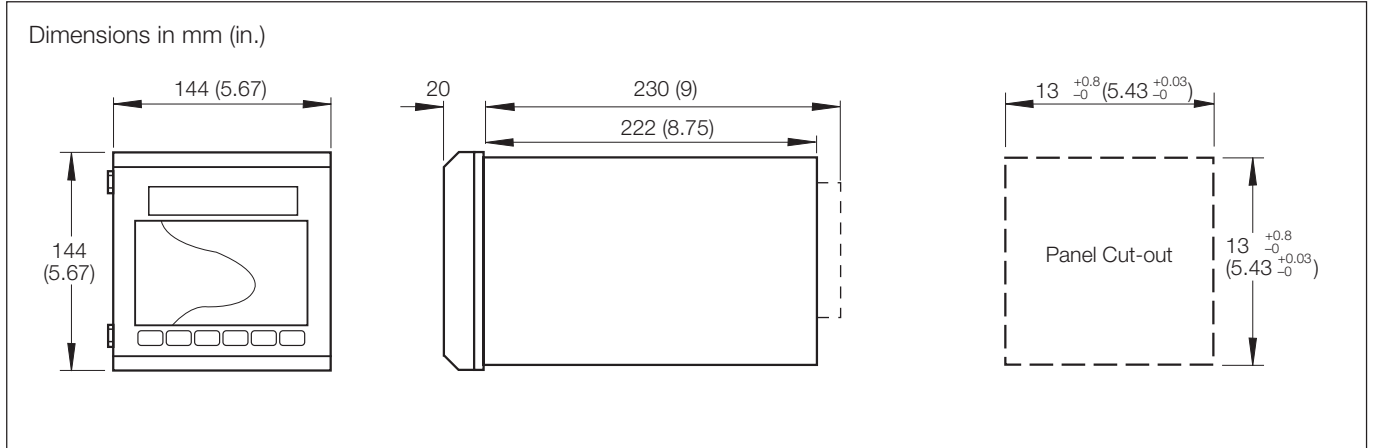

### Electrical Connections

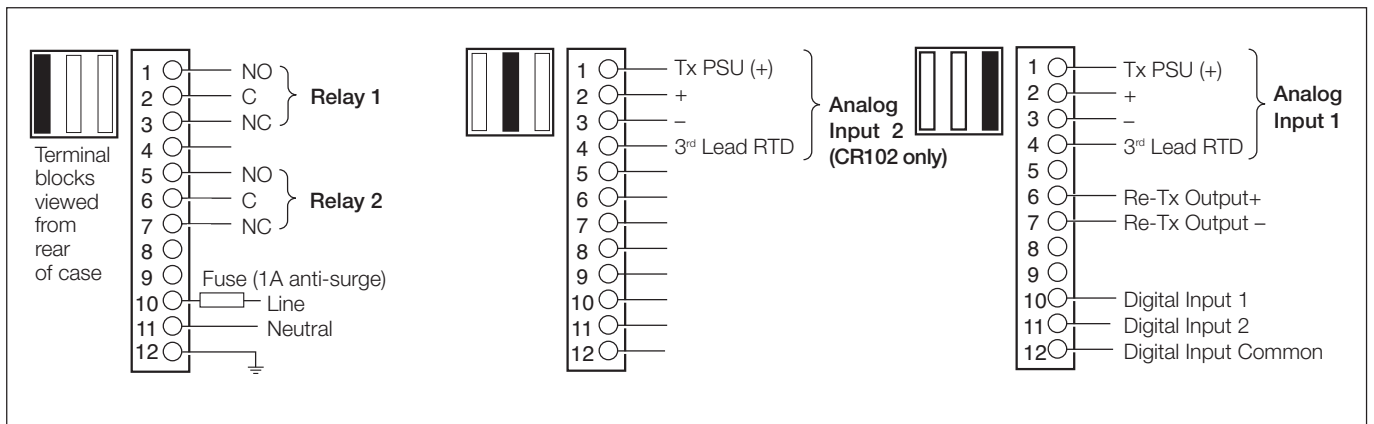

**Ordering Information**

CR100 100mm Process Indicator Recorder	CR10	X/	X	X	X	X/	XXXX
<b>Number of Pens</b>							
Single pen		1					
Two pens		2					
<b>Build</b>							
ABB Standard			B				
CSA approval (pending)			C				
<b>Door</b>							
Without lock				0			
<b>Chart Drive</b>							
Roll chart					1		
Fan-fold chart					2		
<b>Power Supply</b>							
85 to 265V AC						1	
<b>Programming/Special Features</b>							
Configured to factory standard							STD
Configured to customer requirements							CUS
Special features							SPXX

**Accessories**

PC Configurator kit (part no. C100/0700)

**Standard Chart Selection**

Range	Roll Chart Part No.		Fanfold Chart Part No.	
	International	North America	International	North America
-50/+50	P100L/7477G	KPC100-1110	P100L/7477X	KPC100-8042
0/14	P100L/17463G	KPC100-1047	P100L/17463X	KPC100-8032
0/50	P100L/7401G	KPC100-1032	P100L/7401X	-
0/100*	P100L/7400G	KPC100-1037	P100L/7400X	KPC100-8034
0/150	P100L/7414G	KPC100-1039	P100L/7414X	KPC100-8050
0/200	P100L/7420G	KPC100-1040	P100L/7420X	KPC100-8051
0/500	P100L/7010G	KPC100-1043	P100L/7010X	KPC100-8058
0/800	P100L/17446G	KPC100-1045	P100L/17446X	KPC100-8064
0/1000	P100L/7476G	KPC100-1072	P100L/7476X	KPC100-8037

\*Supplied as standard

**Note.** Other ranges may be available on request.

**Licensing, Trademarks and Copyrights**

MS Windows™ is a trademark of Microsoft Corporation  
Modbus™ is a trademark of Modicon, Inc.

**ABB** has Sales & Customer Support expertise in over 100 countries worldwide

[www.abb.com](http://www.abb.com)

The Company's policy is one of continuous product improvement and the right is reserved to modify the information contained herein without notice.

Printed in UK (05.05)

© ABB 2005



**ABB Limited**

Howard Road, St Neots  
Cambridgeshire  
PE19 8EU  
UK  
Tel: +44 (0)1480 475321  
Fax: +44 (0)1480 217948

**ABB Inc.**

125 E. County Line Road  
Warminster  
PA 18974  
USA  
Tel: +1 215 674 6000  
Fax: +1 215 674 7183