

- **Bright and clear display**
 - high contrast, thin film transistor (TFT) color screen

- **Secure data recording**
 - 8Mb internal Flash memory for 12 recording channels and logs
 - no battery back-up required

- **Robust and convenient archive storage**
 - low cost, high reliability, SmartMedia and Compact Flash options
 - adapters for PCs

- **Intuitive user interface**
 - dedicated operator keys and touchscreen configuration

- **Unsurpassed environmental protection**
 - hosedown to IP66 and NEMA4X standards

- **Flexibility to meet your application needs**
 - 6 or 12 universal inputs, I/O modules, math and communications

- **10BaseT Ethernet communications**
 - remote monitoring/access
 - email notification of alarms and status reports



**Raising the Standards
of Data Storage**

SM2000

The SM2000 is a state-of-the-art solution to recording and data storage. It provides 12 recording channels and up to 12 universal analog inputs which can be viewed in a variety of display formats: chart, bargraph, digital indicator and process summary. Historical logs are provided for recording alarms, operator and system events and totalizer values.

A high quality, 14cm (5.7 in.), TFT display and analog, resistive touchscreen provide a clear and intuitive user interface.

The SM2000 has an onboard Flash memory capacity of 8Mb providing storage of up to 2.9 million samples. A choice of removable storage devices are available: SmartMedia or Compact Flash for installations in environments reaching up to 50°C (122°F).

Application areas include:

- Water treatment plants
- Cold storage
- Stack gas monitoring
- Environmental monitoring
- Autoclaves
- Food, Dairy & Beverage processing
- Furnaces
- Heat treatment
- Pulp & Paper

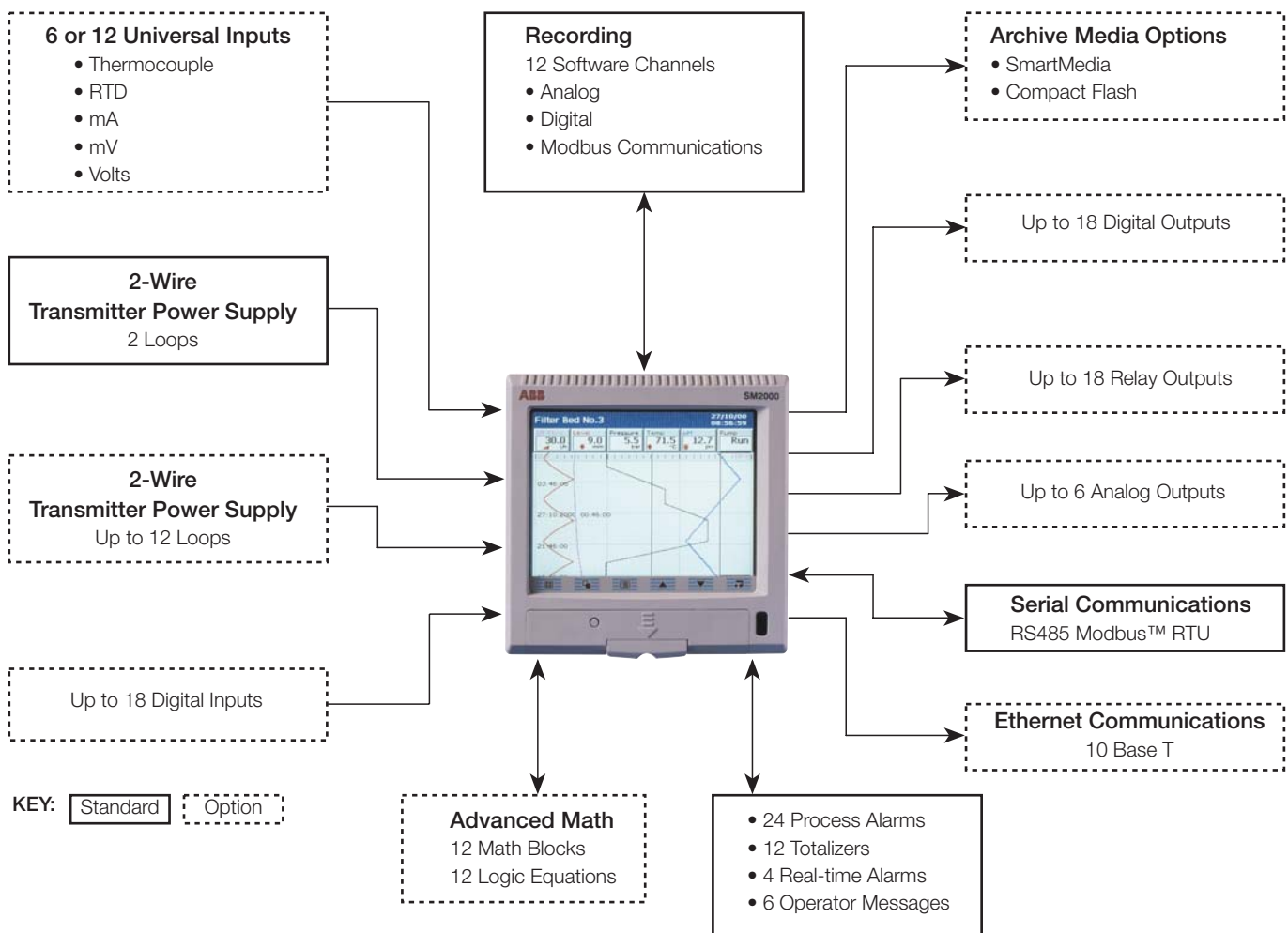

Guaranteed Data Integrity

- The use of Flash memory technology ensures that the SM2000 is not reliant on batteries to preserve stored data during a power failure.
- In the internal memory, data is stored in small blocks with each block containing a checksum to ensure the integrity of that data.
- An enhanced error detection/correction code is built-in to the internal Flash memory, ensuring safe storage of your process data.
- 8 Mb of internal Flash memory is provided for buffering of data. The complete 8Mb of data can be reviewed on the display of the SM2000. Once this memory is full it automatically wraps-around and overwrites the oldest data, ensuring that the latest process data is always captured.
- 12 recording channels are provided as standard which can be used to record any analog, digital or communications (via Modbus) signal. Each channel can be recorded at their own primary or secondary sample rate. This allows detailed information to be stored under specific process conditions e.g. critical process states or alarm conditions. Alternatively, for simple applications one sample rate can be applied to all channels. Through the use of pre-storage filters it is possible to record the average, max./min. or instantaneous value of any analog data.

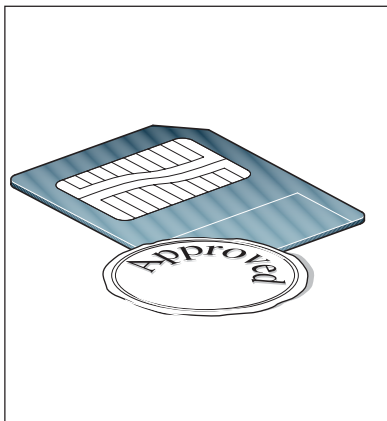
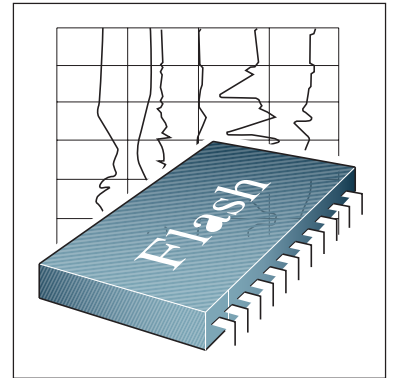

Industrial Standard, Robust, Archive Storage

- Either SmartMedia or Compact Flash memory card options can be fitted to the SM2000 for archiving purposes. Process data can be archived to the removable media in either of two configurable formats: comma-separated variable or binary encoded. In addition to the analog/digital recording channels, the alarm event, totalizer (if fitted) and audit logs can also be archived to the removable media.
- The solid-state nature of SmartMedia and Compact Flash devices ensures that the SM2000 can truly operate in ambient temperatures up to 50°C (122°F) whereas traditional electro-mechanical floppy disk drives can operate only in temperatures up to 40°C (104°F).
- Every write to the archive storage media is verified to ensure the integrity of the data.
- Security of all process data stored to the memory card is always assured. Files stored in comma-separated variable format are attributed with an Encrypted Digital Signature and files stored in binary format are encoded securely with inbuilt integrity checks. Both formats of data storage are compliant with FDA standard 21 CFR Part II.

Security

- A Media door lock is fitted as standard to prevent unauthorized access to the removable media.
- Two security modes are available. In the first, a tamper-proof seal can be fitted to the front of the instrument to meet the requirements of regulatory bodies. In this mode, the configuration of the recorder can be altered only by first changing the position of an internal switch. To accomplish this the unit needs to be removed from its case, breaking the seal. In the second mode, the configuration can be protected by the use of four, individual, user-specific passwords.

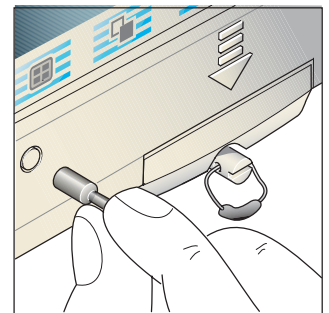

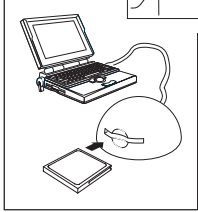
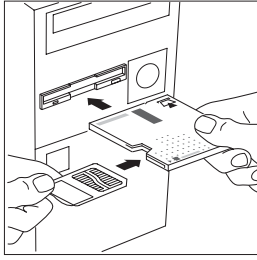

PC Interface for Archive Storage Media

Through the use of PC adapters, SmartMedia and Compact Flash both provide the advantages of very robust, solid-state storage with the convenience of use previously found only with floppy disks.

- A SmartMedia-to-floppy disk drive adapter enables SmartMedia cards to be read directly by the existing floppy disk drive on your computer.
- Archives stored on Compact Flash and SmartMedia can be accessed via a reader which plugs into the parallel or USB port of a desk/lap-top computer.

Low Cost of Ownership

The large capacity of the storage media used on the SM2000 ensures that the requirement for operator intervention to transfer the data to a PC on a regular basis is greatly reduced. Older floppy disk technology, used by many other manufacturers of graphical recorders, limits storage capability significantly, sometimes to levels below the ability of a traditional paper recorder.

See below for an example of how memory storage times vary depending on the media device. The example shows the recording duration for a 6-channel recorder with a sample time of 10s. Also included in the example is how these storage times compare with a traditional paper recorder.

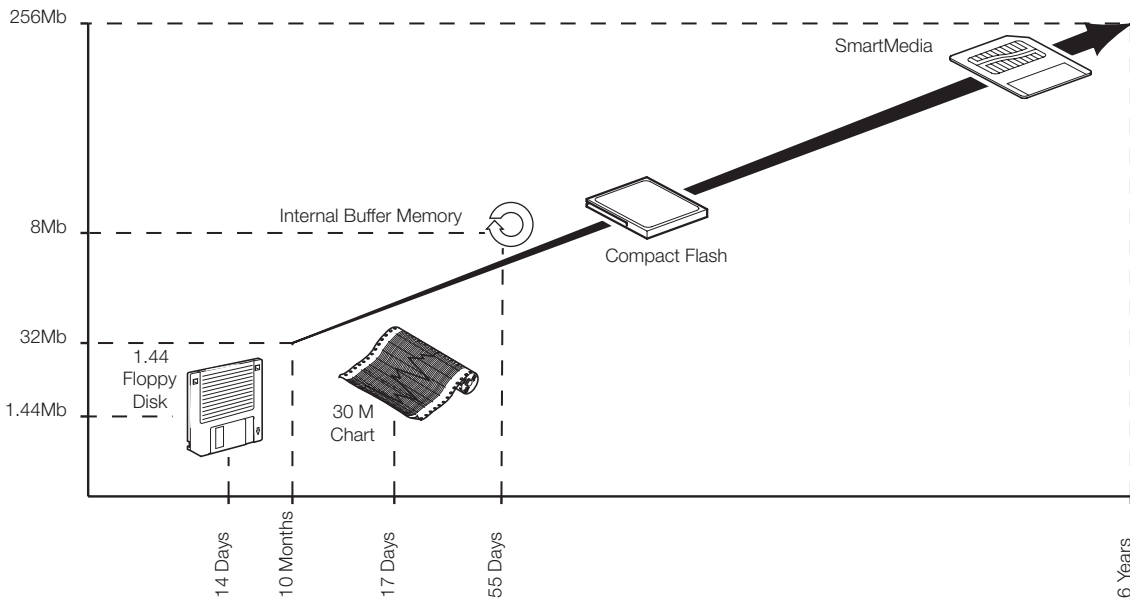

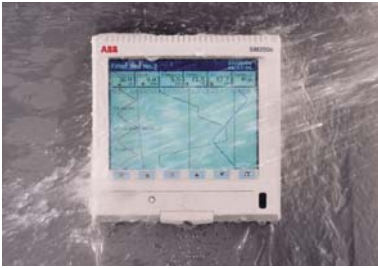

Unsurpassed Environmental Protection

Unique to this type of product, the SM2000 has unrivalled protection ratings of IP66 and NEMA4X and includes a fully-sealed, lockable media door. This enables the SM2000 to be installed, without additional protection, in applications that require frequent hosedown. With industrial standard noise emission and immunity protection, the SM2000 operates effectively in high electrical-noise environments.

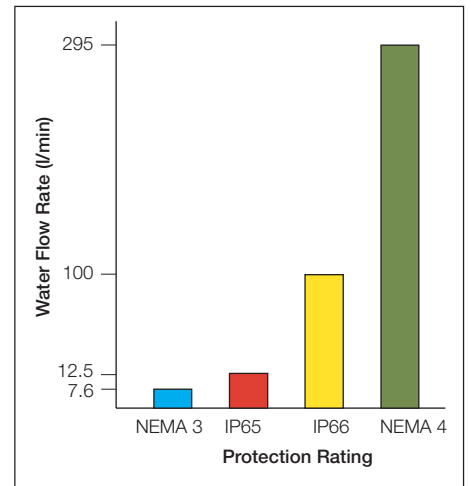

Intuitive User Interface

The diagram illustrates the user interface for 'Process Group 1'. At the top, a title bar displays the group name, a global alarm icon, status icons, and the current date and time (05/09/00 16:56:06). Below this, a row of six data channels is shown: Temp 1 (58.3 °C), Pressure (3.37 bar), In Flow (49.9 Gal/hr), Volume (66.6 Litres), Temp 2 (421.5 °F), and Valve (Open). Each channel has a corresponding trend chart below it. The charts show historical data with a 'Newest Data' point at the top and 'Oldest Data' at the bottom. The interface also displays alarm events, such as '16:55:37 High temperature' and '16:53:36 High temperature', and operator messages like '16:54:47 Batch Start'. A legend at the bottom defines the navigation keys: Group Key, View Key, Menu Key, Up/Down Arrow, and Enter.

Key	Description
Group Key	Selects between process groups and historical logs
View Key	Selects between enabled views for the selected process groups/logs
Menu Key	Displays a pop-up menu for operator selections
Up/Down Arrow	Used to navigate pop-up menus and review data in historical review mode
Enter	Used for confirming menu selections

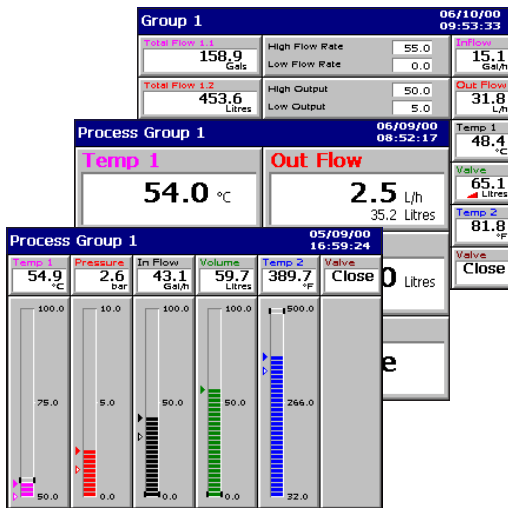

Operator Views

In addition to the standard chart view, a number of other operator views are available:

Process View

Provides an at-a-glance summary of each channel including alarm, totalizer and statistical (max./min.) information.

Digital Indicator View

Process value, engineering units, channel tag, associated totalizer (if applicable), and alarm status are all shown. Auto-sizing always ensures the clearest possible display.

Bargraph View

Horizontal or vertical format which includes min./max. and alarm trip point markers.

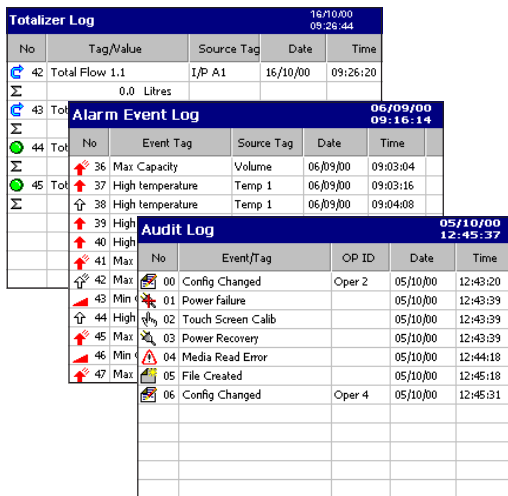

Historical Logs

Providing functions unavailable in paper based recorders, three historical logs ensure complete validity of the recorder and its data. Any or all of these logs can be exported to the removable media:

Totalizer Log

Independent log intervals for each channel, enabling total, average, maximum and minimum readings to be time and date stamped.

Alarm Event Log

Complete display of all acknowledged and unacknowledged alarms, alarm state changes and operator messages.

Audit Log

Displays time, date and ID stamped system data including configuration, calibration changes, system errors and operation actions. This provides comprehensive evidence of the integrity, validity and traceability of the SM2000 and its measured data.

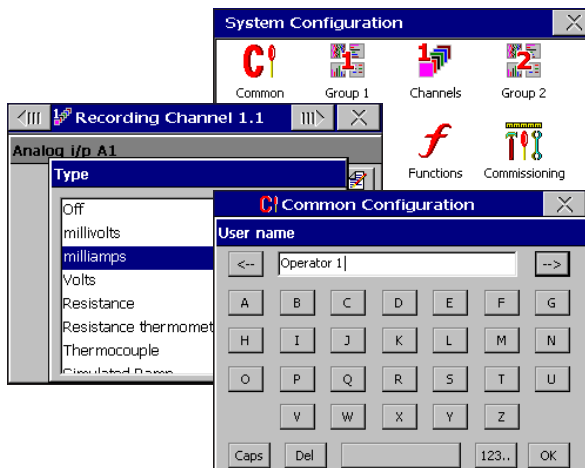

Configuration

During configuration mode the touch screen of the SM2000 comes into operation. A simple Windows™-style structure provides an intuitive approach to the setup of the recorder. Numerical and text values are quickly entered via the on-screen keyboard.

It is also possible to configure the SM2000 with a Windows-based PC configuration package.

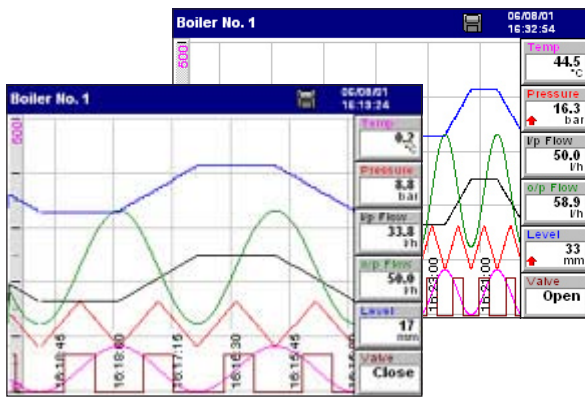

On-line Data Review

The SM2000 provides a number of unique features to provide a clear view of your process.

- The screen interval can be altered to display between 18s and 7 days of information, without it affecting the sample rate. This gives you the ability to 'zoom in' to a close-up view of the most current data or 'zoom out' and get the big picture.
- Individual traces can be temporarily removed from the screen to enable clear comparison of two or more channels.
- The instrument can easily review all historical data in the 8Mb internal buffer memory at the touch of a button. During this time, recording of the process data to the internal memory remains unaffected.



Off-Line Review and Analysis

Using ABB's DataManager software, archived process data and historical logs recorded to a removable media card can be reviewed easily.

- Database management of data files provided by DataManager ensures simple, secure long-term storage and retrieval of historical data.
- The graphing capabilities provided by DataManager ensure easy interrogation of process data.
- The validity of all data files is always checked by DataManager during the storage and retrieval process ensuring maximum data integrity.

For further information on the capabilities of DataManager, refer to data sheet SS/DATMGR.

Math and Logic

Available as an option are advanced math and logic capabilities. 12 multi-element math and 12 multi-element logic equations can be programmed via the touch screen of the recorder. Equations can be nested in to each other to provide extensive capabilities.

- Mean, standard deviation and rolling averaging functions are provided.
- Standard addition, subtraction, multiplication and division are complimented with Log, Ln, Square root, power, Sin, Cos, Tan and absolute functions.
- Switching of process signals can be achieved via the high/low/mid signal selection and multiplexing functions.
- Predefined equations are provided for relative humidity and F0 calculation.
- AND, NAND, OR, NOR, XOR, and NOT operators are available with the logic equations.

All math and logic equation results can be recorded on the display of the recorder and archived to removable media. Detailed diagnostic functions are provided for both the math and logic equations.

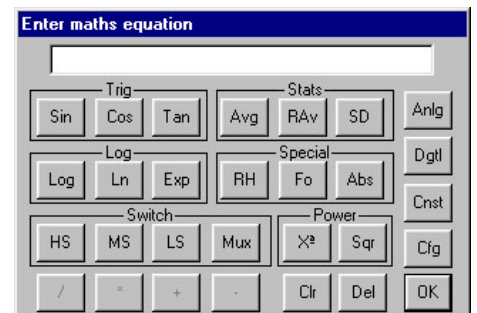

Ethernet Communications

The SM2000 can provide 10BaseT Ethernet communications via a standard RJ45 connector and uses industry-standard protocols TCP/IP, FTP and HTTP. The use of standard protocols enables easy connection into existing PC networks.

Data File Access via FTP (File Transfer Protocol)

The SM2000 features FTP server functionality. This functionality provides high-speed access via Ethernet to data archived by the recorder.

- Using a standard web-browser or other FTP clients, data files contained within the SM2000's internal memory and memory card can be accessed remotely and transferred to a PC or network drive.
- Four individual FTP users can be programmed into the SM2000. Access rights can be configured for each user specifying their access level.
- All FTP log-on activity is recorded in the audit log of the SM2000.
- Using ABB's data file transfer scheduler program, data files from multiple recorders can be automatically backed-up to a PC or network drive for long term storage ensuring the security of valuable process data and minimizing the operator intervention required.

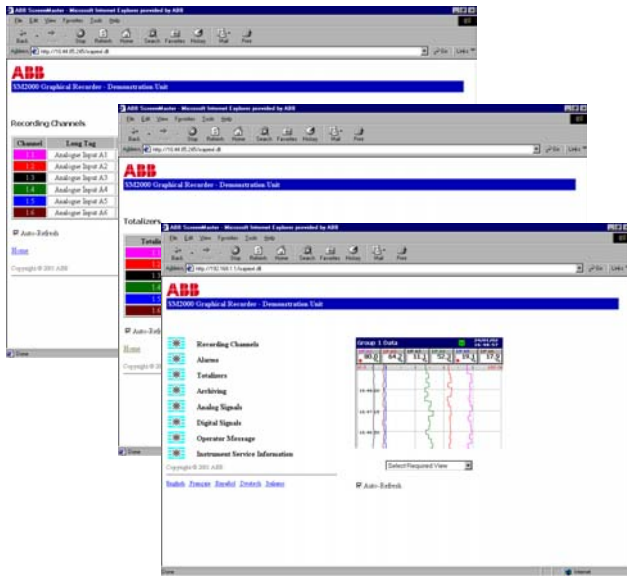
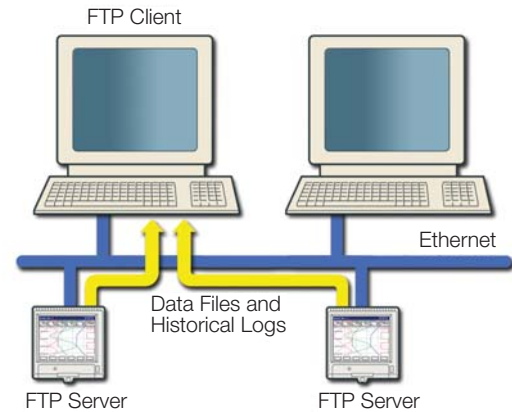

Embedded Web Server

Contained within the SM2000 is an embedded web-server allowing access to web pages created within the recorder. The use of HTTP (Hyper Text Transfer Protocol) enables standard web browsers to view these pages.

- Detailed with the web pages is the current display of the recorder, detailed information on process signals, alarm conditions, totalizer values and other key process information.
- The historical logs stored in the SM2000's internal buffer memory can be displayed in full from within the web pages.
- Operator messages can be entered via the web server allowing comments to be logged to the recorder.
- All of the information displayed on the web pages is regularly refreshed enabling them to be used as a process supervision tool.

On-line Demonstration

A demonstration of these features is available from an on-line recorder accessible via the internet. In the address bar of your web browser enter 'http://217.33.207.105'.

Remote Access/Monitoring

Ethernet communications can provide a link to recorders installed in remote locations. Via the use of a dial-up router an SM2000 can be installed in a remote location and accessed via a public telephone network when required.

Email Notification

Using its inbuilt SMTP client, the SM2000 is able to email notification of important events. Emails triggered from process alarms or other critical process events can be sent to multiple recipients. The recorder can also be programmed to email reports of the current process status at specific times during the day. Status report content can be tailored to suit your specific process needs.

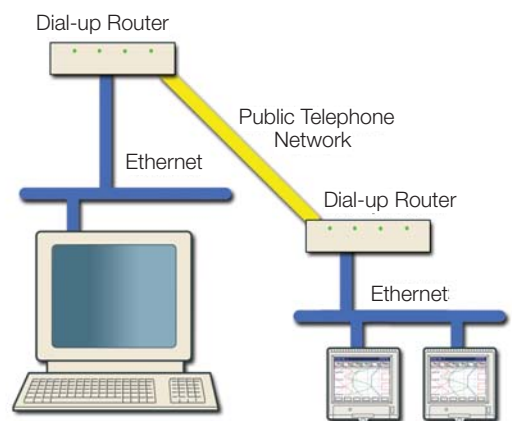

Specification

Operation and Configuration

Configuration

Via analog resistive touchscreen on front panel or PC Configuration

Multiple configuration files can be stored in internal (up to 16 files) or external memory (with removable media option fitted)

Security

4 individual passwords for each user/class of user

Two security modes: Password protection; Internal security switch protection

Provision for tamper-proof seal to prevent unauthorized changing of the configuration mode when using the internal security switch mode

Lock on media door as standard

Configuration ports

3.5mm jack socket for connection to RS232 port on a PC via an adapter

Display

Thin film transistor (TFT), active-matrix, color, liquid crystal display (LCD) with built-in backlight

Low Reflective, 14cm (5.7 in.) diagonal display area, 76800 pixel display*

Viewing angle – Horizontal 45° (typ. Left side, Right side)

Vertical 30° from below, 15° from above

***Note.** A small percentage of the display pixels may be either constantly active or inactive. Max. percentage of inoperative pixels <0.01%.

Screensaver

Can be programmed to dim the backlight if operator keys are not pressed for a selected period of time

Languages

English, German and French (Italian and Spanish pending)

Dedicated operator keys

- Group select
- View select
- Menu key
- Up/Increment key
- Down/Decrement key
- Enter key

Chart screen intervals

Selectable from 18s to 7 days

Chart scales

Independent primary and secondary ranges for each channel

Chart divisions

Programmable for up to 10 major and 10 minor divisions

Chart annotation

Alarm and operator messages may be annotated on the chart

Icons to identify the type of event, time of occurrence and tag are displayed

Operator Views

Contents	Views Available			
	Chart	Bargraph	Digital Indicator	Process
Instantaneous values/states	✓	✓	✓	✓
Units of measure	✓	✓	✓	✓
Short tags	✓	✓	✓	✓
Long tags				✓
Alarm status	✓	✓	✓	✓
Alarm trip markers		✓		
Alarm trip values				✓
Max./Min. markers		✓		
Analog bargraphs		✓		
Totalizer values & units of measure			✓	✓
Totalizer tags				✓
Max., min. and average batch values				✓
Graphical view of historical data	✓			

...Specification

Standard Functionality

Operator Messages

Number

24 configurable messages of up to 20 characters each
1 operator defined message of up to 20 characters

Trigger

Via front panel or digital signals

Recording in alarm/event log

Can be enabled or disabled on configuration

Process Alarms

Number

24 (2 per recording channel)

Types

High/low: process, latch & annunciator
Rate: fast/slow

Tag

20-character tag for each alarm

Hysteresis

Programmable value and time hysteresis – 1 to 9999s

Alarm enable

Allows alarm to be enabled/disabled via a digital input

Alarm log enable

Recording of alarm state changes in the alarm/event log can be enabled/disabled for each alarm

Acknowledgement

Via front panel or digital signals

Update rate

300ms

Real-time Alarms

Number

4

Programmable

Day of the week, 1st of month, start and duration times

Totalizer

Number

12 (1 per recording channel) 10-digit totals

Type

Analog or digital, batch and secure totals

Statistical calculations

Average, maximum, minimum (for analog signals)

Update rate

300ms

Custom Linearization

Number

2

Number of breakpoints

20 per linearizer

Recording – to Internal Memory

Data Channels

Internal buffer memory

8Mb Flash memory provides storage for 2.9 million samples

Oldest data is automatically overwritten by new data when memory is full

Data integrity checks

Checksum for each block of data samples

48-bit code for error detection/correction built-in

Independent process groups

2

No. of recording channels

12 (6 per group)

Sources

Analog inputs, Modbus inputs, any digital signal

Filters

Programmable for each channel to allow recording of: instantaneous values, average, max., min. and max. & min. value over sample time

Primary/secondary sample rates

Programmable from 0.1s to 12 hours for each recording channel

Primary/secondary sample rate selection

Via any digital signal or from password protected menu

Recording start/stop control

Via any digital signal or from password protected menu

Recording Duration

Approximate duration calculated for continuous recording of 6 channels of analog data (for 12 channels divide by 2, for 3 channels multiply by 2 etc.)

Sample Rate	1s	10s	40s	60s	120s	480s
8Mb Internal Flash buffer memory	5 days	55 days	7 months	11 months	22 months	7 years

...Specification

Historical logs

Types

Alarm/Event, Totalizer and Audit logs

No. of records in each historical log

Up to 300 in internal memory

Oldest data is automatically overwritten by new data when log is full

Historical Logs

Log Type	Alarm/Event Log		Totalizer Log		Audit Log	
Log Entry Events Information Recorded in Log	<ul style="list-style-type: none"> Alarm state changes Operator messages 		<ul style="list-style-type: none"> User defined logging intervals Totalizer stop/start, reset, wrap Power up/down 		<ul style="list-style-type: none"> Configuration/calibration changes System events Errors, operator actions 	
	In Log	On Screen	In Log	On Screen	In Log	On Screen
Date & time of event	✓	✓	✓	✓	✓	✓
Type of event	✓	✓	✓	✓	✓	✓
Tag	✓	✓	✓	✓		
Source tag	✓		✓			
Alarm trip value & units of measure	✓					
Alarm state	✓	✓				
Alarm acknowledgement state	✓	✓				
Operator ID	✓				✓	✓
Description					✓	✓
Batch total and units of measurement			✓	✓		
Max., min. and average values plus units			✓	✓		
Secure total			✓			

Archiving – to Removable Media Card

Removable storage media options

- None
- SmartMedia (3.3V only)
- Compact Flash

File types that can be saved to removable media

- Recorded data for group 1 & 2 channels
- Alarm event log for group 1 & 2 alarms/events
- Totalizer log for group 1 & 2 totals
- Audit log
- Configuration

File structure

Configurable as either binary encoded or comma-separated

File name

20-character tag, prefixed with date/time according to the new file generation interval selected

Data verification

Carried out automatically on all writes to removable-media files

	Binary	Comma-separated
File protection	Secure binary format with data integrity checks	Encrypted digital signature
New file generation interval	Automatic	Programmable for automatic file generation every hour, day or month
Archive sample rates	Programmable from 0.1s to 12 hours for each process group*	Programmable from 1s to 12 hours for each process group

*For sample rates faster than 1s the performance of the analog input card must be considered. For further information refer to page 14 of this data sheet. Further information is also available from your local ABB representative.

Recording Duration

Approximate duration calculated for continuous recording of 6 channels of analog data (for 12 channels divide by 2, for 3 channels multiply by 2 etc.)

Binary Encoded File

Sample Rate	1s	10s	40s	60s	120s	480s
128Mb SmartMedia/Compact Flash	4 months	40 months	13 years	20 months	39 years	159 years
256Mb SmartMedia/Compact Flash	8 months	80 months	26 years	39 years	79 years	319 years
512Mb SmartMedia/Compact Flash	16 months	161 months	53 years	79 years	159 years	638 years
1Gb SmartMedia/Compact Flash	31 months	26 years	103 years	155 years	311 years	1246 years

Comma-separated File

Sample Rate	1s	10s	40s	60s	120s	480s
128Mb SmartMedia/Compact Flash	0.9 months	8 months	35 months	53 months	8 years	35 years
256Mb SmartMedia/Compact Flash	2 months	17 months	71 months	8 years	17 years	70 years
512Mb SmartMedia/Compact Flash	4 months	35 months	11 years	17 years	35 years	140 years
1Gb SmartMedia/Compact Flash	7 months	5 years	22 years	34 years	68 years	275 years

Note. Windows CE limits the size of the card to 2Gb.

...Specification

Analog Input Modules

General

Number of inputs

6 per board, max. of 12 inputs

Input types

Milliamps, millivolts, voltage, resistance, THC, RTD, digital input

Digital input types

Type Volt-free contact
Minimum pulse duration 1s

Thermocouple types

B, E, J, K, L, N, R, S, T

Resistance thermometer

PT100

Other linearizations

\sqrt{x} , $x^{3/2}$, $x^{5/2}$, custom linearization

Digital filter

Programmable 0 to 60s

Display range

-999 to 9999

Common mode noise rejection

>120dB at 50/60Hz with 300 Ω imbalance resistance

Normal (series) mode noise rejection

>60dB at 50/60Hz

CJC rejection ratio

0.05 $^{\circ}$ C/ $^{\circ}$ C

Sensor break protection

Programmable as upscale or downscale

Temperature stability

0.02%/ $^{\circ}$ C or 2 μ V/ $^{\circ}$ C

Long term drift

<0.2% of reading of 20 μ V annually

Input impedance

>10M Ω (millivolts inputs)
500k Ω (voltage inputs) externally mounted divider
10 Ω (mA inputs) externally mounted on terminals*

*Hart transmitters require a minimum 250 Ω loop impedance. A 250 Ω shunt resistor can be used together with the voltage divider board (GR2000/0375) to meet this requirement. In such cases the input should be programmed for 1 to 5V.

Standard/High Specification Analog Input Modules

Linear Inputs	Standard Analog Input	High Specification Analog Input	Accuracy (% of reading)
Millivolts Milliamps Volts Resistance Ω	0 to 2000mV 0 to 50mA 0 to +20V* 0 to 5000 Ω	-1000 to +1000mV -100 to +100mA -50 to +50V* 0 to 2000 Ω	0.1% or \pm 10 μ V 0.2% or \pm 2 μ A 0.2% or \pm 10mV 0.2% or \pm 0.08 Ω
Sample Interval	100ms per sample (2 modules are processed in parallel) gives worst case update times as follows: 600ms for 6 or 12 channels – mV, mA, voltage 800ms for 6 or 12 channels – THC 1100ms for 6 or 12 channels – resistance, RTD	100ms per sample (2 modules are processed in parallel) gives worst case update times as follows: 100ms for 6 or 12 channels – all input types	
Input Isolation	35V DC channel-to-channel	500V DC channel-to-channel	
Isolation from Rest of Instrument	Galvanically isolated to 500V DC	Galvanically isolated to 500V DC	

* Requires external voltage divider board Part No. GR2000/0375

Analog Input Types

Thermocouple	Maximum Range °C	Maximum Range °F	Accuracy (% of reading)
B	-18 to 1800	0 to 3270	0.1% or $\pm 2^{\circ}\text{C}$ (3.6°F) (above 200°C [392°F])
E	-100 to 900	-140 to 1650	0.1% or $\pm 0.5^{\circ}\text{C}$ (0.9°F)
J	-100 to 900	-140 to 1650	0.1% or $\pm 0.5^{\circ}\text{C}$ (0.9°F)
K	-100 to 1300	-140 to 2350	0.1% or $\pm 0.5^{\circ}\text{C}$ (0.9°F)
L	-100 to 900	-140 to 1650	0.1% or $\pm 1.5^{\circ}\text{C}$ (2.7°F)
N	-1200 to 1300	-325 to 2350	0.1% or $\pm 0.5^{\circ}\text{C}$ (0.9°F)
R	-18 to 1700	0 to 3000	0.1% or $\pm 1^{\circ}\text{C}$ (1.8°F) (above 300°C [540°F])
S	-18 to 1700	0 to 3000	0.1% or $\pm 1^{\circ}\text{C}$ (1.8°F) (above 200°C [392°F])
T	-250 to 300	-400 to 550	0.1% or $\pm 0.5^{\circ}\text{C}$ (0.9°F)

RTD	Maximum Range °C	Maximum Range °F	Accuracy (% of reading)
PT100	-200 to 600	-325 to 1100	0.1% or $\pm 0.5^{\circ}\text{C}$ (0.9°F)

RS485 Serial Communications

Number of ports

1 as standard

Connections

RS485, 2- or 4-wire

Protocol

Modbus RTU slave

2-wire Transmitter Power Supply

Number

1 fitted as standard

Voltage

24V DC

Drive

Up to 50mA, i.e. can drive 2 loops

Advanced Math

Math Blocks

Type

12 equations provide ability to perform general arithmetic calculations including F_o , mass flow, relative humidity and emissions calculations

Size

40-character equation

Functions

+, -, /, log, Ln., Exp, X^n , $\sqrt{\quad}$, Sin, Cos, Tan, mean, rolling average, standard deviation, high/median/low select, multiplexer, absolute, relative humidity

Tags

8- and 20-character tags for each block

Update rate

1 enabled Math block is updated every 100ms

Logic Equations

Number

12

Size

11 elements each

Functions

AND, OR, NAND, NOR, XOR, NOT

Tags

20-character tag for each equation

Update rate

300ms

Modules

3- or 6-Relay Output Modules

Number of relays

3 or 6 per module

Type and rating

Relay type single-pole changeover

Voltage 250V AC 30V DC

Current 5A AC 5A DC

Loading (non-inductive) 1250VA 150W

Note. The total load for all relays within the instrument must not exceed 36A.

...Specification

Hybrid Module

Digital I/O

Number	6 inputs and 6 outputs per card
Type	Volt-free switching inputs
Polarity	Negative i.e. closed switch contact or 0V = active signal
Digital input min. pulse	100ms
Digital output voltage	5V
Isolation	500V DC from any other I/O

Analog output

Number	2 isolated
Configurable current range	0 to 20mA
Max. load	750Ω
Isolation	500V DC from any other I/O
Accuracy	0.25%

2-wire Transmitter Power Supply Module

Number

2 isolated supplies per module

Voltage

24V DC nominal

Drive

45mA per supply, i.e. each module can drive 2 x 2 = 4 loops

Ethernet Module

Physical medium

10BaseT

Protocols

TCP/IP, ARP, ICMP, FTP (server), HTTP

FTP server functions

- Directory selection & listing
- File upload/download
- Four independently configurable users with full or read-only access

Web server functions

Operator screen monitoring/selection. Remote monitoring of recording channels, analog/digital signals, alarms, totalizers and archiving.

EMC

Emissions & immunity

Meets requirements of:
EN50081-2
EN50082-2
EN61326 for an industrial environment

Electrical

Power supply

85V min. to 265V max. AC 50/60Hz
(Optional) 24V DC ±4V

Power consumption

35VA max

Power interruption protection

No effect for interrupts of up to 20ms

Maximum accepted cable size

Instrument terminal block	14AWG (1.63mm OD)
GR2000/0375, GR2000/0377	15AWG (1.43mm OD)

Safety

General safety

EN61010-1
Overvoltage Class III on mains, Class II on inputs and outputs
Pollution category 2

Isolation

500V DC to earth (ground)

Environmental

Operating temperature range

0 to 50°C (32 to 122°F) with SmartMedia/Compact Flash

Operating humidity range

5 to 95%RH (non-condensing)

Storage temperature range

-10 to 60°C (14 to 140°F)

Front panel sealing

IP66 and NEMA4X

Rear panel sealing

(with rear cover) IP40
(without rear cover) IP20

Vibration

Conforms to EN60068-2

Physical

Size

144mm (5.67in.) x 144mm (5.67in.) x 195mm (7.68 in.)
(depth behind panel)

Weight

2.6kg (5.6 lb) approx. (unpacked)

Panel cutout

138mm (5.43 in.) x 138mm (5.43 in.)

Case material

10% glass-filled polycarbonate

Display housing material

40% glass-filled polycarbonate

Touchscreen

Double layer polyester coated toughened glass

Electrical Connections

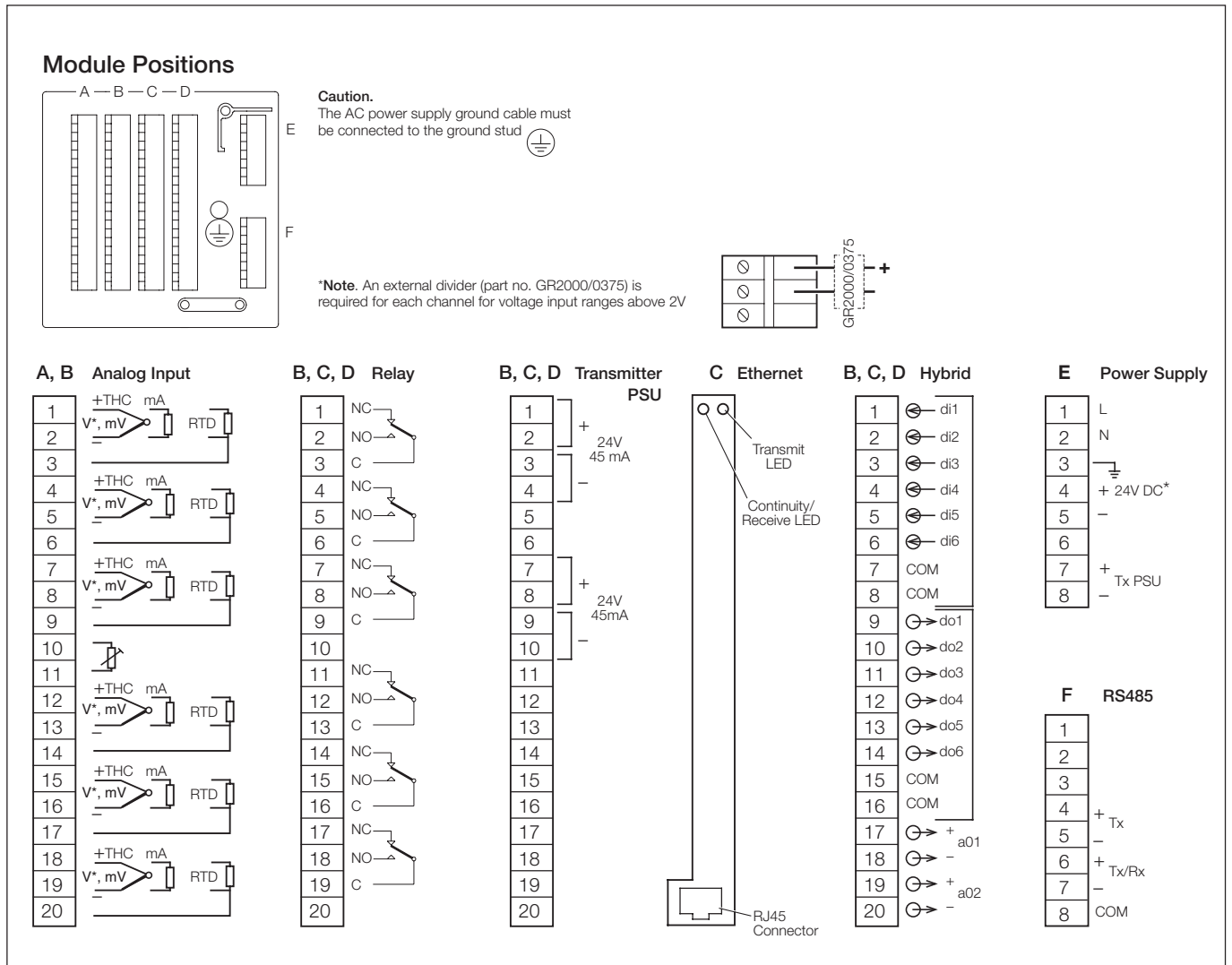

*Note. 24V DC instrument power supply must be specified when ordering.

Overall Dimensions

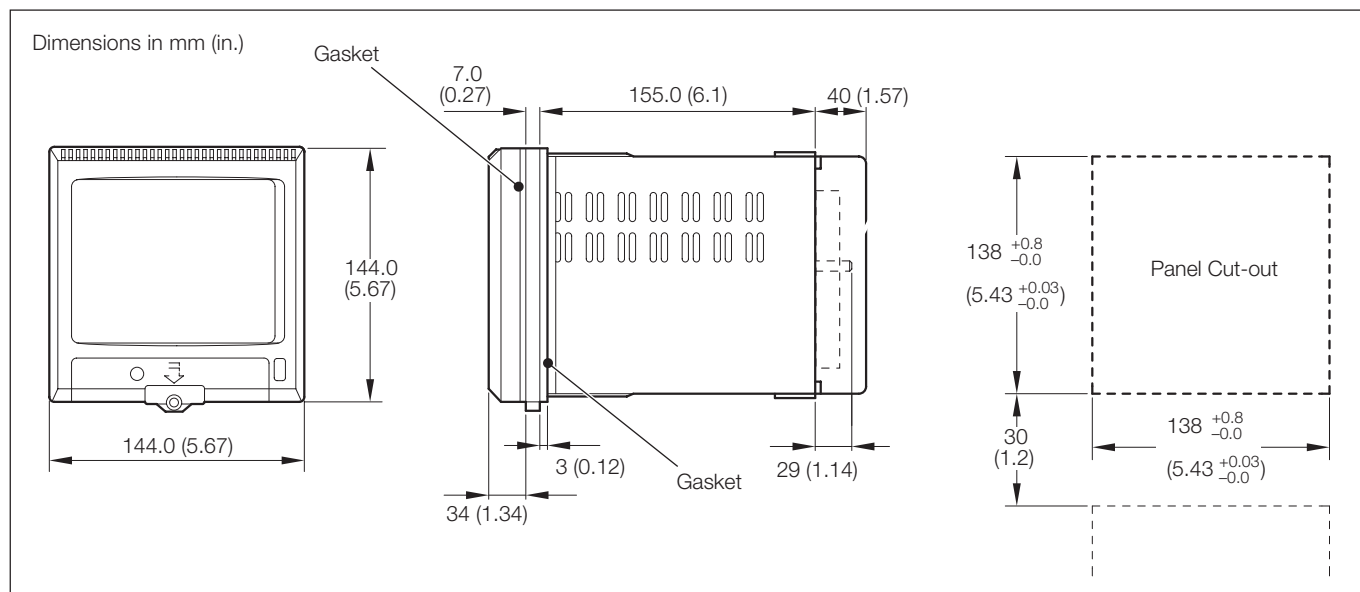

Ordering Information

SM2000 Advanced Videographic Recorder		SM20	XXX/	X	X	X/	X	X	X	X/	X	X/	XXX
Universal Analog Inputs	None		00S										
	6 – standard specification		06S										
	12 – standard specification		12S										
	6 – high specification		06H										
	12 – high specification		12H										
Build Option	Standard			B									
	cCSAus			C									
Archive Media	None – (8Mb internal flash memory only)				0								
	SmartMedia drive				1								
	Compact flash drive				2								
Software Option	None					0							
	Advanced Math					1							
Option Modules													
Position A	Reserved for analog inputs						0						
Position B	Reserved for analog inputs if 12 inputs are specified							0					
	3 relays							3					
	6 relays							6					
	Hybrid – 6 digital inputs, 6 digital outputs, 2 analog outputs							H					
	2-wire transmitter power supply							T					
Position C	None								0				
	3 relays								3				
	6 relays								6				
	Ethernet (10BaseT) communications								E				
	Hybrid – 6 digital inputs, 6 digital outputs, 2 analog outputs								H				
2-wire transmitter power supply								T					
Position D	None									0			
	3 relays									3			
	6 relays									6			
	Hybrid – 6 digital inputs, 6 digital outputs, 2 analog outputs									H			
	2-wire transmitter power supply									T			
Front Bezel Style	Standard IP66 and NEMA4X with media door lock										0		
Power Supply	85V min. to 265V max. AC												2
	24V DC												3
Special Features	Standard												STD
	Custom configuration												CUS

Optional Accessories

Part No. Description

SmartMedia Cards

B11862	SmartMedia Card (64Mb)
B11863	SmartMedia Card (128Mb)

Compact Flash Card

B11867	Compact Flash Card (128Mb)
--------	----------------------------

Part No. Description

Universal Card Reader

B12028	Smart Media and Compact Flash Card Reader (USB Interface)*
--------	--

Other

GR2000/0375	Voltage divider board (2 to 20V) – per voltage input channel
GR2000/0377	Voltage divider board fitted with 250Ω shunt resistor
SW/DATMGR	DataManager Software

* Compatible with Windows 98/98se, ME, 2000 & XP

Licensing, Trademarks and Copyrights

Modbus™ is a trademark of Modicon, Inc.

Windows™ is a trademark of the Microsoft Corp.

ABB has Sales & Customer Support
expertise in over 100 countries worldwide

www.abb.com

The Company's policy is one of continuous product
improvement and the right is reserved to modify the
information contained herein without notice.

Printed in UK (08.06)

© ABB 2006



ABB Limited

Howard Road, St. Neots
Cambridgeshire
PE19 8EU
UK
Tel: +44 (0)1480 475321
Fax: +44 (0)1480 217948

ABB Inc.

125 E. County Line Road
Warminster
PA 18974
USA
Tel: +1 215 674 6000
Fax: +1 215 674 7183