

- **12-channel recording on 250mm chart**
 - with individual trace colors
- **Universal process inputs**
 - accepts thermocouples, RTDs, mA, mV & V
- **Clear text annotation on chart**
 - time, date, scales, speed, alarms and batch
- **High clarity graphics display**
 - shows process status at a glance
- **Dust- and water-resistant to IP65 (NEMA3)**
 - for harsh industrial environments
- **Modbus™ serial communications**
 - provide full integration with your control system



SR250B
– Simplicity and ease of use in a
rugged, compact 250mm recorder

SR250B

The SR250B provides accurate and reliable recording of up to 12 process signals on a 250mm wide chart. In-built text printing capabilities give clear annotation on the chart of time, date, scales and other process information.

The clear view of process status from the LCD display, with the simplicity of chart and pen replacement, make the SR250B extremely easy to operate.

The recorder is designed for panel-mounting and provides IP65 (NEMA3) dust and water protection on the front face, making it suitable for use in harsh environments.

The SR250B can be configured for a wide range of input types and chart speeds and is ideal for most industrial recording applications.

Application areas include:

- Heat Treatment
- Ceramics Manufacture
- Cold Storage
- Power Generation

Process Connections

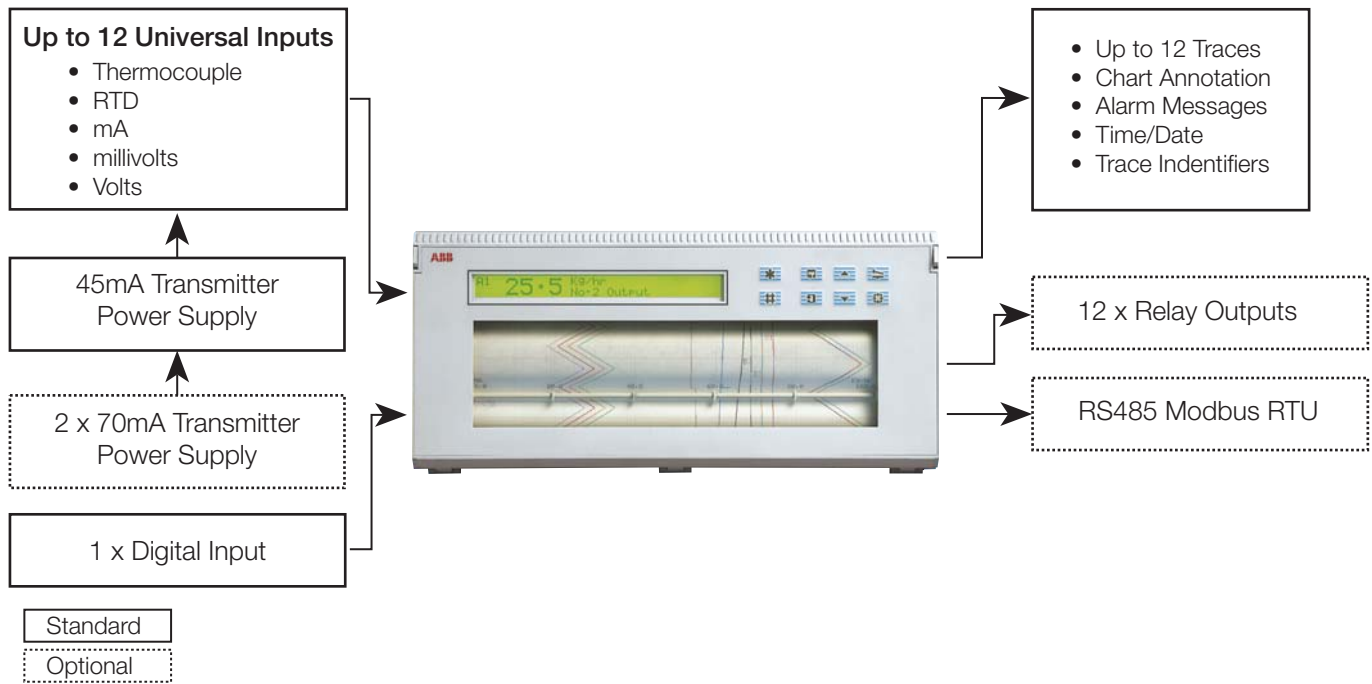

Recording

The SR250B's high-speed multi-point printing system updates all 12 traces in 2.2 seconds. This system produces continuous lines on the chart at speeds of up to 500mm/hr.

The printing sequence is intelligently managed by the recorder's control system to give priority to fast-changing signals, ensuring the most comprehensive process record is traced on the chart.

The SR250B supports full text printing to provide detailed annotation on the chart. In addition to the time, date, channel identity and chart speed, the recorder can print scales for each channel, alarm messages and an Operator-entered batch name.

The 'Easy-view' facility enables the user to see the latest recordings at the push of a button.



Unique Post-incident Analysis (Cue-and-Review)

The SR250B's unique 'Cue-and-Review' facility allows the user to rapidly search any part of the roll chart for process events or alarm occurrence – enabling rapid and accurate analysis of process records.

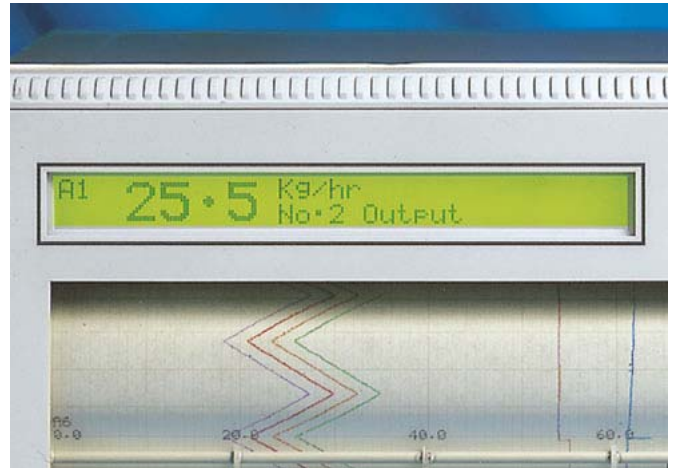

Operation

A graphic liquid crystal display (LCD) provides exceptional clarity for day-to-day operation and for configuration.

During normal operation the display cycles through each channel in sequence, showing the measured value, engineering units, description and channel identifier.

Clear text prompts on the LCD display assist the Operator in accessing functions such as chart reload and alarm acknowledge. Tactile membrane keys on the front of the recorder are used to access these functions. A second, identical keypad is provided inside the recorder for use when the door is open.

Password protection prevents unauthorized access to the recorder's configuration.

Quickly-fitted pen cartridges and an easily-removable chart cassette ensure simple and efficient pen and chart replacement.

Set-up

The SR250B can be easily set up to match your process in either of two ways:

Entry of the correct password via the keypad on the front of the unit gives access to the recorder's configuration. A simple menu structure with clear text descriptions provides an intuitive approach to the recorder set-up.

The preferred configuration method for multiple SR250B recorders is by means of the PC Configurator. This Windows™-based package provides a simple 'point-and-click' approach to generating a full recorder configuration off-line. The completed configuration can be printed-out or saved onto disk before being downloaded to the recorder.

An SR250B interface cable is used to provide the connection between the PC's serial port and the configuration port on the recorder.



Option Modules

All recorders are fitted with at least one universal input module for analog process signals plus a transmitter power supply for up to two 2-wire transmitters.

The capabilities of your recorder can be extended by the addition of further option modules. Each recorder can support up to 2 input modules plus 3 option modules.

I/O Options

Type	Standard	Option
Universal Inputs	3, 6, 9 or 12	
Relays	0	12
Transmitter Power Supply (loops)	2	12
Serial Communications	X	✓

Application Function Overview

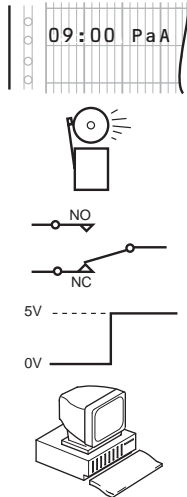

The recorder prints time, date and chart speed automatically at regular intervals. Channel scales and batch identifiers can also be printed on the chart periodically or on demand.

Up to 24 process alarms can be set up within the recorder. Alarm status can be printed on the chart and the alarms can operate relay outputs or change the chart speed.

A maximum of 12 relays can be fitted within the recorder for use as alarm outputs. A single common relay can be set to be triggered by multiple alarms.

A digital input is provided on every Input Module for remote changing of chart speed or for alarm acknowledgment.

RS485 2- or 4-wire communications using Modbus protocol provides a real-time link to SCADA systems or PLCs.

Temperature Recording

Recording of temperature, using both direct-connected thermocouples and RTDs or 2-wire field-mounted transmitters, is common in a wide range of industries such as Aerospace, Car component, Food, Chemical and Kiln/Ovens.

The SR250B can accept direct connection to all standard thermocouples, Pt100 resistance thermometers and 4 to 20mA transmitters, and record on up to 6 channels or datalog up to 12 inputs.

Operator messages allow printing of configurable messages such as 'Start of Test' or 'Cycle Complete' for a clear record of the batch.

For electric ovens fit the 500V isolator card to avoid conductance on the thermocouple which causes noise on the chart.

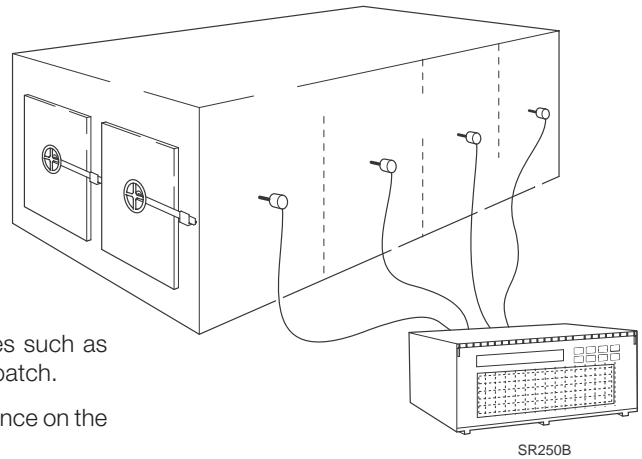

Temperature Monitoring and Alarms

In food production, it is essential to monitor the conditions in Cold Stores and Temperature-controlled Rooms to provide the user with a record that the goods have been stored at the correct temperature.

The simplest and easiest way to do this is with the SR250B strip chart recorder, which can take up to 6 inputs from RTDs spread across a cold store or a number of food preparation areas.

At a chart speed of 20mm/hour, the unit provides recording for one month and, when fitted with relay output modules, provides alarm functions.

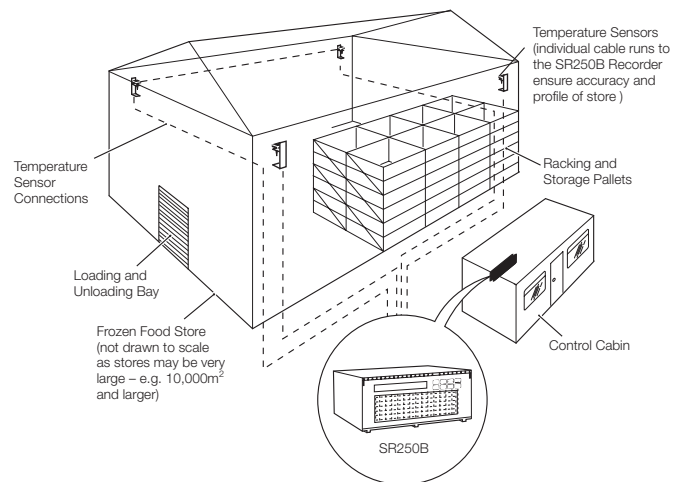

Specification

Chart

Traces

Up to 12

Colors

Channels 1 to 6	Magenta, Red, Black, Green, Blue and Brown
Channels 7 to 12	Bi-color, Z-traces

Pen life

3 months typically (at 20mm/hr with normal scale printing)

Chart

25m Roll chart
Quick-load cassette
Standard chart graduation 100 divisions
80, 120, 140, 150 divisions also available

Chart speed

Configurable between 1 and 1500mm/hr in 1mm/hr steps
Remote speed change

Trace response

2.2s for print-out of 12 traces
1.5s for print-out of 6 traces

Trace resolution

0.2mm

Text messages

1 operator message for batch identification (20-characters)
24 alarm messages (20 characters)

Operation

Graphics display – backlit LCD

Characters	10.4mm high – process variables
	5.1mm high – text

Display of process variable

Engineering range –999 to +9999

Languages

User-configurable for English, French or German

Keys

Sealed tactile membrane	duplicate keypads on door and inside case
-------------------------	---

Analog Inputs

Number

3 or 6 Standard
9 or 12 Optional

Input sampling rate

125ms per channel – 12 channels in 1.5s

Type

Universally configurable for:
Thermocouple (THC)
Resistance thermometer (RTD)
Millivolt, Current, Voltage, Resistance

Linearizer functions

Programmable for all inputs including $\sqrt{\quad}$, $x^{3/2}$, $x^{5/2}$
THC types B, E, J, K, R, S, T, L, N, Pt100
Two 20-breakpoint custom linearizers

Broken sensor detection

Programmable to drive Upscale or Downscale
RTD short/open circuit detection

Cold junction compensation

Automatic CJC incorporated as standard
< 0.05°C per °C (0.1°F per °F)/change in ambient

Input impedance

Current	10Ω
Voltage	500kΩ
mV & THC	>10MΩ

2-wire transmitter power supply

45mA max. (2 loops), fitted as standard
Additional loops can be powered from optional TXPSU modules

Input

Channel-to-channel	12V DC dielectric strength
Channel to ground	500V DC dielectric strength

Common mode rejection

>120dB at 50/60Hz with 300Ω imbalance resistance

Series mode rejection

>60dB at 50/60Hz

Temperature stability

0.02% of reading/°C (0.01% of reading/°F) or 2μV/°C (1μV/°F) (whichever is greater)

Long term drift

< 0.01% of reading or ±5μV annually

Filtering

Off, 5 to 60s digital filter

Alarms

- 24 high/low process alarms with programmable level and time hysteresis
- 4 real-time events with programmable on-time and duration

Electrical

Power supply

- 85 to 265V 50/60Hz
- 24V DC \pm 4V (optional)

Line interruption

- <80ms loss, no effect
- >80ms loss, auto-reset and restart

Power consumption

- 35VA max

Electrical safety

- EN61010-1, IEC348
- CSA (optional)

Electrical connections

- Screw terminals

Option Modules

3- or 6-relay output module

- Universally assignable to any alarm signal
- Relay type Single pole changeover
- Voltage 250V AC 30V DC
- Current 5A AC 5A DC
- Loading (non-inductive) 1250VA 150W

Note. The total load for all relays within the instrument must not exceed 36A.

2-wire transmitter power supply module

- Two isolated 24V outputs (45mA each)
- Each output capable of driving 2 loops

RS485 serial communication (Modbus) module

- | | |
|-----------------------------|------------------------------|
| EIA communications standard | RS485 (2- or 4-wire) |
| Protocol | Modbus RTU (slave) |
| Baud rate | User selectable up to 9600 |
| Isolation | 500V from rest of instrument |

Physical

Size

- 326.8mm (12.87 in.) x 147mm (5.78 in.) x 230mm (9.00 in.) (depth behind panel)

Weight

- <6kg (13lbs.) approx.

Panel cut-out

- 303mm (11.92 in.) x 138mm (5.43 in.)

Case material:

- Stainless steel, painted

Door material

- Glass-filled polyarylamide

Window material

- Polycarbonate

Keyboard material

- Polyester

Environmental

Operating limits

- 5 to 50°C (41 to 122°F),
- Electronics <95%RH (non-condensing)
- Chart <80%RH (non-condensing)

Storage temperature limits

- 20 to 80°C (4 to 176°F)

Dust/Water protection

- Front face IP65 (NEMA3)
- Rear of instrument IP20

Electromagnetic compatibility

- EN50081-2, EN50082-2
- CE marked

Vibration

- Designed to meet IEC68

EMC

Emissions and Immunity

Meets requirements of:

EN50081-2

EN50082-2

EN61326 for an industrial environment

CE Mark

...Specification

Input Ranges and Accuracy

Input Ranges

Input Type	Min. Value	Max. Value	Min. Span	Accuracy (% of reading)
Millivolts	-2000	2000	2.5	±0.1% or ±10µV
Volts	-20	20	0.25	±0.2% or ±2mV
Milliamps	-100	100	0.25	±0.2% or ±2µA
Resistance	0	8000	10	±0.2% or ±0.08Ω

Thermocouple and RTD Ranges and Accuracy

THC/RTD Type	°C				°F			
	Min.	Max.	Min. Span	Accuracy	Min.	Max.	Min. Span	Accuracy
Type B	-18	1800	710	±2.0*	0	3272	1278	±3.6*
Type E	-100	900	45	±0.5	-148	1652	81	±0.9
Type J	-100	900	50	±0.5	-148	1652	90	±0.9
Type K	-100	1300	65	±0.5	-148	2372	117	±0.9
Type L	-100	900	50	±0.5	-148	1652	90	±0.9
Type N	-200	1300	90	±0.5	-328	2372	162	±0.9
Type R & S	-18	1700	320	±0.1*	0	3092	576	±1.8*
Type T	-250	300	60	±0.5	-418	572	108	±0.9

* Performance accuracy is not guaranteed below 300°C (572°F) for B, R and S thermocouples

Min. span below zero Type T 70°C (126°F)
Type N 105°C (189°F)

THC standards DIN 43710
IEC 584

RTD***	-200	600	25	±0.5**	-328	1112	45	±0.9**
--------	------	-----	----	--------	------	------	----	--------

** For temperatures between 300 and 600°C (527 and 1112°F) accuracy is ±1.0°C (±1.8°F)

*** RTD, 3-wire platinum, 100Ω per DIN43760 standard (IEC751), with range of 0 to 400Ωs

Overall Dimensions

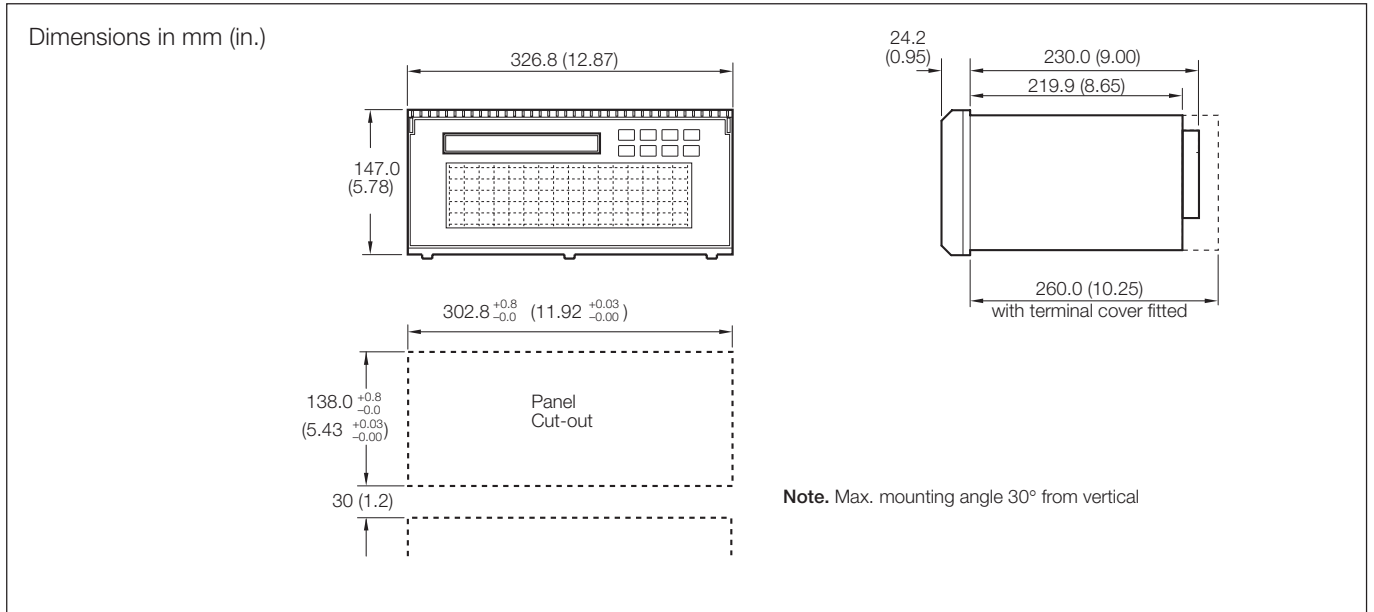

Electrical Connections

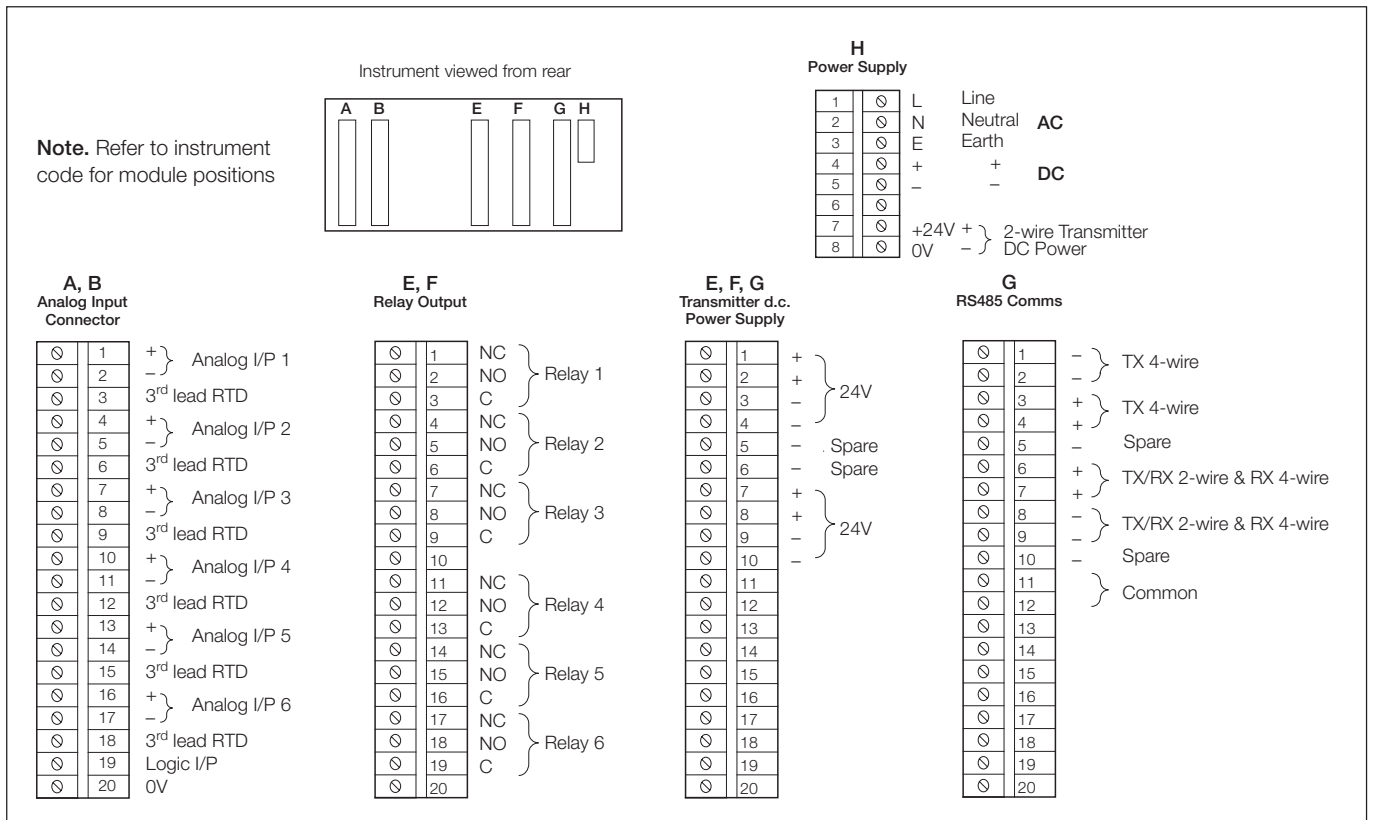

Ordering Information

SR250B Multipoint Chart Recorder	SR250B /	XXS /	X00	/ X	X	X	/ X	X	X	XX
Number of Traces and Input Channels										
3		0 3								
6		0 6								
9		0 9								
12		1 2								
Build										
ABB Standard			B							
CSA (pending)			C							
UL (pending)			U							
Option Module E										
None				0						
3 relays				3						
6 relays				6						
Transmitter power supply unit				T						
Option Module F										
None					0					
3 relays					3					
6 relays					6					
Transmitter power supply unit					T					
Option Module G										
None						0				
Modbus serial communications						S				
Transmitter power supply unit						T				
Case Option										
Standard panel mount								1		
Standard + terminal cover								2		
Chart Type										
Roll chart									1	
Power Supply										
85V to 265V AC										2
24V DC										3
Programming/Special Features										
Configured to factory standard										ST
Configured to customer requirements – see Configuration Details opposite										CM

Accessories

PC Configurator kit (part no. C100/0700)

Licensing, Trademarks and Copyrights

Modbus™ is a trademark of Modicon, Inc.

Windows™ is a trademark of the Microsoft Corp.

Configuration Details

For instrument configuration please complete this form and return it with your order.

Channel	Input Type	Linearization Type	THC and Pt100			mA, mV, V and Resistance				
			Linearizer Range			Range		Display		
			Units	Zero	Span	Zero	Span	Zero	Span	Units
1										
2										
3										
4										
5										
6										
7										
8										
9										
10										
11										
12										
ST	mA	None				4	20	0	1000	

e.g. 1	mA	None	-	-	-	4	20	0	100	bar
e.g. 2	THC	R	°C	0	1400	-	-	-	-	-

Note. Default configuration is as ST above.

ABB has Sales & Customer Support
expertise in over 100 countries worldwide

www.abb.com

The Company's policy is one of continuous product
improvement and the right is reserved to modify the
information contained herein without notice.

Printed in UK (09.05)

© ABB 2005



ABB Limited
Howard Road, St Neots
Cambridgeshire
PE19 8EU
UK
Tel: +44 (0)1480 475321
Fax: +44 (0)1480 217948

ABB Inc.
125 E. County Line Road
Warminster
PA 18974
USA
Tel: +1 215 674 6000
Fax: +1 215 674 7183