

Analyze^{IT}

Continuous Gas Analyzers

EL1020

Infrared-Gas Analyzer (with O₂ Sensor Option),
Oxygen Analyzer, Thermal Conductivity Gas Analyzer

Data Sheet

10/27-1.10 EN September 2003

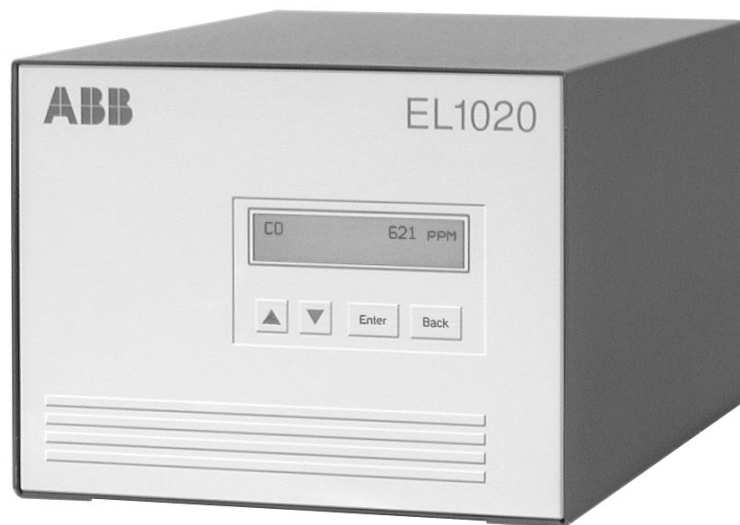

- Product line for gas concentration measurement
- Uniform operation, connections and housing
- Proven measuring technology
- Special version for measuring flammable gases available
- Simplified calibration possible
- Output of measurement values, limit and status signals via analog and digital outputs
- Extended output and control via RS232/RS485 interface with Modbus protocol
- Modbus DDE driver available
- Easy operation with 4 keys
- Compact 1/2 19" housing for desktop and rack mounting
- Modular design for ease of service

EL1020-IR Infrared-Gas Analyzer

Measurement Principle

Non-dispersive infrared absorption in the $\lambda = 2.5\text{--}8\ \mu\text{m}$ wavelength range

Photometer to measure 1 or 2 components

The electrochemical oxygen sensor can be used together with the infrared analyzer EL1020-IR. In this case, only one IR sample component is possible.

Sample Components and Smallest Measurement Ranges

CO	0–500 ppm
CO ₂	0–300 ppm
SO ₂	0–500 ppm
CH ₄	0–500 ppm
NO	0–1000 ppm
	0–500 ppm with limited performance data relative to span. The following data are based on a span of 1000 ppm.

Measurement Range Data

Quantity	1 range per sample component The measurement range is freely adjustable within a range ratio of $\leq 1:5$ ($\leq 1:8$ for CO ₂) relative to the factory-set measurement range.
Largest Measurement Range	0–100 Vol.-% or 0 Vol.-% to saturation or 0 Vol.-% to LEL Measurement ranges within ignition limits cannot be provided.
Limit Value Monitoring	1 sample component: 2 limit values 2 sample components: 1 limit value per component

Calibration

Zero-Point Calibration	with inert gas, e.g. N ₂ , or with ambient air that is free of the measurement component
End-Point Calibration	with gas-filled calibration cells (optional) or with test gas mixtures Depending on the measurement task involved, calibration cell set values should be verified periodically (Recommendation: once a year).

Note

The following measurement data are based on N₂ as the associated gas. Compliance with these data when measuring other gas mixtures can only be assured if their composition is known and ABB Analytical has verified that the analyzer is suitable for the measurement task.

Stability

The following data apply only if all influence factors (e.g. flow rate, temperature, atmospheric pressure) are constant.

Linearity Deviation	$\leq 1\%$ of span
Repeatability	$\leq 0.5\%$ of span
Zero Drift	$\leq 1\%$ of span per week
Sensitivity Drift	$\leq 1\%$ of measured value per week
Output Signal Variations	$\leq 0.2\%$ of span at $2\ \sigma$ and electronic T90 time = 5 sec
Detection Limit	$\leq 0.5\%$ of span

Influence Effects

Flow Effect	Flow rate in the range 20–100 l/h: within determination limits
Associated Gas Effect/ Cross Sensitivity	The knowledge of the sample gas composition is necessary for the analyzer calibration. Selectivity measures to reduce associated gas effect (optional): Incorporation of interference filters
Temperature Effect	Ambient temperature in the range +5 to +45 °C: At zero-point: $\leq 1\%$ of span per 10 °C On sensitivity: $\leq 3\%$ of measurement value per 10 °C
Air Pressure Effect	At zero-point: No effect On sensitivity: $\leq 0.2\%$ of measurement value per 1% barometric pressure change Pressure sensor working range: $p_{\text{abs}} = 600\text{--}1250\ \text{hPa}$
Power Supply Effect	Voltage and frequency in permissible range: $\leq 0.2\%$ of span
Position Effect	no influence effect

EL1020-IR Infrared-Gas Analyzer

Oxygen Sensor

Dynamic Response

Warm-Up Time	Approx. 30 minutes
T ₉₀ Time	T ₉₀ ≤ 2 sec for sample gas flow = 60 l/h

Materials in Contact with the Sample Medium

Analyzer (Sample Cell)	Tube: Aluminum Window: CaF ₂ Connectors: Stainless steel 1.4571
Gas Lines and Connectors	FPM (Viton), PP, PVDF; in the version for measuring flammable gases: Stainless steel 1.4571

Gas Inlet Conditions

Temperature	The sample gas dew point should be at least 5 °C below the ambient temperature throughout the sample gas path. Otherwise a sample gas cooler or condensate trap is required.
Inlet Pressure	p _e = 2–500 hPa; in the version for measuring flammable gases: p _e = 2–100 hPa (maximum value p _e = 500 hPa) Lower pressures require a sample gas pump and higher pressures require a pressure reducer.
Outlet Pressure	Atmospheric pressure
Flow Rate	20–100 l/h
Pressure Drop	< 4 hPa at 60 l/h N ₂
Corrosive Gases	Highly corrosive associated gas components, e.g. chlorine (Cl ₂) and hydrogen chloride (HCl), as well as gases or aerosols containing chlorine must be cooled or undergo prior absorption.
Flammable Gases	In the version with gas lines and connectors made of stainless steel the analyzer is suitable for measuring flammable gases. Please observe the special conditions on page 8.

Installation Site Requirements

Vibration	max. ±0.04 mm at 5–55 Hz, 0.5 g at 55–150 Hz Slight transient effect on sample value in the region of the beam modulation frequency
Ambient Temperature	Operation: +5 to +45 °C with oxygen sensor +5 to +40 °C Storage and transport: –25 to +65 °C
Relative Humidity	Operation: < 75 %

Measurement Range Data

Quantity	1 measurement range
	The measurement range is freely adjustable in the range from 0–5 Vol.-% O ₂ to 0–25 Vol.-% O ₂ ; it is factory-set to 0–25 Vol.-% O ₂ .

Calibration

Zero-Point Calibration	The oxygen sensor zero is not calibrated since it is fundamentally stable.
End-Point Calibration	With ambient air at 20.96 Vol.-% O ₂

Stability

Linearity Deviation	Linear for concentrations > 1 Vol.-% O ₂
Repeatability	≤ 0.5 % of span
Zero Drift	Stable over long-term due to absolute zero point
Sensitivity Drift	≤ 1 % of the measurement range per week
Detection Limit	≤ 0.5 % of the measurement range

Influence Effects

Flow Effect	Flow rate in the 20–100 l/h range: ≤ 2 % of the measurement range
Temperature Effect	Ambient temperature in the range +5 to +40 °C: ≤ 0.2 Vol.-% O ₂ per 10 °C
Air Pressure Effect	At zero-point: No effect On sensitivity: ≤ 0.2 % of sample value per 1 % air pressure change

Dynamic Response

T ₉₀ Time	T ₉₀ ≤ 30 sec, depending on sample gas flow
----------------------	--

Materials in Contact with the Sample Medium

Sensor	Polystyrol-ABS, Teflon, Viton
Housing Body	PVC, Viton seals
Gas Ports	Stainless steel 1.4571

Gas Inlet Conditions

	same as EL1020-IR Infrared-Gas Analyzer, additionally:
Humidity	H ₂ O dew point ≥ 2 °C The oxygen sensor should not be used for measuring dry sample gases.
Associated Gas	The oxygen sensor should not be used with flammable gases and if the associated gas contains H ₂ S, chlorine or fluorine compounds, heavy metals, aerosols, mercaptane, base components.

EL1020-O2 Oxygen Analyzer

Measurement Principle

Paramagnetic behavior of oxygen
Magnetomechanical oxygen analyzer with short T_{90} time

Sample Component and Smallest Measurement Range

O ₂	0–2 Vol.-% 0–1 Vol.-% with limited performance data relative to span. The following data are based on a span of 2 Vol.-% O ₂ .
----------------	--

Measurement Range Data

Quantity	1 measurement range The measurement range is freely adjustable; it is factory-set to 0–25 Vol.-% O ₂ .
Largest Measurement Range	0–100 Vol.-% Measurement ranges should not be set within ignition limits.
Measurement Range with Suppressed Zero-Point	Smallest span 2 Vol.-% O ₂ The suppressed measurement range is factory-set to 98–100 Vol.-% O ₂ . Smallest suppressed measurement range, e.g. 99–100 Vol.-% O ₂ , with limited performance data relative to span. A pressure sensor is installed when the analyzer has been ordered with suppressed measurement range.
Limit Value Monitoring	2 limit values

Calibration

Zero-Point Calibration	with nitrogen (N ₂)
End-Point Calibration	with test gas with concentrations in the selected measurement range
Measurement Ranges with Suppressed Zero-Point	Zero-point and end-point should only be calibrated with test gases with concentrations in the selected measurement range.

Note

The following measurement data are based on N₂ as the associated gas. Compliance with these data when measuring other gas mixtures can only be assured if their composition is known and ABB Analytical has verified that the analyzer is suitable for the measurement task.

Stability

The following data apply only if all influence factors (e.g. flow rate, temperature, atmospheric pressure) are constant.

Linearity Deviation	≤ 0.5 % of span
Repeatability	≤ 0.5 % of span
Zero Drift	≤ 0.03 Vol.-% O ₂ per week Following prolonged transport and storage time the drift can be higher during the first weeks of operation.
Sensitivity Drift	≤ 0.1 Vol.-% O ₂ per week or ≤ 1 % of measurement value per week (not cumulative), whichever is smaller.
Output Signal Variations	≤ 0.5 % of smallest measurement range span at 2 σ and electronic T90 time (static/dynamic) = 3/0 s
Detection Limit	≤ 0.5 % of span

Influence Effects

Flow Effect	Flow rate in the 20–60 l/h range: ≤ 0.1 Vol.-% O ₂
Associated Gas Effect	The effect of associated gases as a shift of the zero-point – expressed in Vol.-% O ₂ – can be estimated using the approximate values in the following table:

Associated Gas Concentration	100 Vol.-%	Zero-Point Shift
Hydrogen	H ₂	+0.28 Vol.-% O ₂
Argon	Ar	-0.26 Vol.-% O ₂
Helium	He	+0.30 Vol.-% O ₂
Neon	Ne	+0.13 Vol.-% O ₂
Nitrogen	N ₂	±0 Vol.-% O ₂
Nitrogen Oxide	NO	+43 Vol.-% O ₂
Nitrogen Dioxide	NO ₂	+28 Vol.-% O ₂
Nitrous Oxide	N ₂ O	-0.20 Vol.-% O ₂
Carbon Monoxide	CO	-0.01 Vol.-% O ₂
Carbon Dioxide	CO ₂	-0.32 Vol.-% O ₂
Ethane	C ₂ H ₆	-0.46 Vol.-% O ₂
Ethylene	C ₂ H ₄	-0.29 Vol.-% O ₂
Methane	CH ₄	-0.24 Vol.-% O ₂
Propane	C ₃ H ₈	-0.98 Vol.-% O ₂
Propylene	C ₃ H ₆	-0.55 Vol.-% O ₂

EL1020-O2 Oxygen Analyzer

Influence Effects

Temperature Effect	Ambient temperature in the range +5 to +50 °C: At zero-point: ≤ 0.02 Vol.-% O ₂ per 10 °C On sensitivity: ≤ 0.2 % of measurement value per 10 °C
Air Pressure Effect	At zero-point: No effect On sensitivity with no pressure correction: ≤ 1 % of measured value per 1 % air pressure change The air pressure at the installation site can be adjusted manually in the analyzer. On sensitivity with automatic pressure correction using integrated pressure sensor (for measurement ranges with suppressed zero point): ≤ 0.01 % of measurement value per 1 % pressure change or ≤ 0.002 Vol.-% O ₂ per 1 % pressure change, whichever is greater Pressure sensor working range: $p_{abs} = 600-1250$ hPa
Power Supply Effect	Voltage and frequency in permissible range: ≤ 0.2 % of span
Position Effect	Zero-point shift ≤ 0.05 Vol.-% O ₂ per 1° deviation from horizontal location. Position has no effect on the hard-mounted unit.

Dynamic Response

Warm-Up Time	≤ 1 hour
T ₉₀ Time	T ₉₀ ≤ 5 s at a sample gas flow of 60 l/h and electronic T90 time (static/dynamic) = 3/0 sec, gas change from N ₂ to air

Materials in Contact with the Sample Medium

Analyzer (Sample Chamber)	Stainless steel 1.4305, glass, platinum, rhodium, epoxy resin
Gas Lines and Connectors	FPM (Viton), PP, PVDF; in the version for measuring flammable gases: Stainless steel 1.4571

Gas Inlet Conditions

Temperature	+5 to +50 °C The sample gas dew point should be at least 5 °C below the ambient temperature throughout the sample gas path. Otherwise a sample gas cooler or condensate trap is required.
Inlet Pressure	$p_e = 2-100$ hPa (maximum $p_e = 1000$ hPa) Lower pressures require a sample gas pump and higher pressures require a pressure reducer.
Outlet Pressure	Atmospheric pressure
Flow Rate	20-60 l/h
Pressure Drop	< 2 hPa at 60 l/h N ₂
Corrosive Gases	Consultation with ABB Analytical is required if the sample gas contains Cl ₂ , HCl, HF, NH ₃ or other corrosive components.
Flammable Gases	In the version with gas lines and connectors made of stainless steel the analyzer is suitable for measuring flammable gases. Please observe the special conditions on page 8.

Installation Site Requirements

Vibration	max. ± 0.04 mm at 5-20 Hz
Ambient Temperature	Operation: +5 to +50 °C Storage and transport: -25 to +65 °C
Relative Humidity	Operation: < 75 %

EL1020-TC Thermal Conductivity Gas Analyzer

Measurement Principle

Difference in thermal conductivity of various gases
Micromechanical silicon sensor with especially short T_{90} time

Sample Components and Smallest Measurement Ranges

N ₂ in Ar	0– 6 Vol.-%	94–100 Vol.-%
Ar in N ₂	0– 6 Vol.-%	94–100 Vol.-%
Air in CO ₂	0–10 Vol.-%	90–100 Vol.-%
CO ₂ in air	0–10 Vol.-%	90–100 Vol.-%
N ₂ in CO ₂	0–10 Vol.-%	90–100 Vol.-%
CO ₂ in N ₂	0–10 Vol.-%	90–100 Vol.-%
N ₂ in CH ₄	0– 6 Vol.-%	94–100 Vol.-%
CH ₄ in N ₂	0– 6 Vol.-%	94–100 Vol.-%
Air in He	0– 3 Vol.-%	99–100 Vol.-%
He in air	0– 1 Vol.-%	97–100 Vol.-%
Ar in He	0– 3 Vol.-%	99–100 Vol.-%
He in Ar	0– 1 Vol.-%	97–100 Vol.-%
N ₂ in He	0– 3 Vol.-%	99–100 Vol.-%
He in N ₂	0– 1 Vol.-%	97–100 Vol.-%
Ar in H ₂	0– 3 Vol.-%	99–100 Vol.-%
H ₂ in Ar	0– 1 Vol.-%	97–100 Vol.-%
CO ₂ in H ₂	0– 3 Vol.-%	99–100 Vol.-%
H ₂ in CO ₂	0– 1 Vol.-%	97–100 Vol.-%
CH ₄ in H ₂	0– 3 Vol.-%	99–100 Vol.-%
H ₂ in CH ₄	0– 1 Vol.-%	97–100 Vol.-%
N ₂ in H ₂	0– 3 Vol.-%	99–100 Vol.-%
H ₂ in N ₂	0– 1 Vol.-%	97–100 Vol.-%
Ar in O ₂	0–10 Vol.-%	90–100 Vol.-%
O ₂ in Ar	0–10 Vol.-%	90–100 Vol.-%
H ₂ in air	0– 1 Vol.-%	–
Air in H ₂	0– 1 Vol.-%	–

From these measurement components (gas mixtures) one component can be selected.

Measurement Range Data

Quantity	1 measurement range
	The measurement range is freely adjustable. It is factory-set to relative thermal conductivity (rTC) = 0–60,000.
Largest Measurement Range	0 to 100 Vol.-% or 0 Vol.-% to saturation, depending on measurement task
Limit Value Monitoring	2 limit values

Calibration

Zero-Point Calibration	With test gas or measurement component-free process gas
End-Point Calibration	With test gas or process gas having a known sample gas concentration
Measurement Ranges with Suppressed Zero-Point	Zero-point and end-point should only be calibrated with test gases with concentrations in the selected measurement range.

Note

The following measurement data relate to the gas mixtures given in the table. Compliance with these data when measuring other gas mixtures can only be assured if their composition is known and ABB Analytical has verified that the analyzer is suitable for the measurement task.

Stability

The following data apply only if all influence factors (e.g. flow rate, temperature, atmospheric pressure) are constant. They relate to smallest measurement ranges given in the table. The deviations may be larger for smaller measurement ranges.

Linearity Deviation	≤ 2 % of span
Repeatability	≤ 1 % of span
Zero Drift	≤ 2 % of smallest given measurement range per week
Sensitivity Drift	≤ 0.5 % of smallest given measurement range per week
Output Signal Variations	≤ 0.5 % of smallest measurement range span at 2 σ and electronic T90 time = 0 sec
Detection Limit	≤ 0.5 % of span

Influence Effects

The following data relate to smallest measurement ranges given in the table. The influence effects may be larger for smaller measurement ranges. The influence effects will be larger at operating altitudes > 2000 meters.

Flow Effect	≤ 0.5 % of span at a flow change of ±10 l/h within detection limit for equal flow rates of sample and test gas
Associated Gas Effect	If the sample gas contains components in addition to the sample component (binary gas mixture), this will result in erroneous measurements.
Temperature Effect	Ambient temperature in the range +5 to +50 °C: At each point in the measurement range: ≤ 0.5 % of span per 10 °C, based on temperature at the time of calibration. Thermostat temperature = 60 °C

EL1020-TC Thermal Conductivity Gas Analyzer

Influence Effects

Air Pressure Effect	≤ 0.25 % of span per 10 hPa for the smallest possible ranges given; for larger spans the effect is correspondingly lower. Pressure sensor working range: $p_{\text{abs}} = 600\text{--}1250$ hPa
Power Supply Effect	Voltage and frequency in permissible range: ≤ 0.2 % of span
Position Effect	< 1 % of span up to 30° deviation from horizontal orientation

Dynamic Response

Warm-Up Time	Approx. 30 minutes
T_{90} Time	$T_{90} \leq 2$ s for sample gas flow of 60 l/h

Materials in Contact with the Sample Medium

Analyzer (Sample Chamber)	Sensor: Gold, silicon oxo-nitride; Sample chamber: Stainless steel 1.4305
Gas Lines and Connectors	FPM (Viton), PP, PVDF; in the version for measuring flammable gases: Stainless steel 1.4571

Gas Inlet Conditions

Temperature	+5 to +50 °C The sample gas dew point should be at least 5 °C below the ambient temperature throughout the sample gas path. Otherwise a sample gas cooler or condensate trap is required.
Inlet Pressure	$p_e = 2\text{--}100$ hPa (maximum $p_e = 1000$ hPa) Lower pressures require a sample gas pump and higher pressures require a pressure reducer.
Outlet Pressure	Atmospheric pressure
Flow Rate	Normally 10–90 l/h, minimum 1 l/h
Pressure Drop	< 2 hPa at 60 l/h N_2
Corrosive Gases	The analyzer should not be used for measurements in corrosive associated gas components. Consultation with ABB Analytical may be required.
Flammable Gases	In the version with gas lines and connectors made of stainless steel the analyzer is suitable for measuring flammable gases. Please observe the special conditions on page 8.

Installation Site Requirements

Vibration	max. ± 0.04 mm at 5 to 55 Hz, 0.5 g at 55 to 150 Hz
Ambient Temperature	Operation: +5 to +50 °C Storage and transport: –25 to +65 °C
Relative Humidity	Operation: < 75 %

General Specifications

Housing

Version	1/2 19 inch housing for desktop and rack mounting
Housing Protection Type	IP 20 per EN 60529
Housing Material	Base support: Aluminum sheet Cover: Steel sheet
Housing Color	Light gray (RAL 7035), basalt gray (RAL 7012)
Dimensions	see dimensional drawing, page 9
Weight	Approx. 8 kg

Display and Operation

Display	Illuminated LC Display with 2 x 20 characters
Readout Resolution	Better than 0.2 % of measurement span
Operation	Four keys: Up, Down, Enter, Back

Electrical Safety

Tested per EN 61010-1	
Protection Class	I
Overload Category	Power supply: II Signal inputs and outputs: II
Pollution Level	2
Safe Isolation	The power supply is galvanically isolated from other circuits by means of reinforced or double insulation. Operational low voltage (PELV) on low-voltage side

Electromagnetic Compatibility

Noise Immunity	Tested per EN 61000-6-2
RF Suppression	Class B per EN 55011

Mechanical Stress

In its original packaging, the analyzer will withstand normal shipping conditions, e.g. as found in rail transport.

Measurement of Flammable Gases

Expert Opinion Statement	TÜV Süddeutschland Bau und Betrieb GmbH No. BB-EG1-MAN/02-47
Special Conditions	The sample gas lines in the gas analyzer must be designed in the form of stainless steel pipes. The tightness of the sample gas feed path must be checked regularly. Housing purge is not required. One of the openings for the hose fittings must be open and sufficiently ventilated. If the gas analyzer is fitted in a rack, a natural exchange of air with the environment must be possible. If the gas analyzer is fitted in an enclosed cabinet, adequate external ventilation must be provided. Before using the gas analyzer the corrosion resistance against the specific sample gas must be checked. In case of failure the pressure in the containment system must not exceed the maximum value $p_e = 500$ hPa (EL1020-IR) or $p_e = 1000$ hPa (EL1020-O2 and EL1020-TC).

Interfaces and Electrical Connections

see connection drawing, page 10

Gas Connections

see connection drawing, page 10

Power Supply

Input Voltage	85–250 VAC, 48–63 Hz
Power Consumption	EL1020-IR: max. 40 VA, EL1020-O2: max. 90 VA, EL1020-TC: max. 40 VA
Connection	3-pin plug per EN 60320/C14 Connecting cable supplied

Dimensional Drawing

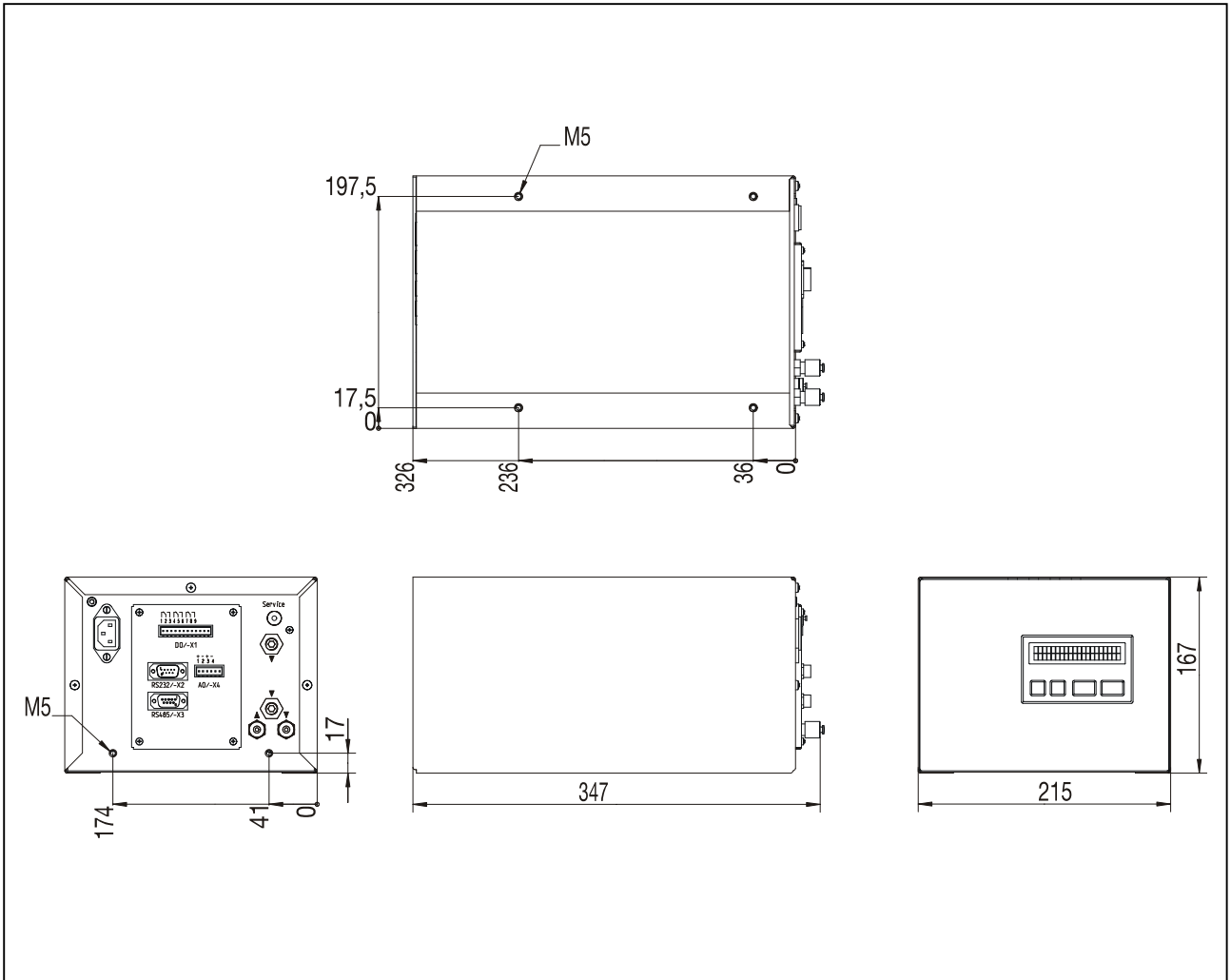

Connection Drawing

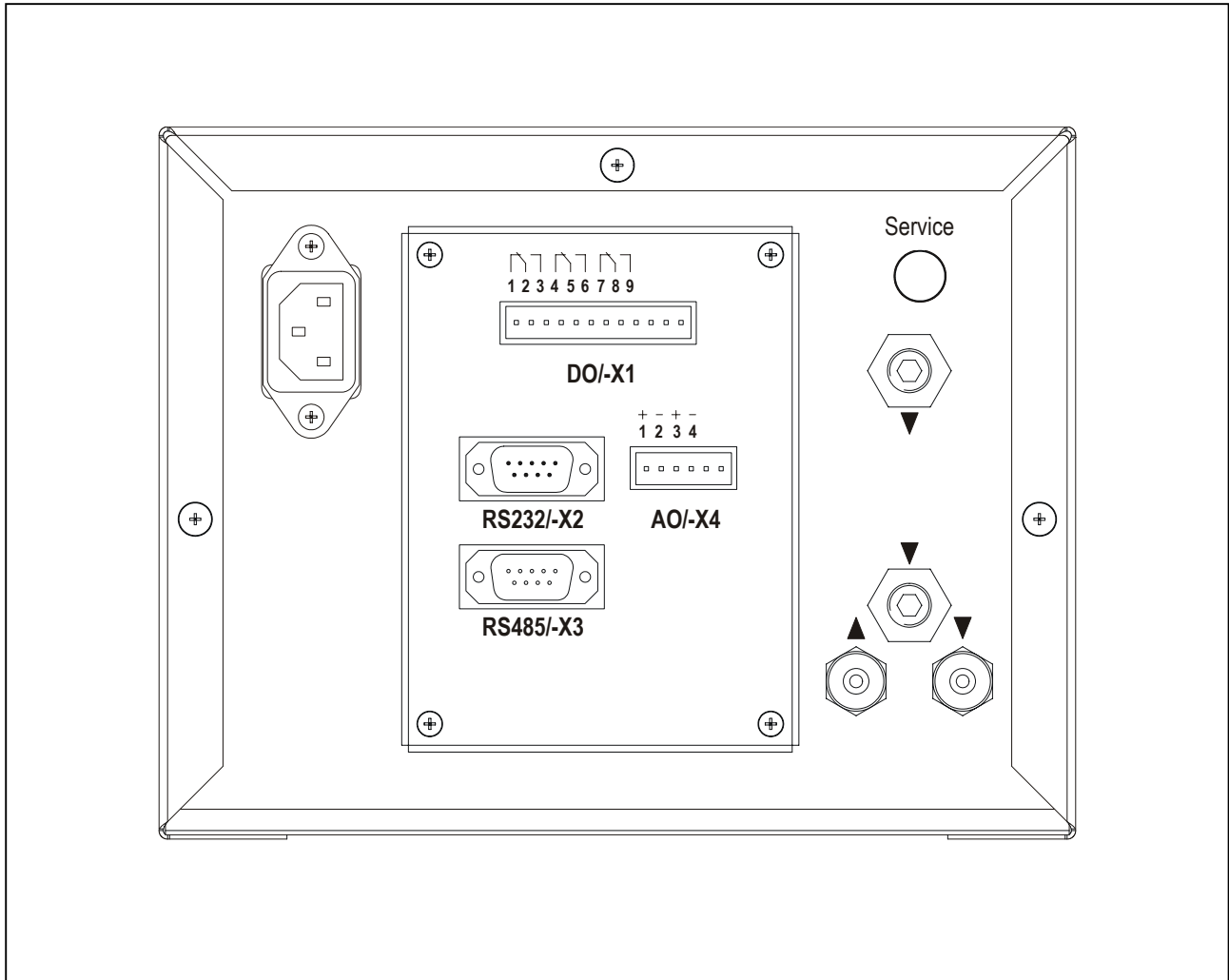

Digital Outputs
DO/-X1

2 alarm value signals,
1 collective status signal

Floating double-throw contacts, max. contact load rating 30 VDC / 1 A

Design:
Terminal strip for braided or solid conductors with a maximum section of 1.5 mm² (16 AWG)

Relays are shown in the unpowered state. The unpowered state is the failure mode.

Serial Interface
RS232/-X2
RS485/-X3

RS485 or RS232 interface (configurable)

Transfers sample values and status signals to host systems, e.g. to standard Windows applications via Modbus DDE-Server

Modbus slave protocol in RTU (remote terminal unit) mode

Design:
RS485: 9-pin female Sub-D plug
RS232: 9-pin male Sub-D plug

Analog Outputs
AO/-X4

1 output 4 to 20 mA per sample component, common negative pole, galvanically isolated from ground, freely connectable to ground, max. gain relative to protective ground potential 50 V, max. working resistance 750 Ω

The output signal cannot be lower than 0 mA.

Design:
Terminal strip for braided or solid conductors with a maximum section of 1.5 mm² (16 AWG)

Sample Gas Ports
Couplings for hose
DN 4/6

or

Couplings with 1/8 NPT internal threads in the version for measuring flammable gases

Sample Gas Inlet **Sample Gas Outlet**

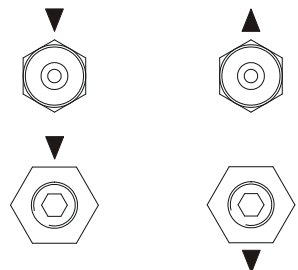

The Industrial^{IT} word mark and all mentioned product names in the form XXXXX^{IT} are registered or pending trademarks of ABB.

ABB has Sales & Customer Support expertise in over 100 countries worldwide.

www.abb.com



ABB Automation Products GmbH

Analytical Division
Stierstaedter Strasse 5
D-60488 Frankfurt am Main
Phone: +49 69 7930-40
Fax: +49 69 7930-4566
E-Mail: analytical-mkt.deapr@de.abb.com

The Company's policy is one of continuous product improvement and the right is reserved to modify the information contained herein without notice.

Printed in the Fed. Rep. of Germany (09.03)

© ABB 2003