

## 2600T Series Pressure Transmitters

Model 265GR Gauge  
Model 265AR Absolute  
with remote seal



**Base accuracy :  $\pm 0.04\%$**

- **Span limits**
  - 6 to 60000kPa; 24inH<sub>2</sub>O to 8700psi
  - 6 to 3000kPa abs; 45mmHg to 435psia
- **Reliable sensing system coupled with very latest digital technologies**
- **Comprehensive sensor choice**
  - optimize in-use total performance and stability
- **5-year stability**
- **Flexible configuration facilities**
  - provided locally via local keys combined with LCD indicator or via hand held terminal or PC configuration platform
- **Multiple protocol availability**
  - provides integration with HART®, PROFIBUS PA and FOUNDATION Fieldbus platforms offering interchangeability and transmitter upgrade capabilities
- **Broad selection of variants, options fill fluids and wetted materials**
  - allows totale flexibility maximizing cost-effective aspect, also providing applications with critical process media at extended temperature range
- **Full compliance with PED category III**



**ABB 2600T Series  
Engineered solutions  
for all applications**

## General description

Models detailed in this data sheet apply for those transmitters which include one remote seal connected via a capillary to the transmitter sensor.

Refer of seal data sheet SS/S265 for all data and details relevant to seal element.

## Functional Specifications

### Range and span limits

Sensor Code	Upper Range Limit (URL)	Lower Range Limit (LRL) (*)	Overrange Limit	Minimum Span				
				Flush Diaphragm DN25 / 1in	Flush Diaphragm DN50 / 2in	Flush Diaphragm DN80 / 3in	Extended Diaphragm DN50 / 2in	Extended Diaphragm DN80 / 3in
				max. 250bar 25MPa, 3625psi	max. 100bar 10MPa, 1450psi	max. 100bar 10MPa, 1450psi	max. 100bar 10MPa, 1450psi	max. 100bar 10MPa, 1450psi
				max.length of capillary tube 6m	max.length of capillary tube 16m	max.length of capillary tube 16m	max.length of capillary tube 16m	max.length of capillary tube 16m
<b>C</b>	6kPa 60mbar 24inH <sub>2</sub> O	-6kPa -60mbar -24inH <sub>2</sub> O	1MPa 10bar 145psi			6kPa 60mbar 24inH <sub>2</sub> O		6kPa 60mbar 24inH <sub>2</sub> O
<b>F</b>	40kPa 400mbar 160inH <sub>2</sub> O	-40kPa -400mbar -160inH <sub>2</sub> O	1MPa 10bar 145psi	16kPa 160mbar 64inH <sub>2</sub> O	10kPa 100mbar 40inH <sub>2</sub> O	6kPa 60mbar 24inH <sub>2</sub> O	16kPa 160mbar 64inH <sub>2</sub> O	6kPa 60mbar 24inH <sub>2</sub> O
<b>L</b>	250kPa 2500mbar 1000inH <sub>2</sub> O	-100kPa -1000mbar -400inH <sub>2</sub> O	500kPa 5bar 72.5psi	16kPa 160mbar 64inH <sub>2</sub> O	10kPa 100mbar 40inH <sub>2</sub> O	6kPa 60mbar 24inH <sub>2</sub> O	16kPa 160mbar 64inH <sub>2</sub> O	6kPa 60mbar 24inH <sub>2</sub> O
<b>U</b>	3000kPa 30bar 435psi	-100kPa -1bar -14.5psi	6MPa 60bar 870psi	100kPa 1bar 14.5psi	100kPa 1bar 14.5psi	100kPa 1bar 14.5psi	100kPa 1bar 14.5psi	100kPa 1bar 14.5psi
<b>R</b>	10MPa 100bar 1450psi	-100kPa -1bar -14.5psi	20MPa 200bar 2900psi	333kPa 3.3bar 47.8psi	333kPa 3.3bar 47.8psi	333kPa 3.3bar 47.8psi	333kPa 3.3bar 47.8psi	333kPa 3.3bar 47.8psi
<b>V</b>	60MPa 600bar 8700psi	-100kPa -1bar -14.5psi	90MPa 900bar 13050psi	2kPa 20bar 290psi	2MPa 20bar 290psi	2MPa 20bar 290psi	2MPa 20bar 290psi	2MPa 20bar 290psi
<b>F</b>	40kPa 400mbar abs 160inH <sub>2</sub> O	0kPa 0mbar abs 0inH <sub>2</sub> O	1MPa 10bar 145psi	16kPa 160mbar 64inH <sub>2</sub> O	10kPa 100mbar 40inH <sub>2</sub> O	6kPa 60mbar 24inH <sub>2</sub> O	16kPa 160mbar 64inH <sub>2</sub> O	6kPa 60mbar 24inH <sub>2</sub> O
<b>L</b>	250kPa 2500mbar abs 1000inH <sub>2</sub> O	0kPa 0mbar abs 0inH <sub>2</sub> O	500kPa 5bar 72.5psi	16kPa 160mbar 64inH <sub>2</sub> O	10kPa 100mbar 40inH <sub>2</sub> O	6kPa 60mbar 24inH <sub>2</sub> O	16kPa 160mbar 64inH <sub>2</sub> O	6kPa 60mbar 24inH <sub>2</sub> O
<b>U</b>	3000kPa 30bar abs 435psia	0kPa 0mbar abs 0psia	6MPa 60bar 870psi	150kPa 1.5bar 21.7psi	150kPa 1.5bar 21.7psi	150kPa 1.5bar 21.7psi	150kPa 1.5bar 21.7psi	150kPa 1.5bar 21.7psi

Sensor Code	Upper Range Limit (URL)	Minimum Span			
		In-Line remote seal DN25 / 1in	In-Line remote seal DN40 / 1 1/2in	In-Line remote seal DN50 / 2in	In-Line remote seal DN80 / 3in
		max. 250bar 25MPa, 3625psi	max. 250bar 25MPa, 3625psi	max. 250bar 25MPa, 3625psi	max. 250bar 25MPa, 3625psi
		max.length of capillary tube 4m	max.length of capillary tube 6m	max.length of capillary tube 8m	max.length of capillary tube 16m
<b>C</b>	6kPa 60mbar 24inH <sub>2</sub> O				
<b>F</b>	40kPa 400mbar 160inH <sub>2</sub> O				
<b>L</b>	250kPa 2500mbar 1000inH <sub>2</sub> O				
<b>U</b>	3000kPa 30bar 435psi	400kPa 4bar 58psi	250kPa 2.5bar 36.3psi	250kPa 2.5bar 36.3psi	250kPa 2.5bar 36.3psi
<b>R</b>	10MPa 100bar 1450psi	400kPa 4bar 58psi	333kPa 3.3bar 47.8psi	333kPa 3.3bar 47.8psi	333kPa 3.3bar 47.8psi
<b>V</b>	60MPa 600bar 8700psi	2MPa 20bar 290psi	2MPa 20bar 290psi	2MPa 20bar 290psi	2MPa 20bar 290psi
<b>F</b>	40kPa 400mba abs 160inH <sub>2</sub> O				
<b>L</b>	250kPa 2500mbar abs 1000inH <sub>2</sub> O				
<b>U</b>	3000kPa 30bar abs 435psia	400kPa 4bar 58psi	250kPa 2.5bar 36.3psi	250kPa 2.5bar 36.3psi	250kPa 2.5bar 36.3psi

### Span limits

Maximum span = URL

IT IS RECOMMENDED TO SELECT THE TRANSMITTER SENSOR CODE PROVIDING THE TURNDOWN VALUE AS LOWEST AS POSSIBLE TO OPTIMIZE PERFORMANCE CHARACTERISTICS.

### Zero suppression and elevation

Zero and span can be adjusted to any value within the range limits detailed in the table as long as:

– calibrated span  $\geq$  minimum span

### Damping

Adjustable time constant : 0 to 60s.

This is in addition to sensor response time

### Turn on time

Operation within specification in less than 2.5s with minimum damping.

### Insulation resistance

> 100M $\Omega$  at 1000VDC (terminals to earth)

## Operative limits

### Temperature limits °C (°F) :

#### Ambient (is the operating temperature)

Silicone oil filling: -40°C and +85°C (-40°F and +185°F)

Inert filling: -20°C and +85°C (-4°F and +185°F)

Note : For Hazardous Atmosphere applications see the temperature range specified on the certificate/approval relevant to the aimed type of protection.

#### Process

The following table show characteristics of capillary/seal fill fluids when used in transmitters with remote seal.

Filling Liquid	Id	Density at 20° C in Kg/m	Process temperature in° C (° F)
Silicone oil	IC	1055	-30 and +250 (-22 and +482)
Carbon Fluoride	L	1880	-30 and +150 (-22 and +302)
High-temperature Oil	IH	1070	-10 and +400 (+14 and +752)
White Oil	WB	849	-10 and +200 (+14 and +392)
Vacuumproof Design	IC-V	1055	-30 and +200 (-22 and +392)

Flush diaphragm DN25 / 1in: max +250°C (482°F)

Flush diaphragm, material tantalum: max +220°C (428°F)

In-line remote seal DN25 / 1in : max +250°C (482°F)

#### Storage

Lower limit: -50°C (-58°F); -40°C (-40°F) for LCD indicators

Upper limit: +85°C (+185°F)

## Pressure limits

For maximum pressure refer to sensor overrange limit and seal working pressure in table "Range and Span limits" at pages 2 and 3.

For minimum pressure refer to the following table:

Filling Liquid	Id	Pressure rating in mbar abs.					
		20° C (68° F)	100° C (212° F)	150° C (302° F)	200° C (392° F)	250° C (482° F)	400° C (752° F)
Silicone oil	IC	> 500	> 500	> 500	> 750	> 1000	
Carbon Fluoride	L	> 1000	> 1000	> 1000			
High-temperature	IH	> 500	> 500	> 500	> 750	> 1000	> 1000
White Oil	WB	> 500	> 1000	> 1000	> 1000	> 1000	
Vacuumproof Design	IC-V	> 5	> 25	> 38	> 50		

#### Overpressure limits

##### (without damage to the transmitter)

The transmitter can be exposed without leaking to line pressure up to the overrange limit of the sensor or 2 times the flange rating of seal, whichever is less.

**Environmental limits**

**Electromagnetic compatibility (EMC)**

Definition Class 3  
 Radio suppression Limit class B (according to EN 550011)  
 Fulfills NAMUR recommendation

**Low voltage directive**

Comply with 73/23/EEC

**Pressure equipment directive (PED)**

Comply with 97/23/EEC Category III module H.

**Humidity**

Relative humidity: up to 100% annual average  
 Condensing, icing: admissible

**Vibration resistance**

Accelerations up to 2g at frequency up to 1000Hz (according to IEC 60068–2–26)

**Shock resistance (according to IEC 60068–2–27)**

Acceleration: 50g  
 Duration: 11ms

**Wet and dust-laden atmospheres**

The transmitter is dust and sand tight and protected against immersion effects as defined by IEC EN60529 (1989) to IP 67 (IP 68 on request) or by NEMA to 4X or by JIS to C0920.

**Hazardous atmospheres**

– Transmitters of the type of protection "Intrinsically safe EEx ia" according to the directions 94 / 9 / EC (ATEX)  
Transmitter with 4 to 20mA output signal and HART communication  
 Marking (DIN EN 50 014): II 1/2 GD T50°C EEx ia IIC T6 or resp. II 1/2 GD T95°C EEx ia IIC T4

Supply and signal circuit type of protection Intrinsic Safety EEx ib IIB/IIC resp. EEx ia IIB/IIC  
 for connection to supply units with maximum values:  
 II 1/2 GD T50°C EEx ia resp. ib IIC T6 resp.  
 II 1/2 GD T95°C EEx ia resp. ib IIC T4  
 for Temperature class T4 resp. T95°C:  
 $U_i = 30V$   
 $I_i = 200mA$   
 $P_i = 0.8W$  for T4 with  $T_a = (-40 \text{ to } +85)^\circ C / (-40 \text{ to } +185)^\circ F$   
 $P_i = 1.0W$  for T4 with  $T_a = (-40 \text{ to } +70)^\circ C / (-40 \text{ to } +158)^\circ F$   
 for Temperature class T6 resp. T50°C:  
 $P_i = 0.7W$  for T6 with  $T_a = (-40 \text{ to } +40)^\circ C / (-40 \text{ to } +104)^\circ F$   
 effective internal capacitance,  $C_i \leq 10nF$   
 effective internal inductance, negligible.

The capacitive measuring element (range code C, F) supplied with an intrinsically safe circuit EEx ib IIB/IIC must not be mounted into the separation wall between category 1G and category 2G.

Fieldbus transmitters (PROFIBUS PA / FOUNDATION Fieldbus)  
 Marking (DIN EN 50 014): II 1/2 GD T50°C EEx ia IIC T6 or resp. II 1/2 GD T95°C EEx ia IIC T4

Supply and signal circuit type of protection Intrinsic Safety EEx ib IIB/IIC resp. EEx ia IIB/IIC  
 for connection to FISCO supply units with rectangular or trapezoidal characteristics with maximum values:

II 1/2 G EEx ia respectively ib IIC T4/T6  $U_i = 17.5V$   
 $I_i = 360mA$   
 $P_i = 2.52W$   
 II 1/2 G EEx ia respectively ib IIB T4/T6  $U_i = 17.5V$   
 $I_i = 380mA$   
 $P_i = 5.32W$

resp. for connection to supply unit or barrier with linear characteristics with maximum values:

II 1/2 G EEx ia respectively ib IIC T4/T6  $U_i = 24V$   
 $I_i = 250mA$   
 $P_i = 1.2W$

effective internal inductance  $L_i \leq 10 \mu H$ ,  
 effective internal capacitance  $C_i \approx 0$   
 Maximum permissible ambient temperatures depending on the temperature class:

T4:  $-40^\circ C$  to  $+85^\circ C$  ( $-40^\circ F$  to  $+185^\circ F$ )  
 T5, T6:  $-40^\circ C$  to  $+40^\circ C$  ( $-40^\circ F$  to  $+104^\circ F$ )

The capacitive measuring element (range code C, F) supplied with an intrinsically safe circuit EEx ib IIB/IIC must not be mounted into the separation wall between category 1G and category 2G.

– Transmitters of the type of protection "flameproof enclosure EEx d" according to the directions 94 / 9 / EC (ATEX)

Transmitter with 4 to 20mA output signal and HART communication and Fieldbus transmitters (PROFIBUS PA / FOUNDATION Fieldbus)  
 Marking (DIN EN 50 014): II 1/2 G EEx d IIC T6  
 Ambient temperature range:  $-40^\circ C$  to  $+75^\circ C$  ( $-40^\circ F$  to  $+167^\circ F$ )

– Transmitters of category 3 for the application in "Zone 2"

Transmitter with 4 to 20mA output signal and HART communication  
 according to the directions 94 / 9 / EC (ATEX)  
 Marking (DIN EN 50 014): II 3 GD T50°C EEx nL IIC T6 or resp. II 3 GD T95°C EEx nL IIC T4

Operating conditions:  
 Supply and signal circuit (terminals signal +/-):  $U \leq 45V$   
 $I \leq 22.5mA$

Ambient temperature range:  
 Temperature class T4  $T_a = -40^\circ C$  to  $+85^\circ C$  ( $-40^\circ F$  to  $+185^\circ F$ )  
 Temperature class T5, T6  $T_a = -40^\circ C$  to  $+40^\circ C$  ( $-40^\circ F$  to  $+104^\circ F$ )

– Factory Mutual (FM)

Transmitter with 4 to 20mA output signal and HART communication  
 Intrinsically safe: Class I; Division 1; Groups A, B, C, D; Class I; Zone 0; Group IIC; AEx ia IIC  
 Degree of protection : NEMA Type 4X (indoor or outdoor)

Permissible ambient temperature depending on temperature class

<b><math>U_{max} = 30V, C_i = 10.5nF, L_i = 10\mu H</math></b>			
Ambient Temperature	Temperature class	$I_{max}$	$P_i$
$-40$ to $+85^\circ C$ ( $-40$ to $+185^\circ F$ )	T4	200mA	0.8W
$-40$ to $+70^\circ C$ ( $-40$ to $+129^\circ F$ )	T4	200mA	1W
$-40$ to $+40^\circ C$ ( $-40$ to $+104^\circ F$ )	T5	25mA	0.75W
$-40$ to $+40^\circ C$ ( $-40$ to $+104^\circ F$ )	T6	25mA	0.5W

Fieldbus transmitters (PROFIBUS PA/FOUNDATION Fieldbus)

Intrinsically Safe : Class I, II and III; Division 1; Groups A, B, C, D, E, F, G;  
 Class I; Zone 0, AEx ia Group IIC T6; T4  
 Non-incendive Class I, II and III, Division 2; Groups A, B, C, D, F, G

Transmitter with 4 to 20mA output signal and HART communication and Fieldbus transmitters (PROFIBUS PA/FOUNDATION Fieldbus)

Explosion-Proof: Class I; Division 1; Groups A, B, C, D; Class II/III, Division 1; Groups E, F, G  
 Degree of protection : NEMA Type 4X (indoor or outdoor)

– Canadian Standard (CSA)

Transmitter with 4 to 20mA output signal and HART communication and Fieldbus transmitters (PROFIBUS PA/FOUNDATION Fieldbus)

Explosion-Proof: Class I; Division 1; Groups B, C, D  
 Class II; Division 1; Groups E, F, G  
 Class III  
 Degree of protection : NEMA Type 4X (indoor or outdoor)

## Electrical Characteristics and Options

### HART digital communication and 4 to 20mA output

#### Power Supply

The transmitter operates from 10.5 to 45VDC with no load and is protected against reverse polarity connection (additional load allows operations over 45VDC).

Minimum power supply is 14VDC with backlit indicator.

For EEx ia and other intrinsically safe approval power supply must not exceed 30VDC.

#### Ripple

Maximum permissible voltage ripple of power supply during the communication:

7Vpp at f = 50 to 100Hz

1Vpp at f = 100 to 200Hz

0.2Vpp at f = 200 to 300Hz

#### Load limitations

4 to 20mA and HART total loop resistance :

$$R(\text{k}\Omega) = \frac{\text{Supply voltage} - \text{min. operating voltage (VDC)}}{22.5 \text{ mA}}$$

A minimum of 250Ω is required for HART communication.

## Optional indicators

### Integral display

2-line, 6-character 19-segment alphanumeric display with additional bar chart display, optionally with back illumination. User-specific display:

percentage of the output current or

output current in mA or

free process variable

Diagnostic message, alarms, measuring range infringements and changes in the configuration are also displayed.

### Optional surge protection

Up to 4kV

- voltage 1.2μs rise time / 50μs delay time to half value

- current 8μs rise time / 20μs delay time to half value

### Output signal

Two-wire 4 to 20mA, user-selectable for linear or freely programmable with 20 reference points output.

HART® communication provides digital process variable (% , mA or engineering units) superimposed on 4 to 20mA signal, with protocol based on Bell 202 FSK standard.

### Output current limits (to NAMUR standard)

Overload condition

- Lower limit: 3.8mA (configurable down to 3.5mA)

- Upper limit: 20.5mA (configurable up to 22.5mA)

### Alarm current

Min. alarm current: configurable from 3.5mA to 4mA,  
standard setting: 3.6mA

Max. alarm current: configurable from 20mA to 22.5mA,  
standard setting: 21mA

Standard setting: max. alarm current

## PROFIBUS PA output

### Device type

Pressure transmitter compliant to Profile 3.0 Class A & B; ident. number 04C2 HEX.

### Power supply

The transmitter operates from 10.2 to 32VDC with no polarity.

For EEx ia approval power supply must not exceed 17.5VDC. Intrinsic safety installation according to FISCO model.

### Current consumption

operating (quiescent): 11.7mA

fault current limiting: 17.3mA max.

### Output signal

Physical layer in compliance to IEC 1158-2/EN 61158-2 with transmission to Manchester II modulation, at 31.25kbit/sec.

### Output interface

PROFIBUS PA communication according to Profibus DP50170 Part 2/ DIN 19245 part 1-3.

### Output update time

40ms

### Function blocks

1 Analog Input, 1 Transducer, 1 Physical

### Integral display

2-line, 6-character 19-segment alphanumeric display with additional bar chart display, optionally with back illumination. User-specific display:

percentage of the output or

OUT (analog input function block)

Diagnostic message, alarms, measuring range infringements and changes in the configuration are also displayed.

### Transmitter failure mode

Permanent self-diagnostic; possible errors indicated in diagnostic parameters and in the status of process values.

## FOUNDATION Fieldbus output

### Power supply

The transmitter operates from 10.2 to 32VDC polarity independent.

For EEx ia approval power supply must not exceed 24VDC (entity certification) or 17.5VDC (FISCO certification), according to FF-816.

### Current consumption

operating (quiescent): 11.7mA

fault current limiting: 17.3mA max.

### Output signal

Physical layer in compliance to IEC 1158-2/EN 61158-2 with transmission to Manchester II modulation, at 31.25kbit/sec.

### Function blocks/execution period

1 standard Analog Input block/25ms max

1 PID function block

### Additional blocks

1 custom Pressure with calibration Transducer block

1 enhanced Resource block

### Number of link objects

10

### Number of VCRs

16

### Output interface

FOUNDATION fieldbus digital communication protocol to standard H1, compliant to specification V. 1.5; FF registration in progress.

### Integral display

2-line, 6-character 19-segment alphanumeric display with additional bar chart display, optionally with back illumination. User-specific display:

percentage of the output or

OUT (analog input)

Diagnostic message, alarms, measuring range infringements and changes in the configuration are also displayed.

### Transmitter failure mode

Permanent self-diagnostic; possible errors indicated in diagnostic parameters and in the status of process values.

## Performance specifications

Stated at reference condition to IEC 60770 ambient temperature of 20°C (68°F), relative humidity of 65%, atmospheric pressure of 1013hPa (1013mbar), zero based range for transmitter with isolating diaphragms ceramic or Hastelloy and silicone oil fill and HART digital trim values equal to 4–20mA span end points, in linear mode.

Unless otherwise specified, errors are quoted as % of span.

Some performance data (based to URL) are affected by the actual turndown (TD) as ratio between Upper Range Limit (URL) and calibrated span.

IT IS RECOMMENDED TO SELECT THE TRANSMITTER SENSOR CODE PROVIDING THE TURNDOWN VALUE AS LOWEST AS POSSIBLE TO OPTIMIZE PERFORMANCE CHARACTERISTICS.

## Accuracy rating

% of calibrated span, including combined effects of terminal based linearity, hysteresis and repeatability.

For fieldbus versions SPAN refer to Analog Input Function Block outscale range

– ±0.04% for TD from 1:1 to 10:1

–  $\pm(0.04 + 0.005 \times \frac{\text{URL}}{\text{Span}} - 0.05)\%$  for TD greater than 10:1

## Operating influences

### Ambient temperature (for turndown up to 15:1)

per 20K (36°F) change between the limits of –20°C to +65°C (–4 to +150°F)

– ±(0.03% URL + 0.05% span)

The total temperature error is the combination of the above transmitter effect with seal errors, as applicable due to application temperatures.

Refer to seal data sheets for additional effects of the remote seal.

### Supply voltage

Within voltage/load specified limits the total effect is less than 0.001% of URL per volt.

### Load

Within load/voltage specified limits the total effect is negligible.

### Radio frequency interference

Total effect : less than 0.05% of span from 20 to 1000MHz and for field strengths up to 10V/m when tested with unshielded conduit, with or without meter.

### Common mode interference

No effect from 250Vrms @ 50Hz, or 50VDC

### Vibration effect

±0.10% of URL (according to IEC 61298–3)

## Physical Specification

(Refer to ordering information sheets for variant availability related to specific model or versions code)

### Materials

#### Process isolating diaphragms (\*)

Refer to ordering information

#### Process connection (\*)

Refer to ordering information

#### Seal fill fluid

Refer to ordering information

#### Sensor fill fluid

Silicone oil; inert fill (Carbon fluoride); white oil (FDA)

#### Mounting bracket

AISI 316 L ss

#### Sensor housing

AISI 316 L ss.

#### Electronic housing and covers

Barrel version

- Low-copper content aluminium alloy with baked epoxy finish;
- AISI 316 L ss.

DIN version

- Low-copper content aluminium alloy with baked epoxy finish.

#### Covers O-ring

Viton™.

#### Local zero and span adjustments:

Glass filled polycarbonate plastic (removable).

No local zero and span adjustments with housing made of stainless steel.

#### Tagging

AISI 316ss or plastic data plate attached to the electronics housing.

### Calibration

Standard: at maximum span, zero based range, ambient temperature and pressure;

Optional: at specified range and ambient conditions; or at operating temperature

### Optional extras

#### Mounting brackets

For vertical and horizontal 60mm. (2in) pipes or wall mounting.

#### Integral display

plug-in rotatable LCD indicator

#### Supplemental customer tag

AISI 316 ss tag fastened to the transmitter with stainless steel wire for customer's tag data up to a maximum of 30 characters and spaces.

#### Surge protection

Available for HART instruments only general purpose and intrinsically safe to ATEX; for PROFIBUS PA and FOUNDATION Fieldbus instruments only general purpose.

#### Cleaning procedure for oxygen service

#### Test Certificates (test, design, calibration, material traceability)

#### Tag and manual language

#### Process connections

Refer to ordering information

#### Electrical connections

Two 1/2 NPT or M20x1.5 threaded conduit entries, direct on housing, or plug connector:

- HART: straight or angle Harting Han 8U connector and one plug.
- PROFIBUS PA, FOUNDATION Fieldbus : M12x1 or 7/8 (without mating female plug)

#### Terminal block

HART version: four terminals for signal/external meter wiring up to 2.5mm<sup>2</sup> (14AWG) and four connection points for test and communication purposes.

Fieldbus versions: two terminals for signal (bus connection) wiring up to 2.5mm<sup>2</sup> (14AWG).

#### Grounding

Internal and external 4mm<sup>2</sup> (12AWG) ground termination points are provided.

#### Mounting position

Transmitter can be mounted in any position.

Electronics housing may be rotated to any position. A positive stop prevents over travel.

#### Mass (without options)

Transmitter: approx 1.2kg

Flange seal

- DN50, PN16/40 with flush diaphragm: approx 3.3kg
- 2in, Class 300 with flush diaphragm: approx 3.7kg
- DN50, PN16/40 with extended diaphragm.100mm: approx 4.0kg
- 2in, Class 300 with extended diaphragm.100mm: approx 5.4kg
- DN80, PN16/40 with flush diaphragm: approx 5.8kg
- 3in, Class 150 with flush diaphragm: approx 5.3kg
- DN80, PN16/40 with extended diaphragm.100mm: approx 7.5kg
- 3in, Class 150 with extended diaphragm.100mm: approx 7.0kg

Flush diaphragm seals DN25/1in, miniature seals, in-line seals and fast coupled seals: see dimensional diagrams.

#### Packing

Carton

## Configuration

### Transmitter with HART communication and 4 to 20 mA

#### Standard configuration

Transmitters are factory calibrated to customer's specified range. Calibrated range and tag number are stamped on the type plate. If calibration range and tag data are not specified, the transmitter will be supplied configured as follows:

4 mA	Zero
20 mA	Upper Range Limit (URL)
Output	Linear
Damping	0.125s
Transmitter failure mode	21mA

Any or all the above configurable parameters, including Lower range-value and Upper range-value which must be the same unit of measure, can be easily changed using the HART hand-held communicator or by a PC running the configuration software SMART VISION with DTM for 2600T. The transmitter database is customized with specified flange type and material, o-ring and filling liquid.

### Transmitter with PROFIBUS PA communication

Transmitters are factory calibrated to customer's specified range. Calibrated range and tag number are stamped on the type plate. If calibration range and tag data are not specified, the transmitter will be supplied configured as follows:

Measure Profile	Pressure
Engineering Unit	mbar/bar
Output scale 0%	Lower Range Limit (LRL)
Output scale 100%	Upper Range Limit (URL)
Output	Linear
Hi-Hi Limit	Upper Range Limit (URL)
Hi Limit	Upper Range Limit (URL)
Low Limit	Lower Range Limit (LRL)
Low-Low Limit	Lower Range Limit (LRL)
Limits hysteresis	0.5% of output scale
PV filter	0.125s.
Address	126

Any or all the above configurable parameters, including Lower range-value and Upper range-value which must be the same unit of measure, can be easily changed by a PC running the configuration software SMART VISION with DTM for 2600T.

The transmitter database is customized with specified flange type and material, o-ring and filling liquid.

### Transmitter with FOUNDATION Fieldbus communication

Transmitters are factory calibrated to customer's specified range. Calibrated range and tag number are stamped on the type plate. If calibration range and tag data are not specified, the transmitter will be supplied configured as follows:

Measure Profile	Pressure
Engineering Unit	mbar/bar
Output scale 0%	Lower Range Limit (LRL)
Output scale 100%	Upper Range Limit (URL)
Output	Linear
Hi-Hi Limit	Upper Range Limit (URL)
Hi Limit :	Upper Range Limit (URL)
Low Limit	Lower Range Limit (LRL)
Low-Low Limit	Lower Range Limit (LRL)
Limits hysteresis	0.5% of output scale
PV filter	0.125s
Address	Not necessary

Any or all the above configurable parameters, including lower range value and upper range value which must be the same unit of measure, can be changed by any FOUNDATION Fieldbus compatible configurator.

The transmitter database is customized with specified flange type and material, o-ring and filling liquid.

™ Hastelloy is a Cabot Corporation trademark

™ Viton is a Dupont de Nemour trademark

(\*) Wetted parts of the transmitter.

**MOUNTING DIMENSIONS** (not for construction unless certified) - dimensions in mm (in)

**Transmitter with barrel-type amplifier housing**

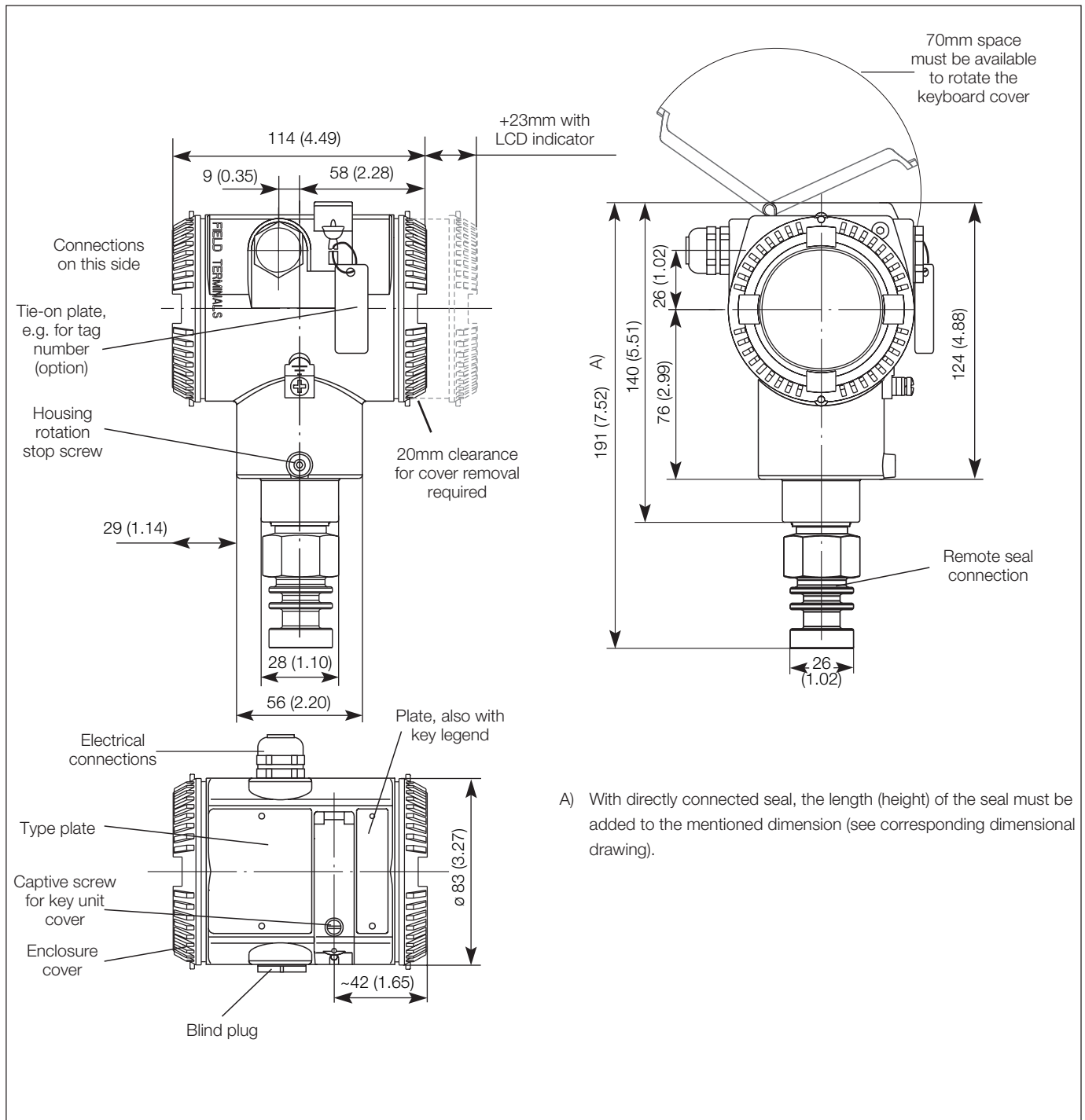

A) With directly connected seal, the length (height) of the seal must be added to the mentioned dimension (see corresponding dimensional drawing).

**MOUNTING DIMENSIONS** (not for construction unless certified) - dimensions in mm (in)

**Transmitter with DIN-type amplifier housing**

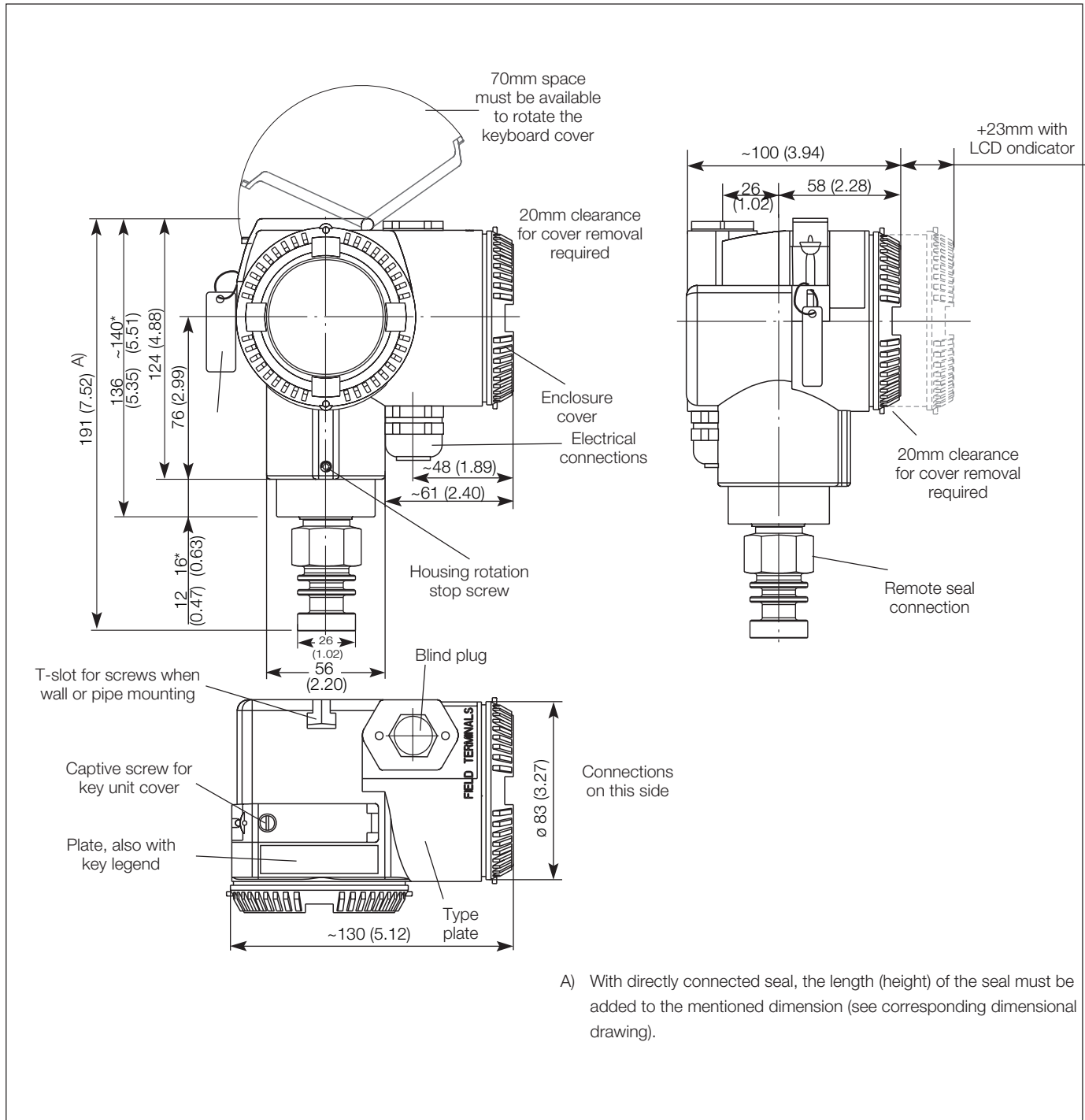

## Electrical connections

### Standard Terminal block and fieldbus connector versions

7/8" connector

M12 x 1 connector

PIN (male) IDENTIFICATION		
	FOUNDATION Fieldbus	PROFIBUS PA
1	FF-	PA+
2	FF+	GROUND
3	SHIELD	PA-
4	GROUND	SHIELD

Mating female plug NOT SUPPLIED

### Harting Han 8U connector

89 (3.5)

Harting pin identification  
(view onto socket)

26 (1.02)

**BASIC ORDERING INFORMATION model 265GR Gauge Pressure Transmitter with remote seal**

Select one character or set of characters from each category and specify complete catalog number.

Refer to additional ordering information code and specify one or more codes for each transmitter if additional options are required.

Quote separately one seal as required. FOR ORDER NUMBER OF REMOTE SEAL REFER TO DATA SHEET SS/S265.

<b>BASE MODEL</b> – 1 <sup>st</sup> to 5 <sup>th</sup> characters				<b>2</b>	<b>6</b>	<b>5</b>	<b>G</b>	<b>R</b>	<b>X</b>	<b>X</b>	<b>X</b>	<b>X</b>
Gauge Pressure Transmitter with remote seal – BASE ACCURACY 0.04%												
<b>SENSOR - Range / max Span</b> – 6 <sup>th</sup> character (Refer to table pag. 2 and 3)												
6kPa	60mbar	24inH <sub>2</sub> O							C			
40kPa	400mbar	160inH <sub>2</sub> O							F			
250kPa	2500mbar	1000inH <sub>2</sub> O							L			
3000kPa	30bar	435psi							U			
10000kPa	100bar	1450psi							R			
60000 kPa	600bar	8700psi							V			
<b>Diaphragm material / Fill fluid (wetted parts)</b> – 7 <sup>th</sup> character												
Hastelloy C276™	Silicone oil	with remote seal	(Note 1)						NACE	R		
Hastelloy C276™	Inert fluid	with remote seal	(Note 1)						NACE	2		
Ceramic	No filling	with remote seal	(Note 2)						NACE	3		
<b>Housing material and electrical connection</b> – 8 <sup>th</sup> character												
Aluminium alloy (Barrel version)		1/2in NPT										A
Aluminium alloy (Barrel version)		M20 x 1.5 (CM 20)	(Not available FM, CSA)									B
Aluminium alloy (Barrel version)		Harting Han 8U connector	(Note 3) (Not available ATEX EExd, FM, CSA)									E
Aluminium alloy (Barrel version)		Fieldbus connector	(Note 3) (Not available ATEX EExd, FM, CSA)									G
AISI 316 L ss (Barrel version)		1/2in NPT										S
AISI 316 L ss (Barrel version)		M20 x 1.5 (CM 20)	(Not available FM, CSA)									T
Aluminium alloy (DIN version)		M20 x 1.5 (CM 20)	(Not available FM, CSA)									J
Aluminium alloy (DIN version)		Harting Han 8U connector	(Note 3) (Not available ATEX EExd, FM, CSA)									K
Aluminium alloy (DIN version)		Fieldbus connector	(Note 3) (Not available ATEX EExd, FM, CSA)									W
<b>Output/Additional options</b> – 9 <sup>th</sup> character												
HART digital communication and 4 to 20mA		No additional options	(Note 4, 5)									H
HART digital communication and 4 to 20mA		Options requested (to be ordered by "Additional ordering code")	(Note 4)									1
PROFIBUS PA		No additional options	(Note 4, 5)									P
PROFIBUS PA		Options requested (to be ordered by "Additional ordering code")	(Note 5)									2
FOUNDATION Fieldbus		No additional options	(Note 4, 5)									F
FOUNDATION Fieldbus		Options requested (to be ordered by "Additional ordering code")	(Note 5)									3

**ADDITIONAL ORDERING INFORMATION for model 265GR**

Add one or more 2-digit code(s) after the basic ordering information to select all required options

	XX	XX	XX	XX	XX	XX	XX	XX	XX
<b>Electrical certification</b>									
ATEX Group II Category 1/2 GD – Intrinsic Safety EEx ia	E1								
ATEX Group II Category 1/2 G – Flameproof EEx d (Note 1)	E2								
ATEX Group II Category 3 GD – Type of protection "N" EEx nL energy limited	E3								
Factory Mutual (FM) – Intrinsically Safe	EA								
Factory Mutual (FM) – Explosion Proof (only with 1/2in NPT electrical connection and SS label) (Note 1)	EB								
Canadian Standard Association – Intrinsically Safe (pending)	ED								
Canadian Standard Association – Explosion Proof (Note 1)	EE								
<b>Integral LCD</b>									
Digital LCD integral display	L1								
Backlit digital LCD integral display	L2								
<b>Mounting bracket (shape and material)</b>									
For pipe mounting AISI 316 L ss	B2								
For wall mounting AISI 316 L ss	B4								
<b>Surge</b>									
Surge/Transient Protector (Note 6)	S1								
<b>Operating manual</b>									
German	M1								
<b>Labels &amp; tag language</b>									
German in stainless steel (not available with DIN Electronic Housing code J, K, W)	T1								
German and English plastic (not suitable for Factory Mutual - Explosion Proof)	TA								
<b>Additional tag plate</b>									
In stainless steel	I1								
<b>Certificates</b>									
Inspection certificate EN 10204–3.1.B of calibration	C1								
Inspection certificate EN 10204–3.1.B of the cleanliness stage according to DIN 25410	C3								
Inspection certificate EN 10204–3.1.B of helium leakage test of the sensor module	C4								
Inspection certificate EN 10204–3.1.B of the pressure test	C5								
Certificate of compliance with the order EN 10204–2.1 of instrument design	C6								
<b>Material traceability</b>									
Certificate of compliance with the order EN 10204–2.1 of process wetted parts	H1								
Inspection certificate EN 10204–3.1.B of process wetted parts (small parts with certificate of compliance EN 10204)	H3								
Test report EN 10204-2.2 of the pressure bearing and process wetted parts	H4								
<b>Connector</b>									
Fieldbus 7/8 (without mating female plug) (Notes 5, 7)	U1								
Fieldbus M12x1 (without mating female plug) (Notes 5, 7)	U2								
Harting Han 8U – straight entry (Notes 4, 7)	U3								
Harting Han 8U – angle entry (Notes 4, 8)	U4								

## 2600T Pressure Transmitters

Model 265GR, 265AR

SS/265GR/AR\_1

---

Note 1: Not available with Sensor code C, F

Note 2: Not available with Sensor code L, U, R, V

Note 3: Select type in additional ordering code

Note 4: Not available with Electronic Housing code G, W

Note 5: Not available with Electronic Housing code E, K

Note 6: Not available with ATEX-EEEx nL (code E3) or PROFIBUS PA / FOUNDATION Fieldbus (code 2 or 3) with Intrinsic Safety EEx i (code E1) or FM-Intrinsically Safe (code EA).

Note 7: Not available with Electronic housing code T, S, A, B, J

Note 8: Not available with Electronic housing code T, S, A, B, J, K

™ Hastelloy is a Cabot Corporation trademark

### **Standard delivery items (can be differently specified by additional ordering code)**

- General purpose (no Ex design)
- No meter/display, no mounting bracket, no surge protection
- English manual and labels (stainless steel nameplate for Barrel housing code A, B, E, G, S, T; plastic nameplate for DIN housing code J, K, W)
- Configuration with kPa and deg. C units
- No test, inspection or material traceability certificates

THE SELECTION OF SUITABLE WETTED PARTS AND FILLING FLUID FOR COMPATIBILITY WITH THE PROCESS MEDIA IS A CUSTOMER'S RESPONSIBILITY, IF NOT OTHERWISE NOTIFIED BEFORE MANUFACTURING.

**BASIC ORDERING INFORMATION model 265AR Absolute Pressure Transmitter with remote seal**

Select one character or set of characters from each category and specify complete catalog number.

Refer to additional ordering information code and specify one or more codes for each transmitter if additional options are required.

Quote separately one seal as required. FOR ORDER NUMBER OF REMOTE SEAL REFER TO DATA SHEET SS/S265.

BASE MODEL – 1 <sup>st</sup> to 5 <sup>th</sup> characters				2	6	5	A	R	X	X	X	X
Absolute Pressure Transmitter with remote seal – BASE ACCURACY 0.04%												
<b>SENSOR - Range / max Span – 6<sup>th</sup> character</b> (Refer to table pag. 2 and 3)												
40kPa	400mbar		160inH <sub>2</sub> O						F			
250kPa	2500mbar		1000inH <sub>2</sub> O						L			
3000kPa	30bar		435psi						U			
<b>Diaphragm material / Fill fluid (wetted parts) – 7<sup>th</sup> character</b>												
Hastelloy C276™	Silicone oil	with remote seal	(Note 1)						NACE	R		
Hastelloy C276™	Inert fluid	with remote seal	(Note 1)						NACE	2		
Ceramic	No filling	with remote seal	(Note 2)						NACE	3		
<b>Housing material and electrical connection – 8<sup>th</sup> character</b>												
Aluminium alloy (Barrel version)		1/2in NPT										A
Aluminium alloy (Barrel version)		M20 x 1.5 (CM 20)	(Not available FM, CSA)									B
Aluminium alloy (Barrel version)		Harting Han 8U connector	(Note 3) (Not available ATEX EExd, FM, CSA)									E
Aluminium alloy (Barrel version)		Fieldbus connector	(Note 3) (Not available ATEX EExd, FM, CSA)									G
AISI 316 L ss (Barrel version)		1/2in NPT										S
AISI 316 L ss (Barrel version)		M20 x 1.5 (CM 20)	(Not available FM, CSA)									T
Aluminium alloy (DIN version)		M20 x 1.5 (CM 20)	(Not available FM, CSA)									J
Aluminium alloy (DIN version)		Harting Han 8U connector	(Note 3) (Not available ATEX EExd, FM, CSA)									K
Aluminium alloy (DIN version)		Fieldbus connector	(Note 3) (Not available ATEX EExd, FM, CSA)									W
<b>Output/Additional options – 9<sup>th</sup> character</b>												
HART digital communication and 4 to 20mA		No additional options	(Note 4, 5)									H
HART digital communication and 4 to 20mA		Options requested (to be ordered by "Additional ordering code")	(Note 4)									1
PROFIBUS PA		No additional options	(Note 4, 5)									P
PROFIBUS PA		Options requested (to be ordered by "Additional ordering code")	(Note 5)									2
FOUNDATION Fieldbus		No additional options	(Note 4, 5)									F
FOUNDATION Fieldbus		Options requested (to be ordered by "Additional ordering code")	(Note 5)									3

**ADDITIONAL ORDERING INFORMATION for model 265AR**

Add one or more 2-digit code(s) after the basic ordering information to select all required options

	XX	XX	XX	XX	XX	XX	XX	XX	XX	XX
<b>Electrical certification</b>										
ATEX Group II Category 1/2 GD – Intrinsic Safety EEx ia	E1									
ATEX Group II Category 1/2 G – Flameproof EEx d (Note 1)	E2									
ATEX Group II Category 3 GD – Type of protection "N" EEx nL energy limited	E3									
Factory Mutual (FM) – Intrinsically Safe	EA									
Factory Mutual (FM) – Explosion Proof (only with 1/2in NPT electrical connection and SS label) (Note 1)	EB									
Canadian Standard Association – Intrinsically Safe (pending)	ED									
Canadian Standard Association – Explosion Proof (Note 1)	EE									
<b>Integral LCD</b>										
Digital LCD integral display	L1									
Backlit digital LCD integral display	L2									
<b>Mounting bracket (shape and material)</b>										
For pipe mounting     AISI 316 L ss									B2	
For wall mounting     AISI 316 L ss									B4	
<b>Surge</b>										
Surge/Transient Protector (Note 6)									S1	
<b>Operating manual</b>										
German									M1	
<b>Labels &amp; tag language</b>										
German in stainless steel (not available with DIN Electronic Housing code J, K, W)									T1	
German and English plastic (not suitable for Factory Mutual - Explosion Proof)									TA	
<b>Additional tag plate</b>										
In stainless steel									I1	
<b>Certificates</b>										
Inspection certificate EN 10204–3.1.B of calibration									C1	
Inspection certificate EN 10204–3.1.B of the cleanliness stage according to DIN 25410									C3	
Inspection certificate EN 10204–3.1.B of helium leakage test of the sensor module									C4	
Inspection certificate EN 10204–3.1.B of the pressure test									C5	
Certificate of compliance with the order EN 10204–2.1 of instrument design									C6	
<b>Material traceability</b>										
Certificate of compliance with the order EN 10204–2.1 of process wetted parts									H1	
Inspection certificate EN 10204–3.1.B of process wetted parts (small parts with certificate of compliance EN 10204)									H3	
Test report EN 10204-2.2 of the pressure bearing and process wetted parts									H4	
<b>Connector</b>										
Fieldbus 7/8 (without mating female plug) (Notes 5, 7)									U1	
Fieldbus M12x1 (without mating female plug) (Notes 5, 7)									U2	
Harting Han 8U – straight entry (Notes 4, 7)									U3	
Harting Han 8U – angle entry (Notes 4, 8)									U4	

## 2600T Pressure Transmitters

Model 265GR, 265AR

SS/265GR/AR\_1

---

- Note 1: Not available with Sensor code F
- Note 2: Not available with Sensor code L, U
- Note 3: Select type in additional ordering code
- Note 4: Not available with Electronic Housing code G, W
- Note 5: Not available with Electronic Housing code E, K
- Note 6: Not available with ATEX-Ex nL (code E3) or PROFIBUS PA / FOUNDATION Fieldbus (code 2 or 3) with Intrinsic Safety EEx i (code E1) or FM-Intrinsically Safe (code EA).
- Note 7: Not available with Electronic housing code T, S, A, B, J
- Note 8: Not available with Electronic housing code T, S, A, B, J, K

™ Hastelloy is a Cabot Corporation trademark

### **Standard delivery items (can be differently specified by additional ordering code)**

- General purpose (no Ex design)
- No meter/display, no mounting bracket, no surge protection
- English manual and labels (stainless steel nameplate for Barrel housing code A, B, E, G, S, T; plastic nameplate for DIN housing code J, K, W)
- Configuration with kPa and deg. C units
- No test, inspection or material traceability certificates

THE SELECTION OF SUITABLE WETTED PARTS AND FILLING FLUID FOR COMPATIBILITY WITH THE PROCESS MEDIA IS A CUSTOMER'S RESPONSIBILITY, IF NOT OTHERWISE NOTIFIED BEFORE MANUFACTURING.

## 2600T Pressure Transmitters

Model 265GR, 265AR

SS/265GR/AR\_1

---

ABB has Sales & Customer Support  
expertise in over 100 countries worldwide

[www.abb.com/instrumentation](http://www.abb.com/instrumentation)

The Company's policy is one of continuous product  
improvement and the right is reserved to modify the  
information contained herein without notice.

Printed in Italy (04.04)

© ABB 2004



**ABB Ltd**  
Howard Road, St. Neots  
Cambridgeshire, PE19 3EU  
UK  
Tel: +44(0)1480 475321  
Fax: +44(0)1480 217948

**ABB Inc.**  
125 E. County Line Road  
Warminster, PA 18974  
USA  
Tel: +1 215 674 6000  
Fax: +1 215 674 7183

**ABB Automation Products GmbH**  
Schillerstrasse 72  
D-32425 Minden  
Germany  
Tel: +49 (0) 551 905 534  
Fax: +49 (0) 551 905 555