

- **Base accuracy: $\pm 0.15\%$**
- **Span limits**
 - 0.3 to 60000 kPa; 1.2 inH₂O to 8700 psi
 - 0.3 to 3000 kPa abs; 2.25 mmHg to 435 psia
- **Reliable sensing system coupled with very latest digital technologies**
 - provides large turn down ratio up to 20:1
- **Stainless steel housing**
 - optimized for rough environment
 - extreme robust
- **Flexible configuration facilities**
 - local zero and span button
 - local configuration with keys on LCD indicator
 - remote configuration with hand terminal or PC based software
- **Full compliance with PED Category III**



**ABB 2600T Series
Engineered solutions
for all applications**



Functional Specifications

Range and span limits

Sensor Code	Upper Range Limit (URL)	Lower Range Limit (LRL) für 261GS	Minimum span	
			261GS gauge	261AS absolute
C	6 kPa 60 mbar 24 inH ₂ O	-6 kPa -60 mbar -24 inH ₂ O	0.3 kPa 3 mbar 1.2 inH ₂ O	0.3kPa 3 mbar 2.25 mmHg
F	40 kPa 400 mbar 160 inH ₂ O	-40 kPa -400 mbar -160 inH ₂ O	2 kPa 20 mbar 8 inH ₂ O	2 kPa 20 mbar 15 mmHg
L	250 kPa 2500 mbar 1000 inH ₂ O	0 absolute	12.5 kPa 125 mbar 50 inH ₂ O	12.5 kPa 125 mbar 93.8 mmHg
D	1000 kPa 10 bar 145 psi	0 absolute	50 kPa 500 mbar 7.25 psi	50 kPa 500 mbar 375 mmHg
U	3000 kPa 30 bar 435 psi	0 absolute	150 kPa 1.5 bar 21.7 psi	150 kPa 1.5 bar 21.7 psi
R	10000 kPa 100 bar 1450 psi	0 absolute	500 kPa 5 bar 72.5 psi	
V	60000 kPa 600 bar 8700 psi	0 absolute	3000 kPa 30 bar 435 psi	

Note:

Lower Range Limit (LRL) for 261AS is 0 absolute for all ranges.

Span limits

Maximum span = Upper range limit (URL)
IN ORDER TO OPTIMISE THE TRANSMITTER PERFORMANCE IT IS ADVISABLE TO SELECT THE TRANSMITTER SENSOR TO PROVIDE THE MINIMUM POSSIBLE TURNDOWN.
Turndown = Upper range limit / Calibrated span

Zero suppression and elevation

Zero and span can be adjusted to any value within the range limits detailed in the table as long as:
– calibrated span ≥ minimum span

Damping

Adjustable time constant: 0 to 60 s. This is in addition to sensor response time. Can be adjusted via local indicator, hand terminal or PC based software.

Turn on time

Operation within specification in less than 10 s with minimum damping.

Insulation resistance

> 100 MΩ at 500 V DC (terminals to earth)

Operative limits

Temperature limits °C (°F):

Ambient temperature limits (is the operating temperature)

white oil filling: -40°C and +85°C (-40°F and +185°F)
Lower limit for LCD indicator and Viton gasket: -6°C and +85°C (-21°F and +185°F)
-20°C (-4°F)
Lower limit for perfluorelastomer gasket: -25°C/-15°C (-13°F/+5°F) (ref. to section "Pressure Limits")
Upper limit for perfluorelastomer gasket: +80°C (+176°F)
Upper limit for LCD indicator: +70°C (+158°F)

Note:

For Hazardous Atmosphere applications see the temperature range specified on the certificate/approval relevant to the aimed type of protection.

Process temperature limits

Lower limit
– -50°C (-58°F); -20°C (-4°F) for Viton gasket
– -25°C/-15°C (-13°F/+5°F) for perfluorelastomer gasket (ref. to section "Pressure Limits")
– -6°C (+21°F) for white oil filling
Upper limit
– +120°C (+250°F)
– +80°C (+176°F) for perfluorelastomer gasket

Storage temperature limits

Lower limit: -50°C (-58°F), -40°C (-40°F) for LCD indicators
-6°C (+21°F) for white oil filling
Upper limit: +85°C (+185°F)

Pressure limits

Overpressure limits (without damage to the transmitter)

0 absolute to
– 1 MPa, 10 bar, 145 psi for sensor codes C, F
– 0.5 MPa, 5 bar, 72.5 psi for sensor code L
– 2 MPa, 20 bar, 290 psi für Sensorcode D
– 6 MPa, 60 bar, 870 psi for sensor code U
– 20 MPa, 200 bar, 2900 psi for sensor code R
– 90 MPa, 900 bar, 13050 psi for sensor code V
– 0.6 MPa abs, 6 bar abs, 87 psia for perfluorelastomer gasket, T ≥ -15 °C (+5 °F)
– 0.18 MPa abs, 1.8 bar abs, 26 psia for perfluorelastomer gasket, T ≥ -25 °C (-13 °F)

Proof pressure

The transmitter can be exposed to line pressure for pressure test up to:
refer to Overpressure limits

Environmental limits

Electromagnetic compatibility (EMC)

Complies with EMC directive 89 / 336 / EEC
as well as with EN 61000-6-3 for emission and
EN 61000-6-2 for immunity requirements and test
Fulfills NAMUR recommendation

Low voltage directive

Complies with 73 / 23 / EEC

Pressure equipment directive (PED)

Complies with 97 / 23 / EEC Category III module H.

Humidity

Relative humidity: up to 100 %
Condensing, icing: admissible

Vibration resistance

Accelerations up to 2 g at frequency up to 1000 Hz
(according to IEC 60068-2-6)

Shock resistance (according to IEC 60068-2-27)

Acceleration: 50 g
Duration: 11 ms

Wet and dust-laden atmospheres

The transmitter is dust and sand tight and protected against
immersion effects as defined by IEC EN 60529 (1989) to IP 67(IP 68,
IP 69K on request) or by NEMA to 4X or by JIS to C0920.

Hazardous atmospheres

Transmitters with hazardous area electrical certification

"Intrinsically safe EEx ia/ib"

comply with the directive 94 / 9 / EC (ATEX)

Transmitter with 4...20mA output signal and HART communication

Marking (DIN EN 50 014): II 1/2 G EEx ia IIC T4...T6
II 2 G EEx ib IIC T4...T6

Permissible ambient temperature depending on temperature class:
Ambient Temperature Temperature class
-40 °C...+85°C (-40 °F...+185 °F) T1 ... T4
-40 °C...+71°C (-40 °F...+159 °F) T5
-40 °C...+56°C (-40 °F...+132 °F) T6

or

Marking (DIN EN 50 014): II 1/2 D IP 65 T95 °C Ex ia D
II 2 D IP 65 T95 °C Ex ib D

Permissible ambient temperature:
-40 °C...+85°C (-40 °F...+185 °F)

Supply and signal circuit type of protection Intrinsic Safety

EEx ia/ib IIB/IIC with maximum values:

Ui = 30 V
Ii = 130 mA
Pi = 0.8 W

effective internal capacitance: Ci = 10 nF
effective internal inductance: Li = 10 µH

Factory Mutual (FM) (pending)

Transmitter with 4...20mA output signal and HART communication

Intrinsically safe: Class I, II and III; Division 1;
Groups A, B, C, D, E, F, G
Class I; Zone 0; AEx ia Group IIC T6; T4

Non-incentive Class I, II, and III, Division 2, Groups A, B, C, D, F, G

Degree of protection: NEMA Type 4X (indoor or outdoor)

Canadian Standard (CSA) (pending)

Transmitter with 4...20mA output signal and HART communication

Intrinsically safe: Class I, II and III; Division 1;
Groups A, B, C, D, E, F, G
Class I; Zone 0; AEx ia Group IIC T6; T4

Non-incentive Class I, II, and III, Division 2, Groups A, B, C, D, F, G

Degree of protection: NEMA Type 4X (indoor or outdoor)

Electrical Characteristics and Options

HART digital communication and 4...20mA output

Power Supply

The transmitter operates from 11...42 V DC with no load and is protected against reverse polarity connection (additional load allows operations over 42 V DC).
For EEx ia and other intrinsically safe approval power supply must not exceed 30 V DC.

Ripple

Maximum permissible voltage ripple of power supply during the communication:
According to HART FSK physical layer specification Rev. 8.1

Load limitations

4...20mA and HART total loop resistance:

$$R(k\Omega) = \frac{\text{Supply voltage} - \text{min. operating voltage (V DC)}}{22.5 \text{ mA}}$$

A minimum of 250 Ω is required for HART communication.

Integral display (optional)

Digital Graphic LCD display for user-specific indication of:
Gauge pressure / absolute pressure or
percentage of the output current or
output current in mA or
HART output (free choice of initial-, final value and unit)
Diagnostic messages, alarms, errors and measuring range infringements are also displayed.
Furthermore the LCD indicator can be used for configuration and parametrization of the transmitter via four keys.

Output signal

Two-wire, 4...20mA output
HART[®] communication provides digital process variable (% , mA or engineering units) superimposed on 4...20mA signal, with protocol based on Bell 202 FSK standard.

Output current limits (to NAMUR standard)

Overload condition
- Lower limit: 3.8 mA (configurable down to 3.5 mA)
- Upper limit: 20.5 mA (configurable up to 22.5 mA)

Alarm current

Min. alarm current: configurable from 3.5...4 mA,
standard setting: 3.6 mA
Max. alarm current: configurable from 20...22.5 mA,
standard setting: 21 mA
Standard setting: max. alarm current

SIL – Functional Safety (optional)

according to IEC 61508 / 61511

Device with Declaration of SIL Conformity for use in safety related applications up to SIL 2.

Performance specifications

Stated at reference condition to IEC 60770 ambient temperature of 20 °C (68 °F), relative humidity of 65 %, atmospheric pressure of 1013 hPa (1013 mbar), zero based range for transmitter with isolating diaphragms ceramic or Hastelloy and silicone oil fill.
Mode: linear, 4...20mA

Unless otherwise specified, errors are quoted as % of span.

The performances based to the Upper Range Limit (URL) are effected by the actual turndown (TD) as ratio between Upper Range Limit (URL) and calibrated span.

IT IS RECOMMENDED TO SELECT THE TRANSMITTER SENSOR CODE PROVIDING THE TURNDOWN VALUE AS LOWEST AS POSSIBLE TO OPTIMIZE PERFORMANCE CHARACTERISTICS.

Dynamic performance (according to IEC 61298–1 definition)

Dead time: 100 ms
Time constant (63.2 % of total step change):
– 150 ms for all sensors

Accuracy rating

% of calibrated span, including combined effects of terminal based linearity, hysteresis and repeatability.

– ± 0.15 % for TD from 1:1 to 10:1

– $\pm \left(0.15 \% + 0.005 \times \frac{\text{URL}}{\text{Span}} - 0.05 \% \right)$ for TD greater than > 10:1

Operating influences

Ambient temperature

per 10 K (18 °F) change between the limits of
-10 °C to +60 °C (+14 °F to +140 °F):
 $\pm(0.15$ % URL + 0.15 % span)

Supply voltage

Within voltage/load specified limits the total effect is less than 0.001 % of URL per volt.

Load

Within load/voltage specified limits the total effect is negligible.

Radio frequency interference

Total effect: less than 0.3 % of span from 80 to 1000 MHz and for field strengths up to 10 V/m when tested with unshielded conduit, with or without meter.

Stability

± 0.10 % of URL over a 12 month period

Vibration effect

± 0.10 % of URL (according to IEC 61298-3)

Physical Specification

(Refer to ordering information sheets for variant availability related to specific model)

Materials

Process isolating diaphragms ¹⁾

Ceramic (Al₂O₃) gold-plated; Hastelloy C276™;
Hastelloy C276™ gold-plated; AISI 316 L ss

Process connection ¹⁾

AISI 316 L ss; Hastelloy C276™

Gasket (only for sensor codes C, F)

Viton™, Perfluorelastomer, Perbunan (NBR)

Sensor fill fluid

Silicone oil; inert fill (Carbon fluoride); white oil (FDA)

Mounting bracket

AISI 316 L ss.

Sensor housing

AISI 316 L ss.

Electronic housing and covers

AISI 316 C ss.

Filter for atmosphere ventilation

plastic (standard), stainless steel

Cover O-ring

EPDM

Tagging

Plastic data plate attached to the electronic housing

Calibration

Standard: 0 to Upper Range Limit (URL)
Optional: at specified range

Optional extras

Mounting brackets

For vertical and horizontal 60 mm (2 in) pipes or wall mounting.

Integral display

graphic display, plug-in rotatable LCD indicator

Supplemental customer tag

AISI 316 ss tag fastened to the transmitter with stainless steel wire for customer's tag data up to a maximum of 30 characters and spaces.

Cleaning procedure for oxygen service

Test Certificates (test, design, calibration, material traceability)

Manual language

Process connections

1/2–14 NPT female or male; DIN EN837–1 G 1/2 B or G 1/2 B (HP)
for convex seal; front bonded diaphragm; for ball valve.

Electrical connections

one M16 x 1.5 threaded conduit entry, direct on housing
or 1/2-14 NPT (without cable gland)
or M20 x 1.5 (without cable gland)
or Harting Han connector
or Miniature-connector (without plug socket)

Terminal block

HART version: two terminals for signal/supply voltage wiring up to
1.5 mm² (16 AWG).

Grounding (Option)

External 4 mm² (12 AWG) ground termination point.

Mounting position

Transmitter can be mounted in any position.

Mass (without options)

0.7 kg approx (1.54 lb).
Add 650 g (1.43 lb) for packing.

Packing

Carton 24 x 14 x 19 cm approx (10 x 6 x 8 in).

Configuration

Transmitter with HART communication and 4...20 mA

Standard configuration

Transmitters are factory adjusted to customer's specific range. Adjusted range and tag number are marked on the type plate. If calibration range and tag data are not specified, the transmitter will be supplied configured as follows:

4 mA	Zero
20 mA	Upper Range Limit (URL)
Output	Linear
Damping	0,1 s
Transmitter failure mode	21 mA
LCD indicator (optional)	0...100 %

Any or all the above configurable parameters, including Lower range-value and Upper range-value, can be easily changed with the optional LCD indicator, using a HART hand-held communicator or by a PC, running the configuration software SMART VISION with DTM for 2600T.

™ Hastelloy is a Cabot Corporation trademark

™ Viton is a Dupont de Nemour trademark

¹⁾ Wetted parts of the transmitter

Mounting dimensions (not for construction unless certified) – dimensions in mm (in)

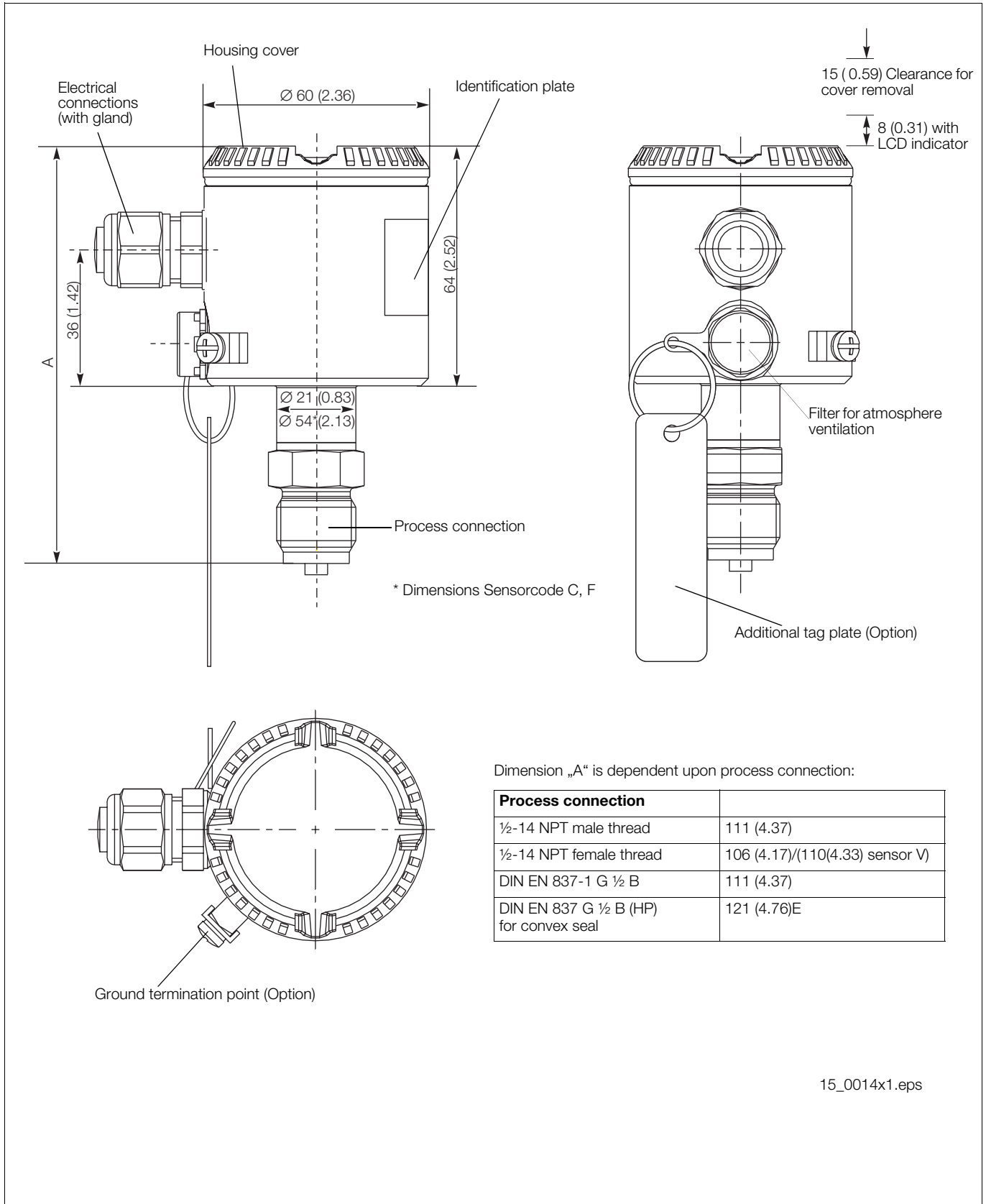

Dimension „A“ is dependent upon process connection:

Process connection	
1/2-14 NPT male thread	111 (4.37)
1/2-14 NPT female thread	106 (4.17)/(110(4.33) sensor V)
DIN EN 837-1 G 1/2 B	111 (4.37)
DIN EN 837 G 1/2 B (HP) for convex seal	121 (4.76)E

15_0014x1.eps

Design with the options LCD indicator and Harting Han connector

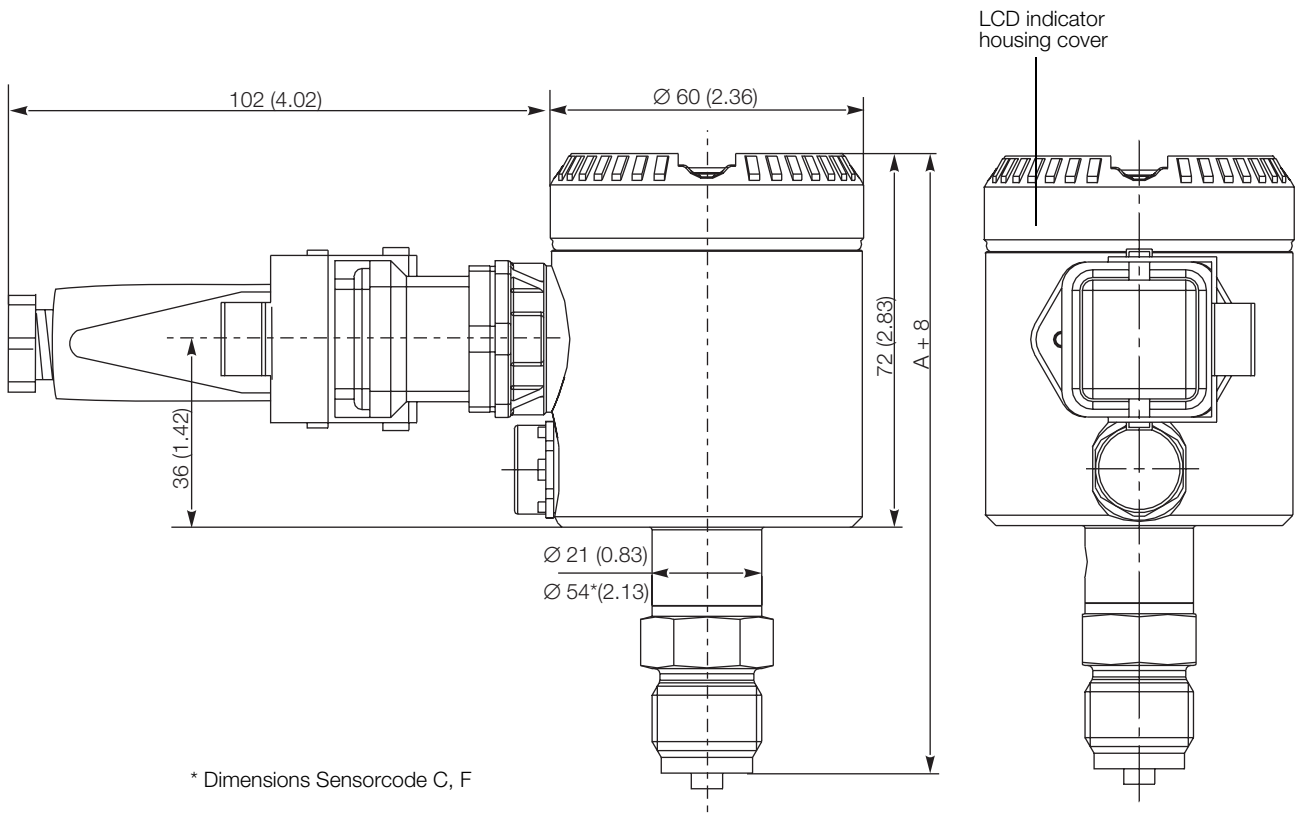

Dimension „A“ is dependent upon process connection:

Process connection	
1/2-14 NPT male thread	111 (4.37)
1/2-14 NPT female thread	106 (4.17)/(110(4.33) sensor V)
DIN EN 837-1 G 1/2 B	111 (4.37)
DIN EN 837 G 1/2 B (HP) for convex seal	121 (4.76)E

15_0015x1.eps

Possible mounting with bracket (optional)

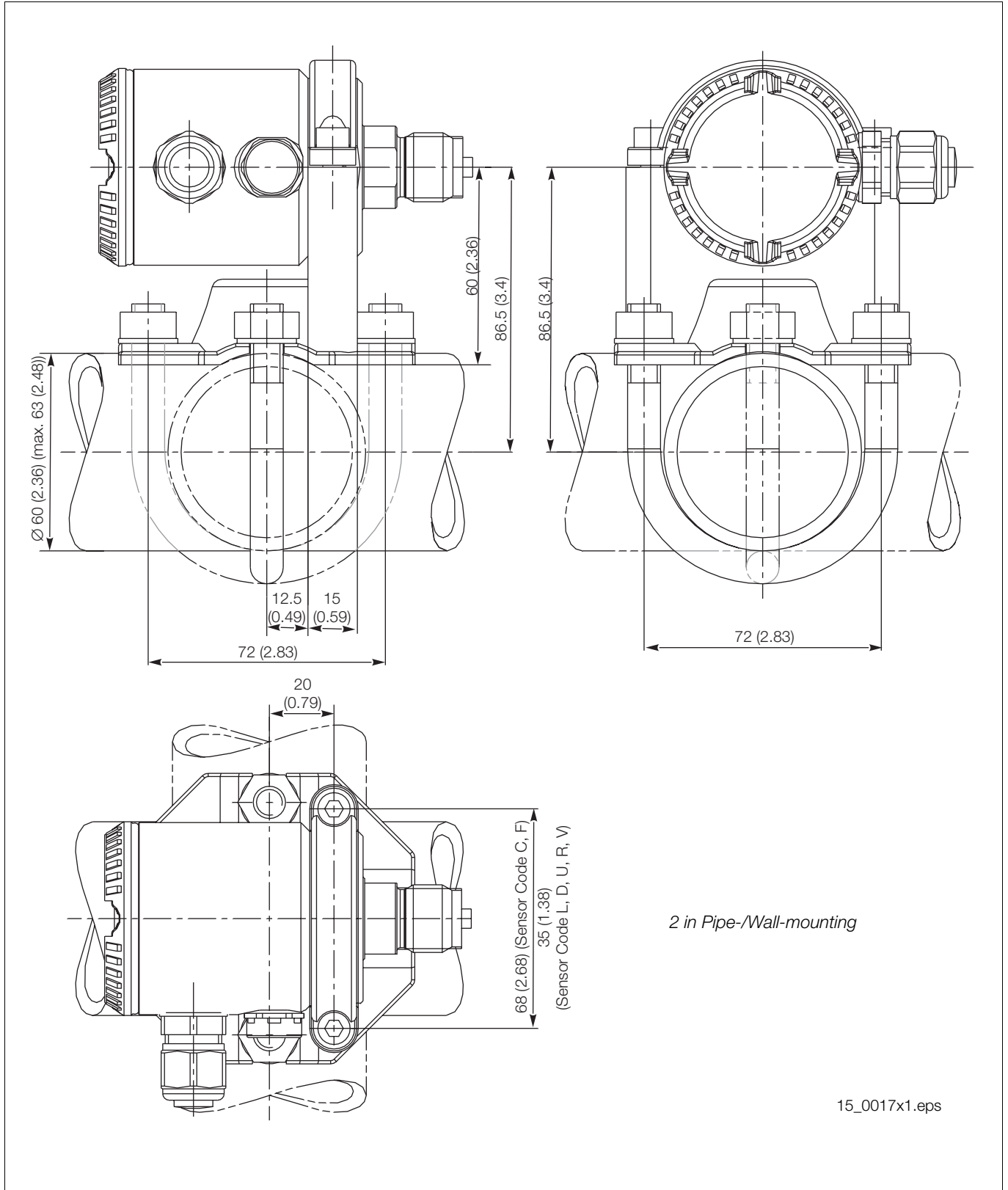

Note: Bracket both for pipe and wall mounting provides four holes of 10.5 mm (0.41 in) diameter on square with 72 mm (2.84 in) side

Electrical connections

Standard Terminal block

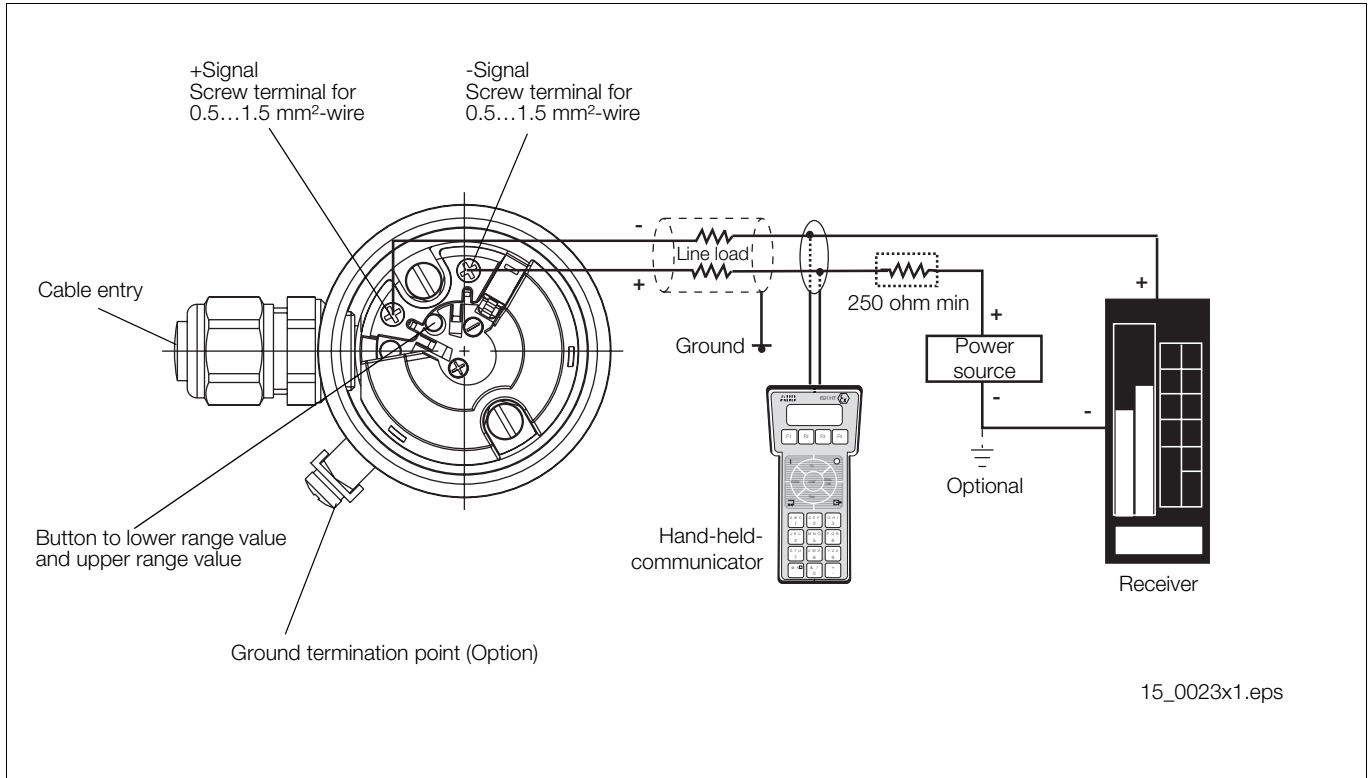

Connector Versions

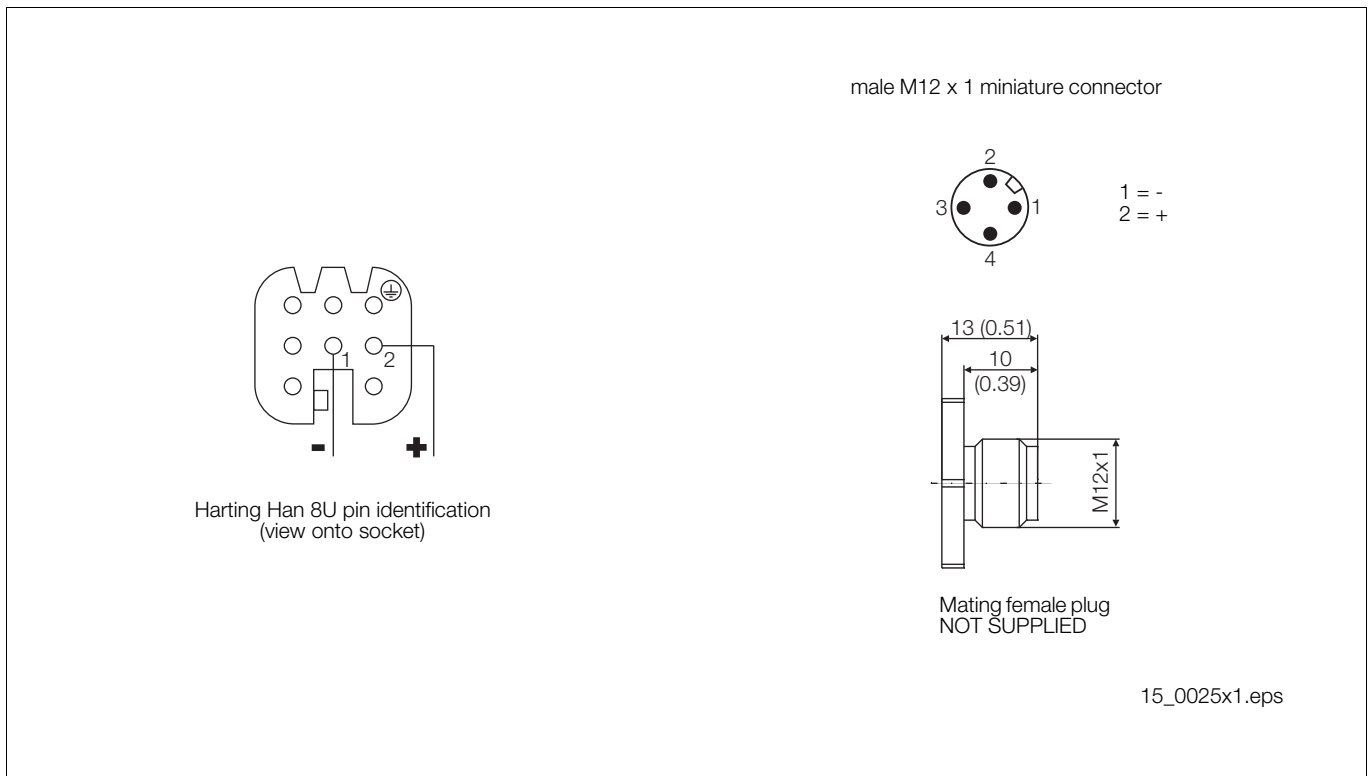

Ordering information

Variant digit No.				1-5	6	7	8	9	10	11	Code		
Gauge Pressure Transmitter 261GS				Catalog No.		261GS							
Base accuracy 0.15 %													
Sensor-Span limits				Overpressure limit									
0.3...6 kPa	3...60 mbar	1.2...24 in H ₂ O	1 MPa, 145 psi	C									
2...40 kPa	20...400 mbar	8...160 in H ₂ O	1 MPa, 145 psi	F									
12.5...250 kPa	125...2500 mbar	50...1000 in H ₂ O	0.5 MPa, 72.5 psi	L									
50...1000 kPa	0.5...10 bar	7.25...145 psi	2 MPa, 290 psi	D									
150...3000 kPa	1.5...30 bar	21.7...435 psi	6 MPa, 870 psi	U									
500...10000 kPa	5...100 bar	72.5...1450 psi	20 MPa, 2900 psi	R									
3000...60000 kPa	30...600 bar	435...8700 psi	90 MPa, 13050 psi	V									
Absolute Pressure Transmitter 261AS				Catalog No.		261AS							
Base accuracy 0.15 %													
Sensor-Span limits				Overpressure limit									
0.3...6 kPa	3...60 mbar	2.25...45 mmHg	1 MPa, 145 psi	C									
2...40 kPa	20...400 mbar	15...300 mmHg	1 MPa, 145 psi	F									
12.5...250 kPa	125...2500 mbar	93.8...1875 mmHg	0.5 MPa, 72.5 psi	L									
50...1000 kPa	0.5...10 bar	375...7500 mmHg	2 MPa, 290 psi	D									
150...3000 kPa	1.5...30 bar	21.7...435 psi	6 MPa, 870 psi	U									
Diaphragm material (wetted parts) / Fill fluid													
Hastelloy C276™	Siliconoil	NACE	2)	K									
Hastelloy C276™ gold-plated	Siliconoil	NACE	2)	G									
AISI 316 L ss	Siliconoil	NACE	2)	S									
	only for front bonded diaphragm												
Hastelloy C276™	Inert fluid	NACE	1, 2)	F									
Hastelloy C276™ gold-plated	Inert fluid	NACE	1, 2)	E									
AISI 316 L ss	Inert fluid	NACE	2)	A									
	only for front bonded diaphragm												
Hastelloy C276™	White oil (FDA)	NACE	2)	Z									
AISI 316 L ss	White oil (FDA)	NACE	2)	N									
	only for front bonded diaphragm												
Ceramic	No filling	NACE	3)	J									
Process connection material / Process connection (wetted parts)													
AISI 316 L ss	1/2-14 NPT female	NACE		B									
AISI 316 L ss	DIN EN 837-1 G 1/2 B	NACE		P									
AISI 316 L ss	G 1/2 front bonded diaphragm	NACE	2)	S									
AISI 316 L ss	1/2-14 NPT male	NACE		T									
AISI 316 L ss	DIN EN 837-1 G 1/2 B (HP) for convex seal	NACE	2)	U									
AISI 316 L ss	For ball valve connection	NACE	2)	V									
Gasket													
Viton™		NACE	1, 3)	5									
Perfluorelastomer (P _{max} = 0.6 MPa)		NACE	3)	6									
Buna			3)	8									
None		NACE	2)	N									
Electronic housing													
Housing material		Electrical connection											
AISI 316 L ss		M16 x 1,5 (with cable gland made of plastic)							2				
AISI 316 L ss		1/2-14 NPT (without cable gland)							S				
AISI 316 L ss		M20 x 1.5 (without cable gland)							T				
AISI 316 L ss		Harting Han connector					4)		3				
AISI 316 L ss		Miniature-connector					4)		Z				
Output / Additional options													
HART digital communication and 4...20 mA		No additional options						5)	H				
HART digital communication and 4...20 mA		Options requested (to be ordered by "Additional ordering code")							1				

- 1) Suitable for oxygen service (O₂)
- 2) Not available with sensor range 60 and 400 mbar
- 3) Only available with sensor range 60 and 400 mbar
- 4) Select type in additional ordering code
- 5) Not available for electrical connection with connector

Additional ordering information

	Code		
Electrical certification ATEX Group II Category 1/2 G – Intrinsic Safety EEx ia ATEX Group II Category 1/2 D – Intrinsic Safety EEx ia (without cable gland) Factory Mutual (FM) – Intrinsically Safe Canadian Standard Association (CSA) – Intrinsically Safe	EH EL EA ED		
Integral LCD Digital LCD integral display	L1		
Electrical housing accessories Housing with external earthing/potential equalizing terminal M16 x 1.5 cable gland and atmosphere ventilation made of metal	AA AB		
Mounting bracket (shape and material) For pipe mounting AISI 316 L ss For wall mounting AISI 316 L ss	B2 B4		
Preparation procedure Oxygen service cleaning (O ₂) (Only available with inert fill and for sensor code C, F - Viton gasket) P _{max} = 21 MPa/210 bar/3045 psi, T _{max} = 60 °C/140 °F	P1		
Operating manual German	M1		
Additional tag plate Stainless steel, laser printed	I1		
Certificates/approvals Inspection certificate EN 10204-3.1.B of calibration Inspection certificate EN 10204-3.1.B of the cleanliness stage according to DIN 25410 Inspection certificate EN 10204-3.1.B of helium leakage test of the sensor module Inspection certificate EN 10204-3.1.B of the pressure test Certificate of compliance with the order EN 10204-2.1 of instrument design SIL2 - declaration of conformity	C1 C3 C4 C5 C6 CL		
Material traceability Certificate of compliance with the order EN 10204-2.1 of process wetted parts Inspection certificate EN 10204-3.1.B of the pressure-bearing and process wetted parts with analysis certificates as material verification (minor parts with Factory Certificate acc. to "EN 10 204") Test report EN 10204-2.2 of the pressure bearing and process wetted parts	H1 H3 H4		
Connector Miniature plug M12x1 (without plug socket) Harting Han 8U – straight entry	U2 U3		

6) Only available for electrical connection with Harting Han connector and output HART

Standard delivery items (can be differently specified by additional ordering code)

- General purpose (no electrical certification)
- No meter/display, no mounting bracket
- English manual and english-german labels
- Configuration with kPa and deg. C units
- No test, inspection or material traceability certificates

THE SELECTION OF SUITABLE WETTED PARTS AND FILLING FLUID FOR COMPATIBILITY WITH THE PROCESS MEDIA IS A CUSTOMER'S RESPONSIBILITY, IF NOT OTHERWISE NOTIFIED BEFORE MANUFACTURING.

ABB has Sales & Customer Support expertise in over 100 countries worldwide.

www.abb.com

The Company's policy is one of continuous product improvement and the right is reserved to modify the information contained herein without notice.

Printed in the Fed. Rep. of Germany (09.05)

© ABB 2005



ABB Ltd.

Howard Road, St. Neots
Cambridgeshire, PE19 8EU
UK

Tel: +44 (0)1480 475321
Fax: +44 (0)1480 217948

ABB Inc.

125 E. County Line Road
Warminster, PA 18974
USA

Tel: +1 215 674 6000
Fax: +1 215 674 7183

ABB Automation Products GmbH

Schillerstr. 72
32425 Minden
Germany

Tel: +49 551 905-534
Fax: +49 551 905-555
CCC-support@de.abb.com