

## Resistance thermometer TSBA (SensyTemp BA R)

for building automation, machine construction  
and environmental engineering

### ■ Different output signals

- Pt 100 signal
- 4...20 mA, temperature linear, analog
- 4...20 mA, HART protocol (on request)

### ■ Short response time

### ■ Models for intrinsic safe circuits available

### ■ High operational reliability

- Long term stability
- Maintenance free



## General description

The product range presented in this catalog is a special selection adapted to the specific requirements of building automation, machine construction and environmental engineering. It is a result of both our close co-operation with our customers and our experience gained over years in the field of temperature measurement and process control instrumentation.

The transmitter is installed directly in the connection head, yielding the following benefits:

- simplified installation and commissioning procedure
- cost reduction due to minimized cabling expenditure
- interference immunity for 4...20 mA signal transmission, even over long distances
- error signalling in the event of sensor break, sensor short
- circuit and polarity reversal
- long-time stability, since no potentiometers are used
- high immunity to environmental influences and vibration due to full encapsulation

Our quality assurance system in accordance with DIN EN ISO 9001 guarantees that our products comply with the highest quality standards. Our environmental management system to DIN EN ISO 14001 introduced and certified in 1997 ensures that the production in our factory is both resource-saving and environmentally friendly.

These temperature sensors for building automation, machine construction and environmental engineering use platinum resistance sensor elements. Most sensor types are available with or without an integrated transmitter. The transmitter is connected to a supply unit through a 2-wire cable and provides a 4...20 mA output signal. The measuring range is set permanently in factory. A programmable or HART-compatible transmitter is also available.

## Type overview

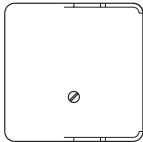
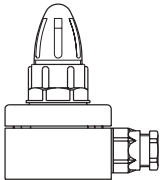
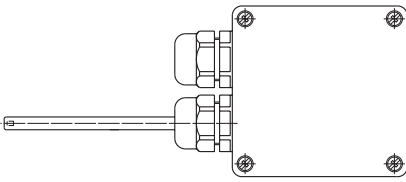
Model	Type	Possible applications
	Ambient temperature sensor TSBA (BA R-700)  Previous designation: BA R-R/WTR	Offices Meeting rooms Homes
	Ambient temperature sensor TSBA (BA R-750)  Previous designation: BA R-RF/WTRF	Cold stores Store rooms Production rooms Cellars
	Ambient indoor and outdoor temperature sensor TSBA (BA R-500) TSBA (BA R-500-i) (EEx i Zone 1)	Cold stores Outdoor temperature measurement Store rooms Production rooms Cellars

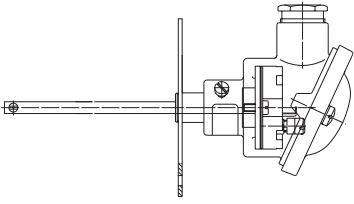
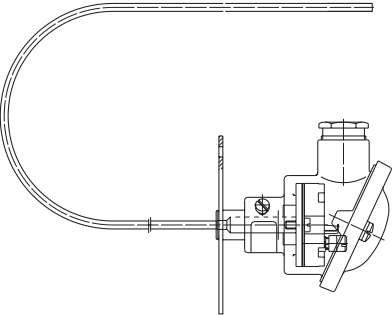
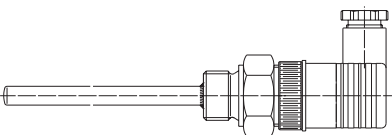
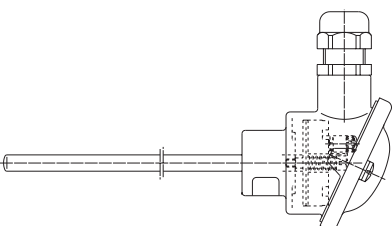
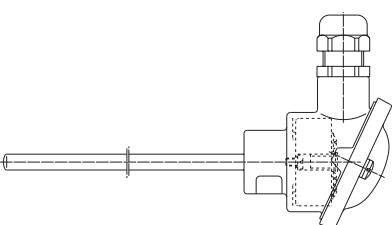
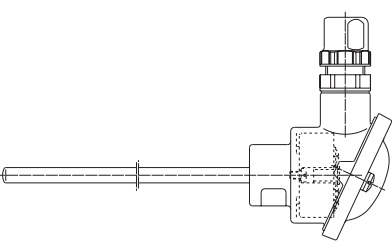
Model	Type	Possible applications
	<p>Air duct temperature sensor TSBA (BA R-300)</p> <p>Previous designation: BA R-L/WTL</p>	<p>Air ducts</p>
	<p>Average temperature sensor TSBA (BA R-900)</p> <p>Previous designation: BA R-Lm/WTLm</p>	<p>Air registers Air ducts Air shafts Environmental protection</p>
	<p>Pipeline temperature sensor TSBA (BA R-150)</p> <p>Previous design.: BA R-Ro/1 / WTRo/1</p>	<p>Water pipes Heating pipes Sewage pipes Mechanical engineering</p>
	<p>Pipeline and air duct temperature sensor with exchangeable measuring inset TSBA (BA R-200)</p> <p>Previous design.: BA R-Ro/2 / WTRo/2</p>	<p>Air ducts, water pipes, heating pipes, sewage pipes, mechanical engineering, environmental engineering</p>
	<p>Pipeline and air duct temperature sensor TSBA (BA R-250)</p>	<p>Air ducts, water pipes, heating pipes, sewage pipes, mechanical engineering, environmental engineering</p>
	<p>Pipeline and air duct temperature sensor with quick-release connector SensyTemp Quick</p>	<p>Air ducts, water pipes, heating pipes, sewage pipes, mechanical engineering, environmental engineering</p>

## Ambient temperature sensor TSBA (BA R-700)

Resistance thermometer for measuring the air temperature in dry indoor rooms

**Typical applications:**  
Homes, offices, function room

### Technical data

**Sensor**

1 x Pt 100

**Standard, tolerance**

EN 60751 (IEC 60751), Class B

**Circuit type**

4-wire

**Measuring range**

-20...+80 °C

### Housing

**Material**

Plastic

**Color**

Upper part: cream (RAL 9013) with air ducts  
Bottom part: black, ready for wall or flush mounting

**Dimensions**

70 mm x 70 mm x 30 mm

**Degree of protection**

IP 20

### Dimensions, wiring diagrams

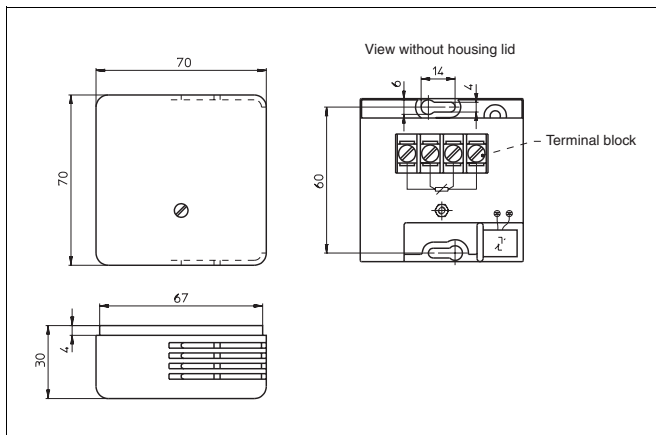

See page 12 for ordering details.

## Ambient temperature sensor TSBA (BA R-750)

Quick-response resistance thermometer for measuring the air temperature in dry and humid indoor rooms

**Typical applications:** cold stores, store rooms, production rooms, cellars, air shafts

### Technical data

**Sensor**

1 x Pt 100 or 2 x Pt 100

**Standard, tolerance**

EN 60751 (IEC 60751), class B

**Circuit type**

2-wire

**Measuring range**

-30...+70 °C

### Housing

**Material**

Polycarbonate

**Color**

Light grey (RAL 7035)

**Dimensions**

50 mm x 52 mm x 80 mm

**Degree of protection**

IP 65

**Cable entry**

PG 9

### Dimensions

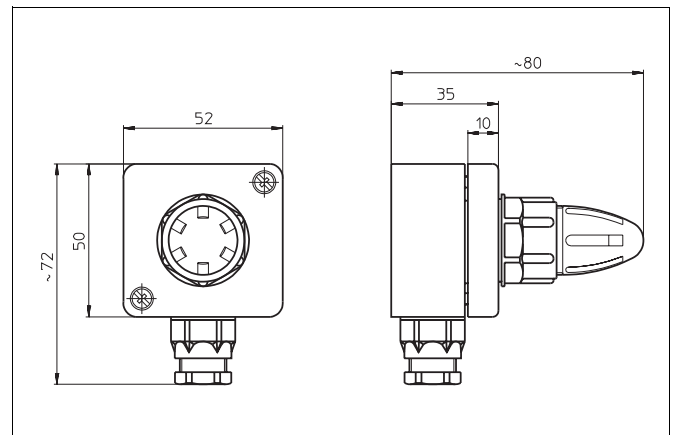

See page 12 for ordering details.

## Ambient indoor and outdoor temperature sensor TSBA (BA R-500)

### Resistance thermometer for measuring the air temperature in dry and humid indoor rooms and outside

Type TSBA (BA R-500) is also available as type TSBA (BA R-500-i). This model is intrinsically safe EEx i in accordance with DIN EN 50 014, 50 020-5.4 and DIN EN 60 079-1 with manufacturer's declaration for use in Zone 1 and Zone 2.

**Typical applications: outdoor temperature measurement, cold rooms, store rooms, production rooms, cellars**

### Technical data

#### Sensor

1 x Pt 100

#### Standard, tolerance

EN 60751 (IEC 60751), Class B

#### Circuit type

3-wire

#### Measuring range without integrated transmitter

-40...+80 °C

#### Transmitter

Type TR04 for TSBA (BA R-500)  
Type TR04-Ex for TSBA (BA R-500-i)

#### Measuring range of the integrated transmitter

-30...+60 °C

#### Housing

#### Material

Plastic, ABS

#### Color

Light grey

#### Dimensions

80 mm x 82 mm x 55 mm

#### Degree of protection

IP 66

#### Cable entry

M20 x 1.5

### Dimensions, wiring diagrams

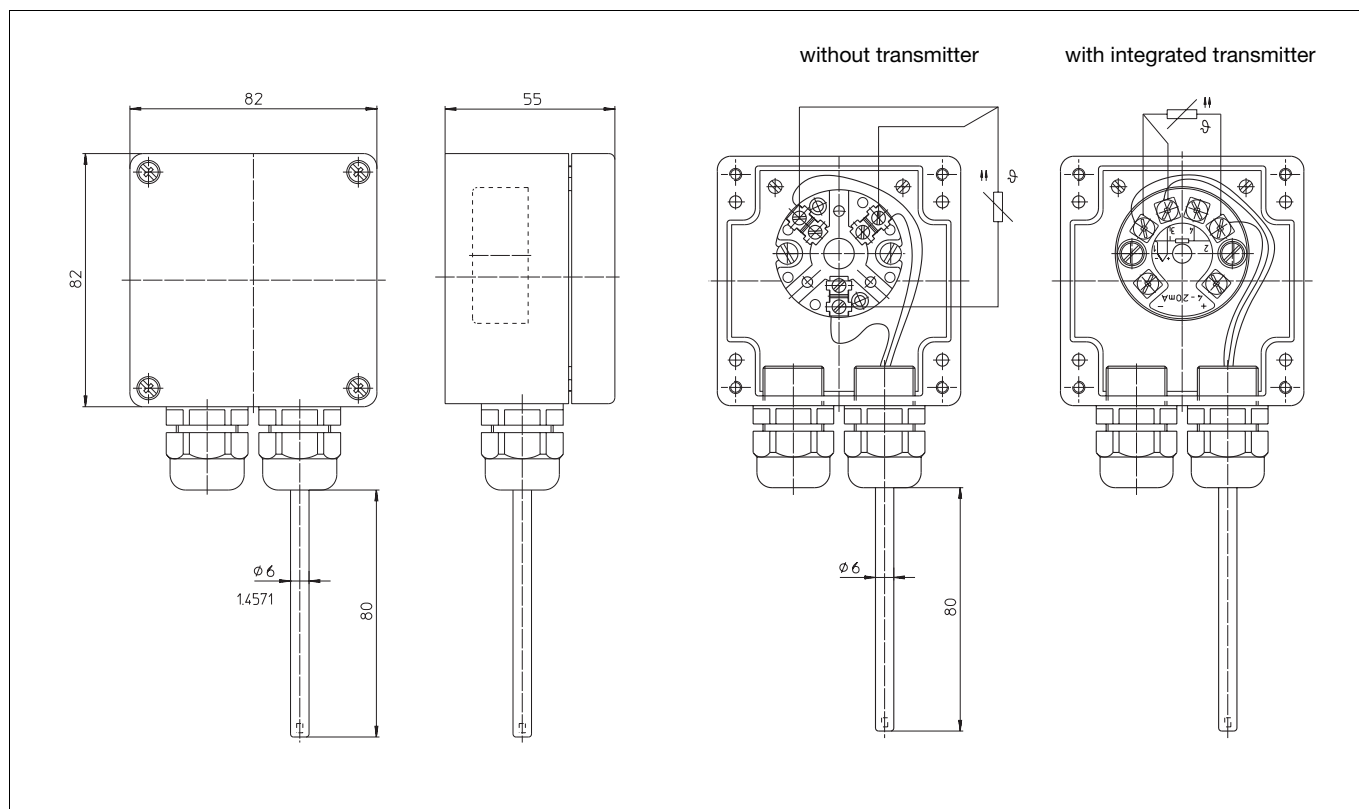

See page 12 for ordering details.

## Air duct temperature sensor TSBA (BA R-300)

### Resistance thermometer for temperature measurement in air ducts

Typical applications: air ducts, air shafts

### Technical data

#### Sensor

1 x Pt 100

#### Standard, tolerance

EN 60751 (IEC 60751), Class B

#### Circuit type

2-wire

#### Measuring range without integrated transmitter

-50...+130 °C

#### Transmitter

Type TR04

#### Measuring range of the integrated transmitter

-30...+60 °C

#### Mounting

Sheet metal flange, chromated, diameter 90 mm

#### Insertion length

200 mm or 330 mm

#### Measuring inset

- exchangeable
- diameter 6 mm, base not closed, tip with 2 drilled holes
- stainless steel sheath
- inset length = insertion length + 38 mm

#### Connection head

Without transmitter: Type B  
With transmitter: Type BH

#### Cable entry

M20 x 1.5

#### Degree of protection

IP 53

#### Response times (medium air, $v = 1$ m/s)

$t_{0,5} = 6$  s

$t_{0,9} = 20$  s

#### Insertion position

Drilled hole in direction of flow

### Dimensions, wiring diagrams

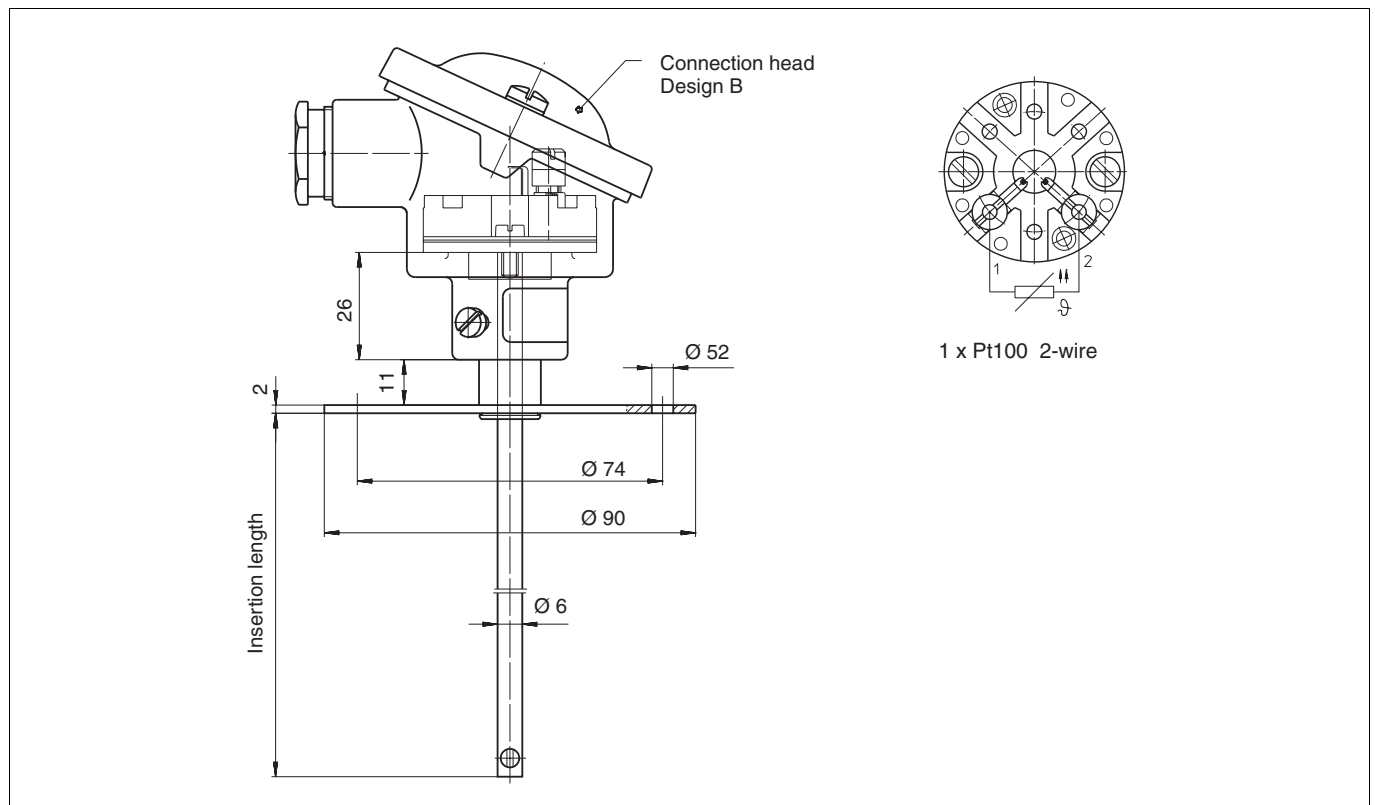

See page 12 for ordering details.

## Average temperature sensor TSBA (BA R-900)

The average temperature sensor has a measuring winding over its entire length for measuring the average temperature in large rooms or ducts.

### Typical applications:

**Air registers, air ducts, air shafts, environmental protection equipment**

### Technical data

#### Measuring winding

1 x Pt 100

#### Standard, tolerance

EN 60751 (IEC 60751), Class B

#### Circuit type

2-wire

#### Measuring range without integrated transmitter

-40...+150 °C

#### Transmitter

Type TR04

#### Measuring range of integrated transmitter

-20...+40 °C or  
-30...+60 °C

#### Thermowell

Diameter: 4 mm  
Material: copper

#### Mounting

Chromated sheet metal flange, diameter 90 mm  
Accessories: 5 mounting clamps, included in scope of delivery

#### Active length

6000 mm or 10000 mm

#### Connection head

Without transmitter: Type B  
With transmitter: Type BH

#### Cable entry

M20 x 1.5

#### Degree of protection

IP 53

## Dimensions, wiring diagrams

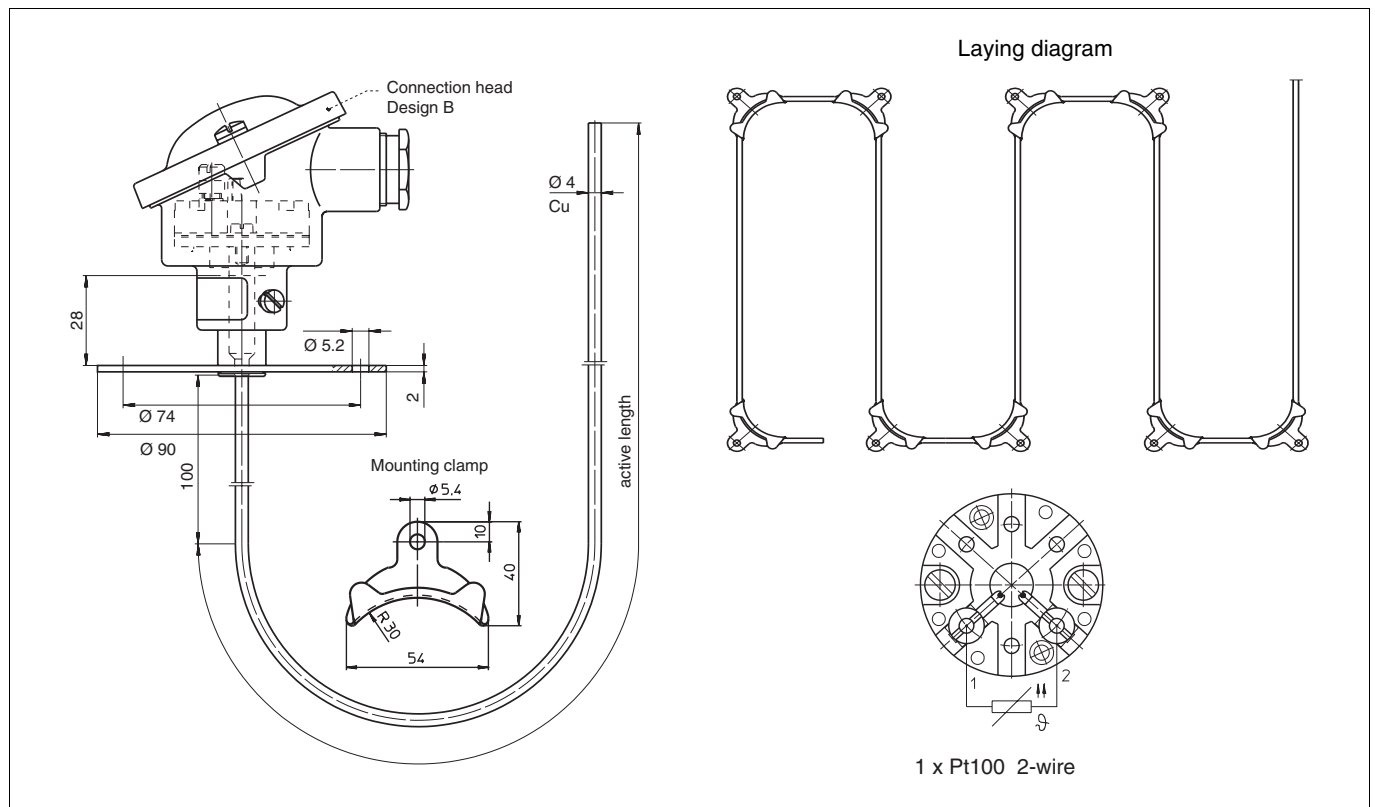

See page 12 for ordering details.

## Pipeline temperature sensor TSBA (BA R-150)

### Resistance thermometer for temperature measurement in pipelines

Due to its excellent response time and its immunity to shock and vibration, the TSBA (BA R-150) model is best suited for temperature measurement in mechanical engineering.

Standardized connectors to DIN 43650 are used for making the electrical connection. The contact pins of the connector plugs are gold-plated to avoid transition resistance resulting from corrosion. Due to this special feature the TSBA (BA R-150) model is also suitable for use in harsh industrial environments.

The device connector socket complies with flame class V0 to UL94. A profile packing is used to seal the transition between the fixed and the removable connector part. Contrary to the most commonly used flat packing the profile packing remains on the device socket even when the device is disconnected and, thus, cannot be lost.

#### Typical applications:

**Water pipes, heating pipes, sewage pipes, temperature measurement of cooling water, oil, and engine intake air.**

### Technical data

#### Measuring winding

1 x Pt 100

### Dimensions, wiring diagrams

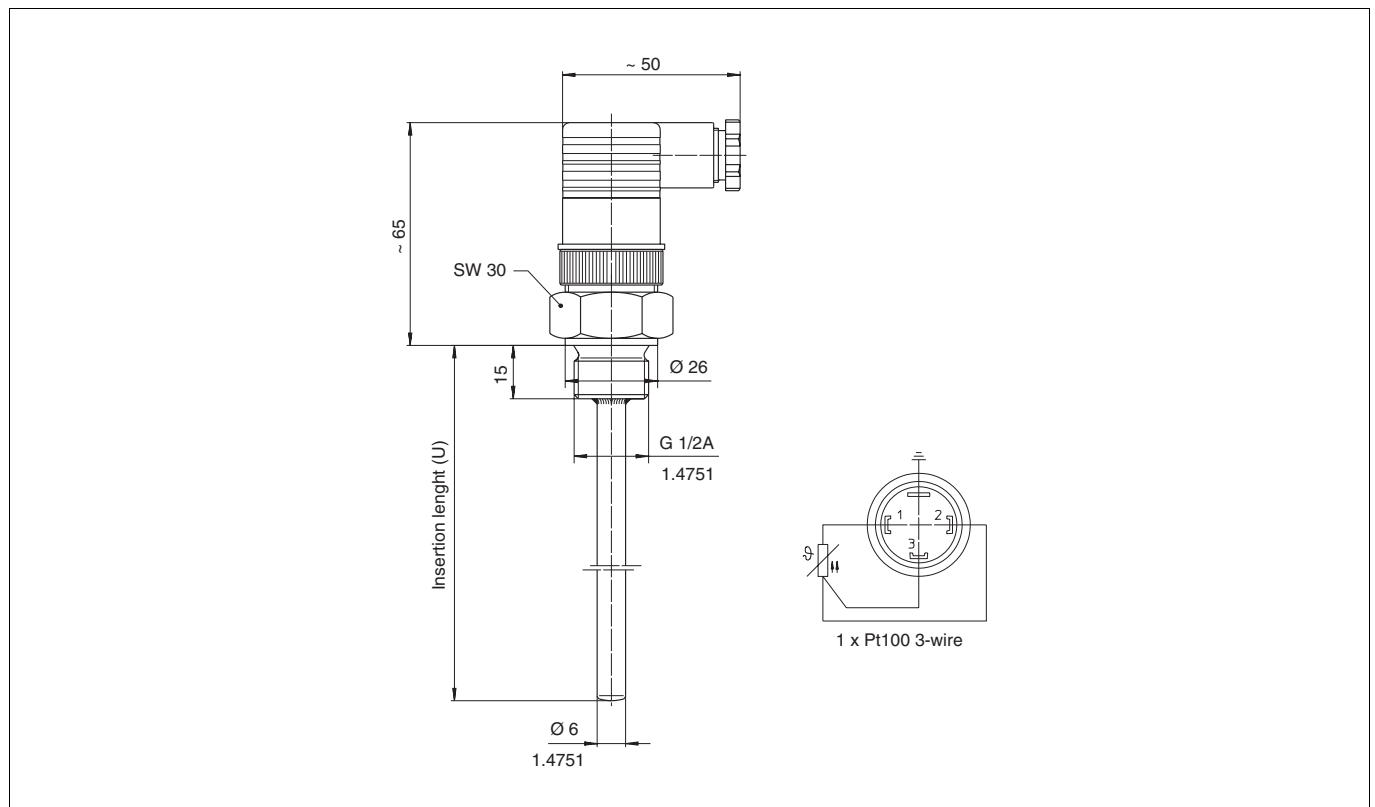

See page 12 for ordering details.

#### Standard, tolerance

EN 60751 (IEC 60751), Class B

#### Circuit type

3-wire

#### Measuring range

-50...+250 °C

#### Thermowell

Diameter 6 mm; material 1.4571

#### Mounting

Screwed plug, G1/2" thread to DIN 3852  
Type A, material 1.4571

#### Insertion length

60 mm or 100 mm

#### Electrical connection

Connector socket to DIN 43 650, type A,  
max. permissible temperature 125 °C

#### Cable entry

PG11

#### Degree of protection

IP 63

#### Response times

(Medium water,  $v = 0.3$  m/s)

$t_{0.5} = 3.7$  s;  $t_{0.9} = 8.8$  s

## Pipeline and air duct temperature sensor TSBA (BA R-200)

**Resistance thermometer for temperature measurement in pipelines and air ducts, with exchangeable measuring inset**

**Typical applications:**

**Water pipes, heating pipes, sewage pipes, air ducts, mechanical and environmental engineering**

**Technical data**

**Measuring winding**

1 x Pt 100

**Standard, tolerance**

EN 60751 (IEC 60751), Class B

**Circuit type**

3-wire

**Measuring range without integrated transmitter**

-50...+400 °C

**Transmitter**

Type TR04

**Measuring range of integrated transmitter**

-30...+60 °C or -20...+100 °C

**Thermowell**

Diameter 8 mm; material 1.4571

**Mounting**

see "Mounting accessories"

**Nominal length**

150 mm or 250 mm

**Measuring inset**

- exchangeable
- diameter 3 mm
- inset length = nominal length + 25 mm

**Connection head**

Without transmitter: Type B  
With transmitter: Type BH

**Cable entry**

Skintop PG13.5

**Degree of protection**

IP 66

### Dimensions, wiring diagrams

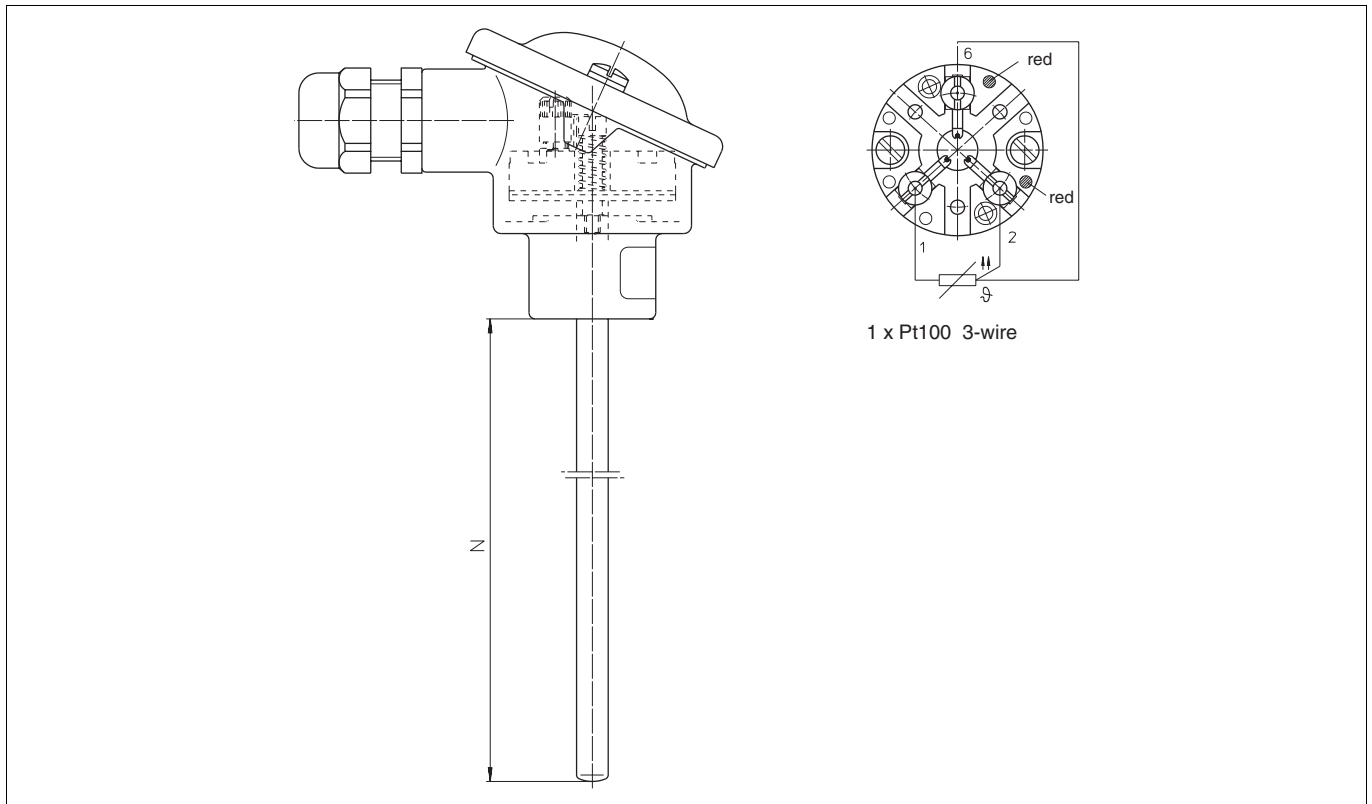

See page 12 for ordering details.

## Pipeline and air duct temperature sensor TSBA (BA R-250)

### Resistance thermometer for temperature measurement in pipelines and air ducts

Due to its special design providing for good vibration immunity, the TSBA (BA R-250) model is perfectly suited for mechanical engineering applications

#### Typical applications:

**Water pipes, heating pipes, sewage pipes, air ducts, mechanical and environmental engineering**

### Technical data

#### Measuring winding

1 x Pt 100

#### Standard, tolerance

EN 60751 (IEC 60751), Class B

#### Circuit type

3-wire

#### Measuring range without integrated transmitter

-50...+250 °C

#### Transmitter

Type TR04

#### Measuring ranges of the integrated transmitter

-30...+60 °C or -20...+100 °C

#### Thermowell

Diameter 8 mm; material 1.4571

#### Mounting

see "Mounting accessories"

#### Nominal length

100 mm, 150 mm, 250 mm or 400 mm

#### Connection head

Type B (also with integrated transmitter)

#### Cable entry

Skintop PG 13.5

#### Degree of protection

IP 66

### Dimensions, wiring diagrams

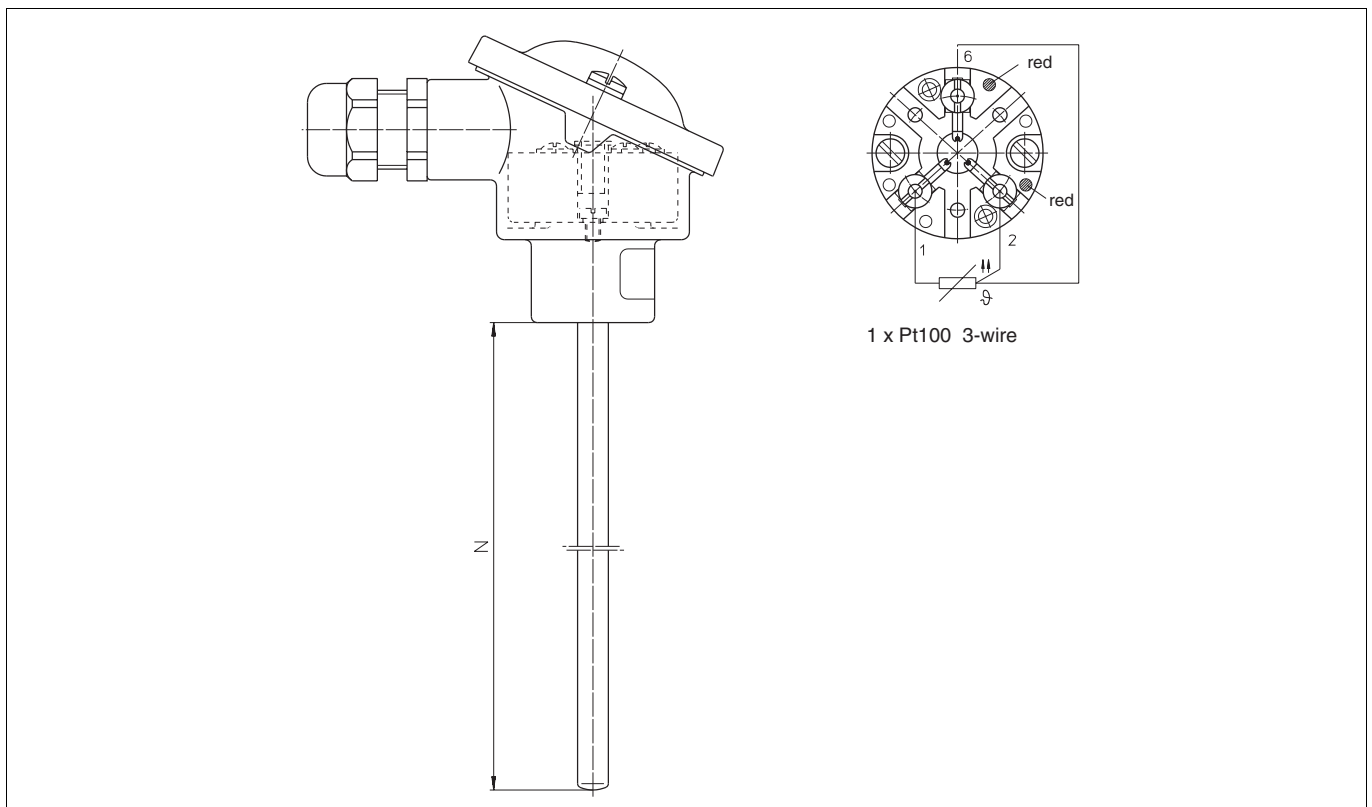

See page 12 for ordering details.

## Pipeline and air duct temperature sensor SensyTemp Quick

### Resistance thermometer for temperature measurement in pipelines and air ducts, with quick-release fasteners

The quick release fasteners save you 6 of the usually necessary 10 work steps and, thus, more than 50 % of the installation time.

For technical details and the ordering information please refer to data sheet 10/10-3.75 EN – SensyTemp Quick.

### Technical data of integrated transmitters

#### TR04

#### Output

##### Output current

4...20 mA temperature-linear

##### Current limiting

> 3.6 mA and ≤ 30 mA

##### Supply voltage $V_s$

10.5...30 V DC

##### Max. load

in the measuring range:

$$R_{Rmax} (\Omega) = \frac{V_s(V) - 10.5 V}{0.02 A}$$

with reliable sensor break signalling  
( $I_{max} < 26 \text{ mA}$ ,  $V_s = 30 \text{ V}$ )

##### Rise time ( $\tau_{90}$ )

< 0.5 s

##### Accuracy of drift values (percentage values related to the span)

##### Compensation uncertainty

If lower range value = 0 °C  
≤ 0.15 % or 0.15 K, the greater value applies

If lower range value < > 0 °C  
≤ 0.2 % or 0.2 K, the greater value applies

##### Linearity deviation

≤ 0,1%

#### Influence of ambient temperature

Lower range value, measuring span  
≤ 0.15 %/10 K or 0.15 K/10 K, the greater value applies

#### Electromagnetic compatibility

In accordance with NAMUR EMC (as of 2/88)

#### Gen. interference immunity for: Test circ. Standard Deviation

Transient overvoltage	2 Kv	IEC 801-4	< 0.5 %
Static discharge	8 KV	IEC 801-2	< 0.5 %
Electromagnetic fields	10 V/m	IEC 801-3	< 0.5 %

#### Influence of supply voltage

0.05 %/10 K (related to 20 V DC)

#### Influence of vibration

No influence (tested up to 35 g)

#### Error signalling

Sensor break > 22 mA  
Sensor line break > 22 mA  
Sensor short circuit < 3.0 mA  
Supply voltage, reversed polarity: 0 mA

### General data and safety data

#### Environmental capabilities

##### Storage temperature

-40...+20...+100 °C

##### Ambient temperature

-40...+20...+85 °C

##### Humidity

0...100 % relative humidity (with insulated sensor connection)

##### Power terminals

M 3.5

##### Weight

50 g (module)

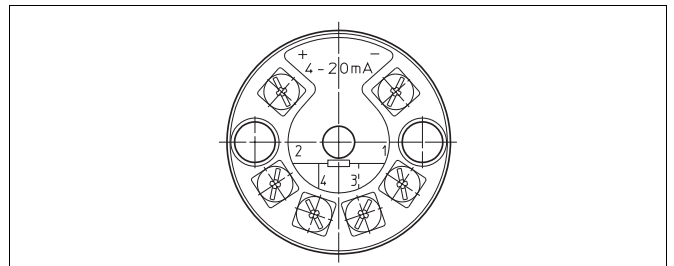

### Dimensional drawings

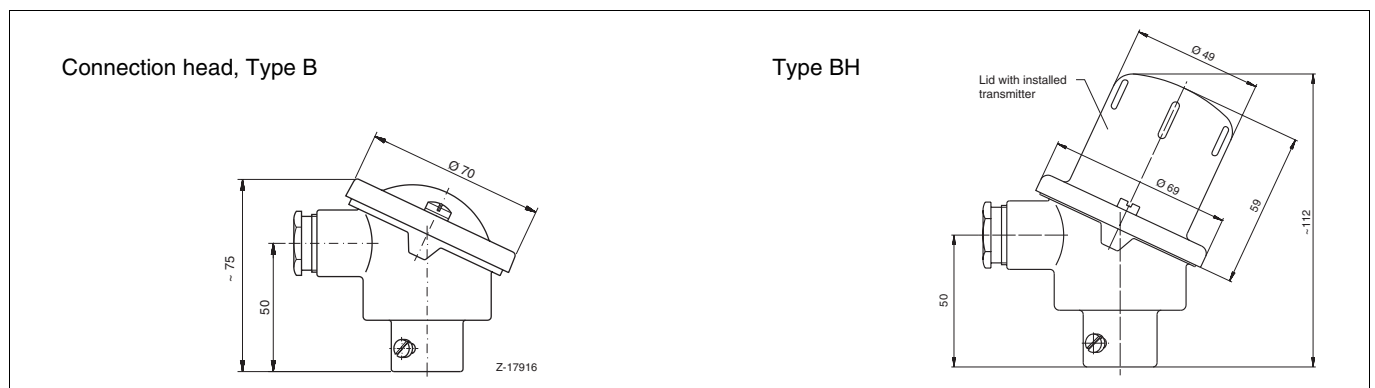

## Ordering Information

			Catalog No.		
TSBA (BA R-700)	1 x Pt 100, 4-wire circuit,		7962537		
TSBA (BA R-750)	1 x Pt 100, 2-wire circuit		220103		
	2 x Pt 100, 2-wire circuit		220104		
TSBA (BA R-500)	1 x Pt 100, 3-wire circuit		239925		
	1 x Pt 100, 3-wire circuit, with transmitter TR04	-30...+60 °C	239926		
TSBA (BA R-500-i)	1 x Pt 100, 3-wire circuit		240856		
	1 x Pt 100, 3-wire circuit, with transmitter TR04-Ex	-30...+60 °C	240857		
TSBA (BA R-300)	1 x Pt 100, 2-wire circuit				
	Insertion length 200 mm		7962541		
	Insertion length 330 mm		7962542		
	1 x Pt 100, 2-wire circuit, with transmitter TR04	-30...+60 °C			
	Insertion length 200 mm		7962544		
	Insertion length 330 mm		7962545		
TSBA (BA R-900)	1 x Pt 100, 2-wire circuit				
	Active length 6000 mm		7962547		
	Active length 10000 mm		7962548		
	1 x Pt 100, 2-wire circuit with transmitter TR04	-30...+60 °C			
	Active length 6000 mm		7957661		
	Active length 10000 mm		7957664		
	1 x Pt 100, 2-wire circuit with transmitter TR04	-20...+40 °C			
	Active length 6000 mm		7962549		
	Active length 10000 mm		7962550		
TSBA (BA R-150)	1 x Pt 100, 3-wire circuit				
	Insertion length 60 mm		238590		
	Insertion length 100 mm		238591		
TSBA (BA R-200)	1 x Pt 100, 3-wire circuit, measuring inset exchangeable				
	Nominal length 150 mm		240427		
	Nominal length 250 mm		240428		
	1 x Pt 100, 3-wire circuit with transmitter TR04	-30...+ 60 °C			
	Nominal length 150 mm		240429		
	Nominal length 250 mm		240430		
	1 x Pt 100, 3-wire circuit with transmitter TR04	-20...+100 °C			
	Nominal length 150 mm		240431		
	Nominal length 250 mm		240432		
TSBA (BA R-250)	1 x Pt 100, 3-wire circuit				
	Nominal length 100 mm		240840		
	Nominal length 150 mm		240841		
	Nominal length 250 mm		240842		
	Nominal length 400 mm		240843		
	1 x Pt 100, 3-wire circuit with transmitter TR04	-30...+ 60 °C			
	Nominal length 100 mm		240844		
	Nominal length 150 mm		240845		
	Nominal length 250 mm		240846		
	Nominal length 400 mm		240847		
	1 x Pt 100, 3-wire circuit with transmitter TR04	-20...+100 °C			
	Nominal length 100 mm		240848		
	Nominal length 150 mm		240849		
	Nominal length 250 mm		240850		
	Nominal length 400 mm		240851		

Continued on next page

Other versions on request

**Ordering Information (continued)**

	Catalog No.		
<b>Accessories</b>			
Adjustable compression fitting for TSBA (BA R-200), TSBA (BA R-250)			
thread size G 1/2 A      material galv. Steel	230646		
thread size G 1/2 A      material stainless steel	228302		
thread size 1/2" NPT    material stainless steel	238451		
thread size M18x1.5    material galv. Steel	222024		
Adjustable sheet metal flange (chromised) for TSBA (BA R-200), TSBA (BA R-250)	233889		
1 package mounting clamps for TSBA (BA R-900) (5 pcs. per package)	242804		

Other versions on request

**Mounting accessories**

**for TSBA (BA R-200, BA R-250)**

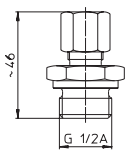

Adjustable compression fitting  
 Cylindrical thread, G 1/2 A  
 Material steel, galvanized / steel clamp ring  
 Material stainless steel

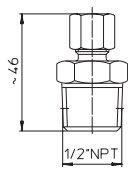

Adjustable compression fitting  
 Conical thread, 1/2" NPT  
 Material stainless steel

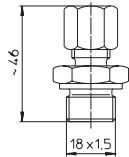

Adjustable compression fitting  
 Cylindrical thread, M18 x 1.5  
 Material steel, galvanized / steel clamp ring

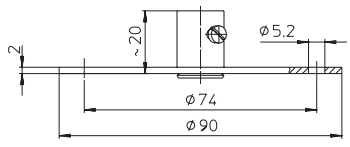

Adjustable sheet metal flange  
 Diameter 90 mm, chromated

**for TSBA (BA R-900)**

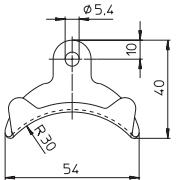

Mounting clamp, copper,  
 Min. quantity to be ordered: 10 pieces

---

The Industrial<sup>IT</sup> wordmark and all mentioned product names in the form XXXXX<sup>IT</sup> are registered or pending trademarks of ABB.

ABB has Sales & Customer Support expertise in over 100 countries worldwide.

[www.abb.com](http://www.abb.com)

The Company's policy is one of continuous product improvement and the right is reserved to modify the information contained herein without notice.

Printed in the Fed. Rep. of Germany (05.04)

© ABB 2004



**ABB Ltd.**  
Salterbeck Trading Estate  
Workington, Cumbria  
CA14 5DS  
UK  
Tel: +44 (0)1946 830 611  
Fax: +44 (0)1946 832 661

**ABB Inc.**  
125 E. County Line Road  
Warminster, PA 18974  
USA  
Tel: +1 215 674 6000  
Fax: +1 215 674 7183

**ABB Automation Products GmbH**  
Borsigstr. 2  
63755 Alzenau  
Germany  
Tel: +49 551 905-534  
Fax: +49 551 905-555