

TF 212 / TF 212-Ex

Field mounted
temperature transmitters,
PROFIBUS PA,
Pt 100 (RTD), thermocouples,
1 or 2 independent channels

10/11-8.70 EN



■ Input

- Resistance thermometer (2, 3, 4-wire method)
- Thermocouples
- Resistor remote signalling units (0...400 Ω, 0...4000 Ω)
- Voltages, mV (-15...115 mV)

■ Electrical isolation (I/O)

■ Digital, long-term solid processing of measuring values

■ Customer-specific linearization

■ Continuous sensor and self-monitoring

■ Explosion protection approvals:

- Intrinsic safety Ex II 2 G EEx ia IIC T6
- Flameproof version: ATEX
- Explosion Proof version (acc. to divisions): FM, CSA

■ Output

- PROFIBUS PA profile V3.0, Type A and B
- Bus design acc. to IEC 1158-2, 31.25 kbit/s

■ Input functionality

- 1 or 2 channels
- Redundancy
- Average value
- Differential value

■ EMC acc. to EN 50082-2 and NAMUR recommendation NE 21

■ Reverse voltage protection and solid bus current limitation

■ Parameterization

- DTM for FDT 0.98-1 Interface and SMART VISION
- Siemens Simatic PDM driver for TF 12 / TF 212

Technical data

Output

Digital output signal	PROFIBUS PA profile V3.0 type A and B
Transmission rate (Baud rate)	31.25 kbit/s
Nominal current consumption	11.8 mA
Max. current in case of device failure	15 mA
Damping (programmable)	$t_{63} = 0...60$ s

Input

Resistance (temperature linear)

Resistance thermometer	Pt 50...Pt 100...Pt 1000
Resistance	0...400 Ω / 0...4000 Ω
Line resistance (R_W) per core	< 5 Ω
Measuring current	200 μ A
Sensor short-circuit	< 5 Ω (for RTD)
Sensor break	> 5 M Ω

Thermocouples

Types	B, C, D, E, J, K, L, N, R, S, T, U
-------	------------------------------------

Voltages

	-15 mV...115 mV
Sensor monitoring current	200 μ A
Input resistance	5 M Ω
Input filter	50/60 Hz
Internal reference junction	Pt 100, programmable

Power supply (at transmitter terminals)

Supply voltage, poling protected $U_s = 9...32$ V DC
for explosion protection application $U_i = 9...17.5$ V DC

General characteristics

Rise time	< 0.1...1.25 s
Vibration resistance	
Vibration in operation	2 g acc. to DIN IEC 68 part 2-6
Electrical isolation (I/O)	1.5 kV

Environment conditions

Ambient temperature range	-40...85 $^{\circ}$ C
Transport and storage temperature	-40...100 $^{\circ}$ C
Relative humidity	< 100 % (100 % humidity with isolated terminals only)
Condensation	permitted

Characteristics at rated conditions¹⁾

(acc. to IEC 770, related to 25 $^{\circ}$ C)

Measuring error incl. characteristic deviation	
Pt 100/resistance measurement	typ. < 0.2 % min. < 0.2 K
Thermocouple/mV	typ. < 20 μ V
Additional influence of the internal reference junction	Pt 100 DIN IEC 751 cl. B

Mechanical construction

Housing material	aluminium / stainless steel
Type of protection	IP 66 and IP 67
Color (EPOXY)	light grey (RAL 9002)
Weight	1.25 kg (without accessories)

Electrical connection

Thread	M20 x 1.5 1/2" NPT, 3/4" NPT, 1/2" GK
Cable glands (cable \varnothing 3,5...8,7 mm)	cf. ordering information
Ground screw ext./int.	6 mm ² M5 / 2.5 mm ² M4
Terminals	2.5 mm ² , screw terminals

¹⁾ Percentage related to measuring range

Input element		Measuring range	Basis Measuring error
Standard	Sensor		
IEC 584-1	Thermocouple Type B	400...+1820 $^{\circ}$ C (752...+3308 $^{\circ}$ F)	0.8 K
	Thermocouple Type E	-100...+1000 $^{\circ}$ C (-148...+1832 $^{\circ}$ F)	0.2 K
	Thermocouple Type J	-100...+1200 $^{\circ}$ C (-148...+2192 $^{\circ}$ F)	0.2 K
	Thermocouple Type K	-180...+1370 $^{\circ}$ C (-292...+3200 $^{\circ}$ F)	0.2 K
	Thermocouple Type R	- 50...+1760 $^{\circ}$ C (- 58...+3200 $^{\circ}$ F)	0.8 K
	Thermocouple Type S	- 50...+1760 $^{\circ}$ C (- 58...+3200 $^{\circ}$ F)	0.8 K
	Thermocouple Type T	-200...+ 400 $^{\circ}$ C (-328...+ 752 $^{\circ}$ F)	0.2 K
	Thermocouple Type N	-180...+1300 $^{\circ}$ C (-292...+2372 $^{\circ}$ F)	0.2 K
W3, ASTM E 998	Thermocouple Type C	0...+2300 $^{\circ}$ C (32...+4172 $^{\circ}$ F)	0.2 K
	Thermocouple Type D	0...+2300 $^{\circ}$ C (32...+4172 $^{\circ}$ F)	0.2 K
DIN 43710	Thermocouple Type L	-100...+ 900 $^{\circ}$ C (-148...+1652 $^{\circ}$ F)	0,8 K
	Thermocouple Type U	-200...+ 600 $^{\circ}$ C (-328...+1112 $^{\circ}$ F)	0,8 K
IEC 751 ¹⁾	Resistance thermometer Pt 100	-200...+ 850 $^{\circ}$ C (-328...+1562 $^{\circ}$ F)	0.4 K
	Resistance thermometer Pt 1000	-200...+ 850 $^{\circ}$ C (-328...+1562 $^{\circ}$ F)	0.4 K
	Resistance thermometer Pt 100/ PT 1000	-100...+ 250 $^{\circ}$ C (-148...+ 482 $^{\circ}$ F)	0.2 K
DIN 43760 (a = 0,00618)	Resistance thermometer Ni 100	- 60...+ 250 $^{\circ}$ C (- 76...+ 482 $^{\circ}$ F)	0.2 K
Resistance	2, 3, 4-wire	0...400 Ω , 0...4000 Ω	0.10 %
Voltage		-15 mV...115 mV	20 μ V

¹⁾ a=0,00385

Technical data

Explosion protection

Intrinsically safe (ATEX) ⊕ II 2 G EEx ia IIC T6
 EC certificate ZELM 99 ATEX 0021
 Temperature class T6/T4 < 60°C/85 °C

Suitable for connecting to fieldbus systems according to
 – FISCO model

Supply circuit	Output [ib]	Input [ia]
Max. voltage	$U_i < 17.5 \text{ V}$	$U_o < 5.9 \text{ V}$
Short-circuit current	$I_i < 360 \text{ mA}$	$I_o < 17 \text{ mA}$
Max. power	$P_i < 2.52 \text{ W}$	$P_o < 26 \text{ mW}$
Internal inductance	$L_i < 10 \mu\text{H}$	neglectable
Internal capacitance	$C_i = 1.2 \text{ nF}$	neglectable

Pressure-proof encapsulated

ATEX (PTB) ⊕ II 2 G EEx d IIC T6
 Temperature class T6/T5/T4 <50 °C/65 °C/85 °C
 EC certificate ZELM 99 ATEX 1144

Explosion Proof certification (FM/CSA) acc. to divisions
 Class I, Div. 1/Div. 2, Group A, B, C, D T6
 Class II, Div. 1/Div. 2, Group E, F, G T5
 Class III, T6

Electromagnetic compatibility (EMC)

Acc. to NAMUR NE 21 recommendation
 With Pt 100 sensor

Type of test	Degree	IEC
burst to signal/ data lines	1 kV	EN 61000-4-4 EN 50082-2
static discharge contact discharge to: contact plate terminals for supply	8 kV 6 kV	EN 61000-4-2
radiated field 80 MHz...1 GHz	10 V/m	EN 61000-4-3
coupling 150 kHz - 80 MHz	10 V	EN 61000-4-6

Parameterization/structure

Type of inputs (2 independent channels), measuring range, input filter, damping, alarm function, limit values, compensation for ageing, saving of all data proof against mains failure.

Standard parameters (factory setting)

Channel 1
 Pt 100, 3-wire circuit
 L-L/L/H/H-H-Lim = -200 °C/200 °C/850 °C/850 °C
 damping 0 s, unit °C

Channel 2
 Pt 100, 3-wire circuit
 L-L/L/H/H-H-Lim = -200 °C/200 °C/850 °C/850 °C
 dampingn 0 s, unit °C

Default address
 126

Process Control System (PCS)

A cyclic communication can be established with all PROFIBUS compatible PCSs. Acyclic communication requires a Master CI. 2, the communication may be established on the basis of the generic slave (to be in acc. to Profile 3.0; only standard parameters) or a TF 12 specific driver. Those drivers are available for following PCSs:
 – Freelance 2000/Control Builder F (DTM or template)
 – Symphony (Composer via DTM)
 – Siemens (via PDM)

Configuration-tools

– DTM for FDT 0.98-1 Interface and SMART VISION
 – Siemens Simatic PDM driver for TF 12 / TF 212

Block diagram

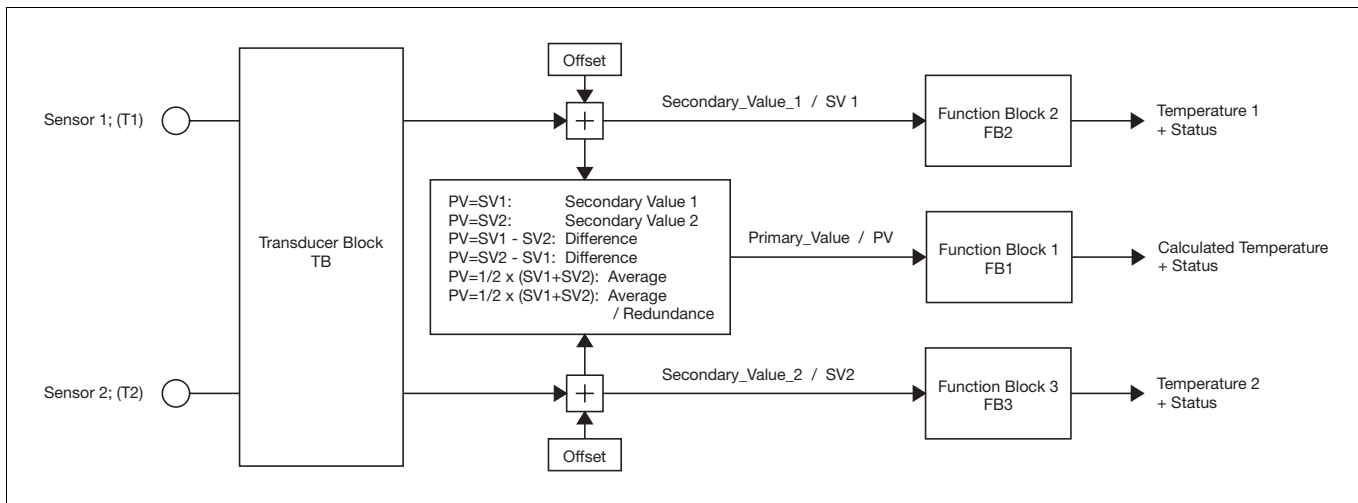

Communication/Parameterization

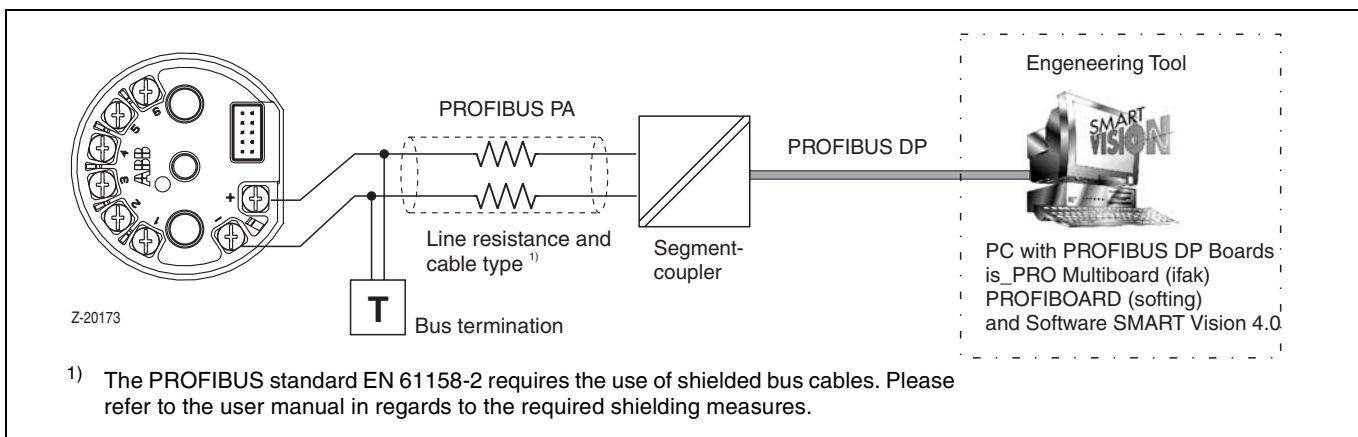

Ordering information		Catalog No.	
TF 212 / TF 212-Ex	V11524-		
Without explosion protection TF 212 without explosion protection	1		
With explosion protection Type of protection: intrinsic safety TF 212-Ex Zelm / ATEX II 2 G EEx ia IIC T6 (Zone 1)	5		
Type of protection: pressure-proof enclosure / explosion-proof TF 212-Ex d PTB / ATEX II 2 G EEx d IIC T6	D		
TF 212-Ex d FM / CSA Class I, Div. 1/Div. 2, Groups A, B, C, D T6	E		
Class II, Div. 1/Div. 2, Groups E, F, G T6			
Class III T6			
Display / construction AGLF-housing without display	N		
Material Aluminium	A		
Stainless steel	E		
Connections with cable screw connections / PA-connector 2 pieces: M 20 x 1.5 or pressure-proof ¹⁾ M-connector for PROFIBUS PA (Turck) and M 20 x 1.5 M-connector for PROFIBUS PA (Weidmüller) and M 20 x 1.5 Thread (without cable-screw-connection) M20 x 1.5 1/2" NPT 3/4" NPT 1/2" GK	N T W 1 2 3 4		
Mounting field housing without Wall mounting (carbon steel) Wall mounting (stainless steel) 2" Pipe mounting (carbon steel) 2" Pipe mounting (stainless steel)	1 2 3 4 5		
Programming Factory standard parameter default address 126 Channel 1: Pt100, 3 wire circuit, damping off, unit °C L-L // L / H // H-H = -200 °C // 200 °C / 850 °C // 850 °C Channel 2: Pt100, 3 wire circuit, damping off, unit °C L-L // L / H // H-H = -200 °C // 200 °C / 850 °C // 850 °C Customer-specified parameter definition (all parameter without user curve) Extended customer-specified parameter definition (all parameter including user curve)	S K L		
Accessories		Catalog No.	
SMART VISION Software (minimum 4.01 req.) and DTM TF 12 / TF 212	s. Data Sheet 10/63-1.20 EN		
Device driver TF 12 / TF 212 for Siemens Simatic PDM software (from V5.02+SP1)	7957848		

¹⁾ Metal screw connection EEx e or EEx d (cable-diameter 3.5...8.7 mm)

Connection diagram

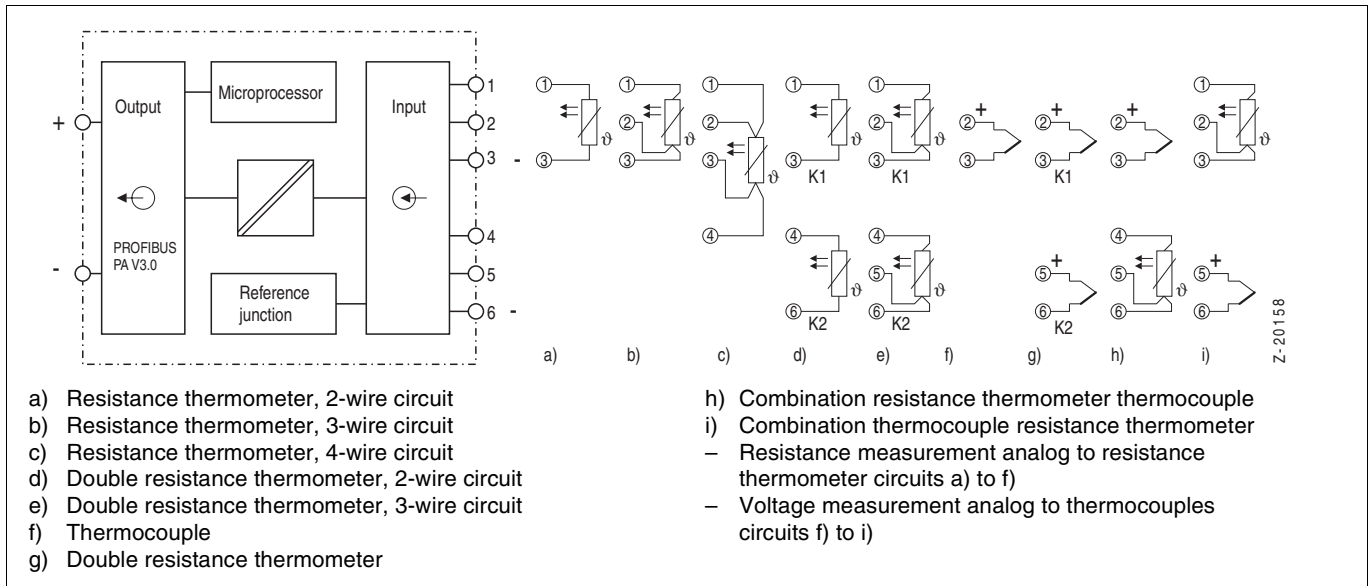

Dimensional diagram (all dimensions in mm)

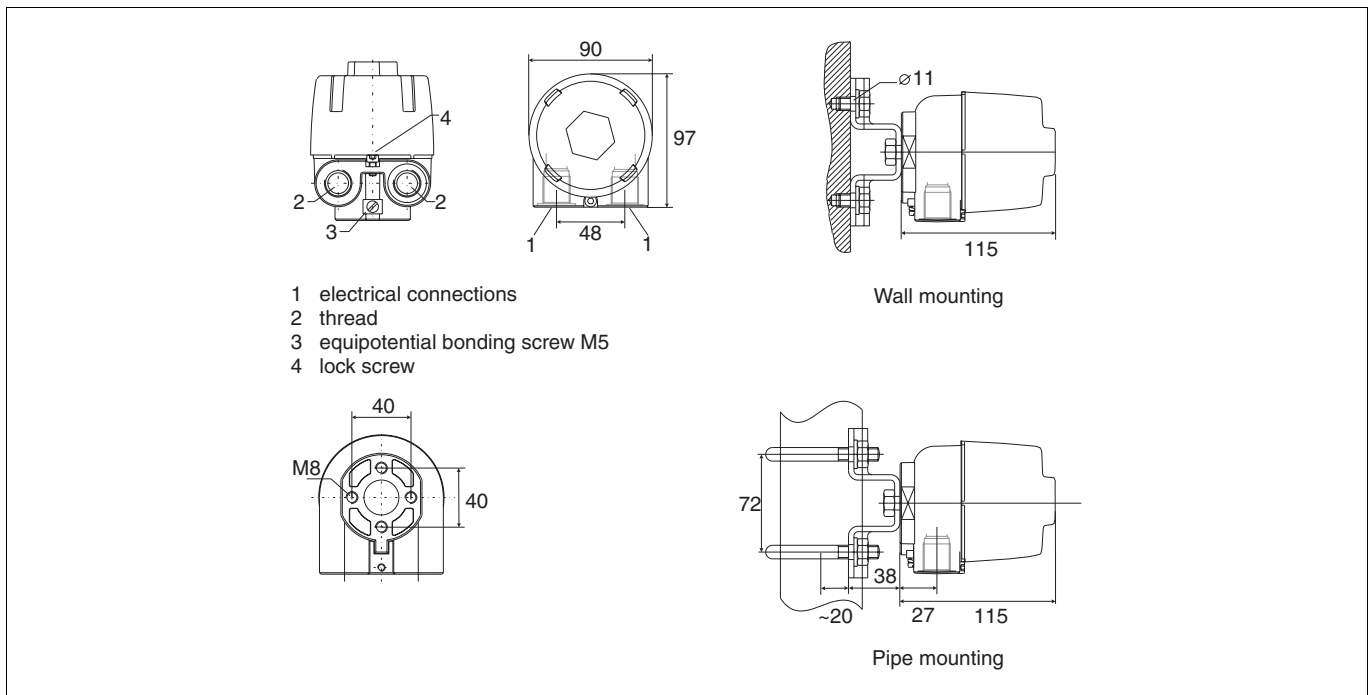

ABB Automation Products GmbH

Borsigstr. 2
 63755 Alzenau
 Germany
 Tel: +49 6023 92-0
 Fax: +49 6023 92-3430
 http://www.abb.com

Subject to technical changes.
 Printed in the Fed. Rep. of Germany
 Data Sheet 10/11-8.70 EN 05.02