

**HART,
Pt100 (RTD), thermocouples,
electrical isolation**

■ Input

- Resistance thermometer (2-, 3-, 4-wire circuit)
- Thermocouples
- Resistance-type transmitter (0 ... 5000 Ω)
- Voltages, mV transmitter (-125 ... 1100 mV)

■ Input functionality

- 1 or 2 sensors (e.g. 2 x Pt100 3-L)
- Sensor backup/redundancy

■ Output

- 2-wire technique
- 4 ... 20 mA temperature linear
- HART signal

■ Measurement error

- 0,1 K

■ Specific linearization

- Callendar van Dusen coefficients
- Table of variate pairs / 32 points

■ Continuous sensor and self-monitoring

- Supply voltage monitoring
- Wire break and corrosion monitoring (NE 89)
- Extended diagnostics (NE 107)

■ Device safety in accordance with NE 53, NE 79

■ Approvals for explosion protection

- intrinsically safe: ATEX EEx ia (Zone 0), FM, CSA
- nonincendive: ATEX EEx n A
- Dust-ignition proof: ATEX / Zone 20
- air tight: ATEX / Zone 1, FM, CSA

■ Configuration

- Display with TTF300 configuration options
- FDT / DTM
- SMART VISION DSV401



**Sensor adjustment
Redundancy 2 x Pt100 3-L
Extended diagnostic functions**

Contents

1	Technical data	3
1.1	Input.....	3
1.2	Output.....	3
1.3	Power supply (polarity safe).....	4
2	General information	4
2.1	Ambient conditions	4
2.2	Electromagnetic compatibility.....	4
2.3	Interference immunity.....	4
2.4	Measurement accuracy	5
2.5	Operating conditions	7
3	Mechanical design	8
4	Communication	9
5	Explosion-protection relevant information	10
5.1	TTF300-E1... (intrinsically safe).....	10
5.2	TTF300-E2... (nonincendive).....	10
6	Approvals	11
6.1	TTF300.....	11
7	LC display	12
7.1	Features of LC display	12
7.2	Configuration function of LC display	12
7.3	LC display HMI ignition-proof type A (intrinsically safe).....	12
8	Terminal connection diagrams	13
9	Dimensioned drawing	15
9.1	TTF300.....	15
10	Ordering information	16
11	Order form configuration	18

1 Technical data

1.1 Input

1.1.1 Resistance

RTD resistance thermometer

Pt100 in accordance with DIN IEC 60751, JIS, MIL, Ni in accordance with DIN 43760, Cu (for additional information, see the section "Measurement accuracy")

Resistance measurement

0 ... 500 Ω
0 ... 5000 Ω

Sensor connections

2-, 3-, 4-wire circuit

Connecting cables

2-, 3-, 4-wire max. sensor line resistance (R_W) for each wire 50 Ω in accordance with NE 89 (March 2003);

(3-wire balanced, 2-wire circuit compensation up to 100 Ω sensor total line resistance)

Measurement current

< 300 μ A

Sensor short-circuit

< 5 Ω (for RTD)

Sensor wire break (temperature resistance measurement 2-, 3-, 4-wire)

Measuring range 0 ... 500 Ω > 0.6 ... 10 k Ω
Measuring range 0 ... 5 k Ω > 5.3 ... 10 k Ω

Corrosion detection in accordance with NAMUR NE 89

3-wire resistance reading > 50 Ω
4-wire resistance reading > 50 Ω

1.1.2 Thermocouples/Voltages

Types

B, E, J, K, L, N, R, S, T, U, C, D
(see "Measurement accuracy")

Voltages

-125 mV ... 125 mV
-125 mV ... 1100 mV

Connecting cables

Max. sensor line resistance (R_W) for each line 1.5 k Ω , total 3 k Ω

Sensor wire break monitoring in accordance with Namur NE 89

pulsed with 1 μ A outside the measurement interval
Thermocouple measurement 5.3 ... 10 k Ω with 45% hysteresis
Voltage measurement 5.3 ... 10 k Ω with 45% hysteresis

Input resistance

> 10 M Ω

Internal reference junction

Pt100, DIN IEC 60751 Cl. B
(no jumpers necessary)

Freestyle characteristics and 32-point sampling table

Resistance measurement up to max. 5 k Ω
Voltages up to max. 1.1 V

Sensor matching

via Callendar van Dusen coefficients
via table of 32 sampling points
via single point (offset adjustment)
via two point adjustment

Input functionality

1 Sensor
2 Sensors:
mean measurement
Differential measurement: Zero point where $I_a = 4$ mA
Differential measurement: Zero point where $I_a = 12$ mA
Sensor redundancy

Sensor fault signaling

RTD sensor: Short circuit and wire break
Linear resistance measurement: Wire break
Thermocouple: Wire break
Linear voltage measurement: Wire break

1.2 Output

Transmission characteristics

temperature linear
resistance linear
voltage linear

Output signal

Configurable 4 ... 20 mA (standard)
Configurable 20 ... 4 mA
(NE43 dynamic range: 3.8 ... 20.5 mA)

Simulation mode

3.5 ... 23.6 mA

Induced current consumption

< 3.5 mA

Maximum output current

23.6 mA

Configurable error current signal

override 22 mA (20.0 ... 23.6 mA)
underdrive 3.6 mA (3.5 ... 4.0 mA)

Two configurable warning limits

HART-Signal/diagnostic bit information

Two configurable alarm limits

HART-Signal/diagnostic bit information

1.3 Power supply (polarity safe)

(2-wire technique; power lines = signal lines)

Supply voltage

Non ignition-proof application with or without LC display:

$$U_s = 11 \dots 42 \text{ V DC}$$

Ignition-proof applications with or without LC display:

$$U_s = 11 \dots 30 \text{ V DC}$$

Max. permissible residual ripple for supply voltage

Max. permissible ripple for supply voltage during communication in accordance with HART FSK "Physical Layer" specification, version 8.1 (08/1999) Section 8.1

Undervoltage detection

$$U_{\text{Terminal-Mu}} < 10 \text{ V results in } I_a = 3.6 \text{ mA}$$

Max. load

$$R_{\text{load}} = (\text{supply voltage: } 11 \text{ V})/0.022 \text{ A}$$

Max. load (W) depending on supply voltage (V DC)

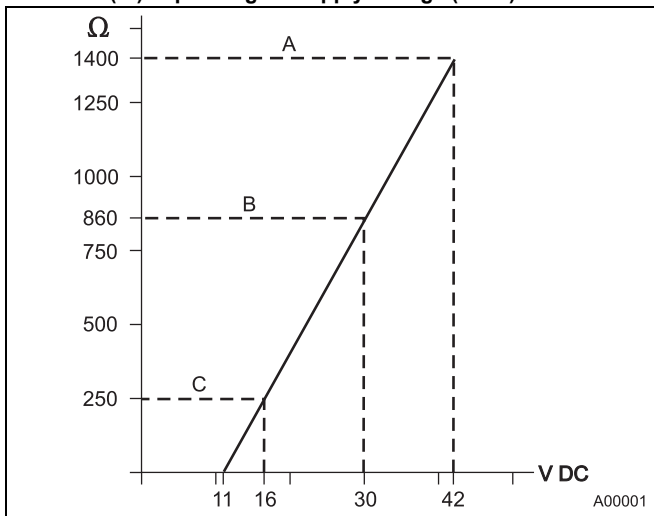

Fig. 1

- A TTF300,
- B TTF300 in EEx ia design
- C HART communication resistance

Max. power consumption

$$P = U_s \times 0.022 \text{ mA}$$

e.g., $U_s = 24 \text{ V} \rightarrow P_{\text{max}} = 0.528 \text{ W}$

2 General information

Galvanic isolation (input/output)	3.5 kV AC (approx. 2.5 kV DC) 60 s
MTBF time	28 years at 60 °C ambient temperature
Input filter	50 / 60 Hz
Switch-on delay	< 10 s ($I_a \leq 3.6 \text{ mA}$ during starting cycle)
Warm-up time	5 min.
Ramp-up time t90	150 ... 600 ms
Update reading ¹⁾	10/s with 1 sensor, 5/s with 2 sensors
Output filter	Digital filter 1st order: 0 ... 100 s

¹⁾ depending on sensor type and sensor circuit

2.1 Ambient conditions

Ambient temperature:

Standard: -40 ... 85 °C / -40 ... 185 °F

Optional: -50 ... 85 °C / -58 ... 185 °F

For use with LC display HMI type A:

-20 ... 70 °C / -4 ... 158 °F

For ignition-proof design, see prototype test certificate PTB 05 ATEX 2079 X.

Storage temperature: -40 ... 85 °C / -40 ... 185 °F

Climate class: Cx (-40 ... 85 °C / -40 ... 185 °F, 5 ... 95% relative humidity) DIN EN 60654-1

Max. permissible humidity: 100% relative humidity, condensation permitted in accordance with IEC 68-2-6

Vibration resistance: 10 ... 2000 / 5 Hz acc. to IEC 68-2-6

Shock: gn = 30 in accordance with IEC 68-2-27

Earthquake resistance: Acc. to EN1473

Salt fog: Acc. to IEC 68-2-11

Type of protection: IP66 and IP67; NEMA 4X, ENCL 4X

2.2 Electromagnetic compatibility

Emitted interference in accordance with IEC 61326 (2002) and Namur NE21 (02/2004)

2.3 Interference immunity

Interference immune in accordance with IEC 61326 (2002) and Namur NE21 (02/2004)

Pt100: Measuring range 0 ... 100 °C, span 100 K

Type of test	Testing accuracy	Influence
Burst to signal/data lines	2 kV	< 0.5%
Static discharge		
• Contact plate (indirect)	8 kV	no
• Supply terminals ¹⁾	6 kV	no
• Sensor terminals ¹⁾	4 kV	no
Radiated field		
80 MHz ... 2 GHz	10 V/m	< 0.5%
Coupling		
150 kHz ... 80 MHz	10 V	< 0.5%
Surge		
between the lines	0.5 kV	no malfunction
Line to earth	1 kV	no malfunction

¹⁾ Air discharge (at 1 mm distance)

2.4 Measurement accuracy

Includes linearity deviation, reproducibility/hysteresis at 23 °C ± 5 K

Information on measurement accuracy corresponds to 3 σ (Gaussian distribution)

Input element		Measuring range limits	Minimum span	Digital accuracy (24-bit A/D converter)	D/A accuracy ¹⁾ (1 6-bit DA)
Standard	Sensor				
Resistance sensors/potentiometer					
DIN IEC 60 751	RTD Pt10 (a=0.003850)	-200 ... 850 °C / -328 ... 1562 °F	10 °C / 18 °F	± 0.80 °C / ± 1.44 °F	± 0.05 %
	RTD Pt50 (a=0.003850)	-200 ... 850 °C / -328 ... 1562 °F	10 °C / 18 °F	± 0.16 °C / ± 0.29 °F	± 0.05 %
	RTD Pt100 (a=0.003850) ²	-200 ... 850 °C / -328 ... 1562 °F	10 °C / 18 °F	± 0.08 °C / ± 0.14 °F	± 0.05 %
	RTD Pt200 (a=0.003850)	-200 ... 850 °C / -328 ... 1562 °F	10 °C / 18 °F	± 0.24 °C / ± 0.43 °F	± 0.05 %
	RTD Pt500 (a=0.003850)	-200 ... 850 °C / -328 ... 1562 °F	10 °C / 18 °F	± 0.16 °C / ± 0.29 °F	± 0.05 %
	RTD Pt1000 (a=0.003850)	-200 ... 850 °C / -328 ... 1562 °F	10 °C / 18 °F	± 0.08 °C / ± 0.14 °F	± 0.05 %
JIS C1604-81	RTD Pt10 (a=0.003916)	-200 ... 645 °C / -328 ... 1193 °F	10 °C / 18 °F	± 0.80 °C / ± 1.44 °F	± 0.05 %
	RTD Pt50 (a=0.003916)	-200 ... 645 °C / -328 ... 1193 °F	10 °C / 18 °F	± 0.16 °C / ± 0.29 °F	± 0.05 %
	RTD Pt100 (a=0.003916)	-200 ... 645 °C / -328 ... 1193 °F	10 °C / 18 °F	± 0.08 °C / ± 0.14 °F	± 0.05 %
MIL-T-24388	RTD Pt10 (a=0.003920)	-200 ... 850 °C / -328 ... 1562 °F	10 °C / 18 °F	± 0.80 °C / ± 1.44 °F	± 0.05 %
	RTD Pt50 (a=0.003920)	-200 ... 850 °C / -328 ... 1562 °F	10 °C / 18 °F	± 0.16 °C / ± 0.29 °F	± 0.05 %
	RTD Pt100 (a=0.003920)	-200 ... 850 °C / -328 ... 1562 °F	10 °C / 18 °F	± 0.08 °C / ± 0.14 °F	± 0.05 %
	RTD Pt200 (a=0.003920)	-200 ... 850 °C / -328 ... 1562 °F	10 °C / 18 °F	± 0.24 °C / ± 0.43 °F	± 0.05 %
	RTD Pt1000 (a=0.003920)	-200 ... 850 °C / -328 ... 1562 °F	10 °C / 18 °F	± 0.08 °C / ± 0.14 °F	± 0.05 %
DIN 43760	RTD Ni50 (a=0.006180)	-60 ... 250 °C / -76 ... 482 °F	10 °C / 18 °F	± 0.16 °C / ± 0.29 °F	± 0.05 %
	RTD Ni100 (a=0.006180)	-60 ... 250 °C / -76 ... 482 °F	10 °C / 18 °F	± 0.08 °C / ± 0.14 °F	± 0.05 %
	RTD Ni120 (a=0.006180)	-60 ... 250 °C / -76 ... 482 °F	10 °C / 18 °F	± 0.08 °C / ± 0.14 °F	± 0.05 %
	RTD Ni1000 (a=0.006180)	-60 ... 250 °C / -76 ... 482 °F	10 °C / 18 °F	± 0.08 °C / ± 0.14 °F	± 0.05 %
	RTD Cu10 (a=0.004270)	-50 ... 200 °C / -58 ... 392 °F	10 °C / 18 °F	± 0.80 °C / ± 1.44 °F	± 0.05 %
	RTD Cu100 (a=0.004270)	-50 ... 200 °C / -58 ... 392 °F	10 °C / 18 °F	± 0.08 °C / ± 0.14 °F	± 0.05 %
	Resistance measurement	0 ... 500 Ω	4 Ω	± 32 mΩ	± 0.05 %
	Resistance measurement	0 ... 5000 Ω	40 Ω	± 320 mΩ	± 0.05 %
Thermocouples³⁾/voltages					
IEC 584	Type K (Ni10Cr-Ni5)	-270 ... 1372 °C / -454 ... 2502 °F	50 °C / 90 °F	± 0.35 °C / ± 0.63 °F	± 0.05 %
	Type J (Fe-Cu45Ni)	-210 ... 1200 °C / -346 ... 2192 °F	50 °C / 90 °F	± 0.35 °C / ± 0.63 °F	± 0.05 %
	Type N (Ni14CrSi-NiSi)	-270 ... 1300 °C / -454 ... 2372 °F	50 °C / 90 °F	± 0.35 °C / ± 0.63 °F	± 0.05 %
	Type T (Cu-Cu45Ni)	-270 ... 400 °C / -454 ... 752 °F	50 °C / 90 °F	± 0.35 °C / ± 0.63 °F	± 0.05 %
	Type E (Ni10Cr-Cu45Ni)	-270 ... 1000 °C / -454 ... 1832 °F	50 °C / 90 °F	± 0.35 °C / ± 0.63 °F	± 0.05 %
	Type R (Pt13Rh-Pt)	-50 ... 1768 °C / -58 ... 3215 °F	100 °C / 180 °F	± 0.95 °C / ± 1.71 °F	± 0.05 %
	Type S (Pt10Rh-Pt)	-50 ... 1768 °C / -58 ... 3215 °F	100 °C / 180 °F	± 0.95 °C / ± 1.71 °F	± 0.05 %
	Type B (Pt30Rh-Pt6Rh)	-0 ... 1820 °C / +32 ... 3308 °F	100 °C / 180 °F	± 0.95 °C / ± 1.71 °F	± 0.05 %
DIN 43710	Type L (Fe-CuNi)	-200 ... 900 °C / -328 ... 1652 °F	50 °C / 90 °F	± 0.35 °C / ± 0.63 °F	± 0.05 %
	Type U (Cu-CuNi)	-200 ... 600 °C / -328 ... 1112 °F	50 °C / 90 °F	± 0.35 °C / ± 0.63 °F	± 0.05 %
ASTM E 988	Type C	-0 ... 2315 °C / +32 ... 4200 °F	100 °C / 180 °F	± 1.35 °C / ± 2.43 °F	± 0.05 %
	Type D	-0 ... 2315 °C / +32 ... 4200 °F	100 °C / 180 °F	± 1.35 °C / ± 2.43 °F	± 0.05 %
	Voltage measurement	-125 mV ... 125 mV	2 mV	± 12 μV	± 0.05 %
	Voltage measurement	-125 mV ... 1100 mV	20 mV	± 120 μV	± 0.05 %

¹⁾ percentages refer to the configured measuring span

²⁾ standard model

³⁾ include the internal reference junction error for digital accuracy: Pt100, DIN IEC 60751 Cl. B

⁴⁾ without reference junction error

Total accuracy = digital accuracy [°C] + (D/A accuracy [%] x I conf. measuring span [°C] I / 100%)

(refer to the block diagram on next page)

Example 1:

Pt100 (IEC 60751), conf. measuring range 0 ... 100 °C, conf. measuring span = measurement end – measurement start = 100 °C

Digital accuracy: ± 0.08 °C

D/A accuracy ± 0.05% x (100 °C/100%) = ± 0.05 °C

Total accuracy: Digital accuracy + D/A accuracy; ± 0.08 °C + (± 0.05 °C) = ± 0.13 °C

Example 2:

Thermocouple type K, conf. measuring range 0 ... 1000 °C, conf. measuring span = measurement end – measurement start = 1000 °C

Digital accuracy: ± 0,35 °C

D/A accuracy ± 0.05% x (1000 °C/100%) = ± 0,50 °C

Total accuracy⁴⁾: Digital accuracy + D/A accuracy; ± 0,35 °C + (± 0,50 °C) = ± 0,85 °C

Long-term drift

± 0.05 °C or ± 0.05%¹⁾ per year, the larger value applies.

2.4.1 Block diagram

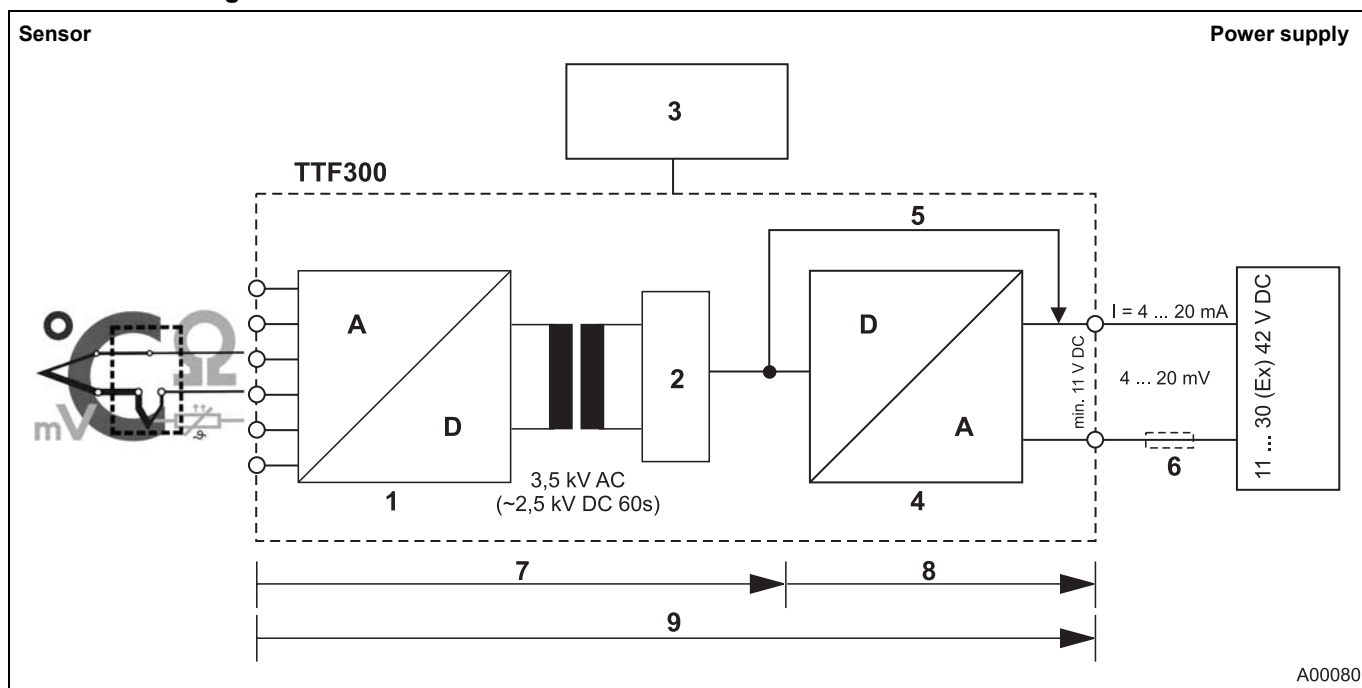

Fig. 2

- | | |
|--|--|
| 1 24-bit A/D converter | 6 Load (observe voltage drop, refer to the section "Terminal connection diagrams") |
| 2 Microcontroller | 7 Digital accuracy |
| 3 LC display with TTF300 configuration options | 8 D/A accuracy |
| 4 16-bit D/A converter | 9 Overall accuracy |
| 5 HART signal | |

2.5 Operating conditions

The percentages refer to the configured measuring span.

Supply voltage influence/load influence: within the specified limits for the voltage/load the total influence is less than 0.001% per volt

Common-mode interference no influence up to 100 V Veff (50 Hz) or 50 VDC

Ambient temperature influence: based on 23 °C / 73.4 °F (ambient temperature range: -40 ... 85 °C / -40 °F ... 185 °F)

Sensor	Ambient temperature influence For 1 °C / 1.8 °F dev. to 23 °C / 73,4 °F for digital readings	Ambient temperature influence ¹⁾ For 1 °C / 1.8 °F dev. to 23 °C / 73,4 °F for D/A converter
2-, 3-, 4-wire circuit		
RTD Pt10 IEC, JIS, MIL	± 0.04 °C / ± 0.072 °F	± 0.003 %
RTD Pt50 IEC, JIS, MIL	± 0.008 °C / ± 0.014 °F	± 0.003 %
RTD Pt100 IEC, JIS, MIL	± 0.004 °C / ± 0.007 °F	± 0.003 %
RTD Pt200 IEC, MIL	± 0.02 °C / ± 0.036 °F	± 0.003 %
RTD Pt1000 IEC, MIL	± 0.004 °C / ± 0.007 °F	± 0.003 %
RTD Ni50 DIN 43760	± 0.008 °C / ± 0.014 °F	± 0.003 %
RTD Ni100 DIN 43760	± 0.004 °C / ± 0.007 °F	± 0.003 %
RTD Ni120 DIN 43760	± 0.003 °C / ± 0.005 °F	± 0.003 %
RTD Ni1000 DIN 43760	± 0.004 °C / ± 0.007 °F	± 0.003 %
Resistance measurement 0 ... 500 Ω	± 0.002 Ω	± 0.003 %
Resistance measurement 0 ... 5000 Ω	± 0.02 Ω	± 0.003 %
Thermocouple for all defined types	± [(0.001% x (ME[mV] / MS[mV]) + (100% x (0.009 °C / MS [°C])) ¹⁾	± 0.003 %
Voltage measurement -125 ... 125 mV	± 1.5 μV	± 0.003 %
-125 ... 1100 mV	± 15 μV	± 0.003 %

¹⁾ percentages refer to the configured measuring span
ME - Measuring end, MS - Measuring span

Example 1

Pt100 configured measuring range 0 ... 100 °C, (measuring span 100 °C), ambient temperature 33 °C

Dev. from standard temperature: 33 ... 23 °C (reference) = 10 °C

Affect of ambient temperature on digital measurement: 10 °C x ± 0.004 °C / °C = ± 0.04 °C

Affect of ambient temperature on D/A converter: 10 °C x (± 0.003 % / °C) x (100 °C / 100 %) = ± 0.03 °C

Example 2

TC type K, conf. measuring range 0 ... 1000 °C, (measuring span 1000 °C), ambient temperature 33 °C

Measuring start 0 °C corresponds to 0.0 mV; measuring end = 1000 °C corresponds to 41.6 mV; measuring span = 1000 °C or 41.6 mV

Dev. from standard temperature: 33 ... 23 °C (reference) = 10 °C

Affect of ambient temperature on digital measurement: 10 °C x [(± 0.001% x 41.6 mV / 41.6 mV) + (100% x ± 0.009 °C / 1000°C)] x (1000°C / 100%) / °C = ± 0.19 °C

Affect of ambient temperature on D/A converter: 10 °C x [± 0.003 % x 1000 °C / 100 %] / °C = ± 0.3 °C

Worst case total error analysis

Max. possible total error = SQR [(digital accuracy)² + (D/A accuracy) + (digital value temp. influence) + (D/A temp. influence)]

Example 1: Pt100, 0 ... 100°C at 33 °C ambient temperature = $\sqrt{(0,08\text{ °C})^2 + (0,05\text{ °C})^2 + (0,04\text{ °C})^2 + (0,03\text{ °C})^2} = 0,10\text{ °C}$

Example 2: Thermocouple type K, 0 ... 1000 °C at 33 °C ambient temperature = $\sqrt{(0,35\text{ °C})^2 + (0,50\text{ °C})^2 + (0,19\text{ °C})^2 + (0,3\text{ °C})^2} = 0,70\text{ °C}$
(without reference junction error)

3 Mechanical design

Dimensions:	Refer to dimensioned drawings
Weight:	1.25 kg
Installation conditions:	<ul style="list-style-type: none">• Housing: Aluminum die cast, chromized inside/outside, 70 µm epoxide-coated (aluminum with 12 % silicon, magnesium content < 0.3 %, copper-free < 0.05 %)• Color: gray RAL9002• Types of protection: IP66 and IP67; NEMA 4X, ENCL 4X• Installation position: No limitations
Electrical connection:	<ul style="list-style-type: none">• Thread (selectable) 2 x M20 x 1.5 / 2 x ½" NPT / 2 x ¾" NPT (via reducing piece)• with cable fitting 2 x M20 1.5:<ul style="list-style-type: none">Polyamide/gray: Non ignition-proof design, nonincendive max. cable outer diameter 5 ... 9 mm, temp. range acc. to data for cable fittings (manufactured by Hummel, model 1.209.2000.51)Polyamide/blue: EEx ia design, intrinsically safe max. cable outer diameter 5 ... 9 mm, temp. range acc. to data for cable fittings (manufactured by Lapp, model 5401 7600)

Metal cable fitting:

dust-ignition proof, hermetically sealed, explosion-proof
max. cable outer diameter
6 ... 7.5 mm, temp. range -
20 ... 90 °C / -4 ... 194 °F

- Ground screw external 6 mm² M5
internal 2 x 2.5 mm² M4
- Terminals for lines up to 2.5 mm² and hand-held terminal interface

Lightning protection:

- **model NGV220-NO**
Non ignition-proof lightning protection for M20 x 1.5 cable fitting (see data sheet 10/63-6.15)
- **model NGV220-Ex**
Intrinsically safe lightning protection for M20 x 1.5 cable fitting (see data sheet 10/63-6.15)

4 Communication

HART protocol version 5

The system is registered with the HART Communication Foundation.

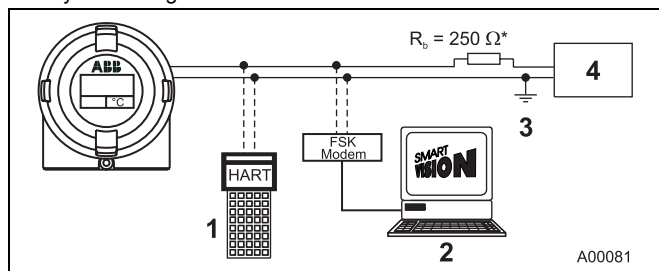

Fig. 3

* if necessary

- | | |
|--|---------------------------------------|
| 1 DHH691 (691HT), STT04,
HC275, FC375 | 3 Ground connection
(optional) |
| 2 FDT/DTM technology | 4 Power supply (process
interface) |

Operating modes

- Point-to-point communication mode: standard (general address 0)
- Multidrop mode (addressing 1 ... 15)
- Burst mode

Configuration options and tools

Driver-independent:

- HMI indicator type A with configuration function

Driver-dependent:

- Device management/asset management tools
- FDT/DTM technology
- DSV401 (SMART VISION) via TTX300-DTM driver

Configuration parameters

Measurement type

- Sensor type, connection type
- Fault signaling
- Measuring range
- General information, e.g., TAG number
- Attenuation
- Warning and alarm limits
- Signal simulation of output
- See "Order form configuration"

Write protection

- Software write protection via HART/indicator
- Hardware write protection via jumper

Diagnostic information (in accordance with NE107)

Standard

- Sensor error (wire break or short circuit)
- Device error
- Over/under alarm limits
- Over/under measuring range
- Simulation activated

Extended mode

- Redundancy/sensor backup activated (in case sensor fails)
- Sensor corrosion
- Supply voltage undershoot
- Drag indicator for sensor 1 and sensor 2
- Ambient temperature overshoot (> 85 °C)

5 Explosion-protection relevant information

5.1 TTF300-E1... (intrinsically safe)

Approved for use in zone 0.

Designation:

- II 1G EEx ia IIC T6 (Zone 0)
- II 2 (1) G EEx [ia] ib IIC T6 (zone 1 [0])
- II 2 G (1D) Ex [iaD] ib IIC T6 (zone 1 [20])



Note

The Ex or ignition-proof designation is provided on the model plate.

EC prototype test certificate: Refer to PTB 05 ATEX2017 X.

Temperature table

Temperature class	Permissible ambient temperature range	
	Device category 1 use	Device category 2 use
T6	-50 ... 44 °C	-50 ... 56 °C
T5	-50 ... 56 °C	-50 ... 71 °C
T4	-50 ... 84 °C	-50 ... 85 °C

Safety-relevant data

Intrinsically safe EEx ia IIC explosion protection

	Supply circuit	Measurement current circuit / passive transducer (RTD)	Measurement current circuit / active transducer (RTD)	Display interface
Max. voltage	$U_i = 30 \text{ V}$	$U_o = 6.5 \text{ V}$	$U_o = 1.2 \text{ V}$	$U_o = 6.2 \text{ V}$
Short-circuit current	$I_i = 130 \text{ mA}$	$I_o = 25 \text{ mA}$	$I_o = 50 \text{ mA}$	$I_o = 65.2 \text{ mA}$
Max. power	$P_i = 0.8 \text{ W}$	$P_o = 38 \text{ mW}$	$P_o = 60 \text{ mW}$	$P_o = 101 \text{ mW}$
Internal inductance	$L_i = 490 \text{ }\mu\text{H}$	$L_i = 0 \text{ mH}$	$L_i = 0 \text{ mH}$	$L_i = 0 \text{ mH}$
Internal capacitance	$C_i = 3.63 \text{ nF}$	$C_i = 49 \text{ nF}$	$C_i = 49 \text{ nF}$	$C_i = 0 \text{ nF}$
Maximum permissible external inductance		$L_o = 5 \text{ mH}$	$L_o = 5 \text{ mH}$	$L_o = 5 \text{ mH}$
Maximum permissible external capacitance		$C_o = 1.55 \text{ }\mu\text{F}$	$C_o = 1.05 \text{ }\mu\text{F}$	$C_o = 1.4 \text{ }\mu\text{F}$

5.2 TTF300-E2... (nonincendive)

Approved for use in zone 2/22.

Designation:

- II 3 G EEx n A II T6
- II 3 D IP 65 T 135 °C



Note

The Ex or ignition-proof designation is provided on the model plate.

ABB statement of conformity in accordance with ATEX directive.

Temperature table

Temperature class	Permissible ambient temperature range
T6	-50 °C ... 56°C
T5	-50 C ... 71°C
T4	-50 C ... 85 C

CSA and FM

Intrinsically safe (in preparation)

FM	Class I, Div. 1 + 2, Groups A, B, C, D T6 Class II, Groups E, F, G; Class III Class I, Zone 0, AEx ia IIC T6 Control drawing: TTF300-L1
CSA	Class I, Div. 1 + 2, Groups A, B, C, D Class II, Groups E, F, G; Class III Control drawing: TTF300-R1

Nonincendive (in preparation)

FM	Class I, Div. 2, Groups A, B, C, D (Class II, Groups E, F, G; Class III Control drawing: TTF300-L2
CSA	Class I, Div. 2, Groups A,B,C,D (Class II, Groups E, F, G; Class III Control drawing: TTF300-R2

Dust-explosion protection:

TTF300-D1..... Dust-explosion protection

Dust / Zone 20:

Designation: "Ex mark" II 1 D IP 65 T 135°C

EC prototype test certificate BVS 06 ATEX E 029

TTF300-D2..... Dust-explosion protection + Intrinsic safety

Dust / Zone 20 + Gas / Zone 0:

Designation: "Ex mark" II 1 D IP 65 135°C

"Ex mark" II 1G EEx ia IIC T6

EC prototype test certificate BVS 06 ATEX E 029

EC prototype test certificate PTB 05 ATEX 2017 X

Hermetically sealed

TTF300-E3....hermetically sealed

Zone 1:

Designation: "Ex mark" II 2G EEx d IIC T6

EC prototype test certificate PTB 99 ATEX 1144

TTF300-E4....hermetically sealed + intrinsic safety

Zone 1:

Designation: "Ex mark" II 2G EEx d IIC T6

"Ex mark" II 1G EEx ia IIC T6

EC prototype test certificate PTB 99 ATEX 1144

EC prototype test certificate PTB 05 ATEX 2017 X

Explosion-proof

TTF300-L3..... FM explosion-proof

XP,NI, DIP Class I, II, III, Div. 1 + 2, Groups A-G, factory sealed

Control drawing: TTF300-L3

TTF300-R4..... CSA explosion-proof

XP,NI, DIP Class I, II, III, Div. 1 + 2, Groups A-G, factory sealed

Control drawing: TTF300-R3

6 Approvals

6.1 TTF300

CE mark

The TTF300 meets all requirements for the CE mark in accordance with IEC 61326 (2002).

Namur

The TTF300 complies with NAMUR NE 21 (02/2004).

Ignition protection

The TTF300 meets requirements for ATEX, FM and CSA. For additional information, refer to the section "Explosion-protection relevant information").

SIL: Functional safety (optional)

In preparation in accordance with IEC 61508.

Device with certificate of conformity for use in safety-relevant applications, including SIL 2 type.

7 LC display

Dual function: LC display with TTF300 configuration options

7.1 Features of LC display

- Transmitter-controlled graphic (alphanumeric) LC display
- Character height, mode-dependent
- Sign, 4 digits, 2 decimal places
- Bar graph display
- Rotatable in 30° increments
- Display options:
 - Sensor 1 process data
 - Sensor 2 process data
 - Sensor 1 electrical (Ω / mV)
 - Sensor 2 electrical (Ω / mV)
 - Electronics/ambient temperature
 - Output/current
 - Output %
- Display diagnostic information related to transmitter and sensor status

7.1.1 Technical data of LC display

Temperature range:	-20 ... 70 °C (-50 ... -20 °C or 70 ... 85 °C no function)
Humidity:	0 ... 100 %, condensation permitted
Dimensions:	see the section Dimensioned drawings

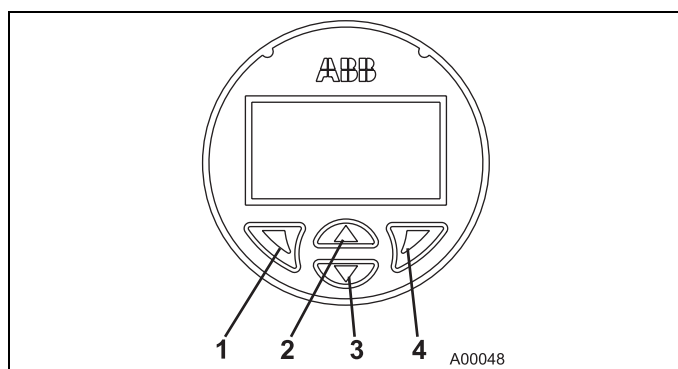

Fig. 4

- | | |
|---------------|------------------|
| 1 Exit/Cancel | 3 Scroll forward |
| 2 Scroll back | 4 Select |

7.2 Configuration function of LC display

- Configurable TTF300 transmitter parameters per display: All parameters (sensor/type circuit, measuring range, error current signal, etc.) except: table-based sensor and freestyle characteristics, Callendar van Dusen coefficients, warning and alarm limits
- Hardware and software write protection for TTF300 configuration

7.3 LC display HMI ignition-proof type A (intrinsically safe)

Approved for use in zone 0.

Designation:

- II 1G EEx ia IIC T6



Note

The Ex or ignition-proof designation is provided on the model plate.

EC prototype test certificate: PTB 05 ATEX 2079 X

Temperature table

Temperature class	Permissible ambient temperature range	
	Device category 1 use	Device category 2 use
T6	-40 ... 44 °C	-40 ... 56 °C
T5	-40 ... 56 °C	-40 ... 71 °C
T4	-40 ... 60 °C	-40 ... 85 °C

For the ambient temperature range from -50 °C to -20 °C, additional mechanical protection is required.

Safety-relevant data

Intrinsically safe EEx ia IIC explosion protection

	Supply circuit
Max. voltage	$U_i = 9 \text{ V}$
Short-circuit current	$I_i = 65.2 \text{ mA}$
Max. power	$P_i = 101 \text{ W}$
Internal inductance	$L_i = 0 \text{ mH}$
Internal capacitance	$C_i = 0 \text{ nF}$

8 Terminal connection diagrams

RTD resistance sensors

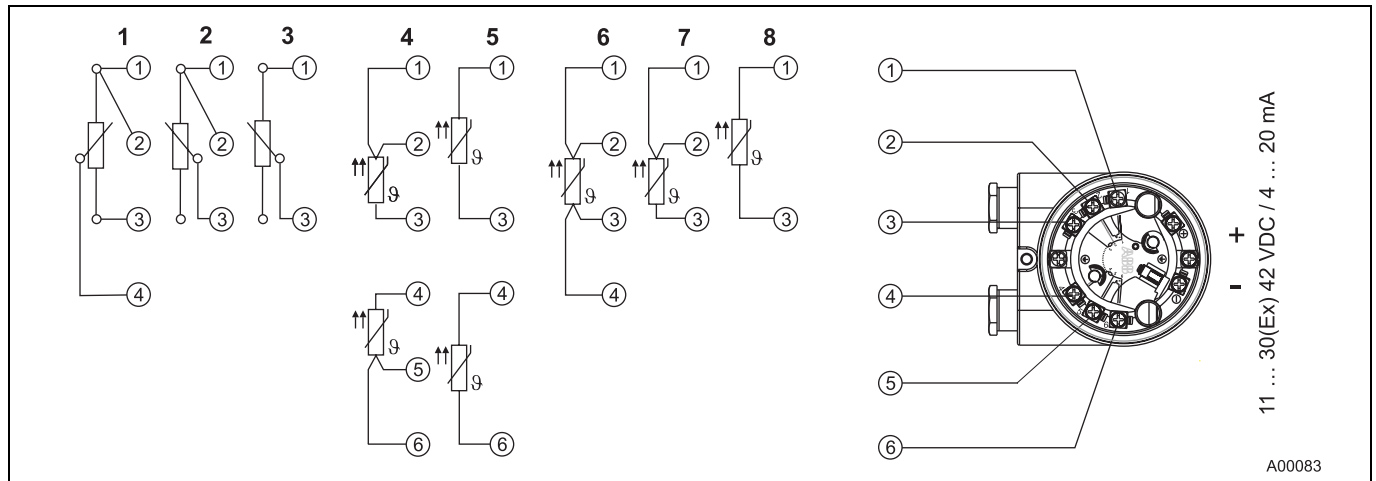

Fig. 5

Potentiometer: 0 ... 500 Ω or 0 ... 5000 Ω

- 1 Potentiometer, 4-wire circuit
- 2 Potentiometer, 3-wire circuit
- 3 Potentiometer, 2-wire circuit

- 4 2 x RTD, 3-wire circuit (sensor backup/redundancy, average value or differential temperature measurement)
- 5 2 x RTD, 2-wire circuit (sensor backup/redundancy, average value or differential temperature measurement)

- 6 RTD, 4-wire circuit
- 7 RTD, 3-wire circuit
- 8 RTD, 2-wire circuit

Thermocouples/Voltages

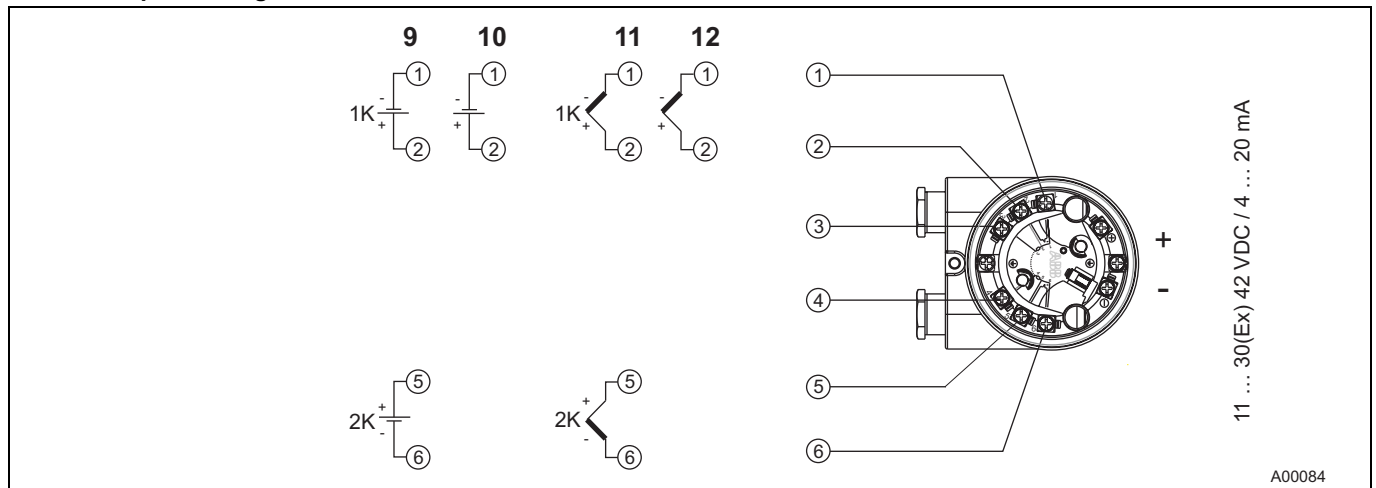

Fig. 6

- 9 2 x voltage measurement (sensor backup/redundancy, average value or differential temperature measurement)
- 10 Voltage measurement

- 11 2 x thermocouple (sensor backup/redundancy, average value or differential temperature measurement)
- 12 Thermocouple

RTD/thermocouples configuration

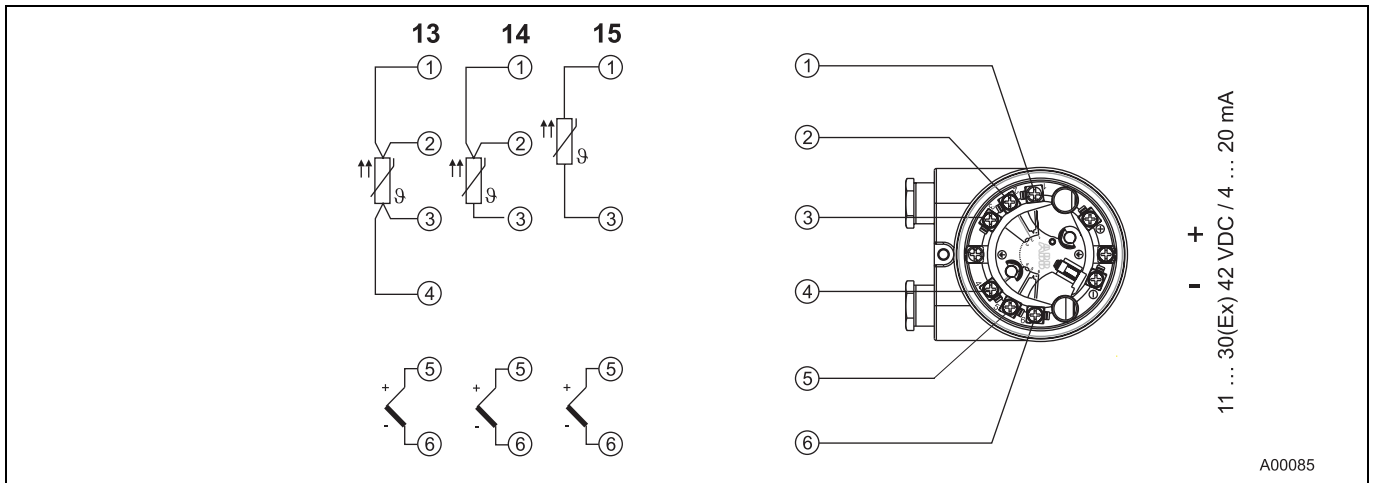

Fig. 7

- 13 1 x RTD, 4-wire circuit and thermocouple
- 14 1 x RTD, 3-wire circuit and thermocouple
- 15 1 x RTD, 2-wire circuit and thermocouple

9 Dimensioned drawing

9.1 TTF300

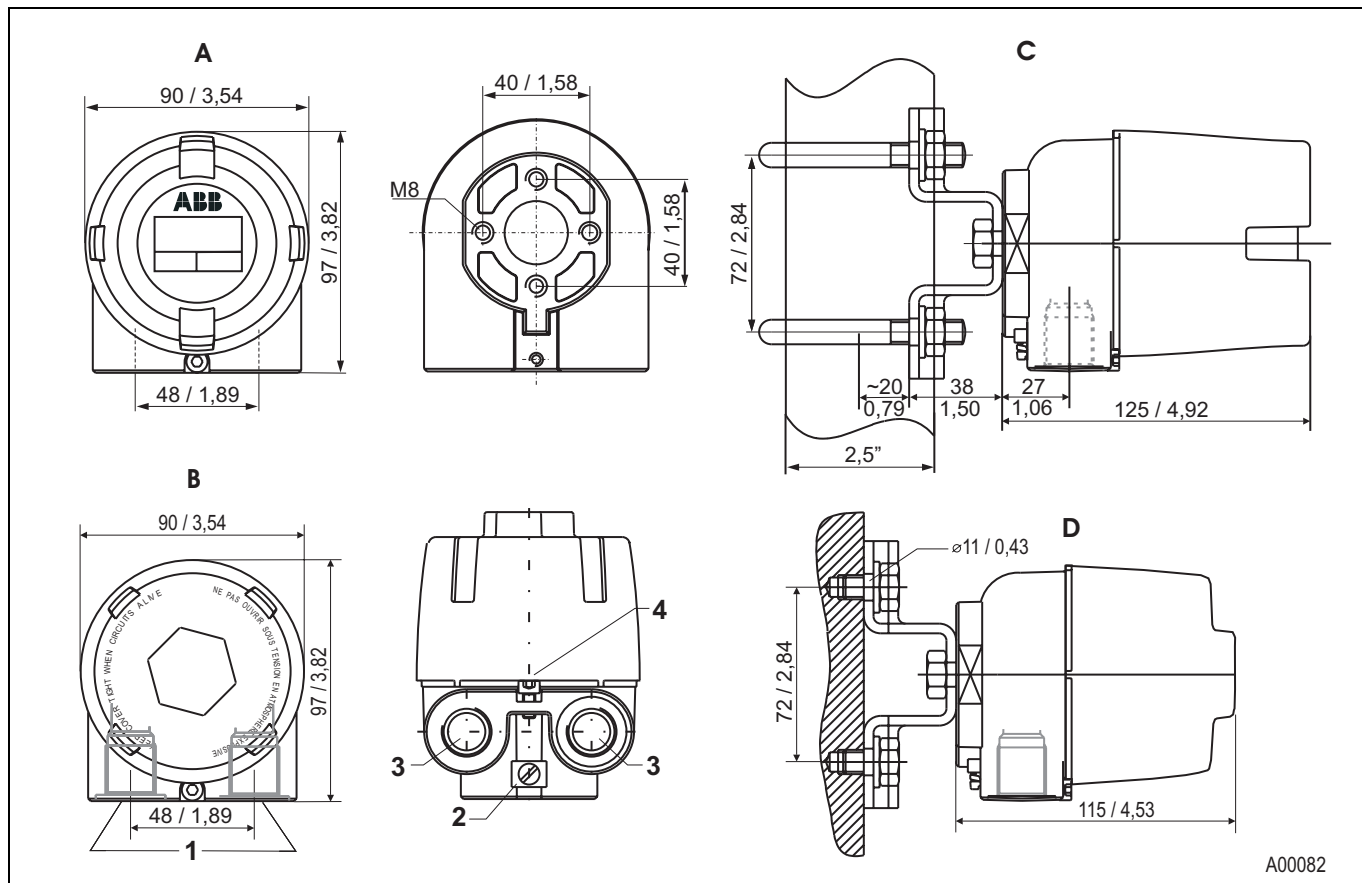

Fig. 8: Housing and mounting type with dimensions in mm/inches

- | | | | |
|---|---|---|--------------------------------|
| A | AGLFD housing | 1 | Electrical connections |
| B | AGLF housing | 2 | Equipotential bonding screw M5 |
| C | Tube mount | 3 | Thread M20 x 1.5 ½ NPT |
| D | Wall mount, 4-hole wall attachment, Ø 11 mm / 0.43 inch, quadratically arranged, at distance of 72 mm / 2.84 inches | 4 | Lock screw |

10 Ordering information

Field mounted Temperature Transmitter		Variant digit No.	1 - 7	8	9	10	11	Code			
TTF300 Standard configuration: Pt 100, 3 wire circuit, 1 channel, 0...100 °C, overranging 22 mA, damping off		Catalog No.	TTF300-								
Explosion Protection											
TTF300	without explosion protection			Y	0						
Type of protection: intrinsically safe ATEX											
TTF300	ATEX Zone 0: II 1 G EEx ia IIC T6			E	1						
	Zone 1 (0): II 2 (1) G EEx [ia] ib IIC T6										
	Zone 1 (20): II 2 G (1D) Ex [iaD] ib IIC T6										
Type of protection: non sparking "nA" ATEX											
TTF300	ATEX Zone 2 / Zone 22: II 3 G EEx nA II T6 and II 3 D IP 65 T135°C			E	2						
Type of protection: intrinsically safe FM & CSA											
TTF300	FM IS, Class I, Div. 1+2, Groups A, B, C, D, Class II, E, F, G, Class III Class I, Zone 0, AEx ia IIC T6			L	1						
	FM nonincendive, Class I, Div. 2, Groups A, B, C, D, Class II, E, F, G, Class III			L	2						
TTF300	CSA IS, Class I, Div. 1+2, Groups A, B, C, D, Class II, E, F, G, Class III			R	1						
	CSA nonincendive, Class I, Div. 2, Groups A, B, C, D, Class II, E, F, G, Class III			R	2						
Type of protection: Dust explosion proof											
TTF300	ATEX Zone 20: II 1 D IP 65 T135°C			D	1						
TTF300	ATEX Zone 0 / Zone 20: II 1 G EEx ia IIC T6 and II 1 D IP 65 T135°C			D	2						
Type of protection: Flameproof											
TTF300	ATEX Zone 1: II 2 G EEx d IIC T6			E	3						
TTF300	ATEX Zone 1 / Zone 0: II 2 G EEx d IIC T6 and II 1 G EEx ia IIC T6			E	4						
Type of protection: Explosion Proof											
TTF300	FM XP, NI, DIP, Class I, II, III, Div. 1+2, Groups A-G, factory sealed			L	3						
TTF300	CSA XP, NI, DIP, Class I, II, III, Div. 1+2, Groups A-G, factory sealed			R	3						
Housing / Display											
Single-compartment housing (AGLF) / without display (Aluminium)				A							
Single-compartment housing (AGSF) / without display (Stainless steel)				B							
Single-compartment housing (AGLFD) / with LCD-display HMI type A (Aluminium)				C							
Single-compartment housing (AGSFD) / with LCD-display HMI type A (Stainless steel)				D							
Cable entry											
Thread 2 x M20 x 1.5							1				
Thread 2 x 1/2" NPT							2				
Thread 2 x 3/4" NPT (via 1/2" > 3/4" adapter)							3				
Cable screw connection 2 x M20 x 1.5							4				

Additional order information

TTF300	Code			
Configuration				
Customer specific configuration with report, except user curve (e.g. set measuring range, TAG-no.)	BF			
Customer specific configuration with report, including user curve	BG			
Certificates				
SIL2 - Declaration of conformity	CS			
Calibration Certificate				
with 2-point works calibration certificate	EK			
with 5-point works calibration certificate	EM			
with extended works calibration certificate (9-point)	EN			
Mounting bracket				
wall mounting / 2" pipe mounting bracket (Stainless steel)	K2			
Extended Ambient Temperature range				
-50...+85 °C	SE			
Name plate				
Stainless steel plate with TAG no.	T1			
Customer specific model acc. to NL no. (please specify)	Z9			

Accessories				
		Catalog No.		
NGV220-NO	Surge / Lightning protection for M20 x 1.5 cable glands, non-Ex version	see data sheet 10/63-6.15 EN		
NGV220-EX	Surge / Lightning protection for M20 x 1.5 cable glands, Ex version	see data sheet 10/63-6.15 EN		

11 Order form configuration

Information on customer-specific configuration of temperature transmitter TTF300.

Configuration		Selection
Number of sensors		<input type="checkbox"/> 1 sensor <input type="checkbox"/> 2 sensors
Measurement type (for 2-sensor selection only)		<input type="checkbox"/> Redundancy and sensor backup <input type="checkbox"/> Differential measurement: Zero point where $I_a = 4 \text{ mA}$ <input type="checkbox"/> Differential measurement: Zero point where $I_a = 12 \text{ mA}$ <input type="checkbox"/> Mean
DIN IEC 60 751	RTD	<input type="checkbox"/> Pt10 <input type="checkbox"/> Pt50 <input type="checkbox"/> Pt100 (standard)
JIS C1604-81		<input type="checkbox"/> Pt200 <input type="checkbox"/> Pt500 <input type="checkbox"/> Pt1000
MIL-T-24388		<input type="checkbox"/> Pt10 <input type="checkbox"/> Pt50 <input type="checkbox"/> Pt100 <input type="checkbox"/> Pt200 <input type="checkbox"/> Pt1000
DIN 43760		<input type="checkbox"/> Ni50 <input type="checkbox"/> Ni100 <input type="checkbox"/> Ni120 <input type="checkbox"/> Ni1000
Cu		<input type="checkbox"/> Cu10 <input type="checkbox"/> Cu100
	Linear Resistance measurement	<input type="checkbox"/> 0 ... 500 Ω <input type="checkbox"/> 0 ... 5000 Ω
IEC 584	Thermocouple	<input type="checkbox"/> Type K <input type="checkbox"/> Type J <input type="checkbox"/> Type N <input type="checkbox"/> Type R <input type="checkbox"/> Type S <input type="checkbox"/> Type T
DIN 43710		<input type="checkbox"/> Type E <input type="checkbox"/> Type B
ASTME 988		<input type="checkbox"/> Type L <input type="checkbox"/> Type U <input type="checkbox"/> Type C <input type="checkbox"/> Type D
	Linear voltage measurement	<input type="checkbox"/> -125 mV ... 125 mV <input type="checkbox"/> -125 mV ... 1100 mV
Sensor circuit (for RTD + resistance measurement only)		<input type="checkbox"/> 2-wire <input type="checkbox"/> 3-wire (standard) <input type="checkbox"/> 4-wire 2-wire circuit: Compensation of sensor-wire resistance max. 100 Ω <input type="checkbox"/> Sensor 1: Ω <input type="checkbox"/> Sensor 1: Ω
Reference junction (for thermocouples only)		<input type="checkbox"/> Internal (for standard thermocouples except type B) <input type="checkbox"/> none (TE type B) <input type="checkbox"/> External/temp.:..... $^{\circ}\text{C}$
Measuring range		<input type="checkbox"/> Measurement start: (standard: 0) <input type="checkbox"/> Measurement end: (standard: 100)
Unit		<input type="checkbox"/> Celsius (standard) <input type="checkbox"/> Fahrenheit <input type="checkbox"/> Rankine <input type="checkbox"/> Kelvin
Output behavior for error		<input type="checkbox"/> Override/22 mA (standard) <input type="checkbox"/> Underdrive/3.6 mA
Output attenuation (T_{63})		<input type="checkbox"/> Off (standard) <input type="checkbox"/> Seconds (1 sec. ... 100 sec.)
Sensor number		<input type="checkbox"/> Sensor 1..... <input type="checkbox"/> Sensor 2.....
Resistor value at 0°C / R_o Callendar van Dusen coefficient A Callendar van Dusen coefficient B Callendar van Dusen coefficient C (optional for RTD/Pt sensors only)		Sensor 1: R_o : Sensor 2: R_o : A: A: B: B: C: C:
User characteristics based on linearization table		<input type="checkbox"/> based on attached table of variate pairs
TAG number		<input type="checkbox"/> (max. 8 characters)

ABB provides expert and comprehensive consulting services
in more than 100 countries worldwide.

www.abb.com

ABB is continually improving its products. As a
result, technical information in this document is
subject to change.

Printed in the Fed. Rep. of Germany (04.2006)

© ABB 2006

3KXT221001R1001



ABB Limited

Salterbeck Trading Estate
Workington, Cumbria
CA14 5DS
UK
Tel: +44 (0)1946 830 611
Fax: +44 (0)1946 832 661

ABB Inc.

125 E. County Line Road
Warminster, PA 18974
USA
Tel: +1 215 674 6000
Fax: +1 215 674 7183

ABB Automation Products GmbH

Borsigstr. 2
63755 Alzenau
Germany
Tel: +49 551 905-534
Fax: +49 551 905-555
CCC-support.deapr@de.abb.com