

- **Excellent accuracy over wide operating flow range in both forward and reverse flow directions**
 - enables accurate measurement of peak daytime flows and minimal night flows
- **Battery Operation**
 - 2½ year life
 - no external power supply required
 - facilitates installation in remote location
- **AC powered with optional battery backup**
 - continuous measurement even during power-down
- **Optional built-in multi-speed, multi-channel, dual-variable logger**
 - high precision, high resolution datalogging
- **'Hot tap' capability**
 - enables installation with no interruption to normal water supply
- **Pressure sensor input**
 - enables monitoring and logging of line pressure
- **'Fit and Flow™'**
 - simplifies installation



AquaProbe
– the economic alternative to
full-bore flow metering

AquaProbe 2

AquaProbe 2 extends the capability of the ABB AquaProbe flow meter by bringing together the proven AquaProbe probe with the innovative AquaMaster Electronic Display Unit.

AquaProbe has been designed, in close consultation with the water industry, as an economic and accurate alternative to full bore metering. It comprises an electromagnetic sensing head mounted on the end of a support rod. This assembly can be installed in existing pipelines without the need for the major excavations or alterations to pipework associated with full bore meters. It can be fitted without interrupting the water supply and can be removed easily for periodic calibration or inspection.

Key features include the wide flow range with the minimum measured velocity well below that detected by insertion turbine or DP devices, no moving parts resulting in increased reliability and reduced maintenance.

AquaProbe is ideal for permanent installation to monitor potable or clean water flow. Also through the provision of multiple tappings on the supply pipelines, AquaProbe can be used as a portable survey tool to assist in the building of an accurate network model, locate leaks and check the operation of installed full bore meters.

The high sensitivity of AquaProbe enables it to traverse the pipe to establish the flow profile and so identify hydraulic problems in complex systems or ensure maximum accuracy from an AquaProbe, which has been installed in a non-ideal location.



No External Power Required for Remote Locations

- No external power supply (two internal batteries)
- 3-year battery life
- Site-replaceable batteries
- Unique battery management system gives a battery replacement window in excess of 1 year, with no flat battery interruption to measurement

AquaProbe 2 is the ideal solution for locations where there is no external power. Two user-replaceable internal batteries provide a 2½-year battery life, thus eliminating the high cost of providing a mains supply to the meter. AquaProbe II's extended battery life is achieved through new technology design.

AC-powered units have optional battery backup to ensure no loss of flow measurement during power-down periods.

Based on ABB proven technology, AquaProbe 2 is supported by the expertise of ABB, the world's leading flow meter manufacturer with many pioneering advances in water flow metering over the last decade. For example, AquaMag™, MagMaster™, AquaProbe™, CalMaster™ etc. ABB operate nationally, and internationally, accredited flow calibration facilities in the UK, Germany, USA, Australia and India. We also offer comprehensive, locally based before- and after-sales service.

Logger Facility

The AquaProbe 2 display unit is available with a multichannel, multivariable logger. The ability of the logger to run at two speeds simultaneously enables the user to investigate, in precise detail, the flow and pressure activity during a period of interest. The logger logs both flow and pressure via a direct digital transfer of data, thereby ensuring optimum accuracy and resolution of measurement. Fig. 1 (below) illustrates actual district network measurements showing extra detail captured utilizing the twin loggers. Traditional techniques of counting pulses over a short logging interval leads to ‘quantization’ effects corresponding to whole numbers of pulses on logger graphs which is shown on Fig. 2 (below). AquaProbe 2 eliminates such effects, averaging digitally over the selected logging interval. Such high resolution data facilitates step testing, leak detection and water network analysis.

The AquaProbe 2 internal loggers feature an advanced automatic time synchronization function that ensures operation on synchronized time boundaries no matter what logging interval is set. This ensures all flow and pressure data, when combined with data from other meters, is precisely synchronized facilitating precise network balance.

For revenue applications, not only is the flow and pressure logged information available, a totalizer and tariff logger is also available to log all volume totals (forward, reverse, net) and tariff readings totals every midnight. Its memory of 366 days keeps all records for one year. The readings stored are the precise register volumes and are not inferred by integration of pulses or other similar techniques.

Access to the loggers and modifying the configuration of logger setup is security-protected by user passwords, which can be changed by the user.

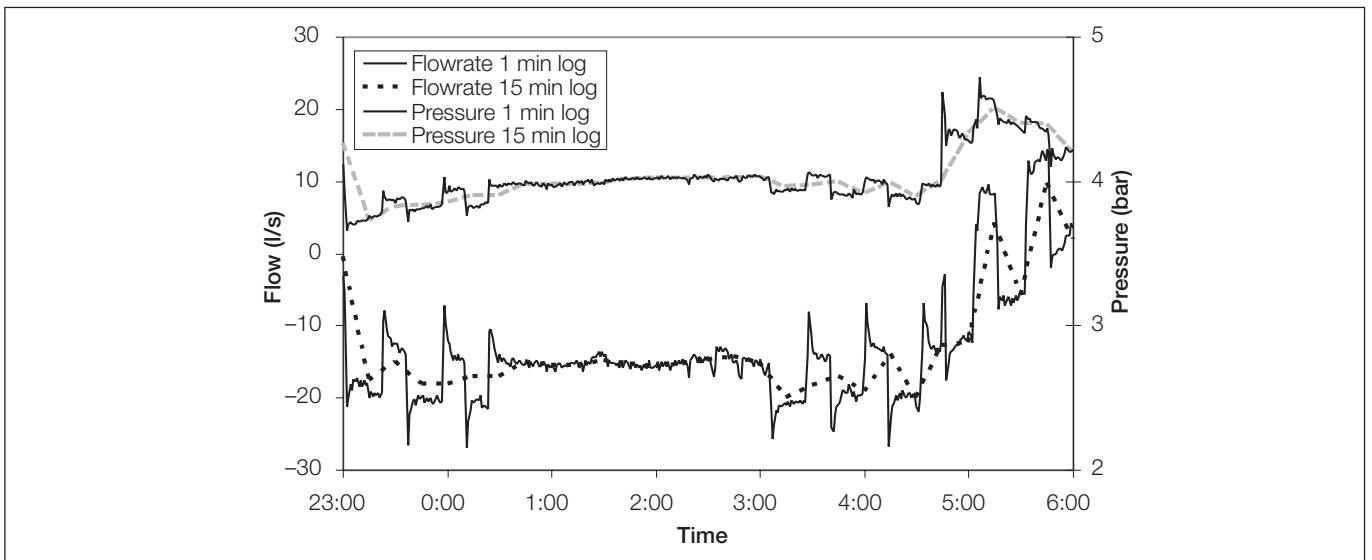

Fig. 1 Actual District Network Measurements

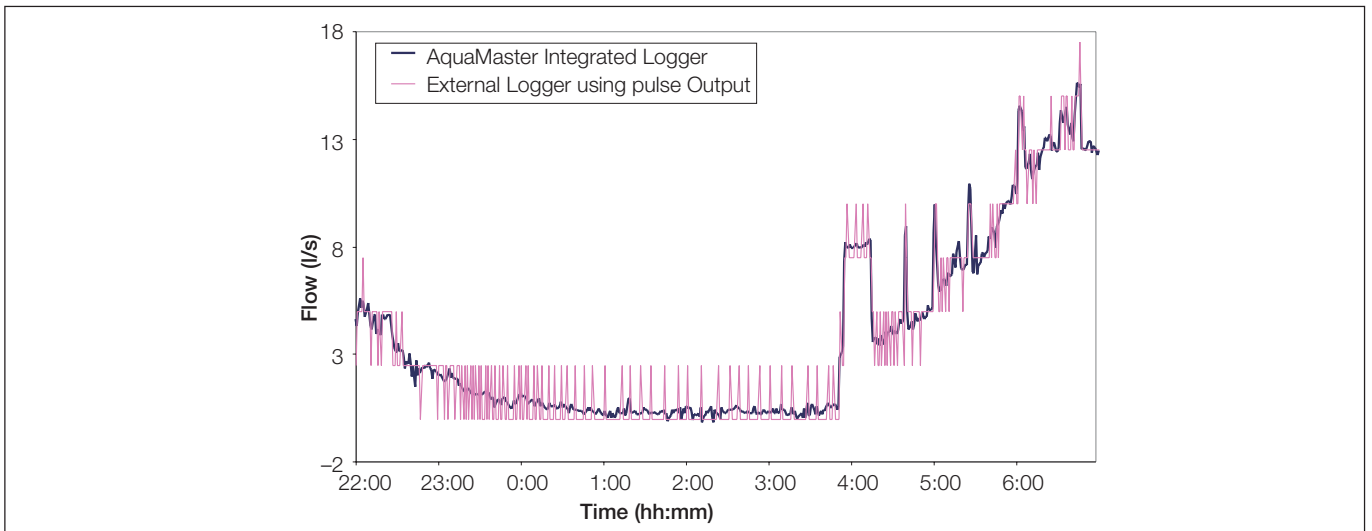

Fig. 2 Whole Numbers of Pulses

Support Software

AquaMaster S is available with a variety of industry standard third party software, (Technolog™ [PMAC], Primayer™ [Primeware], OSI™ PI database and IBV™ [WADIS]) for download, management, analysis and display of data, either directly from the RS232 port or via telemetry. Separate data sheets are available describing these systems.

ABB also supply LogMaster, a simple-to-use PC software program, that provides local communication to the AquaProbe 2 and enables full control and downloading of the onboard datalogger. A file-save facility enables data to be exported in CSV format for charting in Microsoft Excel™ or similar spreadsheets. It supports Vodafone Radiopad™ remote connection, with an address book, for full remote operation. LogMaster is Windows 98™ Windows & NT™ compatible and is available in a variety of different languages.

AquaProbe 2 also has on-board remote communication ability such as interfacing to an external Vodafone VVADS radiopad, with internal GSM as a future option and, of course, RS232, which enables the user to collect data remotely and service the unit without leaving the office.



Electronic Display Unit

The AquaProbe 2 Electronic Display Unit provides a comprehensive display of all flow data, including forward and reverse flow totals, flow rate, pressure, time/date etc. If all the data is not required, the transmitter is configured easily to only display the required values, ensuring simple reading with no superfluous data. The two standard pulse outputs (forward and reverse flow direction) are compatible with the wide range of dataloggers used in the water industry, worldwide.

The Electronic Display Unit is fully submersible, enabling it to be mounted locally in chambers, that are liable to flooding or alternatively, up to 200m (650 ft) remote from the probe to facilitate ease of reading.

- Comprehensive display
- Submersible for use in flooded chambers IP68 (NEMA6P)
- IP65 (NEMA4X) Plastic version for roadside cabinets or panel mounting
- Resettable or secure totals
- 5mm high displays for totals (exceeds ISO 4064 requirements)
- Total security
Two user-security levels
Anti-tamper switch and seals
- Three outputs
(forward & reverse pulse, pulses & direction and alarm)

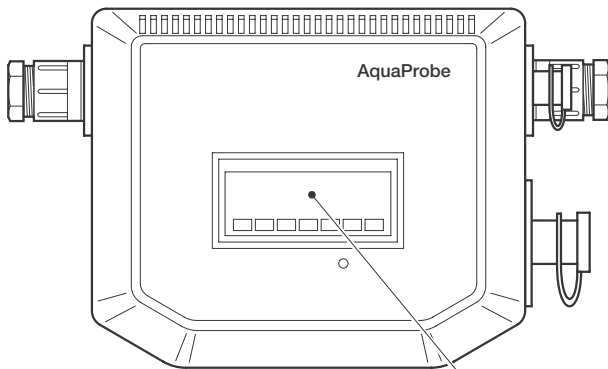

The AquaProbe II's program memory or firmware uses re-programmable Flash memory technology, that has been enhanced to enable this firmware to be upgraded in the field, via a local serial port connection or a radio link, if fitted. This future proofs AquaProbe, making enhancements or new features available to installed units. Two versions of enclosure are available: an IP68 (NEMA6P) rated metal version designed for remote mounting where possible submersion can occur, or an IP65 (NEMA4X) plastic version, which is best suited to roadside furniture or panel mounting.

9-Digit LCD Display

- Cyclic display*
- 5mm High
 - Forward total
 - Reverse total
 - Net total
 - Date

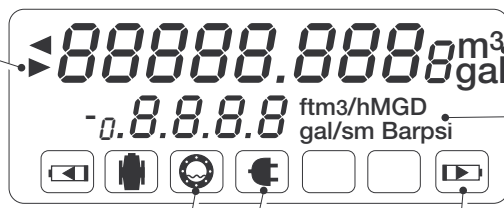

Choice of Units

To match user requirements

5-Digit LCD Display

- Cyclic display*
- Flow rate
 - Pressure (optional)
 - Time
 - Velocity

Loss of power

Status Indicators

- Battery A low
- Battery B low
- Fault

Empty pipe

* Can be programmed to display required values only

Easy, Low Cost Installation

No matter what the location or installation requirements, AquaProbe 2 provides a cost-effective solution.

Both the probe and the Electronic Display Unit can be fully submersible, enabling installation in flooded chambers.

The AquaProbe is installed by means of a small valve tapping on the water supply pipeline normally with the sensing head on the pipe centerline. It may be located at the critical position (the mean velocity position) a distance of $\frac{1}{8}$ of the diameter away from the wall.

AquaProbe 2 provides an accurate local measurement of the water velocity and, provided the installation instructions have been carefully followed a good flow volume measurement.

'Fit and Flow'

- No need to match probe and Electronic Display Unit
- Fast, reliable installation
- Foolproof; no errors
- Probe stores all calibration factors, site settings, serial numbers, totalizer values etc.
- Totalizer volume values backed up in probe for total security

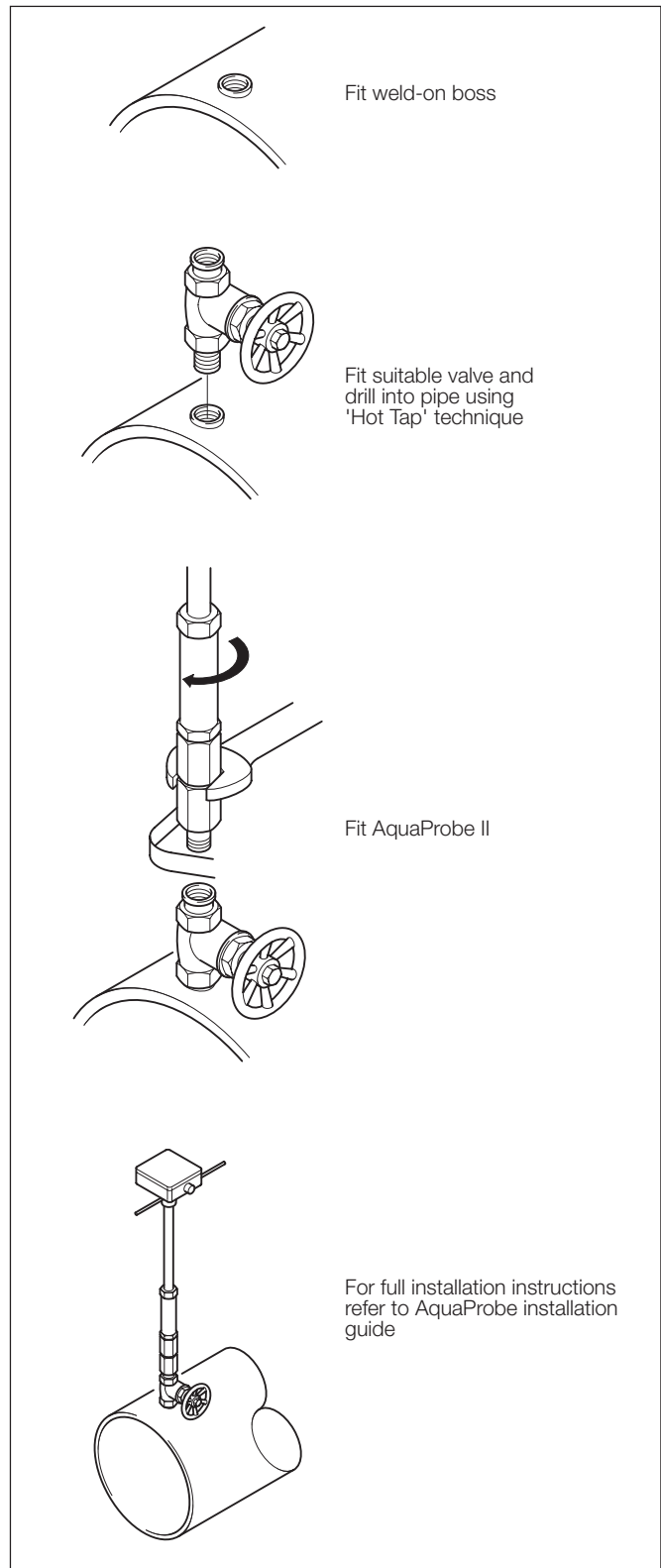

Typical Installation (Metal Pipe)

Specification

Probe

Maximum insertion length

- 300mm (12 in.)
- 500mm (20 in.)
- 700mm (25 in.)
- 1000mm (40 in.)

Pipe sizes

200mm to 8000mm (8 in. to 320 in.) nominal bore

Protection

IP68/NEMA6 (Indefinite submersion down to 10m [30 ft])

Weight

<3.5kg (7.7 lb)

Accuracy

Velocity

±2% of Rate or ±2mm/s (±0.08 in./s) whichever is the greater

Volume

Refer to ISO 7145-1982 (BS 1042 section 2.2) for details

Flow condition

Fully developed profile in accordance with ISO 7145-1982 (BS1042 section 2.2.)

Pressure limitations

20bar (295 psi)

Pressure equipment Directive 97/23/EC

This product is applicable in networks for the supply, distribution and discharge of water and associated equipment and is therefore exempt

Conductivity

>50µS/cm

Connections

- 1 in. BSP
- 1 in. NPT
- 1.5 in. BSP

Temperature Ranges

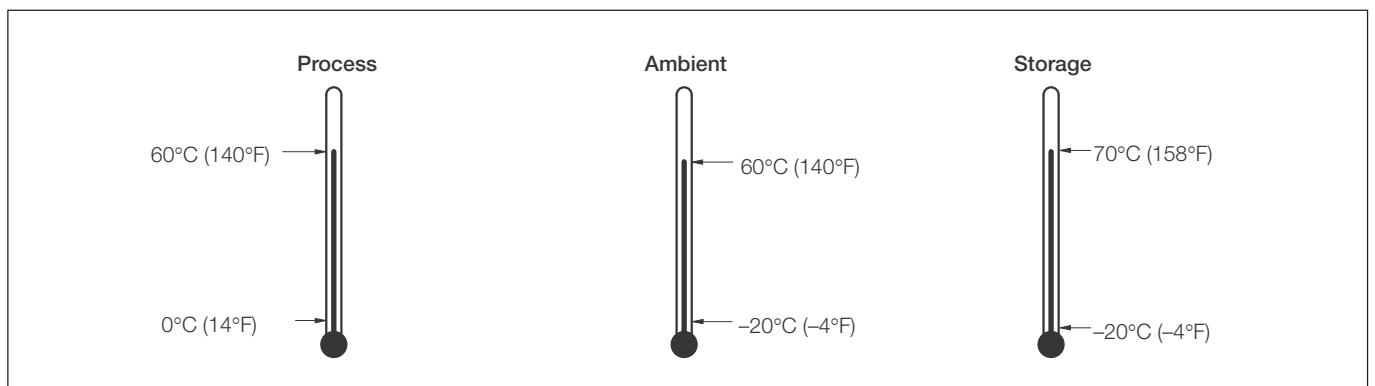

Maximum Flow

The maximum velocity depends upon the actual insertion length. Typical insertion lengths are 0.125 and 0.5 x pipe diameter.

The graph is a guide* to the maximum allowable velocity for different insertion lengths.

*The graph is intended as a guide only, factors that influence the maximum insertion length into the pipe include: probe mounting components, e.g. standoffs, bushes and valves; other influences include pipeline vibration, fluid vibration, pump noise etc.

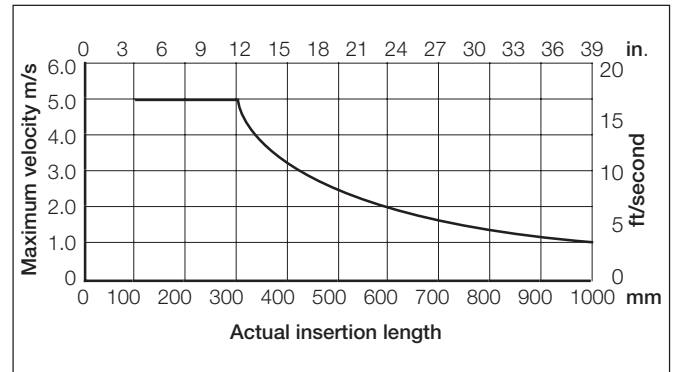

Wetted Materials

Body

Stainless steel

Probe

Suitable for potable water (UKWFBS listed)

Electrodes – stainless steel 316L

Seals

Suitable for potable water (UFWFBS listed)

...Specification

Electronic Display Unit

Mounting

Remote up to 200m (650 ft)

Housing

IP68 (NEMA 6P) aluminum alloy with glass window

or

IP65 (NEMA 4X) plastic

Electrical connections

20/16mm plastic glands, 20mm armored or accepts 1/2 in. NPT threaded or military style plug & socket

Probe cable

ABB cable supplied as standard

SWA cable available on application

Power supply

Battery life @ 0 to 50°C (32 to 122°F)

1 battery typically 1 year*

2 batteries typically 2.5 years*

* **Note.** Stated battery life assumes normal use. Extended use for flow profiling reduces battery life.

| Type | Voltage Range (V) Absolute Rating | Frequency (Hz) | VA |
|---------|--------------------------------------|----------------|-----|
| AC | 85 to 265 | 47 to 440 | <10 |
| Battery | 3.6 (Lithium) | — | — |

Outputs

Pulse and alarm outputs

Three bi-directional solid state switches with common isolation ±35V DC 50mA

Output 1 Forward only or forward plus reverse pulses

Output 2 Reverse pulses or direction indicator

Output 3 Alarm indicates any problem with measurement or with power

Pulse output 50Hz maximum, 50% nominal duty cycle

Serial data communications

Local Port RS232 compatible via ABB lead (Option)

Remote Port (Option) RS232 with RI, RTS and CTS handshaking for connection to a modem or computer

Telemetry applications using remote serial data communications

External Vodaphone WVADS Radio Pad

X25 compatible network interface via RP5, 6, 7 or similar radiopad

External PSTN modem Modern

PSTN modems which store configuration setup on non-volatile memory (for configuration information contact ABB)

External GSM modem

Siemens M20T, TC35 or similar compatible modems (for configuration information contact ABB)

Internal GSM modem

Future option

Logger Details

| | Logger | | |
|--|---------------------------|------------------|------------------------------------|
| | 1 | 2 | 3 |
| Logger Function | Flow & Pressure | Flow & Pressure | Forward, Reverse & Net Flow Totals |
| No. of Records | 8831 | 11361 | 366 |
| Logging Interval | 15 to 65500s (adjustable) | | 24 hours (fixed) |
| Typical Capacity | 3 months @ 15 mins. | ~7 days @ 1 min. | 1 year |
| Mode | Cyclic | Cyclic | Cyclic |
| Using ABB LogMaster | ✓ | ✓ | ✓ |
| Using Technolog (PMAC) | ✓ | ✓ | ✗ |
| Using Primayer Primeware | ✓ | ✓ | ✗ |
| Using OSI PI Database/IBV (WADIS) System | ✓ | ✓ | ✗ |

Pressure System – External Transducer

Pressure range absolute

10bar, 16bar or 300 psi

Connection

Standard quick-fit male probe
MIL style connector

Operating temperature range

-20 to 70°C (-4 to 158°F)

Accuracy (typical)

±0.4% of range

Thermal error band (typically 100°C [212°F])

±1.5% span

Cable length

1, 5, 10 or 20m (3, 16, 32 or 65 ft)

Response Time (Programmable)

Minimum

1s (mains-powered)
15s (battery-powered) – normal use
3s – for profiling use

Languages

English
French
German
Spanish
Italian
Dutch

Languages can be changed via Windows download program (contact ABB)

Limits of Upstream Disturbance

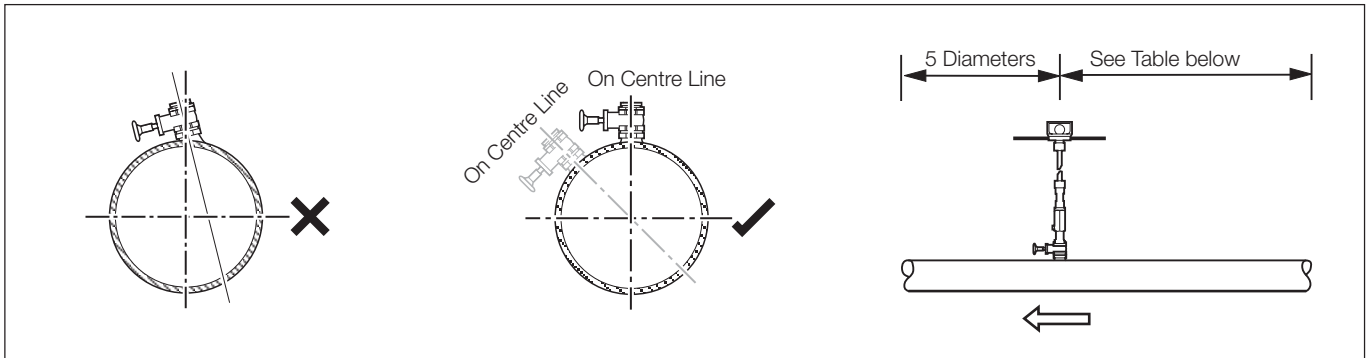

| Type of Disturbance Upstream from the Measuring Cross-Section | Minimum Upstream Straight Length* | |
|---|---|--|
| | For a measurement at the point of mean axial velocity | For a measurement on the axis of the conduit |
| 90° Elbow or a T-bend | 50 | 25 |
| Several 90° Coplanar Bends | 50 | 25 |
| Several 90° Non-coplanar Bends | 80 | 50 |
| Total Angle Convergent 18 to 36° | 30 | 10 |
| Total Angle Divergent 14 to 28° | 55 | 25 |
| Fully Opened Butterfly Valve | 45 | 25 |
| Fully Opened Plug Valve | 30 | 15 |

*Expressed in multiples of the diameter of the conduit.

Downstream from the measurement cross-section, the straight length must be at least equal to five duct diameters whatever the type of disturbance.

Note. The Table is an extract from ISO7145 (BS 1042): Section 2.2: 1982 and is reproduced with the permission of BSI. Complete copies of the standard can be obtained by post from BSI Publications, Linford Wood, Milton Keynes, MK14 6LE.

...Specification

Default Settings Table

| Configuration Parameter | Default European | Default North American |
|-------------------------------|-------------------|------------------------|
| Pulse Factor | 1 | 1 |
| Pulse Units | m ³ | Ugal |
| Totalizer Units | m ³ | Ugal |
| Flow Units | m ³ /h | MUGD |
| Velocity Units | m/s | ft/s |
| Date Format from Country Code | DDMMYY | MMDDYY |
| Flow Response Time(s) | 3 | 3 |
| Display Flow Rate | Yes | Yes |
| Display Forward Total | Yes | Yes |
| Display Reverse Total | Yes | Yes |
| Display Net Total | No | No |
| Display Date | No | No |
| Display Velocity | No | No |
| Output Option Pulse Forward | Pulses Forward | Pulses Forward |
| Output Option Pulse Reverse | Pulses Reverse | Pulses Reverse |
| Profile Factor | 1 | 1 |
| Probe Insertion Factor | 1 | 1 |

Overall Dimensions

Probe

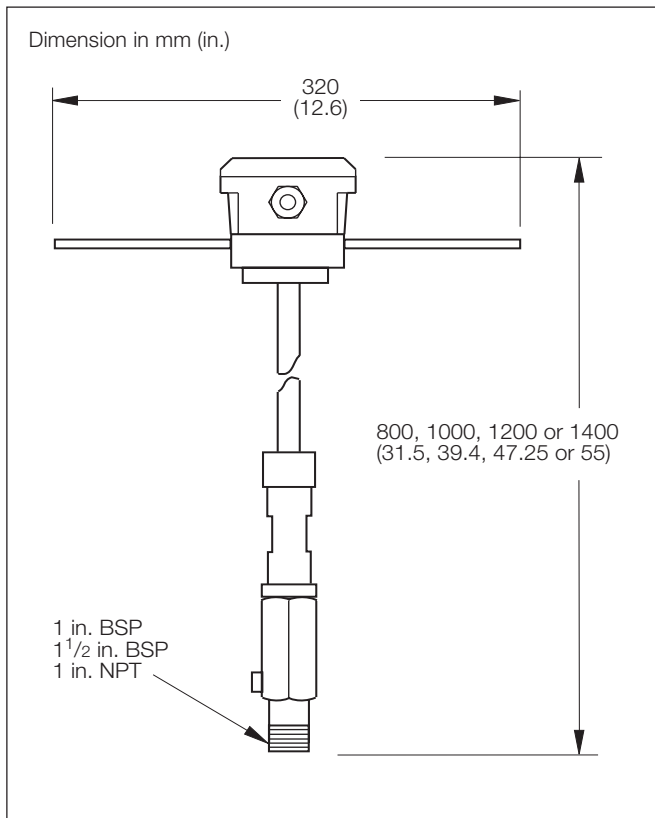

Terminal Box – Probe Mounted

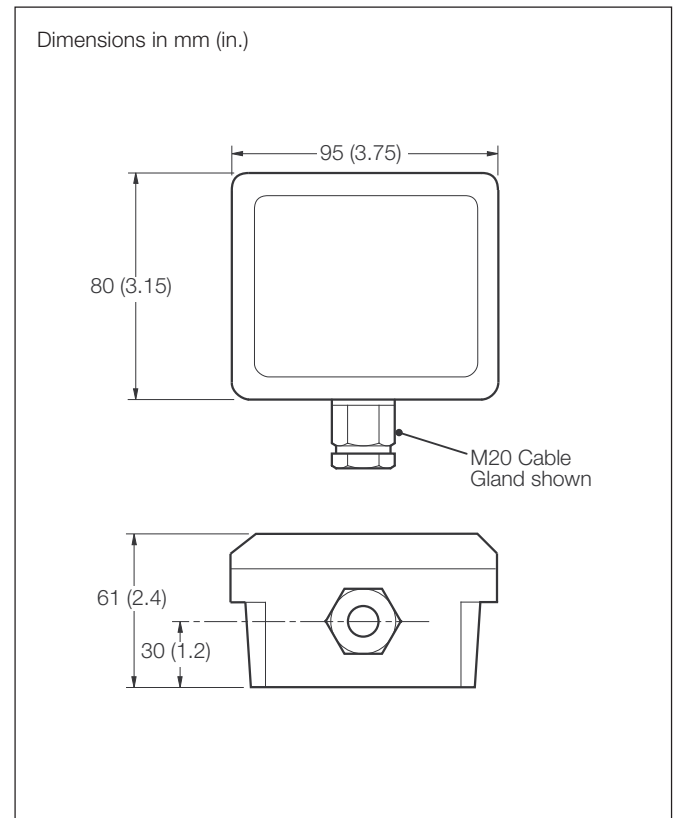

...Overall Dimensions

IP65/NEMA4X Plastic Electronic Display Unit

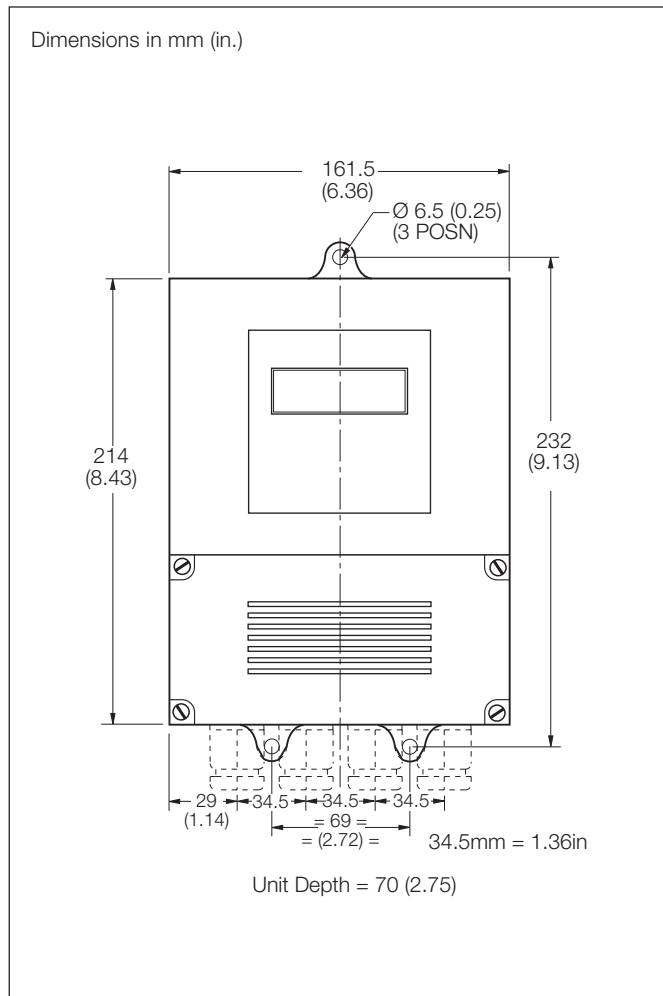

IP68/NEMA6P Electronic Display Unit

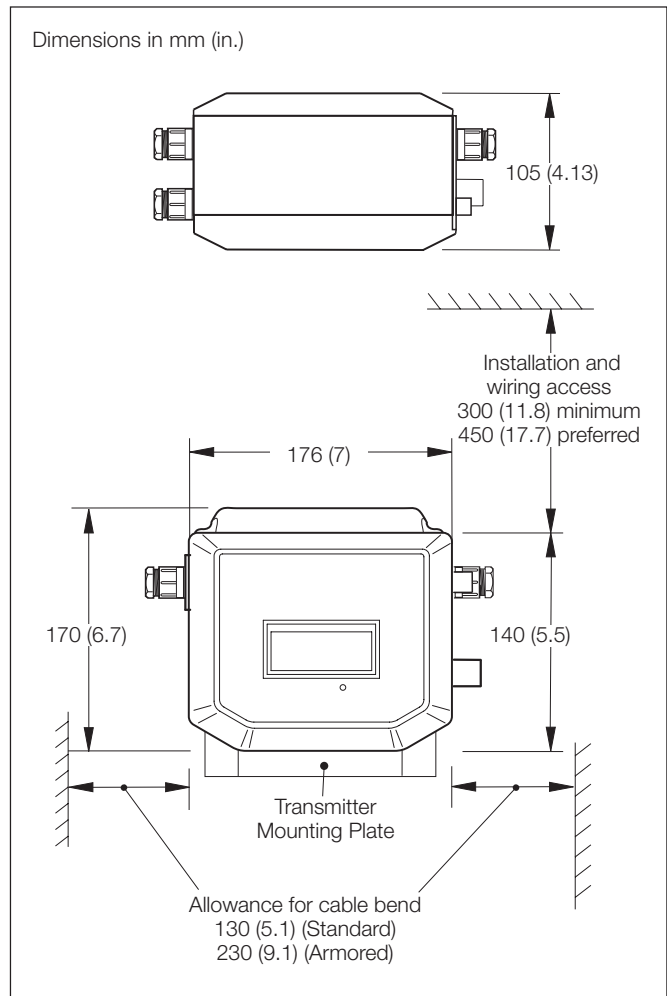

Electrical Connections

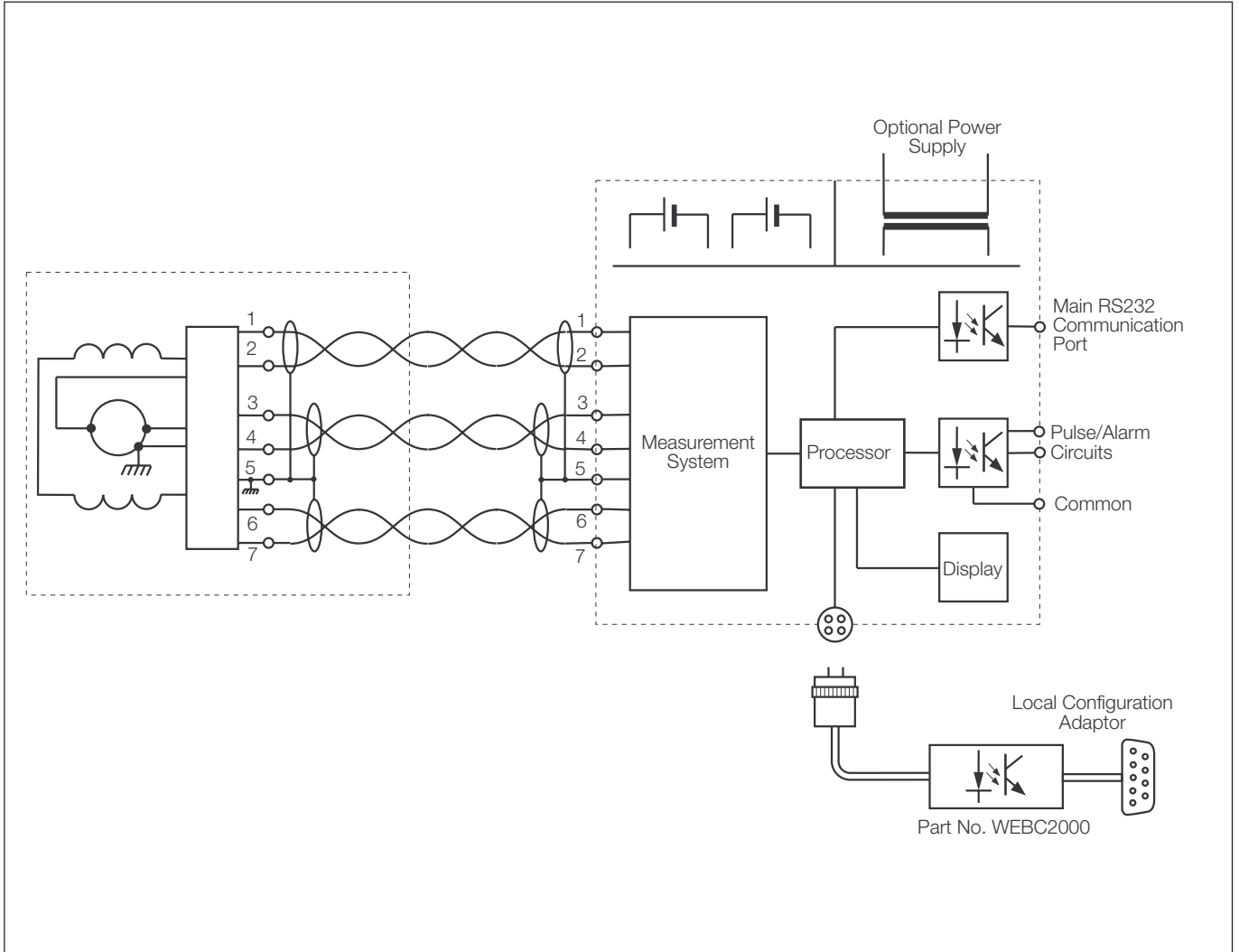

Order Information

Main Code

| | | | | | | | | | | | | |
|---|---|---|----------------------------|------------|---|---|------|---|---|---|---|---|
| Insertion-Type Electromagnetic Probe Flowmeter | | | | MM/A (PCV) | X | X | XXXX | X | X | X | X | X |
| System | | | | | | | | | | | | |
| AquaProbe Sensor/AquaMaster Transmitter | | | | A | | | | | | | | |
| Country/Language | | | | | | | | | | | | |
| Country | Language | Sliding Joint Connection | Default Cable Entry | | | | | | | | | |
| Australia | English | 1 in. BSP with 1/8 in. BSP pressure tapping | 20mm Plastic Glands | A | | | | | | | | |
| Germany | English | 1 in. BSP with 1/8 in. BSP pressure tapping | 20mm Plastic Glands | D | | | | | | | | |
| Spain | French | 1 in. BSP with 1/8 in. BSP pressure tapping | 20mm Plastic Glands | E | | | | | | | | |
| France | German | 1 in. BSP with 1/8 in. BSP pressure tapping | 20mm Plastic Glands | F | | | | | | | | |
| Holland | Spanish | 1 in. BSP with 1/8 in. BSP pressure tapping | 20mm Plastic Glands | H | | | | | | | | |
| Italy | Italian | 1 in. BSP with 1/8 in. BSP pressure tapping | 20mm Plastic Glands | I | | | | | | | | |
| UK | Dutch | 1 in. BSP with 1/8 in. BSP pressure tapping | 20mm Plastic Glands | G | | | | | | | | |
| USA | English | 1 in. NPT with 1/8 in. NPT pressure tapping | 1/2 in. NPT plugged | U | | | | | | | | |
| Probe Length mm (in.) | | | | | | | | | | | | |
| Not Required | | | | 0000 | | | | | | | | |
| 300 (12) | | | | 0300 | | | | | | | | |
| 500 (20) | | | | 0500 | | | | | | | | |
| 700 (27) | | | | 0700 | | | | | | | | |
| 1000 (39) | | | | 1000 | | | | | | | | |
| AquaMaster Transmitter Mounting/Probe Construction | | | | | | | | | | | | |
| Mounting | Construction of AquaMaster Transmitter | | | | | | | | | | | |
| Remote | Sensor & Metal Transmitter | | | 3 | | | | | | | | |
| Remote | Sensor only | | | 5 | | | | | | | | |
| Remote | Metal Transmitter | | | 8 | | | | | | | | |
| Remote | Sensor & Plastic Transmitter | | | A | | | | | | | | |
| Remote | Plastic Transmitter only | | | C | | | | | | | | |
| Power Supply | | | | | | | | | | | | |
| Power | No. of Batteries | | | | | | | | | | | |
| None (Probe only) | None (Probe only) | | | 0 | | | | | | | | |
| 95 to 240V AC + battery backup | 1 | | | A | | | | | | | | |
| Battery | 2 | | | B | | | | | | | | |
| 95 to 240V AC | 0 | | | L | | | | | | | | |
| Options | | | | | | | | | | | | |
| AquaMaster Display | AquaMaster Metal Transmitter IP Rating | AquaMaster Plastic Transmitter IP Rating | | | | | | | | | | |
| Standard | IP68 (NEMA46P) | IP65 (NEMA4X) | | 0 | | | | | | | | |
| Standard | IP68 (NEMA46P) with extra protection | N/A | | A | | | | | | | | |
| Cable Length m (ft)* | | | | | | | | | | | | |
| Remote Probes only | Lengths Supported with MIL connectors | | | | | | | | | | | |
| Not required | N/A | | | 0 | | | | | | | | |
| 10 (30) | Yes | | | 1 | | | | | | | | |
| 20 (65) | N/A | | | 2 | | | | | | | | |
| 30 (95) | Yes | | | 3 | | | | | | | | |
| 40 (130) | N/A | | | 4 | | | | | | | | |
| 50 (160) | N/A | | | 5 | | | | | | | | |
| 60 (195) | N/A | | | 6 | | | | | | | | |
| 70 (225) | N/A | | | 7 | | | | | | | | |
| 80 (260) | N/A | | | 8 | | | | | | | | |
| 100 (325) | N/A | | | A | | | | | | | | |
| 125 (410) | N/A | | | B | | | | | | | | |
| 150 (490) | N/A | | | C | | | | | | | | |
| 175 (570) | N/A | | | D | | | | | | | | |
| 200 (655) | N/A | | | E | | | | | | | | |
| Labelling/Construction | | | | | | | | | | | | |
| Company | | | | | | | | | | | | |
| ABB UK | 0 | | | | | | | | | | | |
| ABB USA | 1 | | | | | | | | | | | |

* **Note.** Cable type is dependent on Product family and gland type.

| | | | | | | | | | | Main Code | | | | | | | | Additional Code | | | | | | | | | | | | | | |
|--|--|---|--|------------------------------|--|------------------------------|--|--|--|-----------|---|---|------|---|---|---|---|-----------------|---|---|---|---|---|---|---|---|---|---|---|--|--|--|
| Insertion-Type Electromagnetic Probe Flowmeter | | | | | | | | | | MM/A | X | X | XXXX | X | X | X | X | X | X | X | X | 0 | X | X | 0 | X | X | X | X | | | |
| Seal Carrier/Body Material | | | | | | | | | | | | | | | | | | | | 0 | | | | | | | | | | | | |
| Brass | | | | | | | | | | | | | | | | | | | | 1 | | | | | | | | | | | | |
| Stainless steel | | | | | | | | | | | | | | | | | | | | | | | | | | | | | | | | |
| Cable Entries | | | | | | | | | | | | | | | | | | | | | | | | | | | | | | | | |
| Probe | | Cable Fitting and Potting to Probe | | Output | | Power | | | | | | | | | | | | | | | | | | | | | | | | | | |
| 20mm Plastic or 1/2 in. NPT* | | No | | 16mm Plastic or 1/2 in. NPT* | | 20mm Plastic or 1/2 in. NPT* | | | | | | | | | | | | 0 | | | | | | | | | | | | | | |
| 20mm Plastic | | No | | 16mm Plastic | | 20mm Plastic | | | | | | | | | | | | 1 | | | | | | | | | | | | | | |
| 20mm Armored | | No | | 20mm Armored | | 20mm Armored | | | | | | | | | | | | 2 | | | | | | | | | | | | | | |
| 1/2 in. NPT | | No | | 1/2 in. NPT | | 1/2 in. NPT | | | | | | | | | | | | 3 | | | | | | | | | | | | | | |
| 7W MIL Connector | | Yes (AM only) | | 16mm Plastic | | 20mm Plastic | | | | | | | | | | | | 5 | | | | | | | | | | | | | | |
| 7W MIL Connector | | Yes (AM only) | | 19W MIL Connector | | 20mm Plastic | | | | | | | | | | | | 6 | | | | | | | | | | | | | | |
| 20mm Plastic or 1/2 in. NPT* | | Yes | | 16mm Plastic or 1/2 in. NPT* | | 20mm Plastic or 1/2 in. NPT* | | | | | | | | | | | | A | | | | | | | | | | | | | | |
| 20mm Plastic | | Yes | | 16mm Plastic | | 20mm Plastic | | | | | | | | | | | | B | | | | | | | | | | | | | | |
| 20mm Armored | | Yes | | 20mm Armored | | 20mm Armored | | | | | | | | | | | | C | | | | | | | | | | | | | | |
| Calibration | | | | | | | | | | | | | | | | | | | | | | | | | | | | | | | | |
| Standard (3-point) | | | | | | | | | | | | | | | | | | | | | | | | | | | | | | | | |
| Uncalibrated | | | | | | | | | | | | | | | | | | | | | | | | | | | | | | | | |
| 8-point | | | | | | | | | | | | | | | | | | | | | | | | | | | | | | | | |
| Witnessed 8-point | | | | | | | | | | | | | | | | | | | | | | | | | | | | | | | | |
| Sliding Joint Connection | | | | | | | | | | | | | | | | | | | | | | | | | | | | | | | | |
| Standard, type depending on country digit/Not required | | | | | | | | | | | | | | | | | | | | | | | | | | | | | | | | |
| 1 in. BSP with 1/8 in. BSP pressure tapping | | | | | | | | | | | | | | | | | | | | | | | | | | | | | | | | |
| 1 1/2 in. BSP with 1/8 in. BSP pressure tapping | | | | | | | | | | | | | | | | | | | | | | | | | | | | | | | | |
| 1 in. NPT with 1/8 in. NPT pressure tapping | | | | | | | | | | | | | | | | | | | | | | | | | | | | | | | | |
| Communications Option | | | | | | | | | | | | | | | | | | | | | | | | | | | | | | | | |
| Not required | | | | | | | | | | | | | | | | | | | | | | | | | | | | | | | | |
| Remote Port RS232C | | | | | | | | | | | | | | | | | | | | | | | | | | | | | | | | |
| Scan Reader | | | | | | | | | | | | | | | | | | | | | | | | | | | | | | | | |
| Logger Protocol | | | | | | | | | | | | | | | | | | | | | | | | | | | | | | | | |
| Not required | | | | | | | | | | | | | | | | | | | | | | | | | | | | | | | | |
| ABB Logger enabled for ABB software | | | | | | | | | | | | | | | | | | | | | | | | | | | | | | | | |
| ABB Logger enabled for IBV software | | | | | | | | | | | | | | | | | | | | | | | | | | | | | | | | |
| ABB Logger enabled for Technolog software | | | | | | | | | | | | | | | | | | | | | | | | | | | | | | | | |
| ABB Logger enabled for Primayer software | | | | | | | | | | | | | | | | | | | | | | | | | | | | | | | | |
| Pressure Transducer/Cable Length** | | | | | | | | | | | | | | | | | | | | | | | | | | | | | | | | |
| Mounting | | Cable Length m (ft) | | | | | | | | | | | | | | | | | | | | | | | | | | | | | | |
| None | | None | | | | | | | | | | | | | | | | | | | | | | | | | | | | | | |
| Remote | | 1 (3) | | | | | | | | | | | | | | | | | | | | | | | | | | | | | | |
| Remote | | 5 (15) | | | | | | | | | | | | | | | | | | | | | | | | | | | | | | |
| Remote | | 10 (30) | | | | | | | | | | | | | | | | | | | | | | | | | | | | | | |
| Remote, not Transducer | | N/A | | | | | | | | | | | | | | | | | | | | | | | | | | | | | | |
| Pressure Span | | | | | | | | | | | | | | | | | | | | | | | | | | | | | | | | |
| Pressure Span | | | | | | | | | | | | | | | | | | | | | | | | | | | | | | | | |
| Not required | | | | | | | | | | | | | | | | | | | | | | | | | | | | | | | | |
| 10 bar (147 psi) | | | | | | | | | | | | | | | | | | | | | | | | | | | | | | | | |
| 16 bar (235.2 psi) | | | | | | | | | | | | | | | | | | | | | | | | | | | | | | | | |
| 300 psi (20.42 bar) | | | | | | | | | | | | | | | | | | | | | | | | | | | | | | | | |

Notes.

*USA only, dependent on Country/Language digit.

**For AquaMaster Transmitter in plastic enclosure with Pressure options the second output gland entry is fitted with a MIL pressure connector.

Licensing, Trademarks and Copyrights

Microsoft Excel™ and Windows™ are trademarks of the Microsoft Corp.

Technolog™ is a trademark of PMAC

Primayer™ is a trademark of Primeware

OSI™ and IBV™ are trademarks of WADIS

Vodafone Radiopad™ is a trademark of Vodafone

ABB has Sales & Customer Support
expertise in over 100 countries worldwide

www.abb.com

The Company's policy is one of continuous product
improvement and the right is reserved to modify the
information contained herein without notice.

Printed in UK (08.05)

© ABB 2004



ABB Limited
Oldends Lane, Stonehouse
Gloucestershire, GL10 3TA
UK

Tel: +44 (0)1453 826661
Fax: +44 (0)1453 829671

ABB Inc.
125 E. County Line Road
Warminster, PA 18974
USA

Tel: +1 215 674 6000
Fax: +1 215 674 7183