

■ Function

- The flowrate of liquids, slurries, pastes and sludges can be measured accurately with the electromagnetic flowmeter
- Minimum conductivity 5 $\mu\text{S}/\text{cm}$
- The measurement system consists of a flowmeter primary and a converter in a compact or remote mounted design

■ Applications

- Suitable for flow metering in the chemical and pharmaceutical industries, the food industry, in water and waste water treatment facilities and all other industry branches
- The multitude of products being metered confirms the flexibility and effectiveness of the metering principle

■ Instrument Advantages

- Simple, menu controlled operating structure
- Configure externally using a Magnetic Stick
- Integrated diagnostic/self monitoring functions
- EEPROM-Module for easiest converter exchange
- Long term, stable accuracy $\leq 0.4\%$ of rate, option $\leq 0.2\%$ of rate
- Current and pulse outputs, contact input and output user configurable
- HART-Protocol with 4...20 mA
- PROFIBUS DP



■ Important Instrument Features

- Designed in accord with PED-Directive 97/23/EC [Pressure Equipment Directive]
- Flanges per DIN/EN 1092-1/ASME/ANSI/JIS DN 3...DN 2000 [1/10" ...40"]
- Variable process connections DN 1...DN 100 [1/25" ...4"]

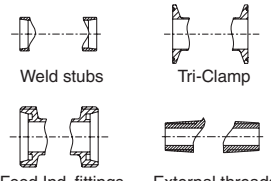
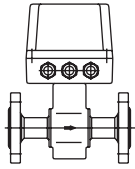

**pulsed DC magnetic field
compact and remote designs**

Overview, Flowmeter Primary and Converter Designs COPA-XM

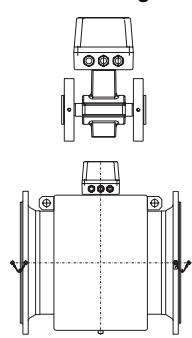
Variable Connections  DN 3 - DN 40 [1/10"-1½"] DN 50 - DN 100 [2"-4"]	Connection Types  Weld stubs Tri-Clamp Food Ind. fittings External threads Add'l types see Dimensions, others upon request	Fixed Flanges 	Wafer Design  DN 3-DN 40 [1/10"-1½"] DN 50 - DN 100 [2"-4"]	Fixed Flanges 
--	--	---	--	---

Accuracy	0.4% of rate, option 0.2% of rate	
Flowmeter primary materials	Stainless steel housing Series 2000	Alum. Series 4000

Flowmeter Primary

Model number	DM23*			DM23F		DM23W			DM43F		
Process Connections	DN	Inch	*	DN	PN	DN	Inch	PN	DN	PN	
Wafer design	3-100	1/10-4	W	-		3-50	1/10-2	10-40	-		
Flanged DIN 2501/EN1092-1	3-100	1/10-4	F	3-100	10-40	-		-		3-2000	10-40
Flanged ASME B16.5/ JIS B2210-10K	3-100	1/10-4	F	1/10"-4"	CL150-300/JIS	-		-		1/10"-40"	CL150/JIS 1/10"-12" CL300
Food ind. fitting DIN 11851	3-100	1/10-4	S	-		-		-		-	
Weld stubs ISO 1127	3-100	1/10-4	J	-		-		-		-	
DIN 11850	3-100	1/10-4	R	-		-		-		-	
DIN 2463	3-100	1/10-4	Q	-		-		-		-	
ISO 2037	3-100	1/10-4	P	-		-		-		-	
SMS	25-100	1-4	X	-		-		-		-	
Tri-Clamp DIN 32676	3-100	1/10-4	T	-		-		-		-	
ASME BPE	3-100	1/10-4	K	-		-		-		-	
External threads ISO 228	3-25	1/10-1	E	-		-		-		-	
1/8" Sanitary connector	1-2	1/25-1/12	B	-		-		-		-	
Liner	PFA (vacuum-proof) (> DN 2) PEEK, Torton (< DN 3)			PFA (vacuum-proof)		PFA (vacuum-proof)			Hard/soft rubber, PTFE, PFA, others		
Conductivity	≥ 5 µS/cm (20 µS/cm for demineralized water)										
Electrodes	SST No. 1.4571 [316Ti], 1.4539 [904L], Hastelloy B-3/C-4, Platinum-Iridium, Tantalum, Titanium										
Process connection material	SST No. 1.4404 [316L], 1.4571[316Ti], PVC, POM			SST No. 1.4571 [316Ti]		-			Steel, SST No. 1.4571 [316Ti]		
Protection Class	IP 67			IP 67		IP 67			IP 67		
Fluid temperature	-25 to 130 °C			-40 to 130 °C		-25 to 130 °C			-25 to 130 °C		

Approvals

Official calibration	Cold water and waste water, fluids other than water
Press. equipm. directive 97/23/EC	Conformity assessment in accordance with category III, fluid group 1
CRN (Canadian Regist. Number)	on request

Approvals

Hygienic & sterile requirements	CIP/SIP-capable, EHEDG (Cleanability)	CIP/SIP-capable	CIP-capable
---------------------------------	--	-----------------	-------------

Converter

Supply power	24 V, 115 V, 230 V AC, 24 V DC
Current output standard	0/2-10 mA, 0-5 mA, 0/4-20 mA, 0/4-10/12-20 mA
Pulse output, 1-channel std.	active, 24 V, optocoupler
Ext. zero return	yes
Ext. totalizer reset	yes
Forward/reverse metering	yes
Data link	RS485, PROFIBUS DP
Communication	ASCII-Protocol, PROFIBUS DP, HART-Protocol®
Fluid monitoring std.	yes, from DN 10 [3/8"]
Self monitoring/Diagnostic	yes
Local display/totalization	yes
2 Flow ranges	yes, switching automatic or externally
Preset counter	yes, START/STOP using contact input, stop using contact output
Density correction	yes, manual entry (totalizer and display in weight units)

¹⁾ 25 °C if the process connection is made of stainless steel; -10 °C if the process connection is made of steel

Overview, Flowmeter and Converter Designs MAG-XM

Variable Connections	Connection Types			Fixed Flanges	Wafer Design	Fixed Flanges							
	 Weld stubs Tri-Clamp Food Ind. fittings External threads Add'l types see Dimensions, others upon request		 DN 3-DN 40 [1/10"-1½"] DN 50 - DN 100 [2"-4"]										
Accuracy	0.4% of rate, option 0.2% of rate												
Flowmeter primary materials	Stainless steel housing Series 2000				Alum Series 4000								
Flowmeter Primary													
Model number	DM21*			DM21F	DM21W	DM41F							
Process Connections	DN	Inch	*	DN	PN	DN	Inch	PN	DN	PN			
Wafer design	3-100	1/10-4	W	-	-	3- 50	1/10-2	10-40	65-100	2½-4	10-16	-	-
Flanged DIN 2501/EN 1092-1	3-100		F	3-100	10-40				3-2000	10-40			
Flanged ASME B16.5/ JIS B2210-10K	3-100	1/10-4	F	1/10"-4"	CL150-300/JIS				1/10"-40"	CL150/JIS			
Food ind. fitting DIN 11851	3-25	1/10-1	S										
Weld stubs ISO 1127	3-100	1/10-4	J										
DIN 11850	3-100	1/10-4	R										
DIN 2463	3-100	1/10-4	Q										
ISO 2037	3-100	1/10-4	P										
SMS	25-100	1-4	X										
Tri-Clamp DIN 32676	3-100	1/10-4	T										
ASME BPE	3-100	1/10-4	K										
External threads ISO 228	3-25	1/10-1	E										
1/8" Sanitary connector	1-2	1/25-1/12	B										
Liner	PFA (vacuum-proof) (> DN 2) PEEK, Torton (< DN 3)			PFA (vacuum-proof)		PFA (vacuum-proof)			Hard/soft rubber, PTFE, PFA, others				
Conductivity	≥ 5 µS/cm (20 µS/cm for demineralized water)												
Electrodes	SST No. 1.4571[316Ti], 1.4539 [904L], Hastelloy B-3/C-4, Platinum-Iridium, Tantalum, Titanium												
Process connection material	SST No. 1.4404 [316L]			SST No. 1.4571 [316Ti]			-			Steel, SST No.1.4571 [316Ti]			
Protection Class	IP 67 / IP 68			IP 67 / IP 68			IP 67 / IP 68			IP 67 / IP 68			
Fluid temperature	-25 to 130 °C			-40 to 130 °C			-25 to 130 °C			-25 to 130 °C / 180 °C			
Approvals													
Official calibration	Cold water and waste water, fluids other than water												
Press. equip. directive 97/23/EC	Conformity assessment in accordance with category III, fluid group 1												
CRN (Canadian Regist. Number)	on request												
Approvals													
Hygienic & sterile requirements	CIP/SIP-capable, EHEDG (Cleanability), 3A ²⁾			CIP/SIP-capable				CIP-capable					
Converter													
Model number	50XM2000												
Supply power	24 V, 115 V, 230 V AC, 24 V DC												
Current output standard	0/2-10 mA, 0-5 mA, 0/4-20 mA, 0/4-10/12-20 mA												
Pulse output, 1-channel std.	active, 24 V, optocoupler												
Ext. zero return	yes												
Ext. totalizer reset	yes												
Forward/reverse metering	yes												
Data link	RS485, PROFIBUS DP												
Communication	ASCII-Protocol, PROFIBUS DP, HART-Protocol®												
Fluid monitoring std.	yes, from DN 10 [3/8"]												
Self monitoring/Diagnostic	yes												
Local display/totalization	yes												
2 Flow ranges	yes, automatic or external switching												
Preset counter	yes, START/STOP using contact input, stop using contact output												
Density correction	yes, manual entry (totalizer and display in weight units)												
Housing	Field mount housing												

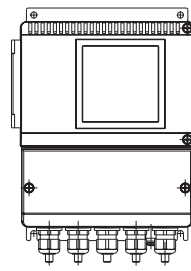

¹⁾ 25 °C if the process connection is made of stainless steel -10 °C if the process connection is made of steel
²⁾ The approvals apply to DN3...DN100. Please observe the special installation conditions. See the operating instructions.

Accuracy, Reference Conditions and Principle of Operation

Reference Conditions per EN 29104

Fluid Temperature

20 °C ± 2 K

Ambient Temperature

20 °C ± 2 K

Supply Power

Nominal voltage per name plate $U_N \pm 1\%$

Test Reference Installation Conditions, Straight Pipe Sections

Upstream > 10 x D,
 Downstream > 5 x D,
 D = Flowmeter primary size
 Please note the COPA-XM/MAG-XM Operating Instruction.

Warm Up Phase

30 min

Effect on Analog Output

Same as pulse output plus ± 0.1% of rate

Temperature Effects

0.1% of rate /10 °C

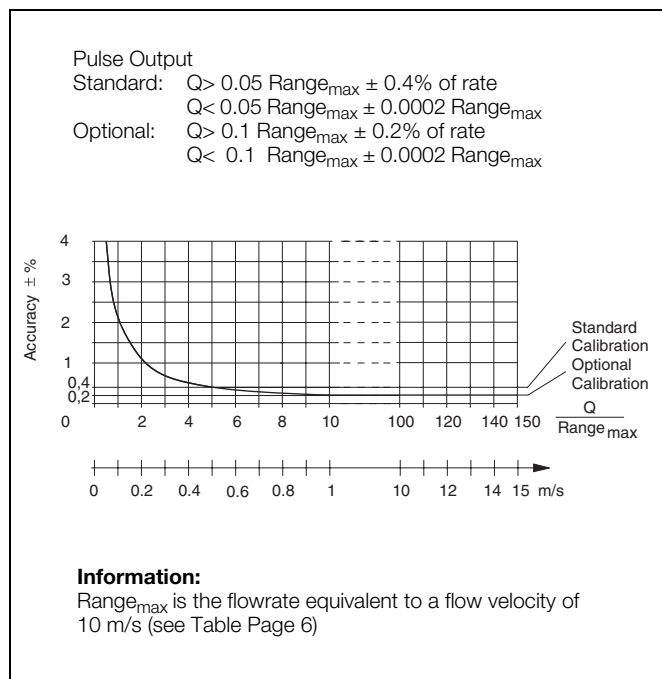

Fig. 1: Accuracy

Principle of Operation

Faraday’s Laws of Induction form the basis for the electromagnetic flowmeters. It states that a voltage is induced in a conductor as it moves through a magnetic field.

This principle is applied to a conductive fluid which flows through a magnetic field generated perpendicular to the flow direction (see Schematic).

The voltage induced in the fluid is measured at two electrodes, installed diametrically opposite to each other. This signal voltage U_E is proportional to the magnetic induction B, the electrode spacing D and the average flow velocity v.

Noting that the magnetic induction B and the electrode spacing D are constants, indicates that a proportionality exists between the signal voltage U_E and the average flow velocity v. The equation for the volume flow shows that the signal voltage U_E is linear and proportional to the volume flowrate.

The induced signal voltage is processed in the converter into scaled, analog and digital signals.

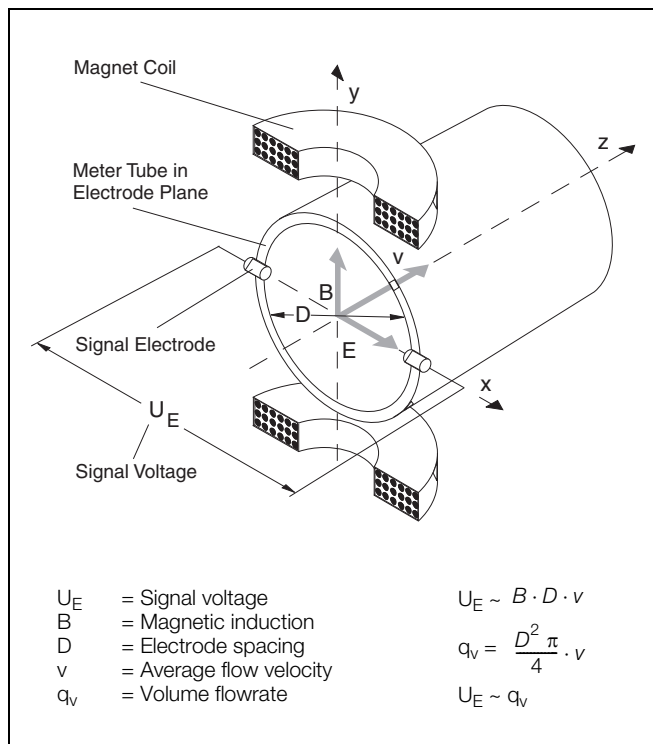

Fig. 2: Electromagnetic Flowmeter Schematic

Installation Requirements and Flowmeter Primary Grounding Procedures

In- and Outlet Straight Sections

The measurement principle is independent of the flow profile as long as eddies do not extend into the region where the measurements are made, e.g. after double elbows in 2 planes, tangential entries or partially opened gate valves installed directly upstream from the flowmeter. In such situations measures to normalize the flow profile are required. It is recommended that flow control devices be installed downstream from the flowmeter primary.

Grounding

Grounding the flowmeter primary is necessary not only for safety reasons but also to assure proper operation of the electromagnetic flowmeter. The grounding screws on the flowmeter primary, which correspond to VDE 0100, Part 540, are to be connected to earth potential. For measurement reasons this potential should be identical to the fluid potential if at all possible.

In applications using plastic or insulating lined pipelines the ground connections are made utilizing grounding plates or grounding electrodes. If stray currents are present in the pipeline, grounding plates up- and downstream of the flowmeter primary are recommended.

Electrode Axis

Neither electrode should be positioned at the highest point in the pipeline in horizontal installations. Gas bubbles, which may be present in the fluid, could interrupt the electrical connection between the electrodes and the fluid. An ideal installation is shown in Fig. 3. Assure that the meter tube is always completely filled with fluid. Instrument designs with removable electrodes for cleaning are available upon request.

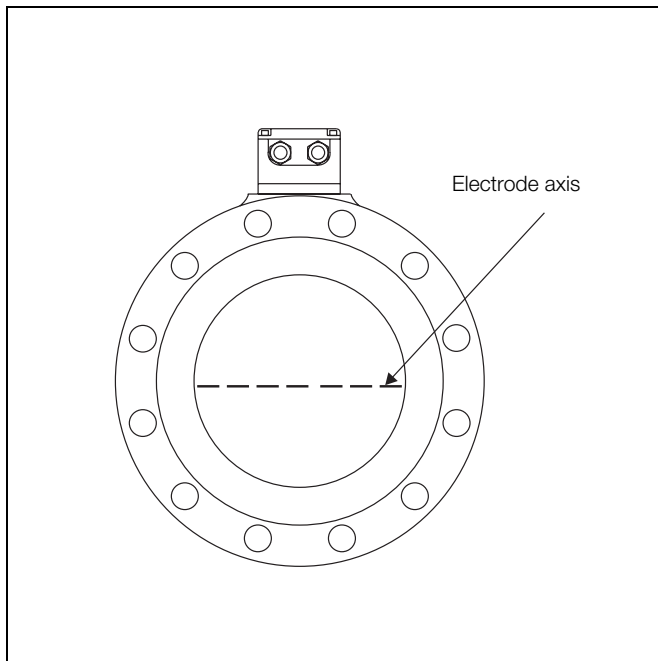

Fig. 3: Electrode Axis

Installations in Larger Size Pipelines

The flowmeter can be installed in larger size pipelines without problems using reducer sections. The pressure drop when reducers are used can be determined from the Nomograph, Fig. 4. The procedure for determining the pressure drop is as follows:

1. Calculate the diameter ratio d/D .
2. Calculate the flow velocity as a function of the flowmeter size and the flowrate:

$$v = \frac{Q \text{ (Flowrate)}}{\text{Flowmeter Primary Constant}}$$

The flow velocity can also be determined from the Flowrate Nomographs, Fig. 16 and Fig. 17.

3. In Fig. 4 read the "Pressure drop" value, y-axis, at the intersection of the "Diameter Ratio", x-axis, and the "Flow Velocity" curve.

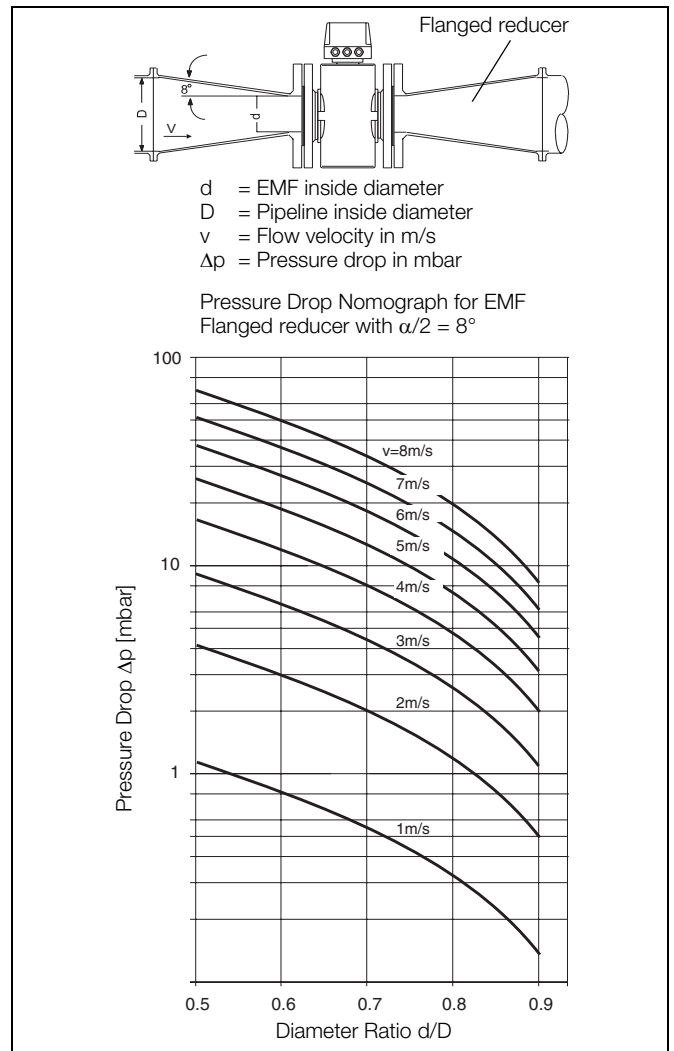

Fig. 4: Pressure Drop Nomograph

Specifications Flowmeter Primary

Meter Size		Std. Press. Rating PN	Min. Flow Range Flow Velocity. 0 to 0.5 m/s	Max. Flow Range Flow Velocity. 0 to 10 m/s	Max. Flow Range Flow Velocity. 0 to 15 m/s
DN	Inch				
1	1/25	10	0 to 0.03 l/min	0 to 0.6 l/min	0 to 0.9 l/min
1.5	1/16	10	0 to 0.06 l/min	0 to 1.2 l/min	0 to 1.8 l/min
2	1/12	10	0 to 0.1 l/min	0 to 2 l/min	0 to 3 l/min
3	1/10	40	0 to 0.2 l/min	0 to 4 l/min	0 to 6 l/min
4	5/32	40	0 to 0.4 l/min	0 to 8 l/min	0 to 12 l/min
6	1/4	40	0 to 1 l/min	0 to 20 l/min	0 to 30 l/min
8	5/16	40	0 to 1.5 l/min	0 to 30 l/min	0 to 45 l/min
10	3/8	40	0 to 2.25 l/min	0 to 45 l/min	0 to 67.5 l/min
15	1/2	40	0 to 5 l/min	0 to 100 l/min	0 to 150 l/min
20	3/4	40	0 to 7.5 l/min	0 to 150 l/min	0 to 225 l/min
25	1	40	0 to 10 l/min	0 to 200 l/min	0 to 300 l/min
32	1-1/4	40	0 to 20 l/min	0 to 400 l/min	0 to 600 l/min
40	1-1/2	40	0 to 30 l/min	0 to 600 l/min	0 to 900 l/min
50	2	40	0 to 3 m ³ /h	0 to 60 m ³ /h	0 to 90 m ³ /h
65	2-1/2	40	0 to 6 m ³ /h	0 to 120 m ³ /h	0 to 180 m ³ /h
80	3	40	0 to 9 m ³ /h	0 to 180 m ³ /h	0 to 270 m ³ /h
100	4	16	0 to 12 m ³ /h	0 to 240 m ³ /h	0 to 360 m ³ /h
125	5	16	0 to 21 m ³ /h	0 to 420 m ³ /h	0 to 630 m ³ /h
150	6	16	0 to 30 m ³ /h	0 to 600 m ³ /h	0 to 900 m ³ /h
200	8	10/16	0 to 54 m ³ /h	0 to 1080 m ³ /h	0 to 1620 m ³ /h
250	10	10/16	0 to 90 m ³ /h	0 to 1800 m ³ /h	0 to 2700 m ³ /h
300	12	10/16	0 to 120 m ³ /h	0 to 2400 m ³ /h	0 to 3600 m ³ /h
350	14	10/16	0 to 165 m ³ /h	0 to 3300 m ³ /h	0 to 4950 m ³ /h
400	16	10/16	0 to 225 m ³ /h	0 to 4500 m ³ /h	0 to 6750 m ³ /h
500	20	10	0 to 330 m ³ /h	0 to 6600 m ³ /h	0 to 9900 m ³ /h
600	24	10	0 to 480 m ³ /h	0 to 9600 m ³ /h	0 to 14400 m ³ /h
700	28	10	0 to 660 m ³ /h	0 to 13200 m ³ /h	0 to 19800 m ³ /h
800	32	10	0 to 900 m ³ /h	0 to 18000 m ³ /h	0 to 27000 m ³ /h
900	36	10	0 to 1200 m ³ /h	0 to 24000 m ³ /h	0 to 36000 m ³ /h
1000	40	10	0 to 1350 m ³ /h	0 to 27000 m ³ /h	0 to 40500 m ³ /h
1200	48	6	0 to 2100 m ³ /h	0 to 42000 m ³ /h	0 to 63000 m ³ /h
1400	54	6	0 to 2700 m ³ /h	0 to 54000 m ³ /h	0 to 81000 m ³ /h
1600	64	6	0 to 3600 m ³ /h	0 to 72000 m ³ /h	0 to 108000 m ³ /h
1800	72	6	0 to 4500 m ³ /h	0 to 90000 m ³ /h	0 to 135000 m ³ /h
2000	80	6	0 to 5700 m ³ /h	0 to 114000 m ³ /h	0 to 171000 m ³ /h

Flanged Design and Pressure Ratings

Meter Size DN / Inch	Flanges ¹⁾	Material	PN	PED
3-25 1/10"-1"	DIN ASME JIS	SST No. 1.4571 [316Ti] or Steel	40 bar CL 150, CL 300 10 bar	SEP Art.3 Par. 3
32 1-1/4"	DIN ASME JIS	SST No. 1.4571 [316Ti] or Steel	40 bar CL 150, CL 300 10 bar	Certificate of Compliance for Category III, Module B1 + D, Fluid Group 1
40 1-1/2"	DIN ASME JIS	SST No. 1.4571 [316Ti] or Steel	40 bar CL 150, CL 300 10 bar	
50 2"	DIN ASME JIS	SST No. 1.4571 [316Ti] or Steel	40 bar CL 150, CL 300 10 bar	
65 2-1/2"	DIN ASME JIS	SST No. 1.4571 [316Ti] or Steel	16, 40 bar CL 150, CL 300 10 bar	
80 3"	DIN ASME JIS	SST No. 1.4571 [316Ti] or Steel	40 bar CL 150, CL 300 10 bar	
100 4"	DIN ASME JIS	SST No. 1.4571 [316Ti] or Steel	16, 40 bar CL 150, CL 300 10 bar	
125 5"	DIN ASME	SST No. 1.4571 [316Ti] or Steel	16, 40 bar CL 150, CL 300	
150 6"	DIN ASME	SST No. 1.4571 [316Ti] or Steel	16, 40 bar CL 150, CL 300	
200 8"	DIN ASME	SST No. 1.4571 [316Ti] or Steel	10, 16, 25, 40 bar CL 150, CL 300	
250 10"	DIN ASME	SST No. 1.4571 [316Ti] or Steel	10, 16, 25, 40 bar CL 150, CL 300	
300 12"	DIN ASME	SST No. 1.4571 [316Ti] or Steel	10, 16, 25, 40 bar CL 150, CL 300	
350-600 14"-24"	DIN ASME	SST No. 1.4571 [316Ti] or Steel	10, 16, 25, bar CL 150	
700-1000 28"-40"	DIN ASME	SST No. 1.4571 [316Ti] or Steel	10, 16, 25, bar CL 150	
1200-2000 48"-80"	DIN	SST No. 1.4571 [316Ti] or Steel	6, 10, 16, bar	

¹⁾ Connection dimensions for flanges acc. to DIN 2501/EN1092-1 or ASME B16.5 or JIS B2210-10K.

Information:

The flow range end value can be set anywhere between 0.5 and 15 m/s, even though the flow rate nomographs on Page 10 only cover a range from 0.5 to 10 m/s. (For max. flow range end values see last column in the above table).

Max. Allowable Cleaning Temperature

CIP-cleaning	Liner Flowmeter Primary	T _{max} . °C	t _{max} Minutes	T _{Amb.} °C
Steam cleaning	PTFE, PFA,	150	60	25
Liquid cleaning	PTFE, PFA,	140	60	25

If the ambient temperature >25 °C, the difference must be subtracted from the max. cleaning temperature. T_{max} - Δ °C. Δ °C = (T_{Amb.} - 25 °C)

Min. allowable Pressure and Fluid Temperature

Liner material	Meter size DN	P _{Operation} mbar abs	at T _{Operation} °C
Hard rubber	15 to 2000	0	< 90
Soft rubber	50 to 2000	0	< 90
PTFE	10 to 600	270	< 20
		400	< 100
		500	< 130
Thick PTFE High temperature design	25 to 80 100 to 250 300	0	< 180
		67	< 180
		27	< 180
PFA	3 to 100	0	< 130

Ambient conditions¹⁾

Ambient Temperature: -25 °C/-10 °C to +60 °C

Fluid temperature: -25 °C/-10 °C to +130 °C/+180 °C

Storage temperature: -25 °C/-10 °C to +70 °C

Temperature Diagram (Model DM43F) DM23F

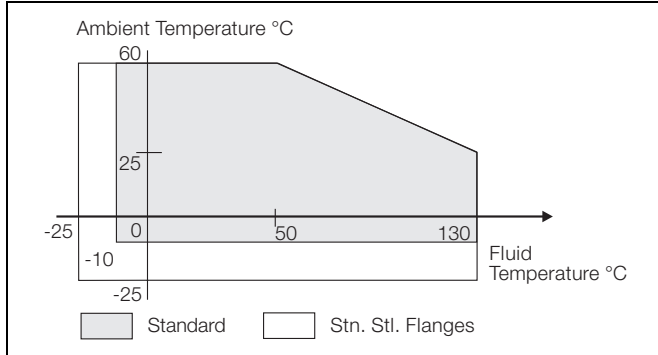

Fig. 5: Fluid Temperature as a Function of the Ambient Temperature, Model FXM2000-DM43F

Temperature Diagram (Model DM41F) DM21F

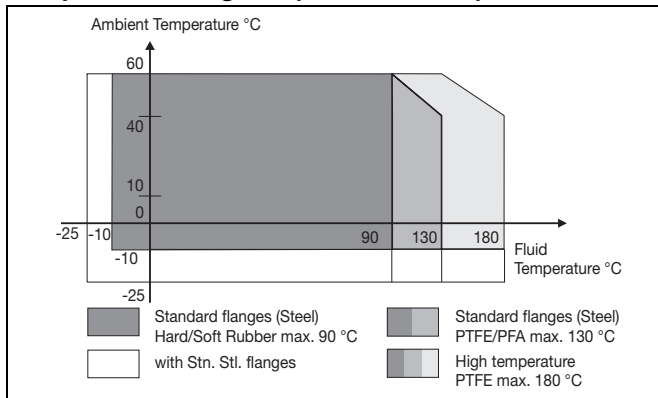

Fig. 6: Fluid Temperature as a Function of the Ambient Temperature, Model FXM2000-DM41F

¹⁾ **Note:** Extended lower temperature range only for devices equipped with a stainless-steel flange. Extended upper temperature range only for a high-temperature variant.

Implementation of the Directive 97/23/EG „Pressure Equipment Directive“

The Pressure Equipment Directive is implemented as follows:

- Classify all instruments as Category III (Pipelines for gaseous Liquids, Group 1)
- Compliance evaluation per module combination B1 and D
 - B1: EU proposed test by a certified authority (TÜV)
 - D: Evaluation and monitoring of the QA-system for the manufacture, test and inspection by a certified authority (TÜV)
- Fulfillment of the safety requirements through use of the AD-2000-Pamphlets

Exceptions to the Directive:

Flowmeter sizes DN 1 to DN 25 [1/25" - 1"] are manufactured according to SEP Art. 3 Par. 3 and do not receive a CE-Mark. The flowmeter sizes DN 700 to DN 2000 [28"-80"] are assigned according to Art. 1 Par. (3) No. 3.2. These are used in water supply and distribution networks and for the flow of waste water together with the connected equipment within the application range of the Directive.

Material Strength Curves

Liners: PTFE, PFA, Hard/Soft Rubber (limited to 90 °C)

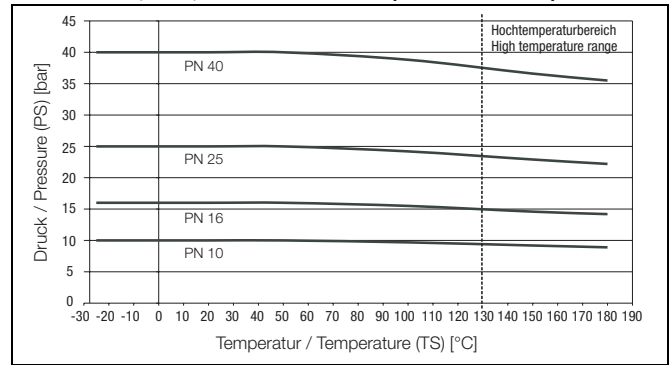

Fig. 7: DIN-Flanges SS No.1.4571[316Ti] to DN 600

Liners: PTFE, Hard/Soft Rubber (limited to 90 °C)

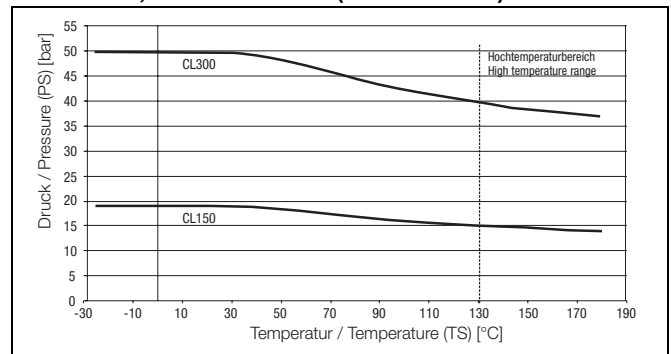

Fig. 8: ASME/ANSI-Flanges SS No.1.4571[316Ti] to 24"

Liners: PTFE, Hard/Soft Rubber (limited to 90 °C)

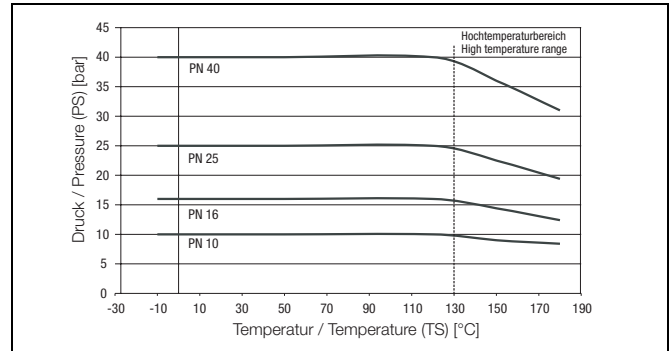

Fig. 9: DIN-Flanges Steel to DN 600

Liners: PTFE, Hard/Soft Rubber (limited to 90 °C)

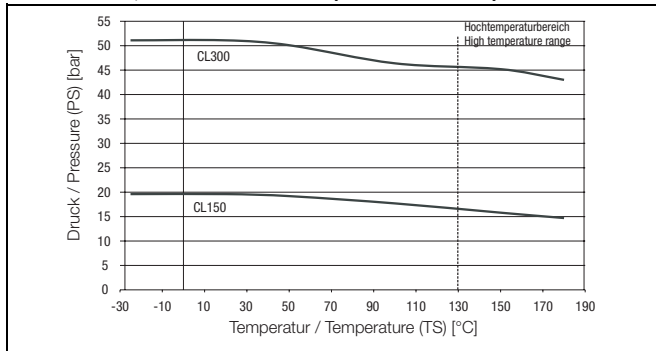

Fig. 10: ASME-Flanges Steel to 24"

Liners Hard/Soft Rubber

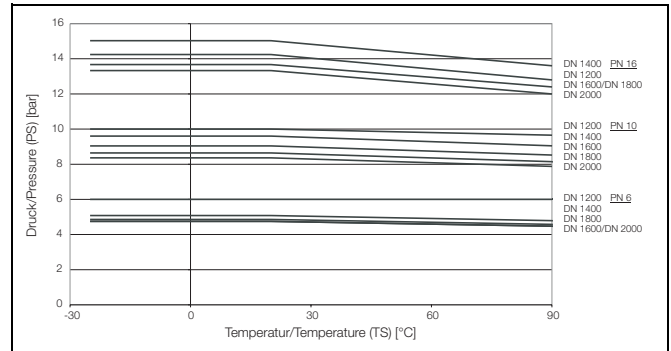

Fig. 13: DIN-Flanges SST No. 1.4571 [316Ti] DN 1200 - DN 2000

JIS B2210-10K Flange SST No. 1.4571 [316Ti] or Steel

Meter Size DN	Material	PN	TS [°C]	PS [bar]
32-100	SST No.1.4571 [3156Ti]	10	-25 to +180	10
32-100	Steel	10	-10 to +180	10

Liners: PTFE, Hard/Soft Rubber (limited to 90 °C)

Liners: Hard/Soft Rubber

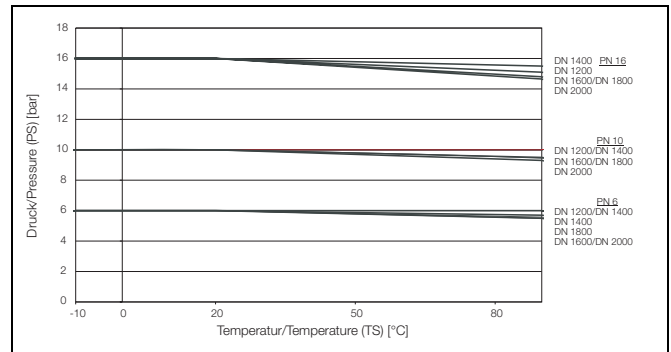

Fig. 14: DIN-Flanges Steel DN 1200 - DN 2000

Liners: Hard/Soft Rubber ≤ 90 °C

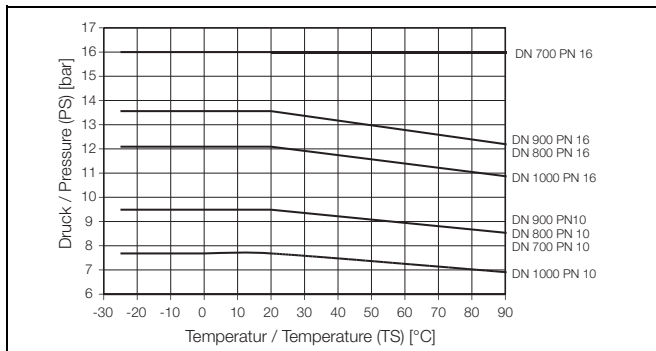

Fig. 11: DIN-Flanges SST No. 1.4571 [316Ti] ≤ DN 1000

Liners: Hard/Soft Rubber ≤ 90 °C

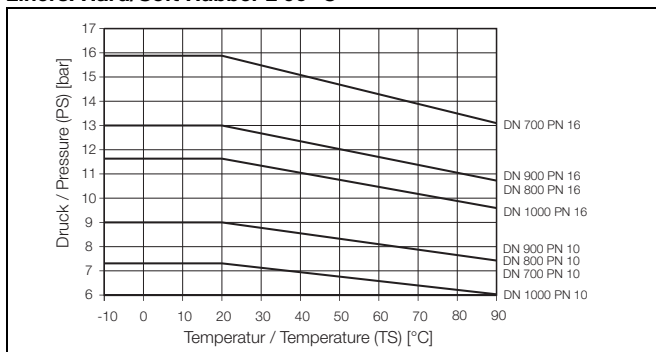

Fig. 12: DIN-Flanges Steel ≤ DN 1000

Protection Class per EN 60529

IP 67 Standard
 IP 68 (only for MAG-XM DM41F/DM21 possible)

Pipeline vibration following EN 60068-2-6**The following applies to compact devices (COPA):**

In the range of 10...55 Hz, max. deflection 0.15 mm
 In the range of 55...150Hz, max. acceleration 2 g

The following applies to devices with a separate measurement converter:

In the range of 10...55 Hz, max. deflection 0.15 mm

Design**Meter Tube**

Stainless steel No. 1.4301 [304]

DN 3 to DN 400

DM41/43F: dual-shell casing: cast aluminum, coated¹⁾
 DM21/23F: deep-drawn casing, stainless steel no. 1.4301

Flanges

Steel galvanized standard
 Stainless steel 1.4571 [316Ti] (\leq DN15 [1/2"] and DM21/23F standard)

DN 500 to DN 2000

Welded steel construction, painted¹⁾

Flanges

Steel, painted standard
 Stainless steel 1.4571 [316Ti]

Connection Box**DM41F/DM43F/DM23F**

Cast aluminum, coated
 Paint coat thickness 60 μ m
 Frame: RAL 7012
 Cover: RAL 9002

DM21F

Stainless steel no. 1.4301

Weight

See Dimensions Drawings

Laid Length Flanged (Short Design)

Meter sizes DN 3 – DN 400 [1/10" – 16"] correspond to the lengths defined in DIN Flange Design VDE/VDI 2641 and DVGW Working Paper W420 (Water Totalizer, Design WP ISO 4064 Short as well as ISO 13359).

ASME B16.5 CL 150/CL 300 (other upon request)

With PFA, flanged (ISO laid length)

ASME B16.5 CL 150/CL 300 (other upon request)

With PTFE, hard/soft rubber
 Laid length Series 1000 or ISO laid length
 Protection flanges for laid length Series 1000 L+20 mm \leq DN 80 [3"]
 L+25 mm from DN 100 [4"] can be specified.

¹⁾ Paint coat 60 μ m thick, RAL 9002

Flowrate Nomographs

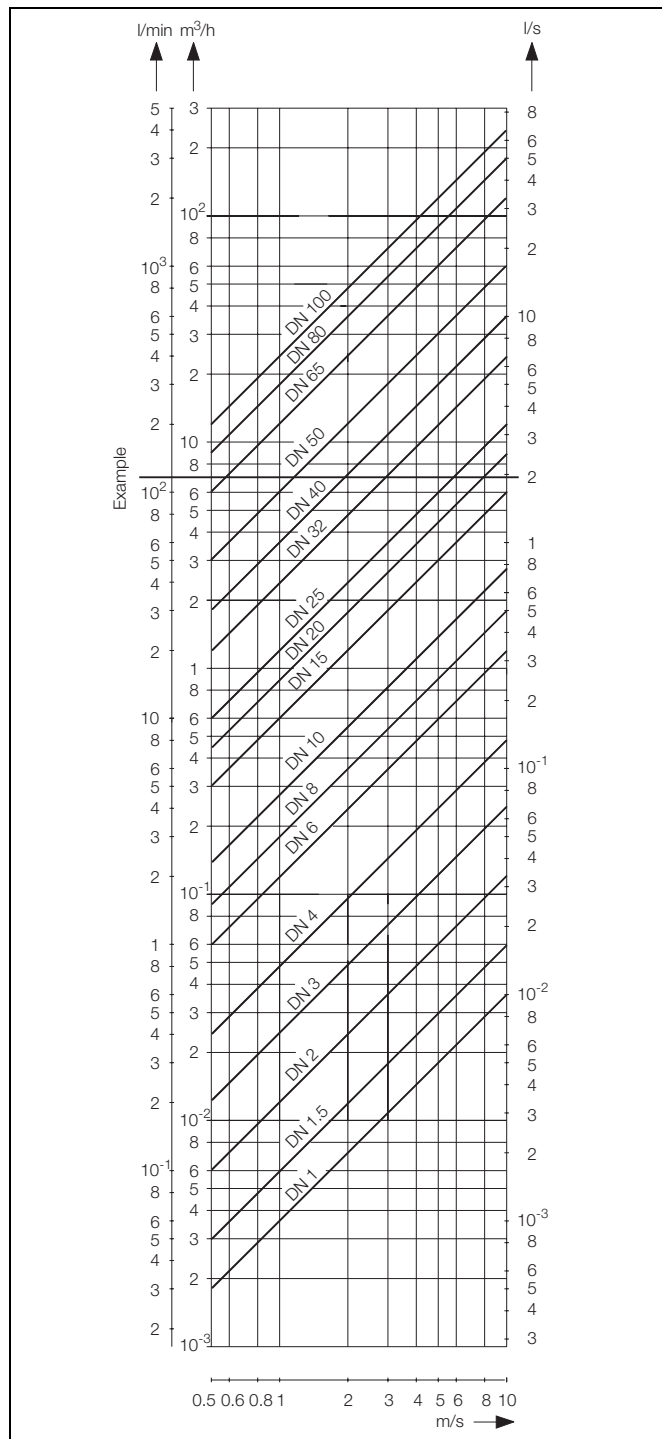

Fig. 15: Flowrate Nomograph DN 1 to DN 100 [1/25" to 4"]

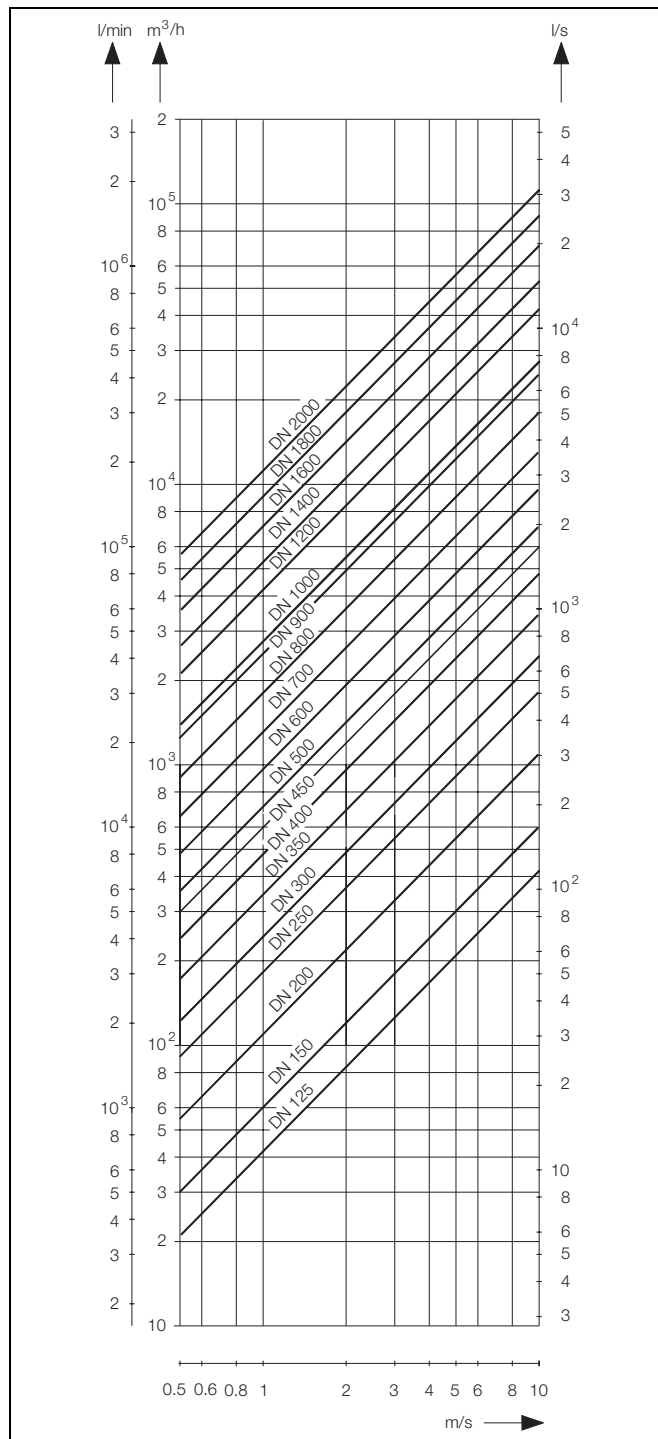

Fig. 16: Flowrate Nomograph DN 125 to DN 2000 [5" to 80"]

Flowrate Nomograph

The volume flowrate is a function of the flow velocity and the flowmeter size. The Flowrate Nomographs, Fig. 16 and Fig. 17, indicate the flowrate range for a specific flowmeter size and which flowmeter sizes are suitable for a specific flowrate.

Example:

Flowrate = 7 m³/h (maximum value = range end value). Suitable are flowmeter sizes DN 20 to DN 65 [3/4" to 2-1/2"] for a flow velocity between 0.5 and 10 m/s.

Dimension Drawings Flowmeter Primaries DN 3 to DN 400 [1/10" to 12"], DIN/EN1092-1⁵⁾ Flanges Models DM43F and DM41F

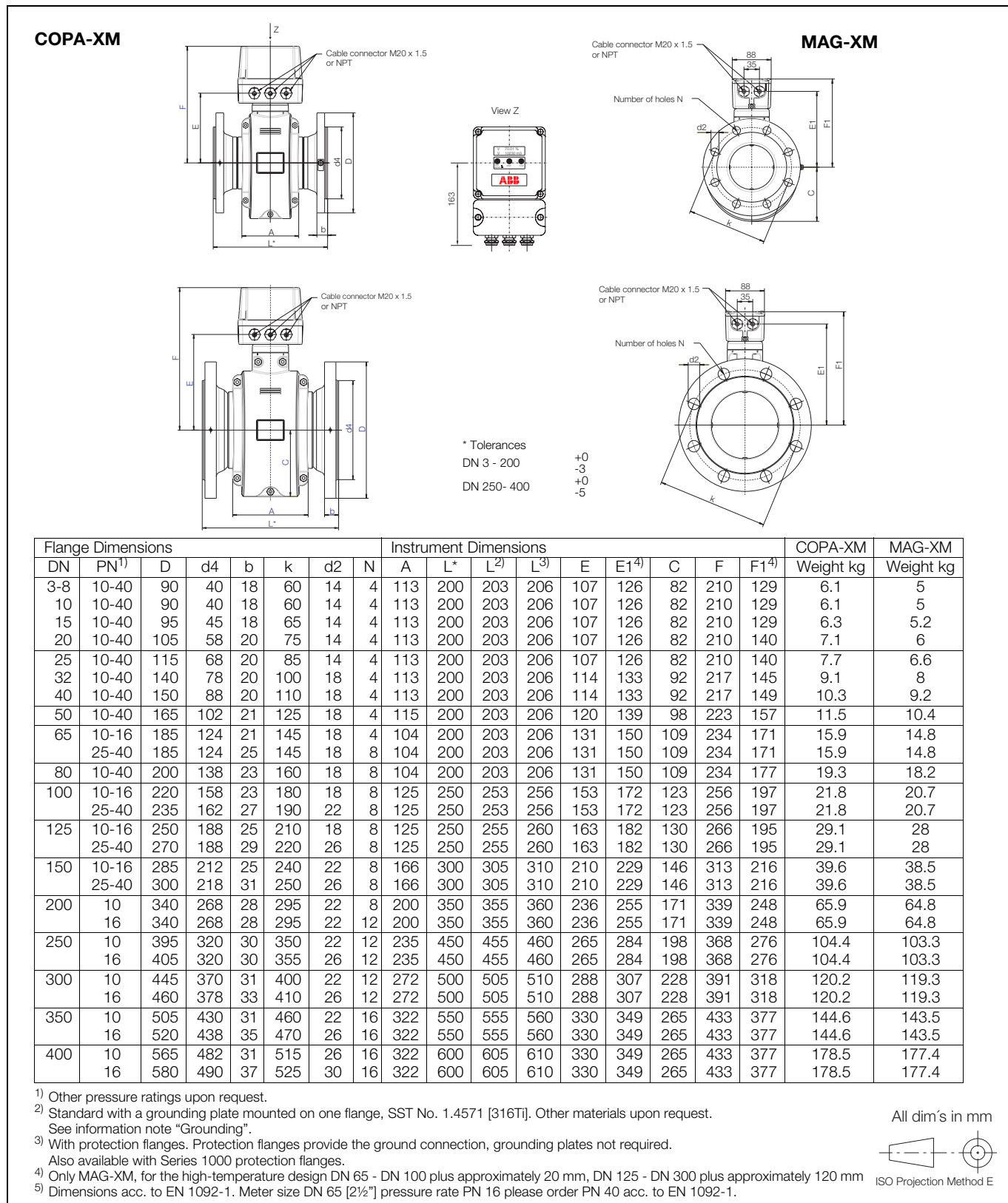

Fig. 17: Flowmeter Primaries DN 3 to DN 400, DIN/EN 1092-1 Flanges

**Dimension Drawings Flowmeter Primaries 1/10" to 16" [DN 3 to DN 400], ASME B16.5 Flanges
Models DM43F and DM41F**

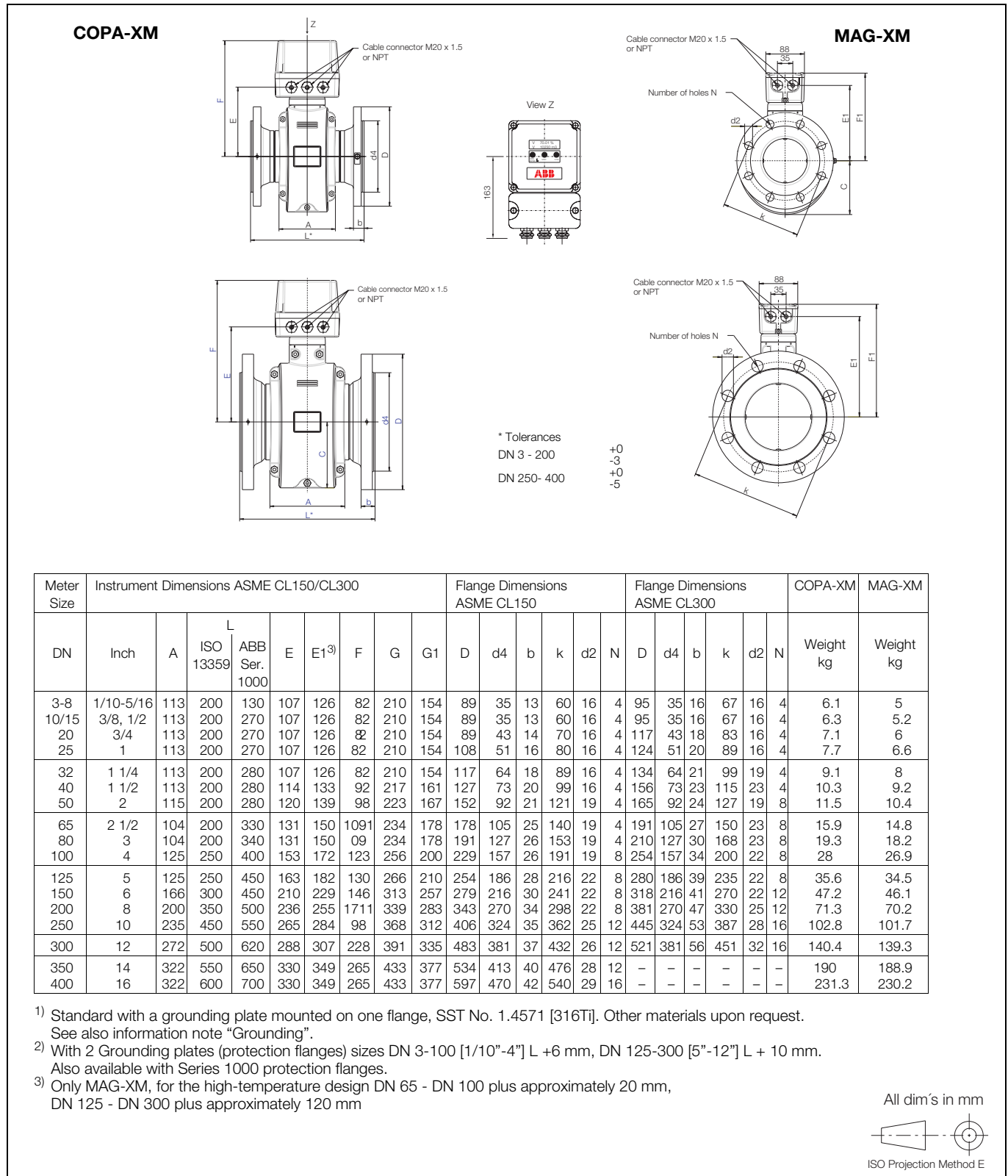

Fig. 18: Flowmeter Primaries 1/10" to 16" [DN 3 to DN 400], ASME B16.5 Flanges

Dimension Drawings Flowmeter Primaries DN 500 - DN 1000 [20" - 40"], DIN/EN1092-1⁵⁾ Flanges Models DM43F and DM41F

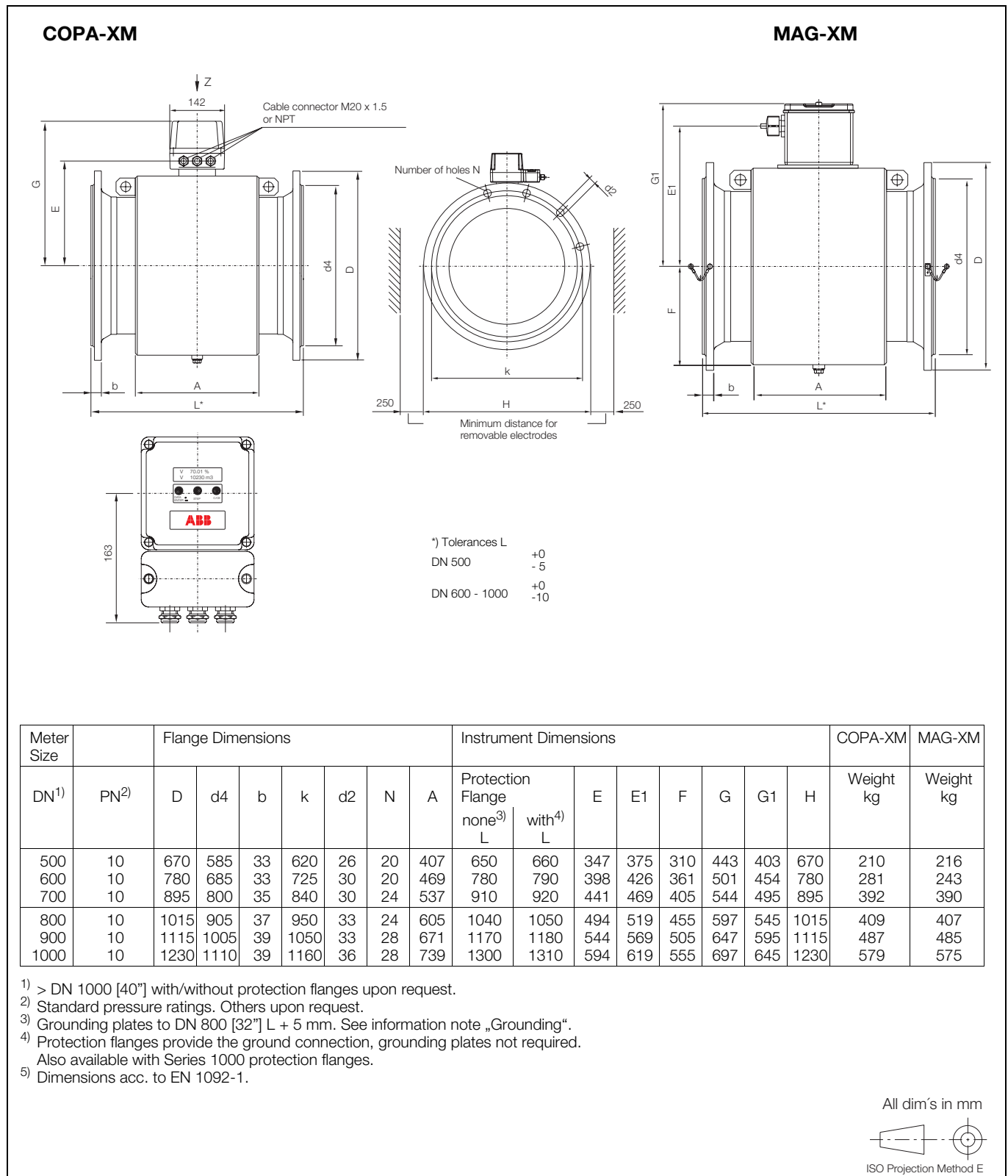

Fig. 19: Flowmeter Primaries DN 500 to DN 1000 [20" to 40"], DIN/EN1092-1 Flanges

Dimension Drawings Flowmeter Primaries 20"- 40" [DN 500 - DN 1000], ASME B16.5/B16.47 Flanges Models DM43F and DM41F

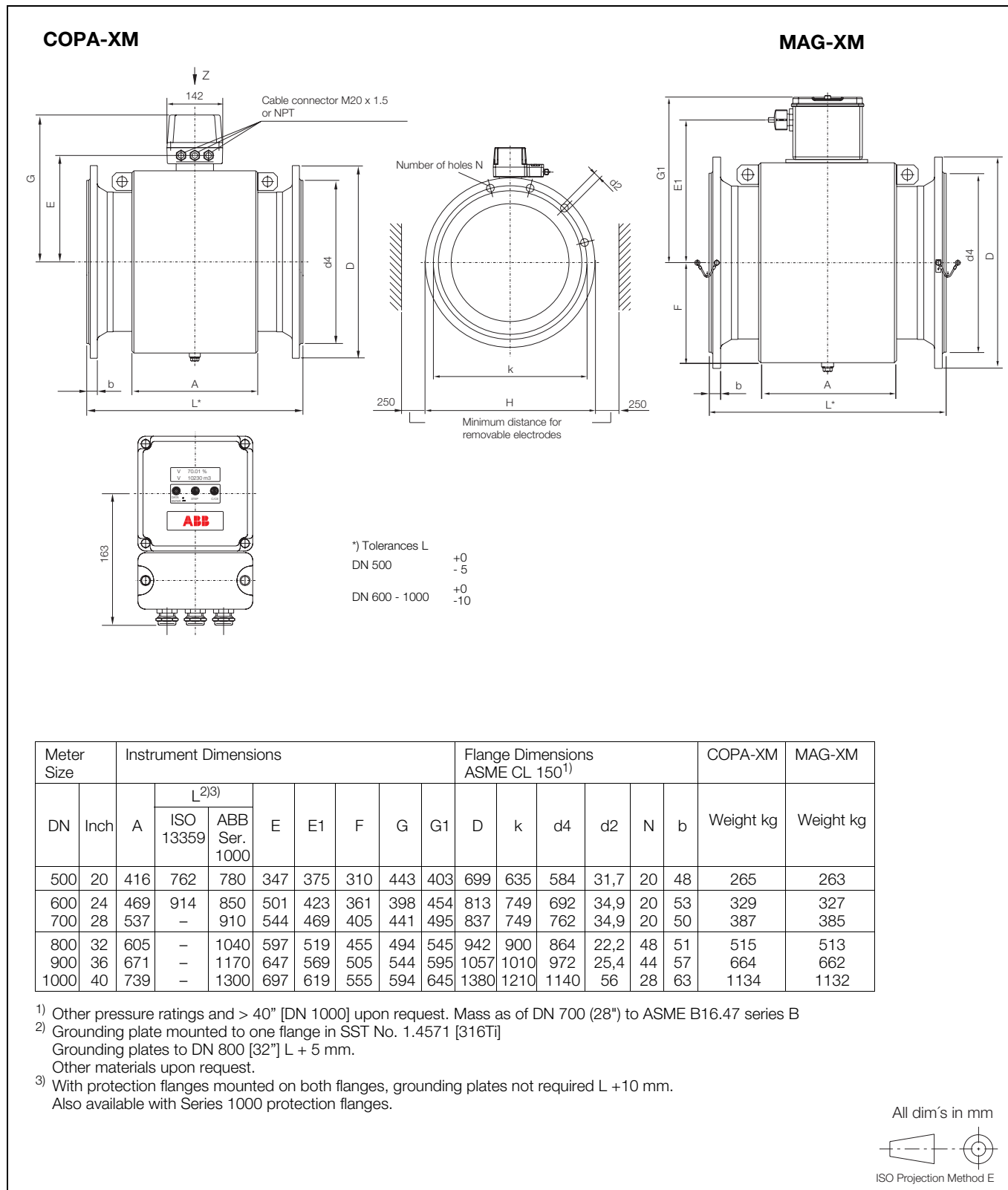

Fig. 20: Flowmeter Primaries 20" to 40" [DN 500 to DN 1000], ASME B16.5/B16.47 Flanges

Ordering Information Flanged Meters, Models DM43F and DM41F

In addition to the Ordering Number please include the following information: fluid, fluid temperature, operating pressure, flow range, pipeline type (grounding plate, grounding electrode)¹⁾

COPA-XM				MAG-XM			
Ordering Number				Ordering Number			
Conductivity ≥ 5 μS/cm		DM43F		DM41F			
Liner Material				Liner Material			
Hard rubber (DN 15 to DN 2000) [1½" to 80"]KTW approval		H				H	
Soft rubber (DN 50 to DN 2000) [2" to 80"]		S				S	
PTFE (DN 10 to DN 600) [3/8" to 24"]		T				T	
PFA (DN 3 to DN 8) [1/10" to 5/16"]		P				P	
Others		Z				Z	
Meter Size				Meter Size			
DN 3 1/10"		03				03	
DN 4 5/32"		04				04	
DN 6 1/4"		06				06	
DN 8 5/16"		08				08	
DN 10 3/8"		10				10	
DN 15 1/2"		15				15	
DN 20 3/4"		20				20	
DN 25 1"		25				25	
DN 32 1¼"		32				32	
DN 40 1½"		40				40	
DN 50 2"		50				50	
DN 65 2½" ³⁾		65				65	
DN 80 3"		80				80	
DN 100 4"		1H				1H	
DN 125 5"		1Q				1Q	
DN 150 6"		1F				1F	
DN 200 8"		2H				2H	
DN 250 10"		2F				2F	
DN 300 12"		3H				3H	
DN 350 14"		3F				3F	
DN 400 16"		4H				4H	
DN 500 20"		5H				5H	
DN 600 24"		6H				6H	
DN 700 28"		7H				7H	
DN 800 32"		8H				8H	
DN 900 36"		9H				9H	
DN 1000 40"		1T				1T	
DN 1200 48"		12				12	
DN 1400 54"		14				14	
DN 1600 64"		16				16	
DN 1800 72"		18				18	
DN 2000 80"		2T				2T	
Others		99				99	
Measuring electrode material²⁾/ Grounding electrode material				Measuring electrode material²⁾/ Grounding electrode material			
SST No. 1.4571 (316 Ti) / none			S				S
Hastelloy C-4 (2.4610) / none			H				H
Hastelloy B-3 (2.4600) / none			B				B
Titanium / none			M				M
Tantalum / none			T				T
SST No. 1.4539 (904L) / none (Food Ind. Application)			F				F
Platinum-Iridium / none			P				P
SST No. 1.4571 (316 Ti) / with			E				E
Hastelloy C-4 (2.4610) / with			O				O
Hastelloy B-3 (2.4600) / with			N				N
Titanium / with			I				I
Tantalum / with			Q				Q
SST No. 1.4539 904L) / with (Food Ind. Application)			R				R
Platinum-Iridium / with			G				G
Pressure Rating³⁾				Pressure Rating³⁾			
DIN PN 10 ISO laid length			C				C
DIN PN 16 ISO laid length			D				D
DIN PN 25 ISO laid length			E				E
DIN PN 40 ISO laid length			F				F
Others			Z				Z
JIS K10 ≤ DN 100			K				K
ASME CL150 (laid length Serie 1000, except PFA)			P				P
ASME CL300 (laid length Serie 1000, except PFA)			Q				Q
ASME CL150 ISO laid length			R				R
ASME CL300 ISO laid length			S				S
Others			Z				Z

Continued on next page

¹⁾ If a grounding plate is required (see Ordering No.). The grounding plate is made of SST No. 1.4571 [316 Ti]. Others upon request.

²⁾ From DN 125 [5"] a grounding surface is integrated in the hard/soft rubber liners, standard. Grounding electrodes available from DN3-300 [1/10"-12"].

³⁾ Dimensions acc. to DIN 2501/EN1092-1 or ASME B16.5 or JIS B2210-10K. Meter size DN 65 [2½"] pressure rating PN 16 please order PN 40 acc. to EN1092-1.

Note regarding 3A conformity: If this option is required model DM21 must be ordered.

Continuation Ordering Information

COPA-XM										MAG-XM									
Ordering Number										Ordering Number									
DM43F										DM41F									
Material of process connection																			
Steel (standard from DN 20 [¾"])										1									
SST No. 1.4571 (std. for DN 3-15 [1/10"-1/2"]). Option from DN 20 [¾"])										3									
Others upon request										9									
Accessories																			
None										A									
Protection plates SST No. 1.4571 (mounted on both flanges)										D									
Grounding plate SST No. 1.4571 (mounted on both flanges)										F									
Protection plates SST No. 1.4571 (mounted on both flanges) ¹⁾										D									
Temperature Range																			
Standard (see Specifications Liner Materials) ≤ 130 °C										S									
High Temperature Design ≤ 180 °C (only MAG-XM)										H									
Certificates																			
Standard, none										A									
Material Certificate per EN 10204 3.1 and Pressure Test per AD-2000										D									
Inspection Certificate per EN 10204 3.1										F									
Pressure Test per AD-2000										G									
Calibration Certificates																			
None										A									
Certified, Cold Water/Waste Water										B									
Certified, Liquids other than Water										C									
Type of Protection																			
IP 67										2									
IP 67 with NPT threads (only MAG-XM)										4									
IP 67 with PF threads (only MAG-XM)										5									
IP 68 (only MAG-XM)										7									
IP 68 (cables fitted and potted) (only MAG-XM)										8									
Supply Power																			
230 V 50/60 Hz										B									
115 V/ 120 V 50/60 Hz										C									
24 V 50/60 Hz										F									
24 V DC										H									
Display																			
With lighted display standard										D									
Contact In-/Output																			
Opto coupler										0									
Relay										1									
In-/Output Options none/with communication																			
Current output, pulse output active										1									
Current output, pulse output passive										3									
Current output, pulse output passive, HART-Protocol										4									
Current output, pulse output active, HART-Protocol										5									
Current output, RS485 (ASCII-Protocol)										6									
Current output, PROFIBUS DP										7									
Current output, PROFIBUS DP (with M12 plug)										9									
Operation of data entry																			
Standard with 3 Keys and Magnet Stick										B									
(Enter data without removing the housing cover)																			

Ordering Information for converter
see page 38

¹⁾ Only for installation length series 1000 and ASME or DIN flanges
Installation length ≤ DN 80 = L + 20 mm; as of DN 100 = L + 25 mm

Additional ordering information can be provided in writing.

Name Plate

- German
- English
- French

Electrode Design

Standard
Conical head (from DN 10 [3/8"] material SST No. 1.4539 [904L]
e.g. for high grease content fluids)

Information:

Please indicate in writing if a ± 0.2 % of rate calibration is required.

Dimension Drawings Stn. Stl. Flowmeter Primaries Models DM23F and DM21F, DN 3-40 [1/10"-1 1/2"] Flanged

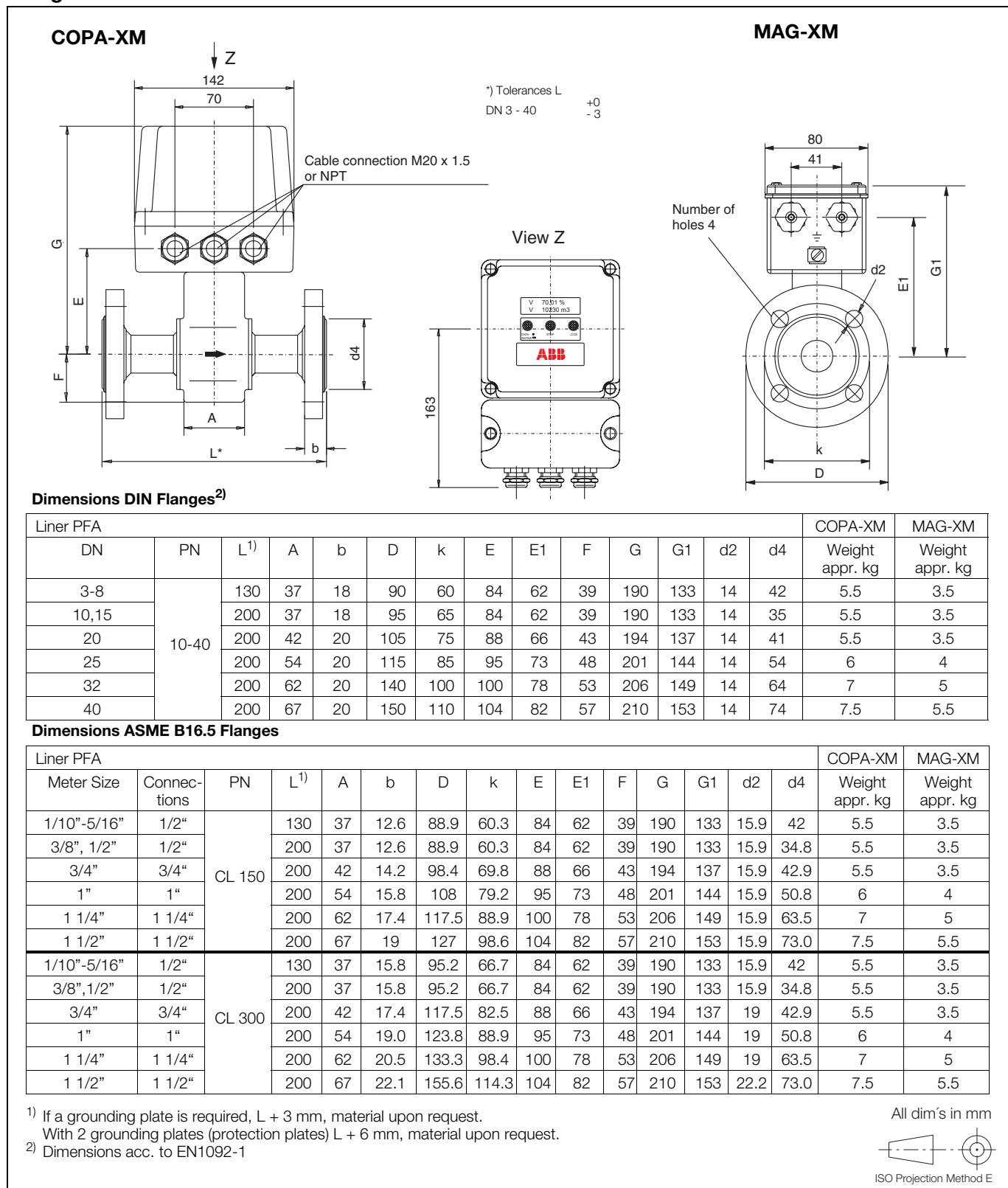

Fig. 21: Flowmeter Primaries DN 3 to DN 40 [1/10" to 1-1/2"]

Dimension Drawings Stn. Stl. Flowmeter Primaries Models DM23F and DM21F, DN 50-100 [2"-4"] Flanged

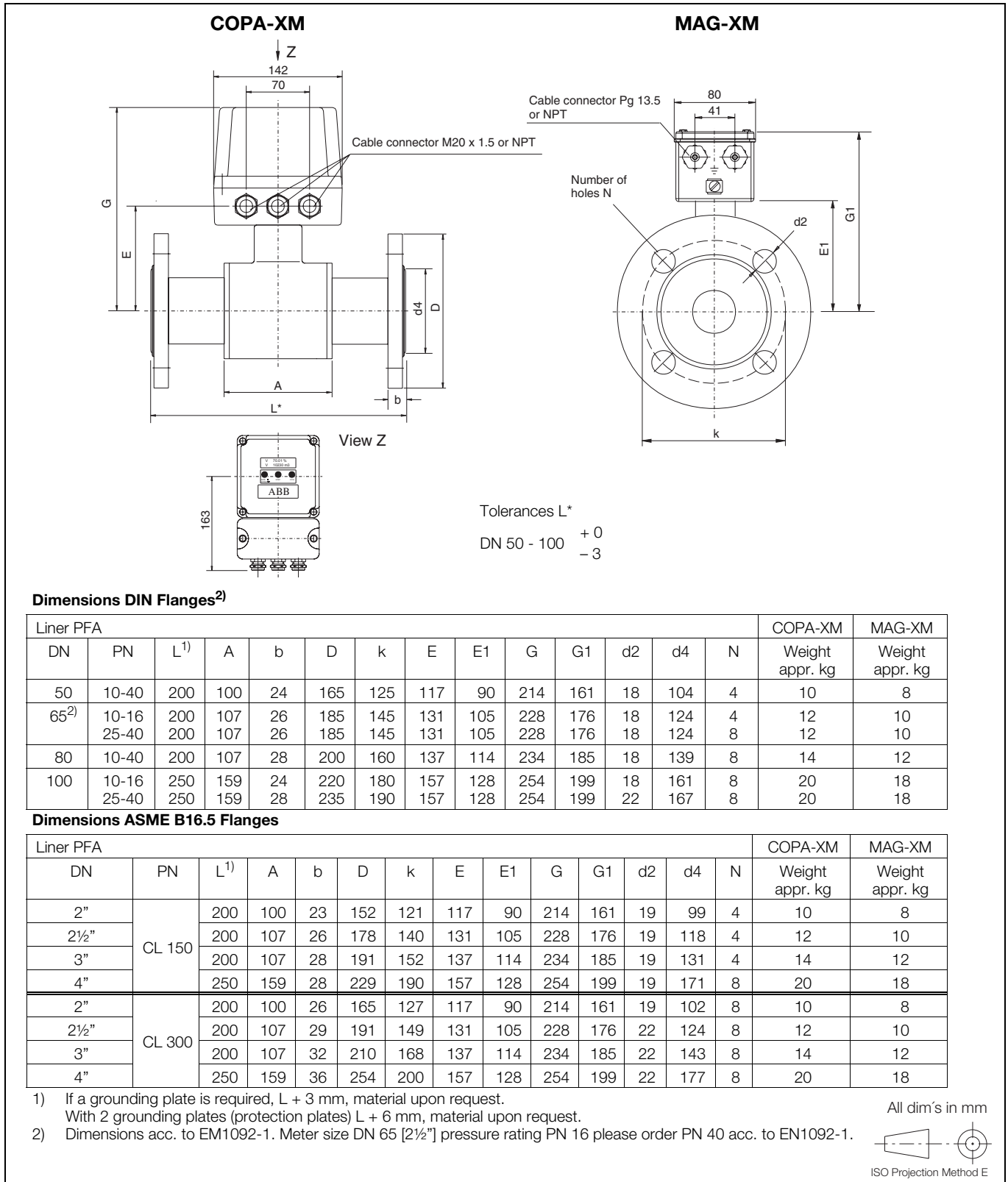

Fig. 22: Flowmeter Primaries DN 50 to DN 100 [2" to 4"]

Ordering Information Stn. Stl. Flowmeter Primaries Flanged DN 3 to DN 100 [1/10" to 4"]

In addition to the Ordering Number please include the following information: fluid, fluid temperature, operating pressure, flow range, pipeline type (grounding plate)¹⁾

COPA-XM										MAG-XM									
Ordering Number										Ordering Number									
Conductivity ≥ 5 μS/cm					DM23F					DM21F									
Liner Material: PFA					P					P									
Meter Size										Meter Size									
DN	3	1/10"							03	DN	3	1/10"							03
DN	4	5/32"							04	DN	4	5/32"							04
DN	6	1/4"							06	DN	6	1/4"							06
DN	8	5/16"							08	DN	8	5/16"							08
DN	10	3/8"							10	DN	10	3/8"							10
DN	15	1/2"							15	DN	15	1/2"							15
DN	20	3/4"							20	DN	20	3/4"							20
DN	25	1"							25	DN	25	1"							25
DN	32	1-1/4"							32	DN	32	1-1/4"							32
DN	40	1-1/2"							40	DN	40	1-1/2"							40
DN	50	2"							50	DN	50	2"							50
DN	65	2-1/2" ²⁾							65	DN	65	2-1/2" ²⁾							65
DN	80	3"							80	DN	80	3"							80
DN	100	4"							1H	DN	100	4"							1H
Measuring Electrode / Grounding Electrode Material										Measuring Electrode / Grounding Electrode Material									
SST No. 1.4571 (316 Ti) / none					S					S					S				
Hastelloy C-4 (2.4610) / none					H					H					S				
Hastelloy B-3 (2.4600) / none					B					B					S				
Titanium / none					M					M					S				
Tantalum / none					T					T					S				
SST No. 1.4539 ³⁾ (904L) / none (Food Ind. Application)					F					F					S				
Platinum-Iridium / none					P					P					S				
Others					Z					Z					S				
SST No. 1.4571 [316Ti] / with					E					E					S				
Hastelloy C-4 (2.4610) / with					O					O					S				
Hastelloy B-3 (2.4600) / with					N					N					S				
Titanium / with					I					I					S				
Tantalum / with					Q					Q					S				
SST No. 1.4539 ³⁾ (904L) / with (Food Ind. applications)					R					R					S				
Platinum-Iridium / with					G					G					S				
Others					Z					Z					S				
Pressure Rating²⁾ (ISO laid length)										Pressure Rating²⁾ (ISO laid length)									
PN 10					C					C					C				
PN 16 standard DN 100 [4"]					D					D					C				
PN 25					E					E					C				
PN 40 standard DN 3- 80 [1/10"- 3"]					F					F					C				
JIS K10					K					K					K				
ASME CL 150					P					P					K				
ASME CL 300					Q					Q					K				
Others					Z					Z					K				
Material of process connection										Material of process connection									
SST No. 1.4571 [316Ti]					3					3					3				
Others					9					9					3				
Accessories										Accessories									
None					A					None					A				
Protection plates SST No. 1.4571 (mounted on both flanges) ¹⁾					Q					Protection plate ¹⁾					Q				
Grounding plate SST No. 1.4571 (mounted on one flange) ¹⁾					R					Grounding plate ¹⁾					R				
Temperature Range										Temperature Range									
Standard design ≤ 130 °C					S					≤ 130 °C					S				

Continued on next page

¹⁾ Protection plates (2 grounding plates) mounted on both flanges and grounding plate mounted on one flange, material SS No. 1.4571[316Ti]. Others upon request.

²⁾ Dimensions acc. to DIN 2501/EN1092-1 or ASME B16.5 or JIS B2210-10K. Meter size DN 65 [2½"] pressure rate PN 16 please order PN 40 acc. to EN1092-1.

Note regarding 3A conformity:

If this option is required model DM21 must be ordered.

Continuation Ordering Information

COPA-XM											MAG-XM										
Ordering Number											DM21F										
Certificates																					
Standard, none											A										
Material Certificate per EN 10204 3.1 and Pressure Test per AD-2000											D										
Inspection Certificate per EN 10204 3.1											F										
Pressure Test per AD-2000											G										
Calibration Certificates																					
None											A										
Certified, Cold Water/Waste Water											B										
Certified, Liquids other than Water											C										
Type of Protection																					
IP 67											2										
IP 67 with NPT-threads (only MAG-XM)																					
IP 67 with PF-threads (only MAG-XM)																					
IP 68 (only MAG-XM)																					
IP 68 (cables fitted and potted) (only MAG-XM)																					
Supply Power																					
230 V, 50/60 Hz											B										
115 V/120 V, 50/60 Hz											C										
24 V, 50/60 Hz											F										
24 V DC											H										
Display																					
With lighted display standard											D										
Contact In-/Output																					
Optocoupler											0										
Relay											1										
In-/Output Options																					
Current output, pulse output active											1										
Current output, pulse output passive											3										
Current output, pulse output passive, HART-Protocol											4										
Current output, pulse output active, HART-Protocol											5										
Current output, RS485 (ASCII-Protocol)											6										
Current output, PROFIBUS DP											7										
Current output, PROFIBUS DP (with M12 plug)											9										
Operation of data entry																					
Standard with 3 keys and Magnetic Stick											B										
(Enter data without removing the housing cover)																					

Additional ordering information can be provided in writing:

Name Plate

- German
- English
- French

Electrode Design

- Standard
- Conical head (from DN 10 [3/8"] material SST No. 1.4539 e.g. for high grease content fluids).

Information:

Please indicate in writing if a ± 0.2 % of rate calibration is required.

Specifications Stn. Stl. Flowmeter Primaries, Mod. DM21_ or DM23_, DN 1 to DN 100 [1/25" to 4"]
Overview, Series 2000 Versions

Model		DM21_/DM23_										DM21/23W	PED
Meter Size	Process Conn's	1/8" - Sanitary	External Threads	Tri-Clamp DIN 32676	Tri-Clamp ASME BPE	Weld Stubs DIN 11850	Weld Stubs DIN 2463	Weld Stubs ISO 1127	Weld Stubs ISO 2037	Weld Stubs SMS	Food Ind. Fittings DIN 11851	Wafer Design	SEP Art. 3, Par. 3
		DN 1	1/25"	X									
DN 1.5	1/16"	X											
DN 2	3/32"	X											
DN 3	1/10"		X	X	X	X	X	X	X		X	X	
DN 4	4/32"		X	X	X	X	X	X	X		X	X	
DN 6	1/4"		X	X	X	X	X	X	X		X	X	
DN 8	5/16"		X	X	X	X	X	X	X		X	X	
DN 10	3/8"		X	X	X	X	X	X	X		X	X	
DN 15	1/2"		X	X	X	X	X	X	X		X	X	
DN 20	3/4"		X	X	X	X	X	X	X		X	X	
DN 25	1"		X	X	X	X	X	X	X	X	X	X	
DN 32	1-1/4"			X		X	X	X	X		X	X	Compliance Evaluation per Category III Module B1 + D, Fluid Group 1
DN 40	1-11/2"			X	X	X	X	X	X	X	X	X	
DN 50	2"			X	X	X	X	X	X	X	X	X	
DN 65	2-1/2"			X	X	X	X	X	X	X	X	X	
DN 80	3"			X	X	X	X	X	X	X	X	X	
DN 100	4"			X	X	X	X	X	X	X	X	X	

X = Available

Ambient Conditions

Ambient Temperature

-25 °C to + 60 °C

Fluid Temperature

- 40 °C to + 130 °C, CIP-capable, see Temperature Diagram and max. allowable cleaning temperatures.
 Maximum Allowable Ambient Temperature as a Function of the Fluid Temperature for SST Process Connections and Wafer Designs.

Temperature Diagram (Model DM21_)

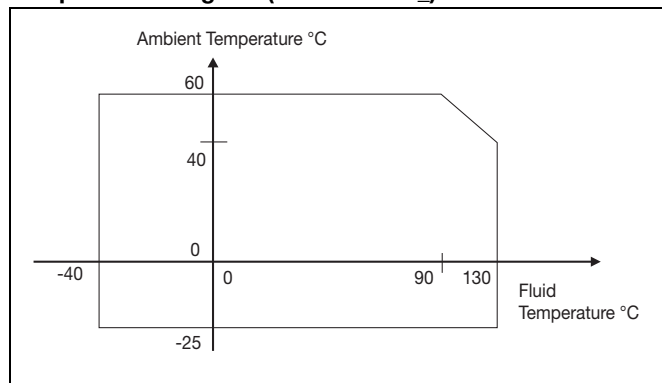

Fig. 23: Temperature Diagram (Model DM21_)

Temperature Diagram (Model DM23_)

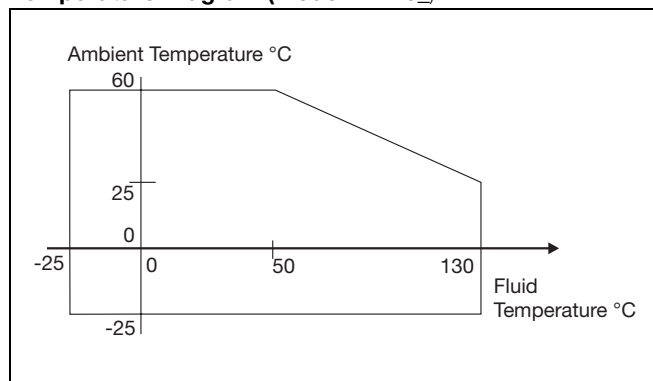

Fig. 24: Temperature Diagram (Model DM23_)

Fluid Temperature DN 1-2

-10 °C to +120 °C, CIP-capable to max. 120 °C

Storage Temperature

-25 °C to +70 °C

Minimum Allowable Absolute Pressure

Liner	Meter Size DN	Inch	P _{Operate} mbar abs	at	T _{Operate} °C
PFA	3 - 100	1/10 - 4	0	≤	130
PEEK/Torlon	1 - 2	1/25 - 1/12	0	≤	120

Specifications Flowmeter Primary

Maximum Allowable Fluid Temperature and Pressure

Process Connections Liner PFA	Meter Size		P _{Operate} at T _{Operate}	
	DN	Inch	bar	°C
Wafer design	3 - 50	1/10 - 2	40	≤ 130
	65 - 100	2½ - 4	16	≤ 130
Weld stubs	3 - 40	1/10 - 1½	40	≤ 130
	50, 80	2, 3	16	≤ 130
	65, 100	2½, 4	10	≤ 130
Food Ind. fittings DIN 11851	3 - 40	1/10 - 1½	40	≤ 130
	50, 80	2, 3	16	≤ 130
	65, 100	2½, 4	10	≤ 130
Tri-Clamp DIN 32676	3 - 50	1/10 - 2	16	≤ 121
	65 - 100	2½ - 4	10	≤ 121
Tri-Clamp ASME BPE	3 - 100	1/10 - 4	10	≤ 130
External threads ISO 228	3 - 25	1/10 - 1	16	≤ 130
1/8"-Sanitary connectors	1 - 2	1/25 - 1/12	10	≤ 120

Protection Class

- IP 67 Standard
- IP 68 (only MAG-XM DM21 possible)

Pipeline vibration following EN 60068-2-6

The following applies to compact devices (COPA):

- In the range of 10-55 Hz, max. deflection 0.15 mm
- In the range of 55-150Hz, max. acceleration 2 g

The following applies to devices with a separate measurement transmitter:

- In the range of 10-55 Hz, max. deflection 0.15 mm

Maximum Allowable Cleaning Temperatures

CIP-Cleaning	Liner	T _{max} °C	T _{max} Minutes	T _{Umg} °C
Steam cleaning	PFA/PEEK	150	60	25
Liquid cleaning	PFA/PEEK/Torlon	140	60	25

If the ambient temperature >25 °C, the difference must be subtracted from the max. cleaning temperature. T_{max} - Δ °C, Δ °C = (T_{Amb.} - 25 °C).

Maximum Allowable Temperature Shock

Liner	Temp.-Shock max. Temp.-Diff. °C	Temp.-Gradient °C/min
PFA, PEEK, Torlon	any	any

Materials, Flowmeter Primary

Liner Material	Electrode Material		Electrode Design	
	Standard	Others	Standard	Others
PFA, PEEK, Torlon	Hast.-C4 (2.4610) (1.4539 for Food Ind. fittings & Tri-Clamp)	Hast.-B3 (2.4600) SST1.4539[316Ti] SST 1.4571 Titanium, Platinum-Iridium	Nail head	Conical head (≥ DN 10 [3/8"] SST No. 1.4539)

Process Conn. Material	Standard	Option
Wafer design	none	
Weld stubs	SST No. 1.4404 [316L]	upon request
Food Ind. fitting	SST No. 1.4404 [316L]	upon request
Tri-Clamp	SST No. 1.4404 [316L]	upon request
External threads	SST No. 1.4404 [316L]	upon request
1/8"-Sanitary connector	SST No. 1.4571 [316Ti]	POM, Brass, PVC
Connection Box COPA-XM	Cast Alum., painted, paint coat Lower section: dark gray, RAL 7012 Cover: RAL 9002	
MAG-XM	SST	-
Meter tube	SST No. 1.4301 [304]	-
Cable connector	Polyamide	PVDF
Flowmeter primary housing	Deep drawn housing SST No. 1.4301[304]	

Process Conn. Design	Gasket Material
Wafer design	None
Weld stubs, flanged, Food Ind. fitting Tri-Clamp External threads	EPDM (Ethylene-Propylene) std. for FDA-Approval (CIP) capable, no oil or grease) Silicone with FDA-Approval (Option, resistant to oils and grease)
Flat housing gasket	Silicone (resistant to oils and grease)

Material load (variable process connections)

Process conn. Liner PFA	Meter Size	PS _{max} [bar]	TS _{min}	TS _{max}
Wafer design	DN3-50 (1/10...2")	40	-25 °C (-13 °F)	130 °C (266 °F)
	DN65-100 (2½...4")	16	-25 °C (-13 °F)	130 °C (266 °F)
Weld stubs	DN3-40 (1/10...1½")	40	-25 °C (-13 °F)	130 °C (266 °F)
	DN50, DN80 (2", 3")	16	-25 °C (-13 °F)	130 °C (266 °F)
	DN65, DN100 (2½", 4")	10	-25 °C (-13 °F)	130 °C (266 °F)
Food Ind. fittings DIN 11851	DN3-40 (1/10...1½")	40	-25 °C (-13 °F)	130 °C (266 °F)
	DN50, DN80 (2", 3")	16	-25 °C (-13 °F)	130 °C (266 °F)
	DN65, DN100 (2½", 4")	10	-25 °C (-13 °F)	130 °C (266 °F)
Tri-Clamp DIN 32676	DN3-50 (1/10...2")	16	-25 °C (-13 °F)	121 °C (250 °F)
	DN65-100 (2½...4")	10	-25 °C (-13 °F)	121 °C (250 °F)
Tri-Clamp ASME BPE	DN3-100 (1/10...4")	10	-25 °C (-13 °F)	130 °C (266 °F)
External threads ISO 228	DN3-25 (1/10...1")	16	-25 °C (-13 °F)	130 °C (266 °F)
1/8" Sanitary connectors	DN1-2 (1/25...1/12")	10	-25 °C (-13 °F)	120 °C (248 °F)

Liners: PFA Wafer Design



Abb. 25: PFA Zwischenflansch, Modell DM2_W

JIS B2210-10K Wafer Design

Meter Size DN	Material	PN	TS [°C]	PS [bar]
32-300	W.-Nr. 1.4404 W.-Nr. 1.4435 W.-Nr. 1.4301	10	-40 to +130	10

Dimension Drawings Stn. Stl. Flowmeter Primaries, Wafer Design, DN3-100 [1/10"-4"], Mod. DM21W and DM23W

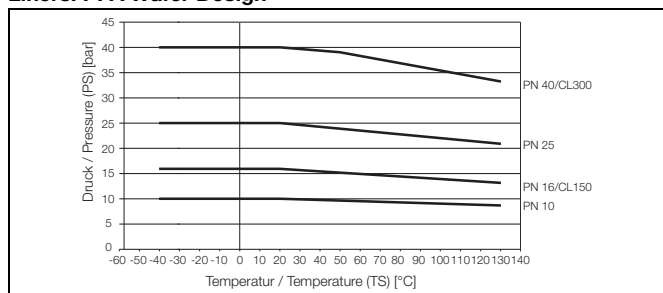
**DN 3 – DN 40
1/10" – 1 1/2"**

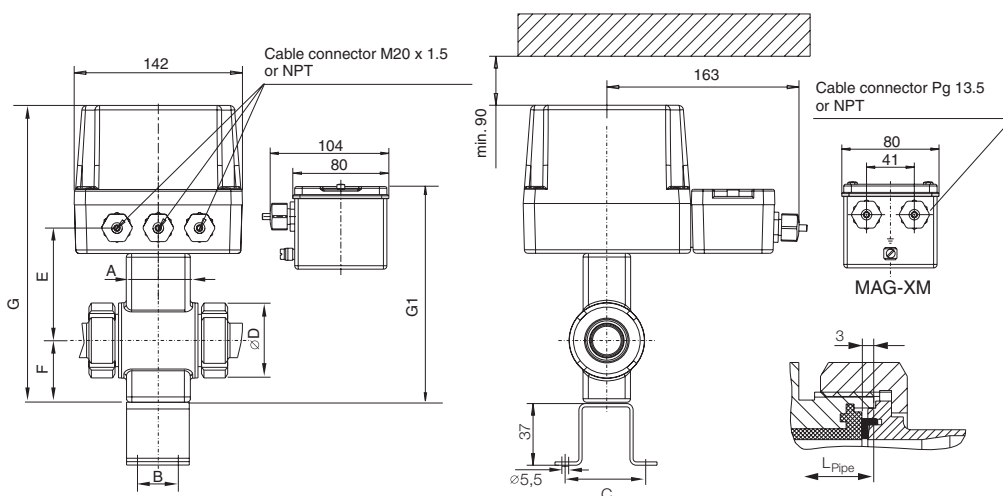

**DN 50 – DN 100
2" – 4"**

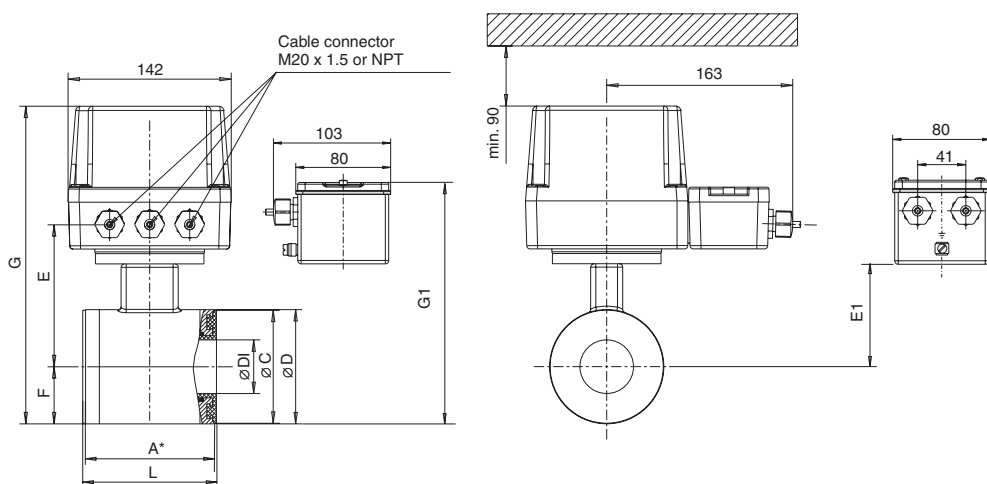

Size DN	Inch	PN	L ¹⁾	A*	A	C	ØC	ØDi	ØD	E	E1	F	G	G1 MAG-XM	J	COPA-XM appr. kg	MAG-XM appr. kg
3	1/10	10-40 CL150 JIS	68	64	37	50	42	6	45	96	62	39	239	149	28	3.5	1.5
4	5/32																
6	1/4																
8	5/16																
10	3/8																
15	1/2							8									
20	3/4		78	74	42	50	50	20	54	100	66	43	247	182	32	4	2.0
25	1		90	86	54	70	59	25	63	107	73	48	259	194	32	4	2.0
32	1 1/4		98	94	62	70	69	32	73	112	78	53	269	204	32	4.5	2.5
40	1 1/2		103	99	67	70	77	40	82	116	82	57	277	212	32	5	3.0
50	2		117	112	-	110	95	47	100	124	90	50	278	213	-	6	4.0
65	2 1/2	10-16 CL150 JIS	103	99	-	110	111	62	116	138	105	58	300	235	-	6.5	4.5
80	3																
100	4																
			133	129	-	110	155	96	160	164	128	80	348	279	-	10.5	8.5

¹⁾ Laid lengths with 2 grounding plates L + 3 mm

Mounting Option Bracket
 With mounting bracket size DN 3 - 40 [1/10" - 1 1/2"] complete height +37 mm. DN 50 - 100 [2" - 4"] complete height +10.5 mm.
 Mounting accessories see page 26

All dim's in mm

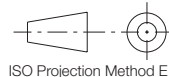
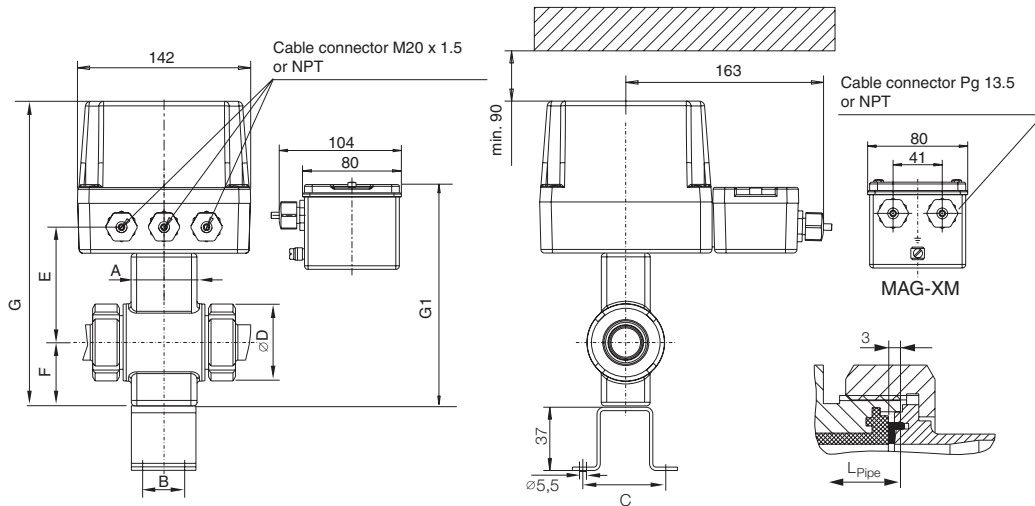

Fig. 26: Dimension Drawings, Models DM21W and DM23W, DN 3 to DN 100 [1/10" to 4"], Wafer Design

Dimension Drawings Flowmeter Primaries, Variable Process Connections, Mod. DM21_ and DM23_

DN 3 – DN 40
1/10" – 1½"



DN 50 – DN 100
2" – 4"

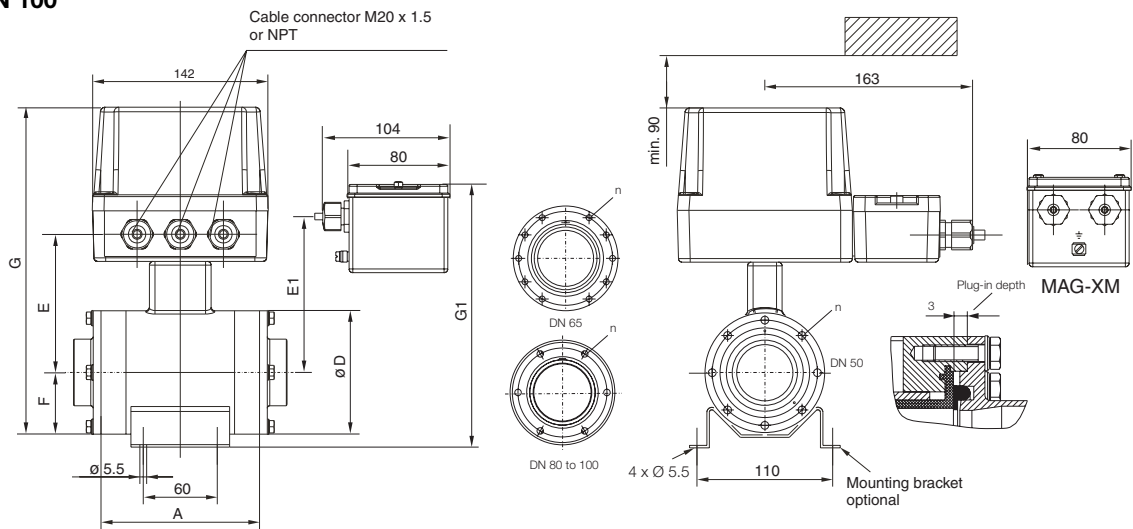

Meter Size DN	A	B	C	ØD	E	E1	F	G	G1 MAG-XM	N	L _{Pipe}	SW	COPA-XM Wgt. appr. kg ¹⁾	MAG-XM Wgt. appr. kg ¹⁾
3-10 1/10-3/8	37	28	50	-	96	62	39	239	149	-	85	46	5.0	1.5
15 1/2	37	28	50	-	96	62	39	239	149	-	85		5.0	1.5
20 3/4	42	28	50	-	100	66	43	247	182	-	90	60	5.0	2.0
25 1	54	46	70	-	107	73	48	259	194	-	105		5.5	2.0
32 1-1/4	62	46	70	-	112	78	53	269	204	-	120	75	6.0	2.5
40 1-1/2	67	46	70	-	116	82	57	277	212	-	125		6.5	3.0
50 2	128	60	110	100	124	90	50	278	213	8	-	-	8.0	4.0
65 2-1/2	114	60	110	116	138	105	58	300	234	10	-	-	8.5	4.5
80 3	114	60	110	133	144	114	66,5	314,5	252	6	-	-	10.0	6.5
100 4	144	60	110	160	164	128	80	348	279	6	-	-	12.5	9.0

Laid lengths with process connections see Page 25

¹⁾ Plus process connection weight see Page 25

Mounting Option Bracket

With mounting bracket size DN 3 - 40 [1/10" - 1½"] complete height +37 mm.

With mounting bracket size DN 50 - 100 [2" - 4"] complete height +10.5 mm.

All dim's in mm

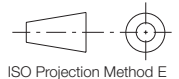

ISO Projection Method E

Fig. 27: Dimension Drawings, Models DM21 and DM23, DN 3 to DN 100 [1/10" to 4"], Basic Dimensions for all Variable Process Connections

Dimension Drawings Stn. Stl. Flowmeter Primaries, Adapters for Variable Process Connections

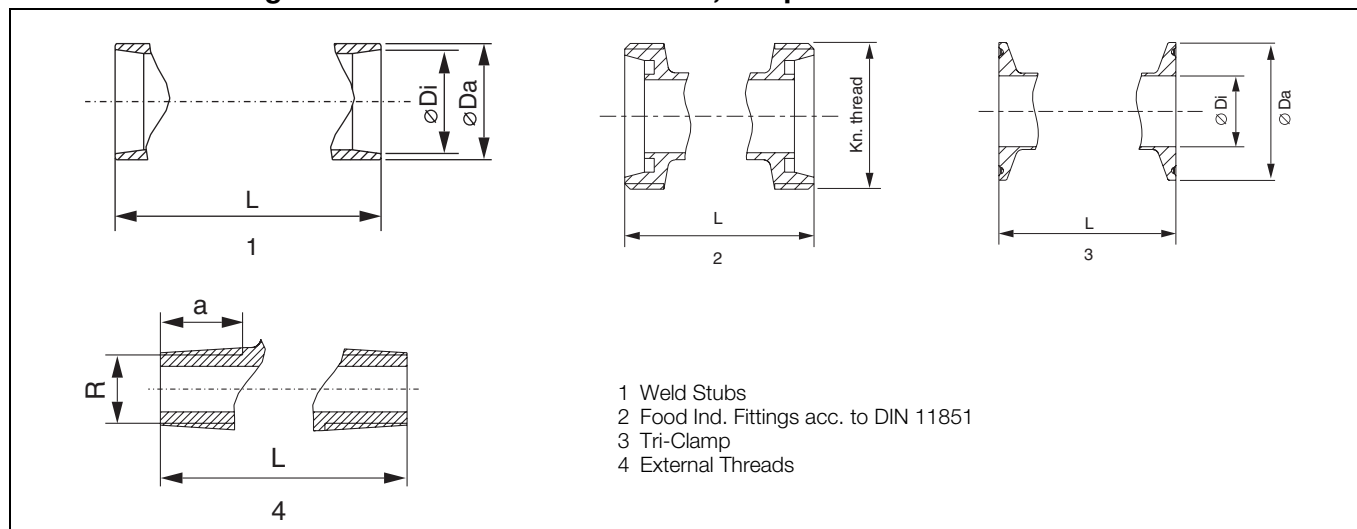

Fig. 28: Dimension Drawings, DN 3 to DN 100 [1/10" to 4"], Adapter for Variable Process Connections

Meter Size		Weld Stubs														L	Wgt./kg
		ISO 2037		DIN 11850		SMS		L	Wgt./kg	DIN 2463		ISO 1127					
DN	Inch	∅ Di	∅ Da	∅ Di	∅ Da	Series	∅ Di			∅ Da			∅ Di	∅ Da	∅ Di	∅ Da	Series
3-10	1/10-3/8	10	12	10	13	2	-	-	127	0.4	10.3	13.5	10.3	13.5	1	127	0.4
15	1/2	15.2	17.2	16	19	2	-	-	127	0.4	18.1	21.3	18.1	21.3	1	127	0.4
20	3/4	19.3	21.3	20	23	2	-	-	132	0.7	23.7	26.9	23.7	26.9	1	132	0.7
25	1	22.6	25	26	29	2	22.6	25	149	0.7	25	28	23.7	26.9	1	149	0.7
32	1-1/4	31.3	33.7	32	34	1	-	-	166	1	32	35	30.5	33.7	1	166	1
40	1-1/2	35.6	38	38	41	2	35.6	38	171	1	36.8	40	39	42.2	1	171	1
50	2	48.6	51	50	54	3	48.6	51	173	1	49	52	47.8	51	2	173	1
65	2-1/2	60.3	63.5	66	70	2	60.3	63.5	165	1.4	66	70	66	70	2	165	1.4
80	3	72.9	76.1	81	85	2	72.9	76.1	169	2	81	85	72.9	76.1	1	169	2
100	4	97.6	101.6	100	104	2	100	104	199	2.6	100	104	97.6	101.6	2	227	3

Meter Size		Food Ind. Fittings			Tri-Clamp									
		DIN 11851			DIN 32676 ¹⁾					ASME BPE				
DN	Inch	Kn. thread	L	Wgt./kg	∅ Di	∅ Da	Series	L	Wgt./kg	Tri-Clamp	∅ Di	∅ Da	L	Wgt./kg
3-10	1/10-3/8	28 x 1/8"	169	0.5	10	34	3	163	0.5	1/2"	9.4	25	143	0.5
15	1/2	34 x 1/8"	169	0.5	16	34	3	163	0.5	3/4"	15.7	25	143	0.5
20	3/4	44 x 1/6"	180	0.9	20	34	3	168	0.7	1"	22.1	50.4	143	0.7
25	1	52 x 1/6"	207	0.9	26	50,5	3	192	0.8	1"	22.1	50.4	143	1.2
32	1-1/4	58 x 1/6"	230	1.4	32	50,5	3	209	1.5	-	-	-	-	-
40	1-1/2	65 x 1/6"	237	1.4	38	50,5	3	214	1.4	1 1/2"	34.8	50.4	277	1.8
50	2	78 x 1/6"	243	1.4	50	64	3	216	1.2	2"	47.5	63.9	277	1.8
65	2-1/2	95 x 1/6"	245	2.2	66	91	1	221	1.6	2 1/2"	60.2	77.4	277	2.0
80	3	110 x 1/4"	259	3.2	81	106	1	225	2.4	3"	72.9	90.9	337	3.6
100	4	130 x 1/4"	307	4.4	100	109	1	255	3.1	4"	97.4	118.9	337	4.1

¹⁾ DN 3 - 50 acc. to series 3 / DN 65 - 100 acc. to series 1

Meter Size		External Threads ISO 228 / DIN 2999			
DN	Inch	R	a	L	Weight kg
3-10	1/10-3/8	3/8"	18	139	0.4
15	1/2	1/2"	18	139	0.4
20	3/4	3/4"	25	164	0.8
25	1	1"	25	179	0.8

Wafer accessories

Depending on the nominal width and nominal pressure, the following accessories are available (bolts, nuts, lock washers) centering elements. Seals are not included in the accessories.

Material: CrNi-Stahl

Meter Size	Nominal pressure rating	Part number
DN 3 - 10	PN 10 - 40	D614L265U03
	150 lb	D614L265U03
	300 lb	D614L265U04
DN 15	PN 10 - 40	D614L265U03
	150 lb	D614L266U05
	300 lb	D614L266U06
DN 20	PN 10 - 40	D614L267U04
	150 lb	D614L267U05
	300 lb	D614L267U06
DN 25	PN 10 - 40	D614L268U04
	150 lb	D614L268U05
	300 lb	D614L268U06
DN 32	PN 10 - 40	D614L269U04
	150 lb	D614L269U05
	300 lb	D614L269U06
DN 40	PN 10 - 40	D614L270U04
	150 lb	D614L270U05
	300 lb	D614L270U06
DN 50	PN 10 - 40	D614L296U04
	150 lb	D614L296U05
	300 lb	D614L296U06
DN 65	PN 10 - 16	D614L297U08
	150 lb	D614L297U10
DN 80	PN 10 - 40	D614L298U08
	150 lb	D614L298U09
DN 100	PN 10 - 16	D614L299U07
	150 lb	D614L299U09

Welding jig to simplify the welding for flowmeter primaries with variable process connections

This welding jig is used in place of the flowmeter primary during the welding operation and assures correct dimensions and perpendicularity of the mating surfaces as well as the sealing function.

		Diameter	Part number
	DN10 - 10	1/10" - 3/8"	D413C470U01
	DN15	1/2"	D413C471U01
	DN20	3/4"	D413C472U01
	DN25	1"	D413C473U01
	DN32	1 1/4"	D413C474U01
	DN40	1 1/2"	D413C475U01
	DN50	2"	D413C488U03
	DN65	2 1/2"	D413C461U09
	DN80	3"	D413C496U03
	DN100	4"	D413C498U03

Only the welding jig is included with the shipment (no gaskets/connection adapters)

Dimension Drawings: Stn. Stl. Flowmeter Primaries, 1/8"-Sanitary Connector, DN 1 to DN 2 [1/25" to 1/12"]

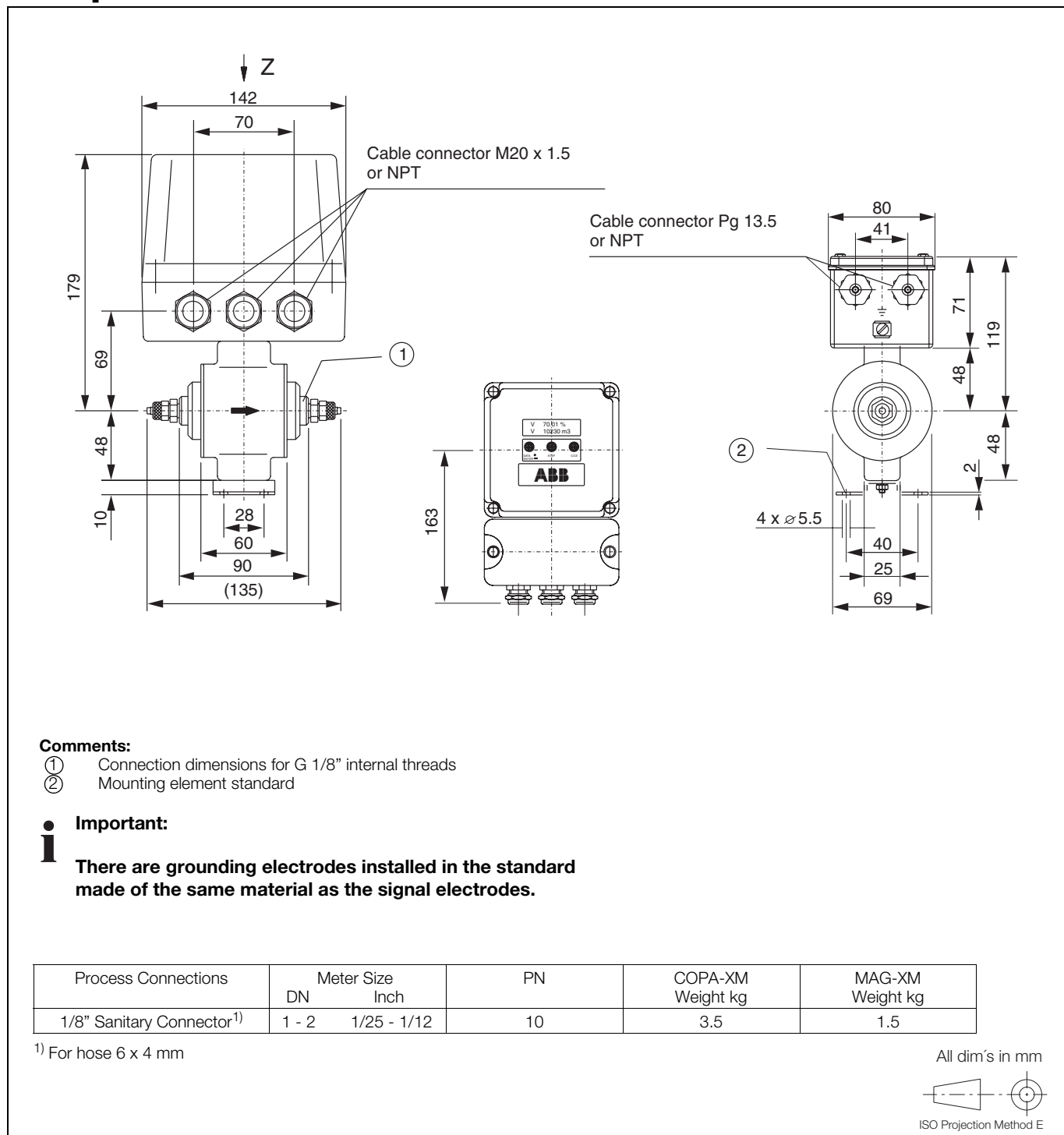

Fig. 29: Dimension Drawings: Flowmeter Primaries DN 1 to DN 2 [1/25" to 1/12"], Models DM23B and DM21B

Ordering Information Stainless Steel Flowmeter Primary

In add. to Ord. No. pl. incl. the follow. inform.: fluid, fluid temp., oper. press., flow range, pipeline type (ground. plate, ground. electr.)¹⁾

COPA-XM				MAG-XM			
Ordering Number				Ordering Number			
Conductivity $\geq 5 \mu\text{S/cm}$		DM23		DM21			
Process Connections				Process Connections			
Wafer design		W		W			
Weld stubs DIN 11850		R		R			
Weld stubs DIN 2463		Q		Q			
Weld stubs ISO 2037		P		P			
Weld stubs ISO 1127		J		J			
Weld stubs SMS DN 25-100 [1"-4"]		X		X			
Food Ind. fittings DIN 11851		S		S			
Tri-Clamp DIN 32676		T		T			
External threads ISO 228 DN 3-25		E		E			
1/8"-Sanitary connectors DN 1-2 [1/25"-1/12"]		B		B			
Tri-Clamp ASME BPE		K		K			
Others		Z		Z			
Liner Material				Liner Material			
PFA (DN 3 - 100) [1/10"-4"]		P		P			
PEEK (DN 1-2) [1/25"-1/12"]		K		K			
Torlon (DN 1- 2) [1/25"-1/12"]		N		N			
Meter Size				Meter Size			
DN 1	1/25"		01				01
DN 1.5	1/16"		1S				1S
DN 2	1/12"		02				02
DN 3	1/10"		03				03
DN 4	5/32"		04				04
DN 6	1/4"		06				06
DN 8	5/16"		08				08
DN 10	3/8"		10				10
DN 15	1/2"		15				15
DN 20	3/4"		20				20
DN 25	1"		25				25
DN 32	1-1/4"		32				32
DN 40	1-1/2"		40				40
DN 50	2"		50				50
DN 65	2-1/2"		65				65
DN 80	3"		80				80
DN 100	4"		1H				1H
Measuring Electrode/ Grounding Electrode Material²⁾				Measuring Electrode/ Grounding Electrode Material²⁾			
Hastelloy C-4 (2.4610) /none			H				H
Hastelloy B-3 (2.4600) /none			B				B
SST No. 1.4571 [316Ti] /none standard			S				S
Titanium /none			M				M
Tantalum /none			T				T
SST No. 1.4539 (904 L) /none (Food Ind. applications)			F				F
Platinum-Iridium /none			P				P
Hastelloy C-4 (2.4610) /with			O				O
Hastelloy B-3 (2.4600) /with			N				N
SST No. 1.4571 [316Ti] /with standard			E				E
Titanium /with			I				I
Tantalum /with			Q				Q
SST No. 1.4539 (904 L) /with (Food Ind. applications)			R				R
Platinum-Iridium /with			G				G
Others			Z				Z
Pressure Rating				Pressure Rating			
PN 10 Tri-Clamp DIN 32676, DN 65-100 [2½"-4"]			C				C
Tri-Clamp ASME BPE, Food Ind. Fitt., DN 65, 100 [2½"-4"]							
1/8" sanitary connector, Weld stubs DN 65, 100 [2½"-4"]							
PN 16 Tri-Clamp DIN 32676, DN 3-50 [1/10"-2"]			D				D
Food Ind. Fitting DN 50, 80 [2", 3"],							
Weld stubs DN 50, 80 [2", 3"], Wafer DN 65-100 [2½"-4"]							
PN 40 Food Ind. Fitting, (DN 3-40 [1/10"-1½"]			F				F
Weld stubs DN 3-40 [1/10"-1½"], Wafer DN 3-50 [1/10"-2"]							

Continued on next page

¹⁾ Only required for wafer design meters with insulated pipelines.

²⁾ Always specify grounding electrode material for DN 1-2 [1/25"-1/12"], standard.

Specifications Converter



Fig. 30: Plug in unit MAG-XM

Flow Range

End value can be set anywhere between 0.5 and 15 m/s

Forward/Reverse Metering

The flow direction is indicated by arrows in the display and signalled externally over a relay contact or optocoupler.

Accuracy

≤ 0.4% of rate, option 0.2% of rate

Minimum Conductivity

≥ 5 μS/cm
 (≥ 20 μS/cm for flowmeter primaries DN 1 - DN 1.5 [1/25" - 1/12"])

Reproducibility

≤ 0.1% of rate

Response Time (0-99% equiv. to 5 τ)

For a 0-99% step change ≥ 0.125 s to 0.5 s

Supply Power

115/230 V AC -15%/+10%
 24 V AC -15%/+10%
 50/60 Hz ± 6%
 24 V DC -25%/+30% ripple ≤ 1.5 Vpp

Magnetic Field Supply

Standard: 6 1/4, 7 1/2 Hz, 12 1/2, 15 Hz, 25, 30 Hz

Power

≤ 23 VA (flowmeter primary including the converter)

Ambient Temperature

-25 to +60 °C

Protection Class per EN 60529

IP 67 for field mount housing,
 IP 67 COPA-XM

Design

Field mount housing, cast light metal¹⁾

¹⁾ Paint coat 60 μm thick, lower section RAL 7012
 upper section (cover) RAL 9002.

Electrical Connections

Screw terminals, cable connectors M20 x 1.5

Weight

Approx. 3.8 kg field mount housing

Signal Cable (only MAG-XM)

The max. signal cable length between the flowmeter primary and the converter is 200 m, ≥ 200 m upon request. Each flowmeter system is shipped with a 10 m long signal cable. If a length greater than 10 m is required, see Ordering Information Converter see page 38, Footnote.

Parameter Entries

The data can be entered in 9 languages using the keypad on the converter. It is also possible to enter data externally without opening the cover using a Magnetic Stick. Data security is provided by a NV-RAM. All parameters and totalizer values are stored in an NV-RAM for a 10 year period when the supply power is turned off or interrupted without batteries.

Display

2x16-character LCD-dot matrix display with LED background lighting. The flow is totalized internally, separate for each flow direction, in one of 16 different units. The flowrate value can be display in percent or one of 45 different units.

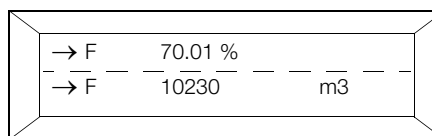

The units listed below can be selected using the arrow keys. These units are used for Range_{max}, Q_{max} forward and reverse and the flow-rate display, when a direct reading engineering unit is selected. In Multiplex operation the flowrate in %, direct reading engineering units or as a bargraph, forward and reverse totalizer values, TAG-No. or current output value can additionally be selected for display in the 1st and 2nd lines.

Unit	Second	Minute	Hour	Day
Milliliter	ml/s	ml/min	ml/h	
Liter	l/s	l/min	l/h	
Hectoliter	hl/s	hl/min	hl/h	
Megaliter		MI/min	MI/h	MI/day
Cubic meter	m ³ /s	m ³ /min	m ³ /h	
Imperial-gallon per	igps	igpm	igph	
U.S.-mill.-gall. per/d				mgd
U.S.-gall. per		gpm	gph	
Barrel Brewery	bbl/s	bbl/min	bbl/h	
Barrel Petrochemical		bls/min	bls/h	bls/day
Gram	g/s	g/min	g/h	
U.S. Ton		uton/min	uton/h	uton/day
Kilogram	kg/s	kg/min	kg/h	
Ton	t/s	t/min	t/h	
Pound	lb/s	lb/min	lb/h	
Kilo-gallon per	kgal/s	kgal/min	kgal/h	

Data Storage Module (external EEPROM)

When the flowmeter is shipped the external EEPROM is plugged into a socket on the connection board in the converter. The calibration data for the flowmeter primary and meter installation site parameters are stored in the EEPROM.

System Monitor – Alarm Output

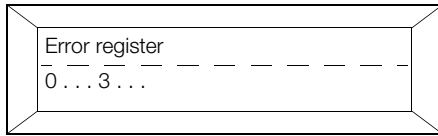

Automatic system monitoring with error diagnostics displayed together with an alarm signal over the contact output. All errors detected are stored in the error register.

Design	Optocoupler	Relay
Terminals	P1, P2	P1, P2
Function	EB, CB	96, 97
Operating voltage	$16\text{ V} \leq U_{CEH} < 30\text{ V}$ $0\text{ V} \leq U_{CEL} < 2\text{ V}$	$16\text{ V} \leq U < 30\text{ V}$
Operating current	$0\text{ mA} \leq I_{CEH} < 0.2\text{ mA}$ $2\text{ mA} \leq I_{CEL} < 15\text{ mA}$	$0\text{ mA} \leq I < 250\text{ mA}$ $P \leq 3\text{ Watt}$

The individual subassemblies can be tested using the Function Test submenu. The values for all outputs can be simulated providing the ability to perform checks during start-up.

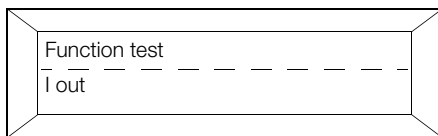

Empty Pipe Detector (available from DN 10 [3/8"] and from 20 μS/cm)

Automatic recognition of an empty pipe condition using the Empty Pipe Detector which sends a signal over the contact output and displays a message, max. signal cable length is 50 m for MAG-XM. If the empty pipe detector is turned on and the pipe empties, the current output is set to 0 % (3.6 or 4 mA for 4-20 mA) or 130 % of the current end value and the pulse totalization is stopped.

Information:

The instrument conforms to the NAMUR-Recommendations "EMC-Directive for Manufacturers and Operators of Electrical Instruments and Systems" Part 1, 5/93 and EMC-Directive 89/336/EWG (EN 50081-1, EN 50082).

Caution:

When the housing cover is open, EMC and contact protection is no longer provided.

Output Signals Standard

Isolation In-/Output

The current and pulse outputs are isolated from the input circuit and from each other.

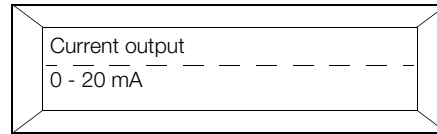

Current Output, Selectable, Terminals +/-

Range	Load Resistance
0 - 5 mA	$\leq 4000\ \Omega$
0/2 - 10 mA	$\leq 2000\ \Omega$
0/4 - 20 mA	$\leq 1000\ \Omega$

Load Curve 0/4 - 20 mA

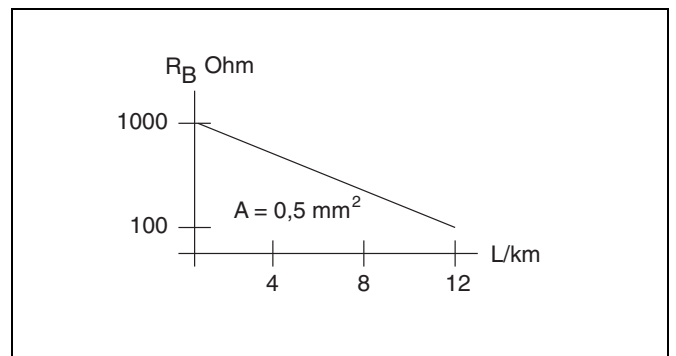

Output Characteristic

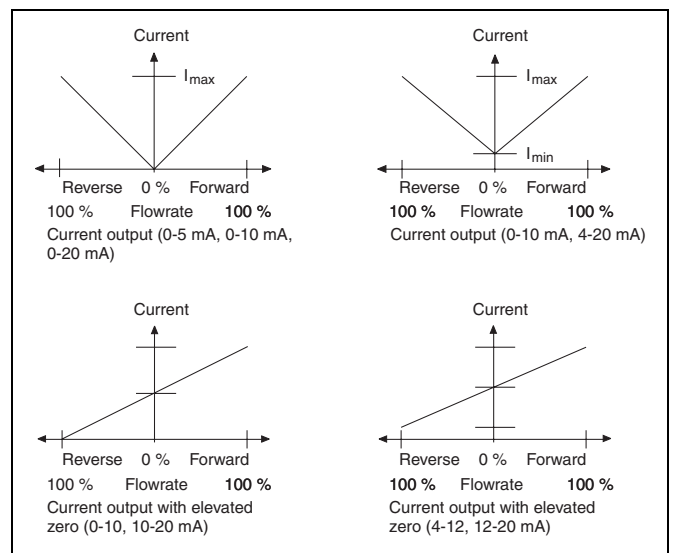

Scaled Pulse Output

The scaled pulse output is a 1-channel output with a max. frequency of 5 kHz and a pulse factor between 0.001 and 1000 for multiplying the values in the display e.g. 1 pulse/m³ x 1000. The pulse width can be set between 0.100 ms and 2000 ms. Jumpers on the connection board are used to configure the pulse output as passive or active. The output can be reconfigured whenever required.

Design	Active		Passive	
	COPA-XM	MAG-XM	COPA-XM	MAG-XM
Terminal Function	V1, V3 g2, 10	V8, V9	V1, V3 G2, 61	V8, V9
Operating voltage	16 V ≤ U ≤ 30 V DC load ≥ 150 Ohm fmax = 5 kHz		16 V ≤ U _{CEH} < 30 V DC 0 V ≤ U _{CEL} < 2 V 0 mA ≤ I _{CEH} < 0.2 mA 2 mA ≤ I _{CEL} < 250 mA fmax = 5 kHz	
Operating current and frequency	When a mechanical counter is used, it is recommended that the pulse width be set ≥ 30 ms and fmax ≤ 3 Hz		When a mechanical counter is used, it is recommended that the pulse width be set ≥ 30 ms and fmax ≤ 3 Hz	

Programmable Input

The following functions can be assigned to the contact input, active or passive, in the software

Function	Active or Passive	
	Normally open	
		
External Zero Return When the pipeline is empty all output signals can be turned off.	X	X
External Totalizer Reset The internal totalizers and any overflow counter values can be reset when the contact is activated.	X	X
Flow Range 1/2 *) External flow range selection Flow range 2 is selected when the contact is closed.	X	X
START/STOP *) Preset Counter External contact to start metering a predetermined quantity. To initiate a safety stop, activate the contact again.	X	X
Terminals	X1, U2 ¹⁾ Jumper G2 - g2	X1, G2
Operating voltage	16 V ≤ U _{CEH} < 30 V 0 V ≤ U _{CEL} < 2 V R _i = 2.0 kΩ	
Operating current	0 mA ≤ U _{CEH} < 0.2 mA 2 mA ≤ U _{CEL} < 15 mA	

1) Optional function for COPA-XM (internal 24 V DC supply)

*) The functions must first be selected in the submenu "Operating mode".

X = Function can be selected in the software

Information:

i The contact input should be actuated by closing it for more than 1s (preset counter START/STOP >350 ms but not longer than 1.5 s).

Alarm Output

Automatic system monitor including CPU failure check with error diagnostics in the display and an error signal over the passive contact output. The errors 0-9 are stored in the submenu Alarm as a check. The contact opens during an alarm condition.

Programmable Output

Contact output, passive, the following functions can be assigned to the output in the software:

Function	Normally Closed	or	Open
General alarm	X		X
Empty pipe	X		X
MAX-Alarm	X		X
MIN-Alarm	X		X
MAX-MIN-Alarm	X		X
F/R-signal	Contact is closed for the forward direction		
2 flow ranges*)	Contact is closed for flow range 2		
Preset counter*)	Contact opens when the preset value is reached (contact closes for the next start command and remains closed during the batch or filling)		
Design	Optocoupler	or	Relay
Terminals COPA-XM Function	G2, P7 E9, C9		G2, P7 39, 40
Terminals MAG-XM Function	P1, P2 EB, CB		P1, P2 96, 97
Pulse output scaled f = 0-10 kHz			
Terminals COPA-XM Function	G2, P7 59, 60		- -
Terminals MAG-XM Function	V5, V6 59, 60		- -
Operating voltage	16 V ≤ U _{CEH} < 30 V 0 V ≤ U _{CEL} < 2 V		16 V ≤ U ≤ 30 V
Operating current	0 mA ≤ U _{CEH} < 0.2 mA 2 mA ≤ U _{CEL} < 15 mA		0 mA ≤ I < 250 mA P ≤ 3 Watt

Output Signal Option
HART®-Protocol

The HART®-Protocol provides for communication between a process control system, Hand Terminal and the EMF field instrument. The communication signals, which are superimposed as an AC voltage on the current output, do not affect any other instruments connected to the current output. This option is only available with a 4-20 mA current output. Terminals: +/-.

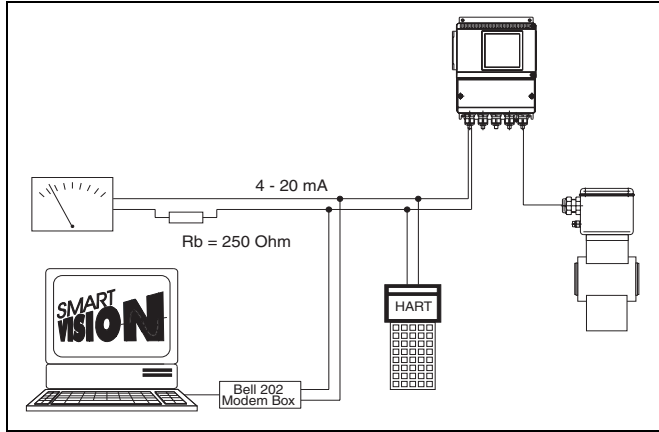

Fig. 31: Communication with HART-Protocol

RS 485

$V_{pp} = 5\text{ V}$. Input impedance: $\geq 12\text{ k}\Omega$,
Max. cable length: 1200 m.
Baudrate: 110-9600 Baud, 14400/28800 Baud.
Max. 32 instruments in parallel on a single bus. A shielded data cable with individually twisted pairs is recommended.
Terminals: V1, V2, V3, V4; Function T-, T+, R-, R+.

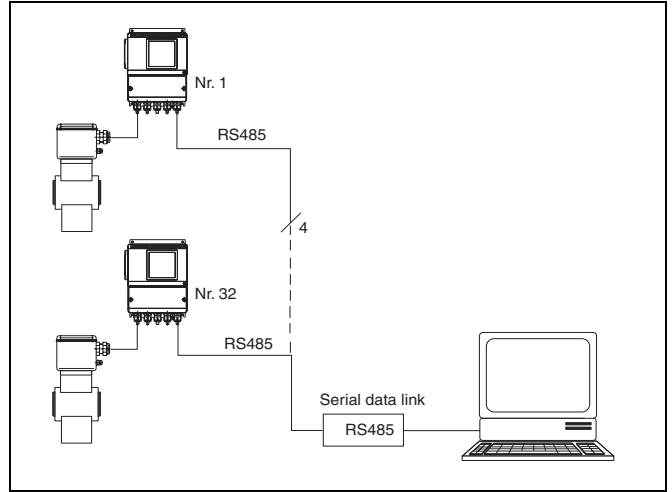

Fig. 32: Communication with RS 485 Data Link

Transmission Type

FSK-Modulation on the current output 4-20 mA per Bell 202 Standard.

Baudrate

1200 Baud

Format

Logic 1: 1200 Hz, Logic 0: 2200 Hz

Cable

AWG 24 twisted

Max. Cable Length

1500 m

Max. Signal Amplitude

1.2 mA_{pp}

Current Output Load

Min.: $>250\ \Omega$, max.: $<1000\ \Omega$

PROFIBUS DP per DIN 19245

Terminals: V1, V2, V4, G2

Terminal	Function	Description
V1	B RxD/TxD-P	Receive/send-data-P
V2	A RxD/TxD-N	Receive/send-data-N
V4	VP	Supply voltage-plus P5V
G2	C DGND	Data reference potential-M5V

A shielded and twisted data cable recommended.
Max. cable length 1200 m (cable Type A)
Characteristic impedance 135-165 Ohm
Max. 32 instruments on a single bus
Baudrate: 9.6-1500 kbit/s
Distributed capacitance $<30\text{ pF/m}$, loop resistance $110\ \Omega/\text{km}$
Tap lines only up to 1 m.
In- and outgoing cables on the same terminal.

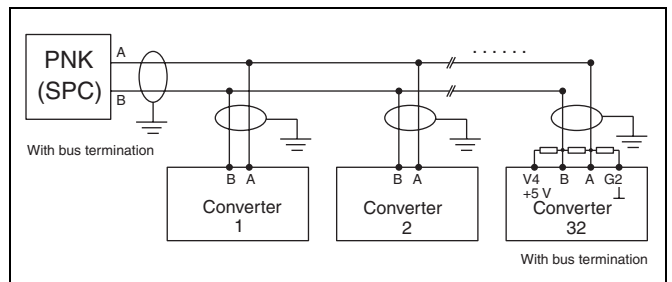

Fig. 33: Bus Connections

GSD [DD] File (Device Descriptor File)

The name of the diskette is ABB_6666.GSD and is included in the shipment. For data link description see separate Document ABB-Part.-No. D184B093U02.

Interconnection Diagram

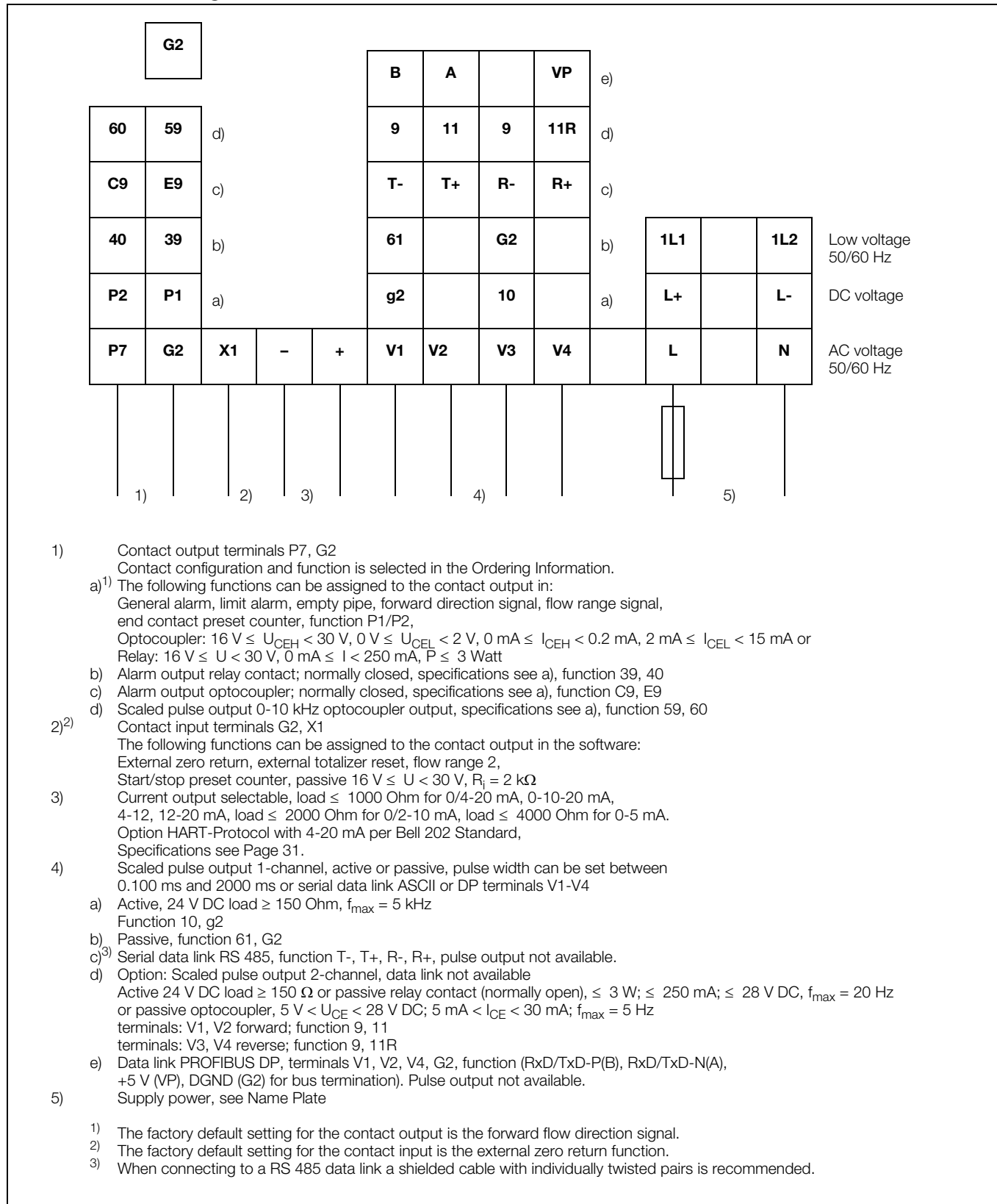

Fig. 34: Interconnection Diagram COPA-XM

Interconnection Diagram for Peripherals

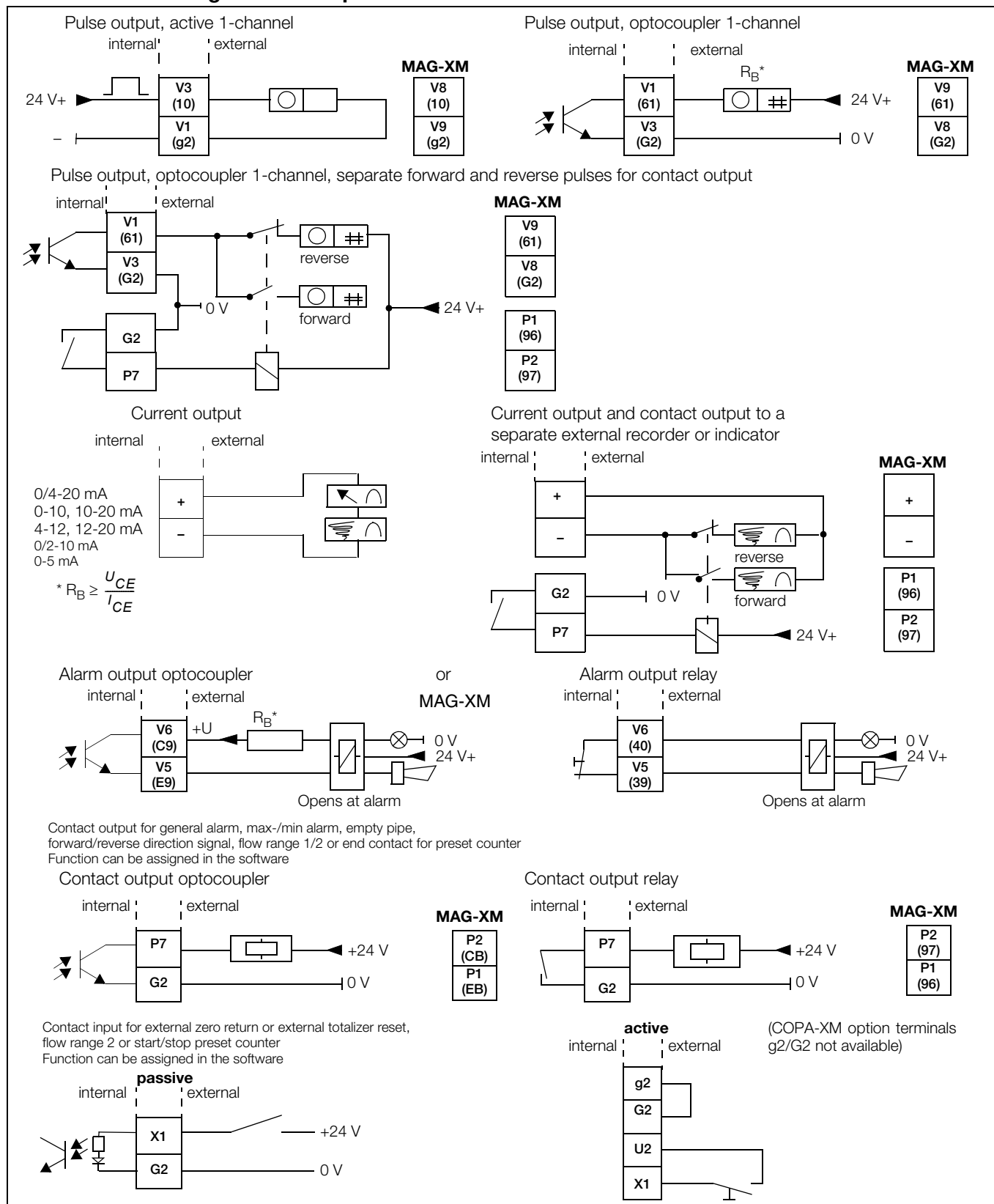

Fig. 35: Interconnection Diagram for Peripherals

Interconnection Diagram Converter MAG-XM

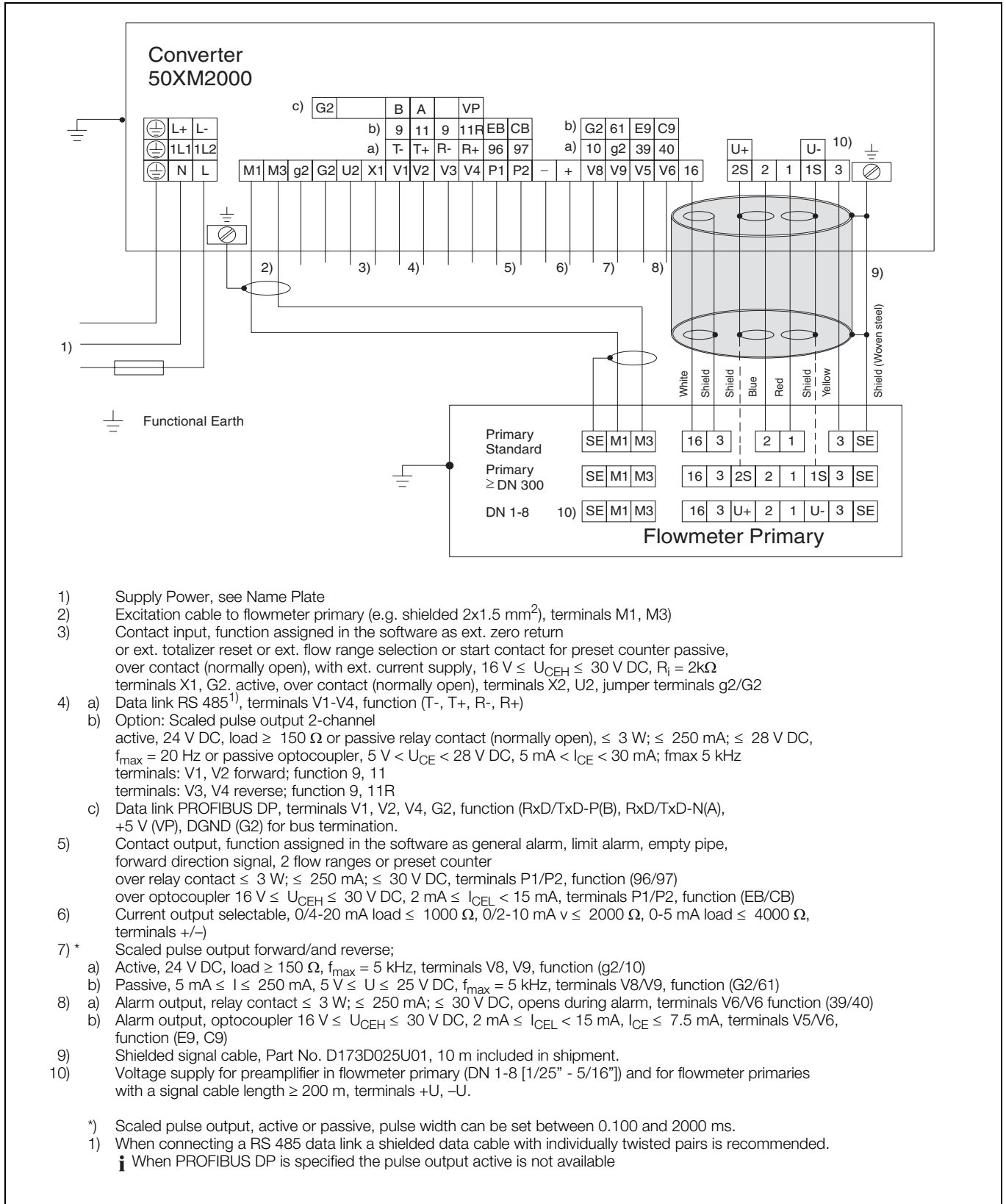

Fig. 36: Interconnection Diagram MAG-XM

Dimension Drawings Field Mount Housing

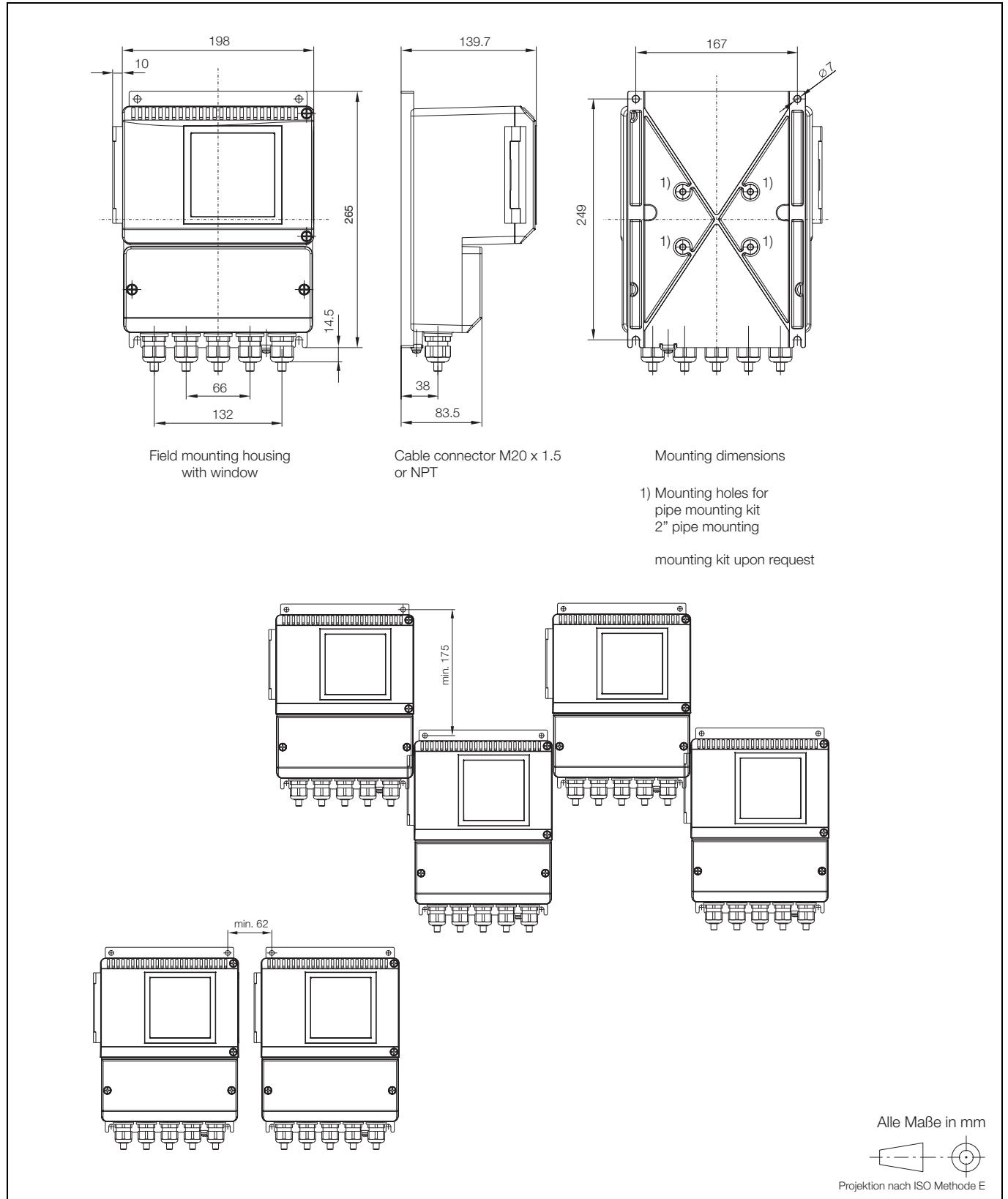

Fig. 37: Dimension Drawings Field Mount Converter Housing with Mounting Suggestions

Ordering Information Test Simulator

Ordering Number					
Flowmeter Primary Simulator	55XC4				
Setting the Flowrate Value					
None (only adapter)		0			
3-Digit switch in 1000 steps		1			
Supply Power¹⁾					
None (adapter order only)			0		
110 V-240 V (50/60 Hz) with Schuko plug			1		
24 V/48 V (AC/DC) with 4 mm plug			2		
110 V-240 V (50/60 Hz) with USA plug			3		
Others			9		
Accessories²⁾					
None				0	
Adapter for converters 50XM2000/50XE4000/E4/50XF4000				1	
Adapter for converter S4				5	
Others				9	
Design Level					
(Specified by ABB Automation Products)					*
Name Plate					
German					1
English					2
French					3

¹⁾ The supply power must agree with the specifications on the converter Name Plate.

²⁾ If both adapters are required, then the Ordering Number for each adapter is to be used.

Software

SMART VISION Communication Tool for HART®
Free 90 day evaluation version upon request.

ABB has Sales & Customer Support expertise in over 100 countries worldwide.

www.abb.com/flow

The Company's policy is one of continuous product improvement and the right is reserved to modify the information contained herein without notice.

Printed in the Fed. Rep. of Germany (06.2006)

© ABB 2006



ABB Ltd.

Oldends Lane, Stonehouse
Gloucestershire, GL 10 3TA
UK

Tel: +44(0)1453 826661
Fax: +44(0)1453 829671

ABB Inc.

125 E. County Line Road
Warminster, PA 18974
USA

Tel: +1 215 674 6000
Fax: +1 215 674 7183

ABB Automation Products GmbH

Dransfelder Str. 2
37079 Goettingen
GERMANY

Tel: +49 551 905-534
Fax: +49 551 905-555

CCC-support.deapr@de.abb.com