

ABB Drives		CAPACITOR REFORMING Inspection Instruction				3AFE 6873 5190 00522808_rev F.DOC	
Dept.	Project	Status	Date	Author	Status	Revision	Page
	ORANGE		17.Sep 2009	Haapala Mari	APPROVED/DAVIDSAINEN JANNE	F	1 / 4

GUIDE FOR CAPACITOR REFORMING IN ACS50, ACS55, ACS150, ACS310, ACS350, ACS355, ACS550 AND ACH550

1 Reforming

The drive DC link capacitors need to be reformed (re-aged) if the drive has been non-operational for more than one year. Without reforming, capacitors may be damaged when the drive starts to operate. The reforming methods introduced in this instruction require that the drive has been stocked clean and dry. It is recommended to reform the capacitors once a year.

1.1 How to check the drive's age

Check the date of manufacture for the drive from the serial number shown on the drive labels. The serial number defines the year and week when the drive was manufactured.

There are two formats of serial numbers. Check which format the drive has and determine the date of manufacture:

Format 1:

YWWXXXXX (8 digits)

Y = year (...6,7,8,9,A,B... for ...2006, 2007, 2008, 2009, 2010, 2011...)

WW = week

Format 2:

XYWWXXXXX (10 digits)

YY = year (...06,07,08,09,10... for ...2006, 2007, 2008, 2009, 2010...)

WW = week

ABB Drives			CAPACITOR REFORMING Inspection Instruction			3AFE 6873 5190 00522808_rev F.DOC	
Dept.	Project	Status	Date	Author	Status	Revision	Page
	ORANGE		17.Sep 2009	Haapala Mari	APPROVED/DAVIDSAINEN JANNE	F	2 / 4

1.2 Reforming time

The intermediate circuit of the drive is kept in its nominal voltage for the reforming time to "wake up" the capacitors. The reforming time required depends on how long the drive has been stocked (non-operational). See figure 1.

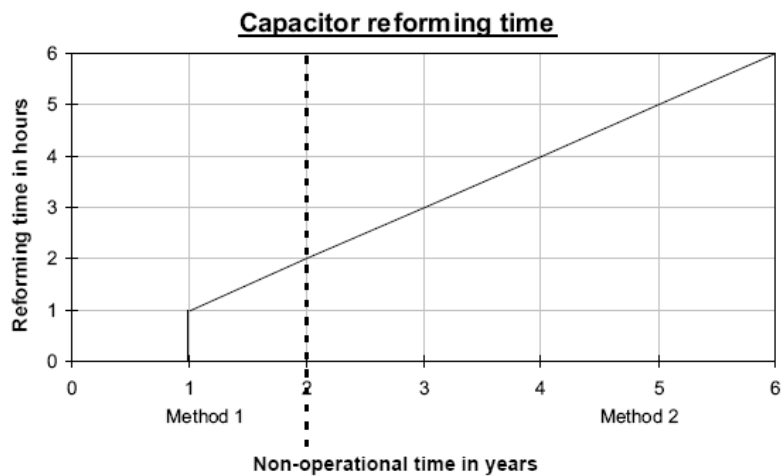

Figure 1. Capacitor reforming time.

1.3 Drives stocked (non-operational) for less than 2 years

Switch the power on to the drive for a time given in figure 1 (Method 1). The drive "wakes up" its capacitors by itself. Power drives up once a year to keep the capacitors in operational condition.

1.4 Drives stocked (non-operational) for 2 years and over

Use method 2A or method 2B for capacitor reforming if the drives have been stocked (non-operational) for two or more years.

ABB Drives			CAPACITOR REFORMING Inspection Instruction			3AFE 6873 5190 00522808_rev F.DOC	
Dept.	Project	Status	Date	Author	Status	Revision	Page
	ORANGE		17.Sep 2009	Haapala Mari	APPROVED/DAVIDSAINEN JANNE	F	3 / 4

a) Method 2A

Capacitors are reformed by switching in a rectifier and resistor circuit, which is connected to the drive input. The reforming circuit is given in figure 2 below. Circuit component values for different voltages are given in table 1. See the reforming time in figure 1.

WARNING: Disconnect the mains supply while the reforming circuit is connected.

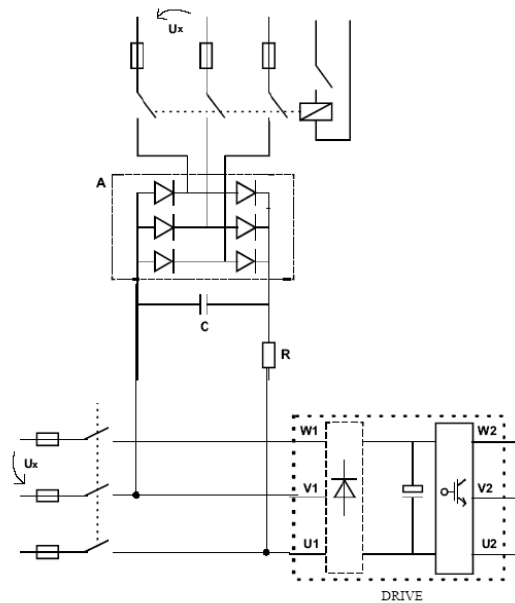

Note! Markings for drive input differs between drive types:

ACS550	U1	V1	W1
ACS150/310/320/350	U1/L	V1/N	W1
ACS50/55	L/R	N/S	

Figure 2. The reforming circuit for method 2A.

Voltage	Recommended components		
	A	R	C
200 V < U_x < 240 V	SKD 82/16	220 Ω / 700 W	22 nF / 2000 V
380 V < U_x < 480 V	SKD 82/16	470 Ω / 1200 W	22 nF / 2000 V

Table 1. Circuit component values for different voltages.

ABB Drives			CAPACITOR REFORMING Inspection Instruction			3AFE 6873 5190 00522808_rev F.DOC	
Dept.	Project	Status	Date	Author	Status	Revision	Page
	ORANGE		17.Sep 2009	Haapala Mari	APPROVED/DAVIDSAINEN JANNE	F	4 / 4

b) Method 2B

Capacitor reforming is based on DC power supply, which is connected to the drive input. The power supply current charges drive capacitors. If the power supply cannot limit the current, the voltage is increased gradually (with e.g. 100V steps). The maximum recommended reforming current is 100mA. An appropriate reforming voltage is $(1.35 \dots \sqrt{2}) * U_x$. See the reforming time in figure 1.

WARNING: Disconnect the mains supply while the reforming circuit is connected.

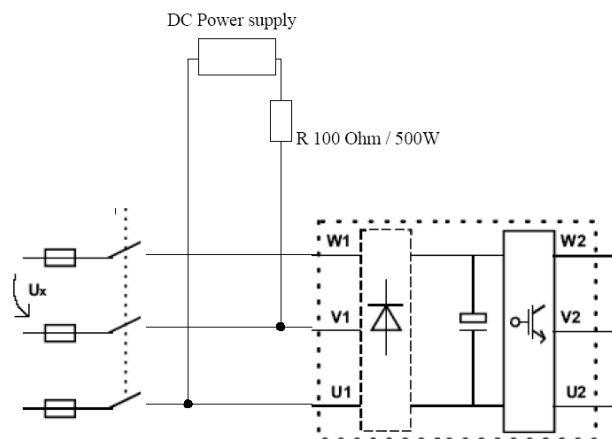

Note! Markings for drive input differs between drive types:

ACS550	U1	V1	W1
ACS150/310/320/350	U1/L	V1/N	W1
ACS50/55	L/R	N/S	

Figure 3. The reforming circuit for method 2B.

2 Replacement

The drive intermediate circuit employs several electrolytic capacitors. Capacitor life can be prolonged by lowering the ambient temperature.

It is not possible to predict a capacitor failure. Capacitor failure is usually followed by an input power fuse failure or a fault trip. Contact ABB if capacitor failure is suspected. Replacements for ACS550 frame sizes R5 and R6 are available from ABB. Do not use other than ABB specified spare parts.