

- **Integral reference-air supply option**
 - avoids necessity for additional equipment
- **Dual fuel data input with manual or automatic selection from up to 17 different fuels**
 - extends the operating range of the system
- **User programmable**
 - enables maximum flexibility of control
- **Two levels of program security**
 - reduces possibility of accidental changes
- **High levels of accuracy, resolution and RFI immunity**
 - provides customer confidence in operation



Superior technology and quality from
the world leader in oxygen
measurement

ZMT Transmitter

The ZMT Zirconia Indicating Transmitter/Alarm Unit is a versatile oxygen analyzer designed primarily to meet the requirements for energy management in the boiler market.

The ZMT is suitable for use with ZFG2 zirconia oxygen probes and can be provided in standard and advanced efficiency form.

The standard analyzer has high/low alarms and isolated retransmission. Display features include:

- Probe mV
- Probe temperature
- Cell constant
- Retransmission range
- Cell 'warming up' indication
- High/low cell temperature fault indication
- Thermocouple failure fault indication
- Provision to measure cell impedance
- Calibration of cell using test gases
- Ability to display a calculated inferred CO₂ value

The standard unit also accepts inputs of probe mV and thermocouples.

The standard analyzer provides oxygen readout with computation based on the probe output voltage. The voltage output is Nernstian in form and follows the equation:

$$E(\text{mV}) = 0.0496T \left(\log_{10} \frac{P_0}{P_1} \right) \pm C(\text{mv})$$

- Where: T = Absolute temperature (°K)
 P₀ = O₂ Partial pressure reference gas (air)
 P₁ = O₂ Partial pressure sample gas
 C = Cell constant (zero offset)
 0.0496 = Faraday's Gas Constant

The advanced analyzer, in addition to the facilities offered by the standard analyzer, provides an efficiency calculation readout by application of the Sievert formula:

$$\text{Efficiency} = 100 - \left[\frac{K(T1 - T2)}{20.8 - \%O_2} \right]$$

- Where: T1 = Flue temperature
 (at economizer or boiler outlet)
 T2 = Inlet-air temperature
 % O₂ = Measured %O₂ in flue gas
 K = Fuel constant dependent on fuel type
 For example;

Natural gas, K = 0.66

Fuel Oil, K = 0.70

Bituminous coal, K = 0.73

The efficiency is displayed as a percentage, with the facility to display inlet-air temperature and flue-gas temperature as required.

Further options are available for serial communications (RS485 ABB protocol) and Auto-calibration.

Auto-calibration requires the addition of the gas panel and test gas cylinders. The test gases are selected by solenoid valves on the gas panel, the valves being switched by relays within the ZMT.

The ZMT can accept a carbon monoxide signal transmitted from another analyzer unit. This signal can be displayed as 'ppm CO'.

The temperature of the zirconia cell is automatically controlled by the ZMT when used with the ZFG2 zirconia probes.

Probe reference-air supply is available, either through pump units or by use of an air regulator operated from the customer's instrument-air line.

Construction and Operation

The ZMT zirconia analyzer is housed in a sheet-steel enclosure, environmentally protected to IP55. It has a hinged front door fitted with a 15-button tactile-membrane switch panel and display window.

There are two blue-filtered, vacuum fluorescent displays visible through the door window. The upper, five-digit display is used for monitoring process values. The lower 20-character, dot-matrix display is used during setting, operating and programming.

Membrane switches on the ZMT unit include:

- % O₂
- Temperature
- Alarm
- Efficiency
- CO₂/CO
- Calibration

The % O₂, efficiency and CO₂/CO switches are dedicated push buttons, that is, when depressed only the required monitored value is displayed. The units of measurement are indicated on the dot-matrix display.

Temperature, alarms and calibration switches, in conjunction with the switch, permit programming and setting up of the various parameters for system operation. Additional pages are available through operation of the switch, such as the Analog Retransmission page, the Relay Allocation page, Diagnostic page and Commissioning page.

Two levels of security are provided to protect various stages of the programming. The first involves operation of the front panel switches, the second, more secure level, is an internal switch.

Single-fuel and dual-fuel boiler operation is monitored by programmable selections from seventeen different fuel types. On dual-fuel applications changeover is implemented either manually or automatically.

The instrument uses a CMOS 6303 microprocessor, a switch-mode power supply, with pulse-width modulation circuitry for analog retransmission, and offers up to three analog outputs (isolated) plus up to four relay outputs in combinations of up to six outputs total.

ZMT Transmitter – Specification

Displays

Measured value

Five-digit, seven-segment blue-filtered, vacuum fluorescent

Information

20-character, single line, dot-matrix, blue-filtered,
vacuum fluorescent

Ranges

Oxygen programmable within the limits of 0 to 25% O₂ to a
minimum span of 5% O₂ linear

Probe 0 to 1400 °C (32 to 2552 °F)
temperature 200 °C [392 °F] span min. for retransmission)

Accuracies

Oxygen concentration

≤ 2 % of reading or ±0.1 % O₂, whichever is the greater

Display and Retransmission

Measurement resolution

Thermocouple, mV, V and mA < 0.1 % span

ACJC error 0.05 °C/°C (0.09 °F/°F) change in
ambient temperature

Thermocouple linearizer ±0.2 °C (±0.36 °F)

Display resolution

±1 digit

O₂ System accuracy

ZMT + ZFG2 probe when calibrated with certified test gas

Display

≤ ± 2 % of reading or ± 0.1 % O₂ whichever is the greater

Retransmission error

≤ 2 % of reading

Error due to ambient temperature variatio

± 0.02 % span/°C (± 0.36 % span/°F) typical

Error due to power supply voltage regulation

None for ± 15 % variation

Power Supply

Voltage requirements

110 V or 230 V (±15 %) 50/60 Hz

Power consumption

150 VA

Insulation, mains to earth (line to ground)

2 kV RMS

Outputs and Set Points

Analog outputs (isolated)

0 to 10 mA, 0 to 20 mA or 4 to 20 mA –

up to three max. into 1 kΩ max. load

Output Modules 1 and 2 programmable

%O₂ any range (5 % min. span within the range of 0 to 25
% O₂ i.e. dual ranging possible)

Temperature any range (200 °C [392 °F] min. span) within the
ranges:

Cell temp. 0 to 1400 °C (32 to 2552 °F)

*Flue temp. 0 to 700 °C (32 to 1292 °F)

*Air temp. –40 to 400 °C (–40 to 752 °F)

*0 to 100 % combustion efficiency

*Available only when Combustion Efficiency option selected.

Output Module 3 programmable

As for Modules 1 and 2 or 2 relays (auto-cal or alarm) or serial
communications

Relay outputs

Maximum of four available

Set points adjustment

Programmable

Relay contacts

Single pole changeover

Rating 250 V AC 250 V DC

3 A AC 3 A DC max.

Loading (non-inductive) 750V 30 W max.

Insulation

Contacts to earth 2 kV RMS

Display Function

%O₂

Temperature	} Efficiency version	Cell temperature
Flue temperature		
Air temperature		

% Combustion efficiency

Inferred CO₂
PPM CO

Environmental Data

Operating temperature limits

0 to 55 °C (32 to 131 °F)

Operating humidity limits

0 to 80 % RH

Protection

IP55

Weight

16.5 kg (36 lb)

Programming

Unless specified otherwise at the time of ordering all instruments are set up as follows:

Standard programming – basic version

Output Module 1	O ₂ range 0 to 25 %
Output Module 2	O ₂ range 0 to 25 % (optional)
Alarms set at	5 % O ₂ EB (Module 1)
	15 % O ₂ EA (Module 2)
	(supplied disabled)

Module 3 (optional) alarms allocated to cell temperature or auto/cal

Alarm 3	low temperature
Alarm 4	high temperature

Standard programming – advanced efficiency version

As basic version plus

Output Module 3	ranged 0 to 100 % Efficiency
Output	4 to 20 mA

For either version

Fuel 1	Gas (selected in manual mode)
Fuel 2	No. 6 oil
CO Display	0 to 4000 ppm (max. range)
CO input	4 to 20 mA

ZMT Transmitter – Overall Dimensions

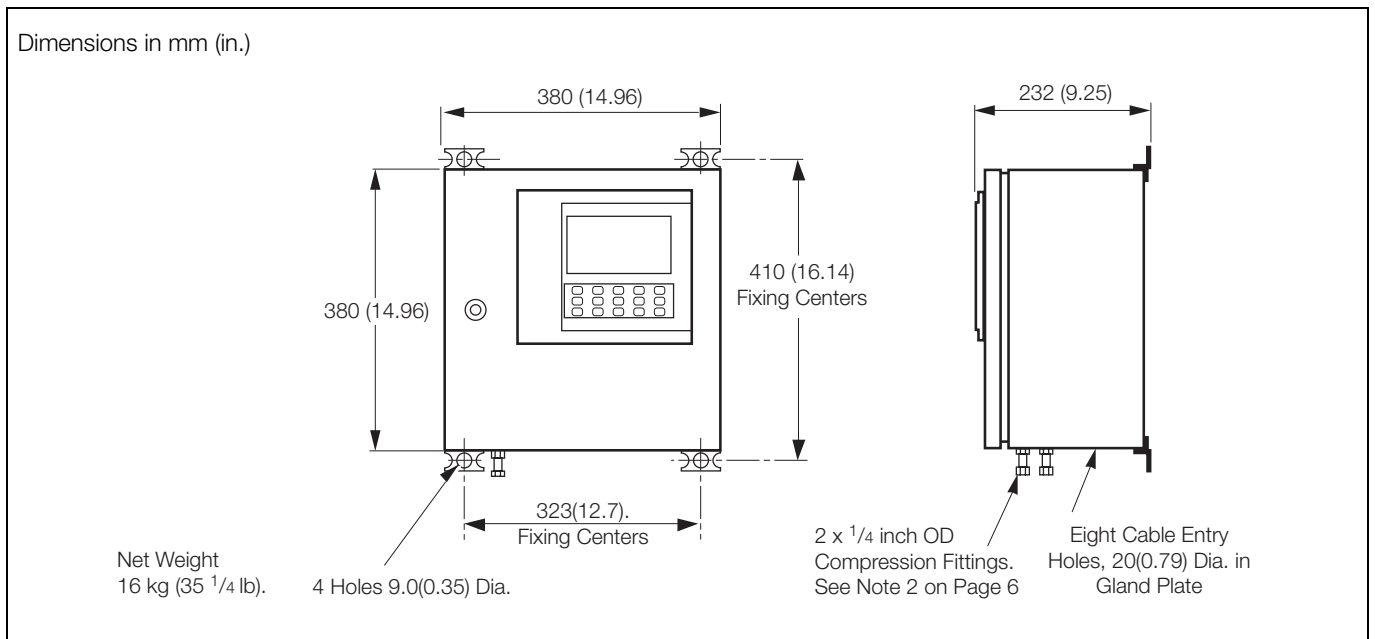

ZMT Transmitter – Ordering Information

ZMT Zirconia Indicating Transmitter/Alarm Unit	ZMT	/ X	X	/ X	XX	XX	X	X	/ X	X	X	X
for use with Probe Type												
ZFG/ZFG2		2										
Reference Air Supply (see Note 2)												
None			0									
Regulator			2									
Pump and flow indicator (ZFG2 only)			3									
Probe Temperature Control												
Temperature control (ZFG2 only)				1								
1st Fuel Option (see Note 1)												
					00							
					01							
					↓							
					17							
2nd Fuel Option (see Note 1)												
						00						
						01						
						↓						
						17						
Program												
Basic							0					
Combustion Efficiency							1					
Humidity in air							2					
Auto-cal basic							3					
Auto-cal efficiency							4					
Program												
None								0				
RS485 ABB protocol								3				
Output Module 1												
None									0			
Analog + relay									4			
Output Module 2												
None										0		
One relay										1		
Analog + relay										4		
Output Module 3												
None											0	
One relay											1	
Two relays (auto-cal or alarms)											2	
Analog + relay											4	
Serial communications											5	
Mains Voltage												
110 V 50/60 Hz												1
230 V 50/60 Hz												2

Note 1

Fuel options available:

00 No fuel specification	09 Distillate oil
01 Natural gas	10 No. 4 fuel oil
02 Propane	11 No. 5 fuel oil
03 Butane	12 No. 6 fuel oil
04 Medium oil	13 Coal (general)
05 Heavy oil	14 Bituminous coal
06 General fuel oil	15 Steam coal
07 Naphtha	16 Anthracite
08 Kerosene	17 Coke

Note 2

Reference-air options 2 and 3 have the air outlet inside the enclosure to suit ZFG2 probe type. Flow rate 500 to 1000 ml/min. (0.02 to 0.04 cu.ft./min approx.)

Zirconia Oxygen Probes

Introduction to the Probes

The ZFG2 Flue Gas Oxygen Probe is the most advanced in the world. A simplified design makes all the component parts easily accessible and field-serviceable. The new universal probe construction gives the ultimate system flexibility while retaining all the features, benefits and reliability of the previous generation.



The ZFG Range of Probes

ZFG2 Probe

Fully interchangeable with previous ABB models and the ability to upgrade from other manufacturer's products, the ZFG2 probe, in common with earlier models is of the in situ type, inserted directly into the boiler smoke box, or flue duct, eliminating the need for costly sampling installations.

Operating in the process temperature range of 20 to 600 °C (68 to 1112 °F) the system gives true wet-analysis of net excess oxygen in combustion gases. The ZFG2 probes can be fitted with an optional flame-trap, thereby extending their use to measurement on gas-fired boilers.

Installation and commissioning are particularly easy and the level of in-service maintenance is extremely low.

Principle of Operation

The detector cell is constructed from stabilized zirconia employing integral platinum electrodes and is specific to oxygen. Air is supplied to the internal (reference) electrode to provide a constant partial pressure of oxygen while the measured gases are in contact with the outer electrode producing a potential proportional to O₂ concentration.

The zirconia probes, constructed from 316 stainless steel, house a ceramic dust filter and flame-arrester, the detector cell, cell-heater and thermocouple. Wiring between the electronics unit and the probe can be carried in a single 6m (20ft) flexible conduit, which is PVC coated for IP65 (NEMA4) rated probes. The conduit also contains the tubing for the reference-air supply.

The standard probe insertion lengths available are 0.4, 1.0, 1.5 and 2.0 m (16, 39, 58 and 78 in.) and fixing to the duct or smoke box is by means of a drilled flange. Stand-off fixings can be used to reduce the insertion length for smaller ducts. A screwed bush is available for fixing the 0.4 m probe to the duct or smoke box.

Where a fast response ZFG2 probe is required the optional Fast-response Cell Adaptor can be fitted. However, this adaptor eliminates the use of flame-arrester and dust filter.

Unique Electrode Technology

The ABB innovative and unique electrode technology employed in these probes ensures continuous operation under severe reducing and sulphurous conditions with extended cell life. This technology gives fast recovery from reducing to oxidizing conditions without shift in calibration.

Independent test reports show an accuracy of $\pm 0.2\%$ for process temperature change from 20 to 600 °C (68 to 1112 °F).

ZFG2 Probe – Specification

Calibration (in situ)

- One point using clean air
- Two point using certified test gas

Flue temperature

20 to 600 °C (68 to 1112°F)

Pressure

Suitable for all normal positive or negative flue pressures

Probe fixing

Flange (or 2 1/2 in. NPT screwed fitting for ZFG2 0.4 m)

Probe insertion

0.4, 1.0, 1.5 or 2.0 m (16, 39, 58 or 78 in.) standard

Flange options (mm)

0.4m ZFG2 Standard

- 6.0 ±0.4 thick x 101.0 ±1 dia.
- 6 holes 7.3 dia. equispaced on 80.0 ±0.2 P.C.D.

1.0, 1.5 and 2.0m ZFG2 Standard

- 12.0 ±1 thick x 165.0 ±dia.
- 6 holes 12.5 ±0.5 dia. equispaced on 140 P.C.D.

Westinghouse Model 132 equivalent

- 6.0 ±0.4 thick x 127.0 ±1 dia.
- 4 holes 9.5 (0.375 in.) dia. equispaced on 99.0 ±0.2 P.C.D.

Westinghouse DIN equivalent

- 12.0 ±1 thick x 185.0 ±0.5 dia.
- 4 holes 18 dia. equispaced on 145.0 ±0.2 P.C.D.

Westinghouse ANSI equivalent

- 12.0 ±1 thick x 153 ±0.5 dia.
- 4 holes 20.0 ±0.2 equispaced on 121.0 ±0.2 P.C.D.

Westinghouse JIS equivalent

- 12.0 ±1 thick x 155.0 ±0.5 dia.
- 4 holes 15 equispaced on 130.0 ±0.2 P.C.D.

Cable length

10 m or 6 m (32 or 20 ft) as fitted. Max. distance probe to electronics unit 100 m (325 ft) using cables EXFG/0194 (Signal) and EXFG/0195 (Heater)

Probe weight

- 0.4 m (16 in.) 6 kg (13.2 lb) (including 6 m [20 ft] cable)
 - 1.0 m (39 in.) 10.8 kg (23.7 lb) (including 6 m [20 ft] cable)
 - 1.5 m (58 in.) 11.6 kg (25.5 lb) (including 6 m [20 ft] cable)
 - 2.0 m (78 in.) 12.5 kg (27.5 lb) (including 6 m [20 ft] cable)
- ERA Citation of suitability for gas fired installations where Group IIB equipment is applicable

Measuring Range

Response rate (typical)

Standard Cell

- <40 s to 63 % of final value
- <1 minute to 90 % of step change
- Initial response ≤ 5 s

Fast-response cell*

- ≤ 7 s to 63 % of step change
- ≤ 12 s to 90 % of step change.
- Initial response ≤ 2 s

Reference gas

- Clean, oil-free air
- Any stable flow in the range 100 to 1000 ml/min

Thermocouple

NiCr/NiAl Pt. 4 BS4937 Type K

Insertion length

0.4 m, 1.0 m, 1.5 m or 2.0 m (16, 39, 58 or 78 in.)

Protection class

Meets requirements of NEMA 4x

Note. * Fast-response Cell cannot be used with Filter and/or Flame-arrester.

ZFG2 Probe – Ordering Information

ZFG2 Zirconia Oxygen Probe	ZFG2	/ X	X	/ X	XX	XX	X	X	/ X
Insertion Length									
0.4 m (16 in.)		1							
1.0 m (39 in.)		2							
1.5 m (58 in.)		3							
2.0 m (78 in.)		4							
Flange Type									
ABB Std.			1						
DIN equivalent/Westinghouse			2						
ANSI equivalent/Westinghouse			3						
Westinghouse/YEW JIS equivalent			4						
Westinghouse Model 132 equivalent (only 0.4 m [16 in.] option)			5						
Special			9						
Conduit Entry									
20 mm (0.78 in.)				1					
½in. NPT				2					
Conduit Length (see Note 1)									
None						00			
1 x standard 6 m (20 ft)						11			
1 x standard 10 m (32 ft)						12			
1 x standard special length						19			
2 x standard 6 m (20 ft)						21			
2 x standard 10 m (32 ft)						22			
2 x standard special length						29			
1 x IP65, 6 m (20 ft)						31			
1 x IP65, 10 m (32 ft)						32			
1 x IP65, special length						39			
2 x IP65, 6 m (20 ft)						41			
2 x IP65, 10 m (32 ft)						42			
2 x IP65, special length						49			
Cell Type									
Standard cell							1		
Standard flow-through cell							2		
Fast-response cell							3		
Flame Arrester (see Note 2)									
None								0	
Flame Arrester								1	
Reference Air Supply									
Internal (within conduit)									1
External									2
Mounting Plate Assembly									
None									0
Standard (see Note 3)									1
Standard (see Note 4)									2
2½ n. NPT adaptor (see Note 5)									9

Note 1. Only with 20 mm conduit entry. Special conduit lengths of less than 10 m (32.5 ft) only, when 20 mm conduit entry fitted.

Note 2. Flame arrester and/or filter not available when Fast-response Cell fitted.

Note 3. Only available with 0.4 m (16 in.) probe fitted with ABB standard flange.

Note 4. Only available with 1 m, 1.5 m and 2 (39, 58, 78 in.) probes fitted with ABB standard flange.

Note 5. Only available with 0.4 m (16 in.) probe fitted with ABB standard flange.

ZFG2 Probe – Overall Dimensions



ABB has Sales & Customer Support expertise
in over 100 countries worldwide

www.abb.com

The Company's policy is one of continuous product
improvement and the right is reserved to modify the
information contained herein without notice.

Printed in UK (09.08)

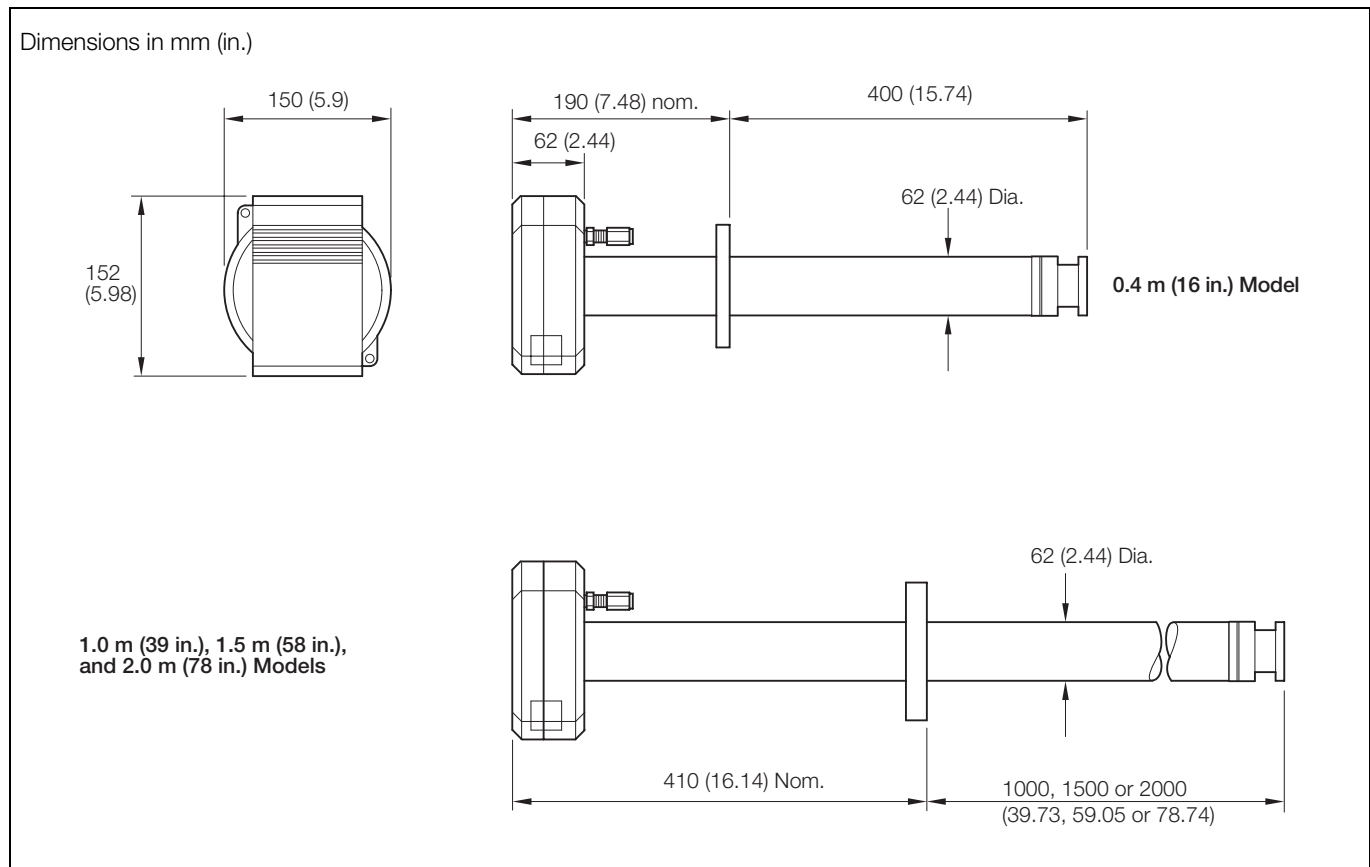
© ABB 2008



ABB Limited
Oldends Lane,
Stonehouse
Gloucestershire
GL10 3TA
UK
Tel: +44 (0)1453 826661
Fax: +44 (0)1453 829671

ABB Inc.
125 E. County Line
Road
Warminster
PA 18974
USA
Tel: +1 215 674 6000
Fax: +1 215 674 7183