



The Company

We are an established world force in the design and manufacture of instrumentation for industrial process control, flow measurement, gas and liquid analysis and environmental applications.

As a part of ABB, a world leader in process automation technology, we offer customers application expertise, service and support worldwide.

We are committed to teamwork, high quality manufacturing, advanced technology and unrivalled service and support.

The quality, accuracy and performance of the Company's products result from over 100 years experience, combined with a continuous program of innovative design and development to incorporate the latest technology.

The UKAS Calibration Laboratory No. 0255 is just one of the ten flow calibration plants operated by the Company and is indicative of our dedication to quality and accuracy.

EN ISO 9001:2000



Cert. No. Q 05907

EN 29001 (ISO 9001)



Lenno, Italy – Cert. No. 9/90A

Stonehouse, U.K.



Electrical Safety

This equipment complies with the requirements of CEI/IEC 61010-1:2001-2 'Safety Requirements for Electrical Equipment for Measurement, Control and Laboratory Use'. If the equipment is used in a manner NOT specified by the Company, the protection provided by the equipment may be impaired.

Symbols

One or more of the following symbols may appear on the equipment labelling:

	Warning – Refer to the manual for instructions		Direct current supply only
	Caution – Risk of electric shock		Alternating current supply only
	Protective earth (ground) terminal		Both direct and alternating current supply
	Earth (ground) terminal		The equipment is protected through double insulation

Information in this manual is intended only to assist our customers in the efficient operation of our equipment. Use of this manual for any other purpose is specifically prohibited and its contents are not to be reproduced in full or part without prior approval of the Technical Publications Department.

Health and Safety

To ensure that our products are safe and without risk to health, the following points must be noted:

1. The relevant sections of these instructions must be read carefully before proceeding.
2. Warning labels on containers and packages must be observed.
3. Installation, operation, maintenance and servicing must only be carried out by suitably trained personnel and in accordance with the information given.
4. Normal safety precautions must be taken to avoid the possibility of an accident occurring when operating in conditions of high pressure and/or temperature.
5. Chemicals must be stored away from heat, protected from temperature extremes and powders kept dry. Normal safe handling procedures must be used.
6. When disposing of chemicals ensure that no two chemicals are mixed.

Safety advice concerning the use of the equipment described in this manual or any relevant hazard data sheets (where applicable) may be obtained from the Company address on the back cover, together with servicing and spares information.

Contents

1 General	2	6 Error Messages and Troubleshooting	14
1.1 Reagents Available for AW101	2	7 Further Information	15
2 Installation and Commissioning	3	8 Maintenance	15
2.1 Installation	3	8.1 Description of Maintenance Work	15
2.2 Sample Supply	4	8.2 Cleaning the Filter Housing	16
2.3 Electrical Connection	4	9 Spare Parts List	17
2.3.1 Basic Requirements	4	10 AW101 Testomat® Block Diagram	18
2.4 Plug Connector	4	10.1 Terminal Block Identification	19
2.5 Sample to Drain	4	11 Specification	20
3 Commissioning	5		
4 Description of Displays and Operating Features	6		
4.1 Display Functions	6		
4.2 Limit Value Displays	6		
4.3 Alarm Message	6		
4.4 Description of the Relay Outputs	7		
4.5 Diagnostic Alarm Messages	7		
4.6 Description of the Signal Inputs and Output	8		
4.7 Function Characteristics	8		
4.8 Analysis Cycle	9		
4.9 Displayed Unit	9		
4.9.1 Type of Reagent	9		
4.9.2 Setting the Timer	9		
4.9.3 Interval Pause	9		
4.10 Monitoring the Limit Value	9		
4.11 Hysteresis	9		
4.12 Logic Functions of Limit Value Outputs LV1 and LV2	10		
4.13 Low-level Reagent Alarm (BOB Function)	10		
4.14 STOP Function	10		
4.15 Water Meter	10		
4.16 Analog Output	10		
5 Menu Structure	11		
5.1 Selection and Input	11		
5.1.1 Start Menu	11		
5.2 Selection	11		
5.3 Entry function (M menu only)	11		
5.4 End Menu	11		
5.5 Information Menu	11		
5.6 Program Menu M	12		
5.7 Basic Program	13		
5.8 Program Values	13		
5.8.1 Structure of the Basic Programming	13		

1 General

The AW101 has been developed as a simple device to monitor the quality of water from softeners. Applications include laundries, utility boiler plants, soft drinks factories, brewing, food processing and potable water plants. It provides an alarm for high hardness that starts an automatic regeneration of the ion exchange beds used most commonly in these applications.

The AW101 uses one of four reagents that changes from green to red at a predetermined water hardness level. The reagent is added to a known volume of sample via a small pump until a color change takes place. The volume of reagent required to bring about this reaction (monitored photo-electrically) indicates the level of hardness of the water sample. The AW101 also provides an analog signal, with a range determined by the choice of one of the four reagents available.

The digital display on the front of the monitor and the analog output show the value of the last analysis cycle.

Three alarm outputs are provided – two concentration alarms for control purposes and one alarm to drive an audible signal device. There are also inputs for a flow device and suspension of the flow cycle.

1.1 Reagents Available for AW101

The available ranges are determined by the choice of appropriate reagents. A summary of the different possibilities are shown in Table 1.1.

		Parameter/Type of Reagent			
		Water Hardness AW101901 (TH2005)	Water Hardness AW101 902 (TH2025)	Water Hardness AW101903 (TH2100)	Water Hardness AW101904 (TH2250)
Unit	°dH (Resolution)	0.05 ... 0.50 (0.01)	0.25 ... 2.50 (0.05)	1.0 ... 10.0 (0.2)	2.5 ... 25.0 (0.2)
	°F (Resolution)	0.09 ... 0.89 (0.02)	0.45 ... 4.48 (0.1)	1.79 ... 17.9 (0.4)	4.48 ... 44.8 (0.4)
	ppm CaCO ₃ (Resolution)	0.89 ... 8.93 (0.2)	4.47 ... 44.7 (0.9)	17.9 ... 179 (3.8)	44.7 ... 447 (3.8)
	mmol/l (Resolution)	0.01 ... 0.09 (0.01)	0.04 ... 0.45 (0.01)	0.18 ... 1.79 (0.04)	0.45 ... 4.48 (0.04)

Table 1.1 Reagents Available for AW101

Note.

- A consistently reliable result can only be guaranteed by the AW101 with the use of original ABB reagents. Failure or problems which are caused by the use of different indicators are not covered by the warranty.
- When monitoring hardness, larger quantities of heavy-metal ions in the softened water can affect the color reaction, especially iron above 0.5 mg/l, copper above 0.1 mg/l and aluminium above 0.1 mg/l (brownish-red color indication). Measurement should be made within the range of 4 ... 10.5 pH.
- At a concentration of more than 100 mg/l of CO₂ in the water, the excess must be removed by installing an appropriate debubbler in the feed water line to the AW101 unit.

2 Installation and Commissioning

2.1 Installation

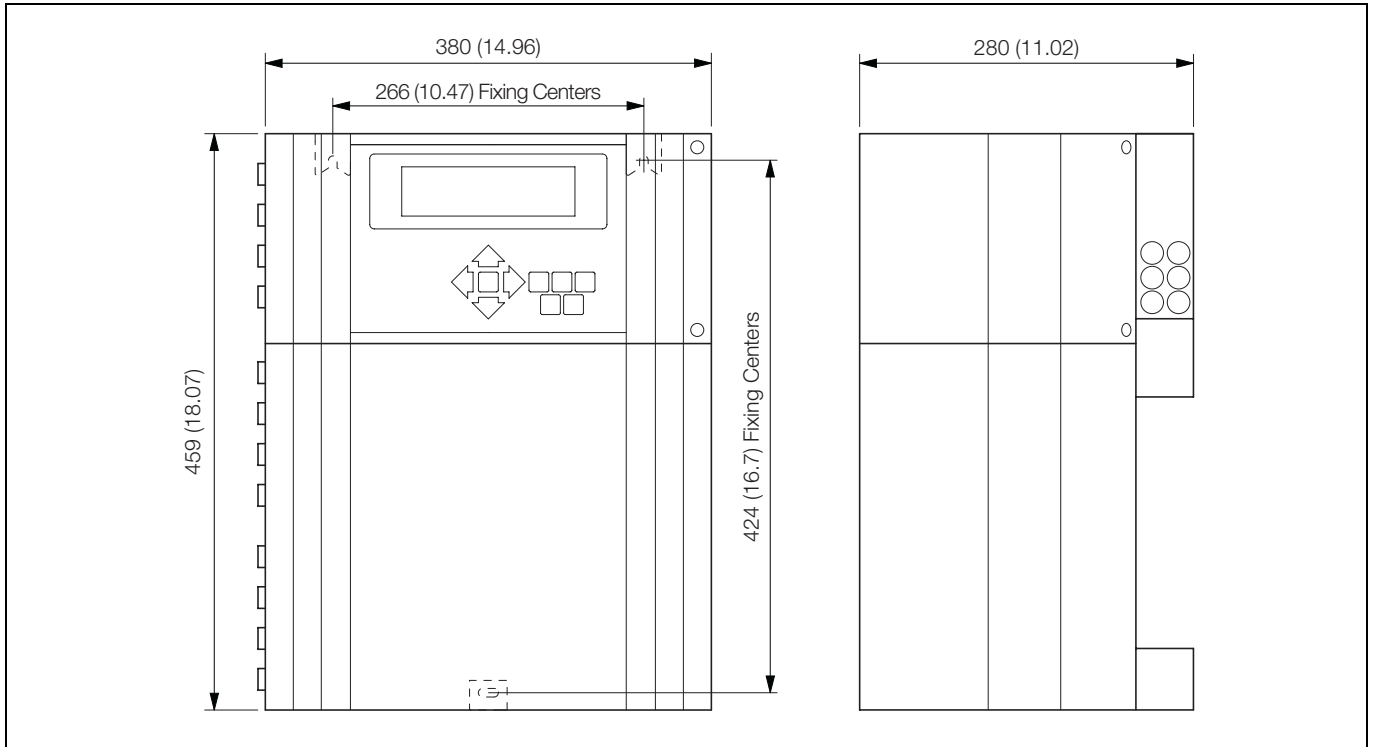

Fig. 2.1 Dimensions

Note. The unit doors swing to the left when opened. Allow sufficient space for the doors to open when preparing for installation.

1. Fix the unit vertically to the wall and secure using suitable fixings.
2. Avoid tension of the housing.

2.2 Sample Supply

The temperature of the sample water must be between 10 and 40 °C (50 and 105 °F). Higher water temperatures can lead to damage to all parts coming into contact with water (for example, the filter housing or measuring chamber). Lower water temperatures can cause misting on the sight-glass windows.

In the event of higher temperatures, install a cooler in the sample line of the AW101.

Position the sample line (fitted with a hand-operated shut-off valve) as close as possible to the outlet from the water softening plant. Keep the sample line to the AW101 as short as possible and not longer than a maximum of 5 m (16.04 ft.). It is important that the sample line connection is taken vertically from the top of the main soft water line in order to prevent dirt particles from entering into the measuring chamber.

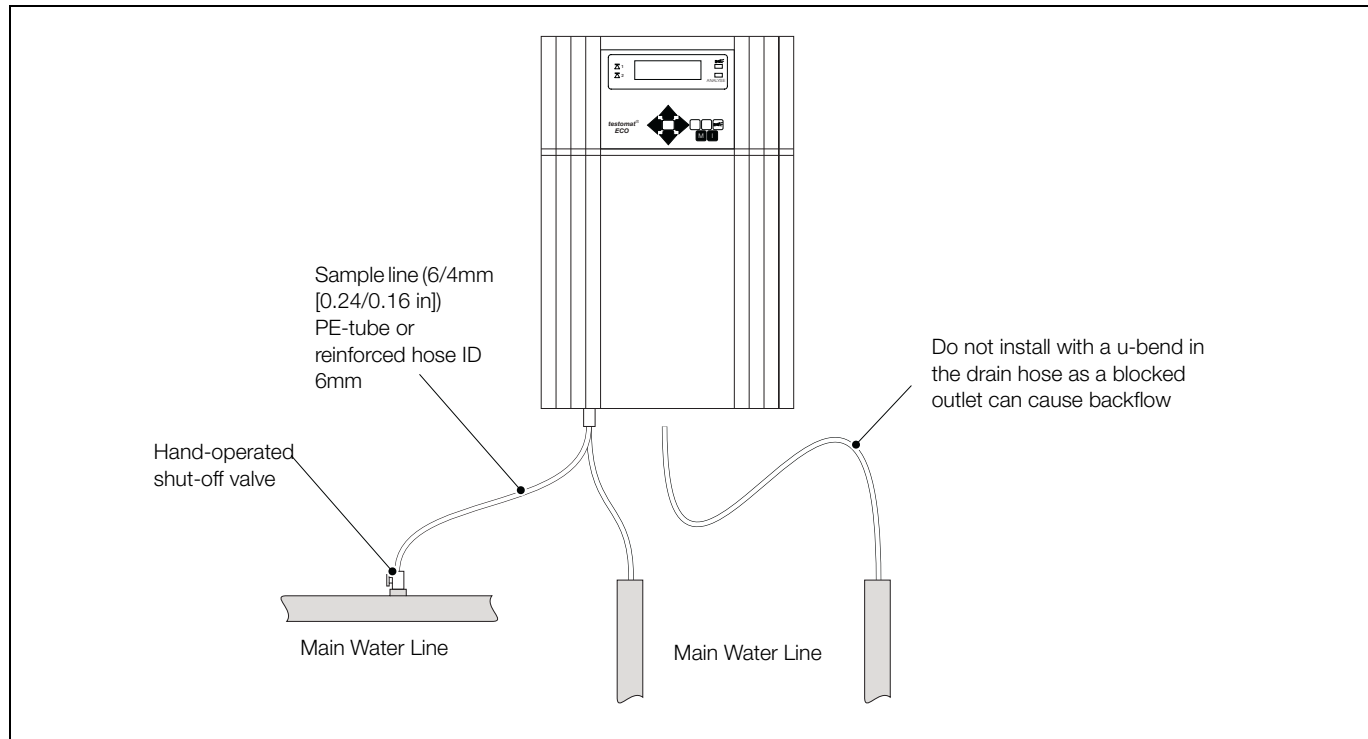

Fig. 2.2 Sample Inlet Installation

2.3 Electrical Connection

Check the supply voltage on the rating plate.

2.3.1 Basic Requirements

Keep the external cables (for example, water meter and interface) clear of the power cables and as short as possible.

2.4 Plug Connector

The unit is equipped as a standard with a plug connector for opaque plastic hoses (external diameter 6 [0.24 in.] mm/internal diameter 4 mm [0.16 in.]).

2.5 Sample to Drain

The feed water flows through the measuring chamber then, via the outlet pipe, to the drain (hose connection internal diameter 14 mm [0.44 in.]). Ensure, by using a funnel for example, that the water can run freely to drain and cannot backup into the measuring chamber. Use a hose impervious to light for the drain pipe (to discourage algae formation).

3 Commissioning

To commission the AW101:

1. Connect a full reagent bottle.
2. Attach the vacuum connection onto the reagent bottle using the union nut.
3. Switch the unit **on** and press the **STANDBY** key.

In this mode, an analysis is prevented from being carried out before a correct program has been selected to prevent an error or alarm message.

4. Bleed the dosing pump and the capillary by repeatedly pressing the **Manual** key on the dosing pump. Ensure all air is removed from the tubing (if necessary, tighten up the connections).

5. Program the unit as applicable to your requirements, for example:

Mode of Operation ➤ Type of reagent ➤ Displayed unit
➤ Limit values

For a description of programming see page 11.

6. Remove all air from the water supply side of the unit by manual flushing.

M ➤ SERVICE ➤ MANUAL OPERATION ➤ FLUSH
(**ENTER** press repeatedly).

Continue flushing until no bubbles can be seen in either the measuring chamber or the filter housing.

7. Check all connections for tightness.
8. Press the **Manual** key to carry out the first analysis.

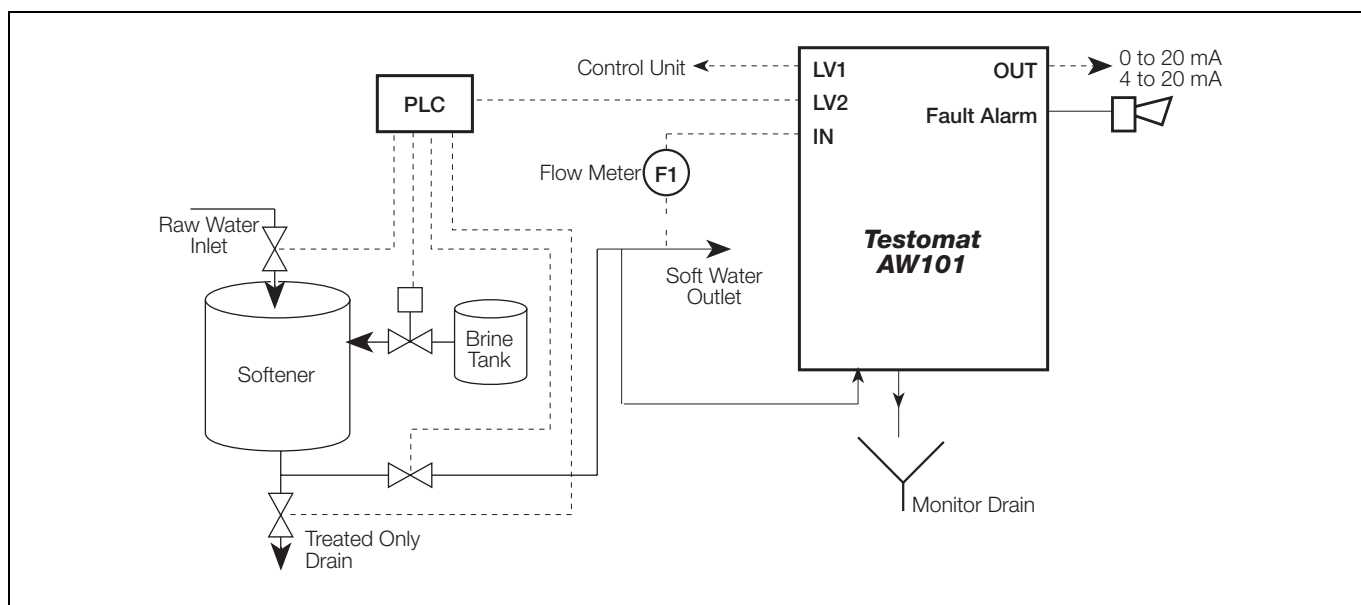

Fig. 3.1 Installation Diagram

4 Description of Displays and Operating Features

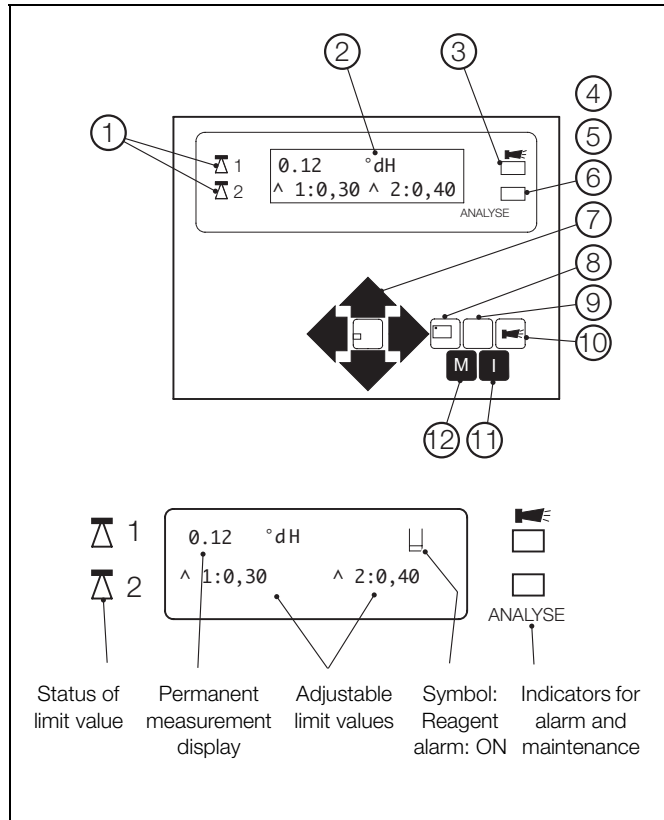

Fig. 4.1 Display Functions

- ① Status of Limit Value Displays
Displays the status of the limit values LV1 and LV2.
- ② Text Display
Displays the current analysis, all important status results and programming data in a 2-line LCD.
- ③ Alarm
Displays a function fault.
- ④ Power Switch
The On/Off switch is located on the right-hand side panel.
- ⑤ Unit Fuse (inside the unit)
Protects outputs against overload and short circuit.
- ⑥ Analysis Message
Displays current analysis.

- ⑦ Programming Keys (Cursor block with ENTER)
These keys are used to enter all values and programming data.
- ⑧ 'Manual' – manual start of an analysis.
- ⑨ 'STANDBY' – manual analysis stop/standby.
- ⑩ 'Alarm' – cancels alarm message.
- ⑪ I-Key
Access all unit information.
- ⑫ M-key
Access the programming menu.

4.1 Display Functions

Status of limit values 1 and 2

△ 1: The red display lamp is lit if limit value 1 (LV1) is reached or exceeded. It turns green if the measured value falls below the set limit value.

△ 2: The red display lamp is lit if limit value 2 (LV2) is reached or exceeded. It turns green if the measured value falls below the set limit value.

Status and measured value display:

- In continuous operation the current measured value is shown in the upper line.
- When the measured value falls below the measuring range '<' is displayed: for example, <0.05 °dH
- When the measured value exceeds the measuring range '>' is displayed: for example, >10.0 °dH
- When the analysis interval is stopped while in operation (Analysis Stop), STANDBY and measured value are displayed alternately.
- The  icon appears if the low-level reagent alarm is active.

4.2 Limit Value Displays

The adjustable limit values are shown in the bottom display line.

4.3 Alarm Message

A fault condition is signalled by a red light.

Error messages are displayed alternately with the normal display text and can only be deleted by cancellation and correction of the fault.

4.4 Description of the Relay Outputs

LV1 and LV2 limit value outputs

To signal that a limit value has been exceeded, two volt-free relay contacts are available. For both contacts the limit values, hysteresis and alarm action can be programmed independently:

Function	Type of contact	Action
LV1 active when in excess of limit value 1	Volt-free change-over contact	Programmable: <ul style="list-style-type: none"> ■ Continuous contact ■ Impulse (1 ... 99 seconds/minutes) ■ Interval (1 ... 99 seconds/minutes) ■ Two-step regulator ■ Hysteresis (1, 2 or 3 limit value in excess)
LV2 active when in excess of limit value 2	Volt-free change-over contact	Programmable: <ul style="list-style-type: none"> ■ Continuous contact ■ Impulse (1 ... 99 seconds/minutes) ■ Interval (1 ... 99 seconds/minutes) ■ Hysteresis (1, 2 or 3 limit value in excess)

Table 4.1 Relay Outputs

4.5 Diagnostic Alarm Messages

The Alarm output is a volt-free change-over relay contact. During normal operation the contact between terminals 16/17 is closed and the one between terminals 15/16 is open. If the voltage fails or the alarm is activated, the contact between terminals 15/16 is closed and the one between 16/17 is open.

The unit is equipped with a range of alarm notification functions.

- Activation:

The Alarm output remains activated (with terminals 15/16 closed) as long as the fault persists.
- Alarm Indicators:

Text and a red LED Alarm on the display indicate a fault.
- Alarm cancellation:

The Alarm output condition is cancelled using the Horn key.

An error message can only be deleted after the fault has been corrected.

Exception – reagent low level, this message is confirmed in the M-menu by entering in the new reagent level.

The following conditions activate the Alarm output and are displayed:

- Low-water pressure
- Low reagent level
- Function fault optics
- Measuring fault – dirty chamber
- Measuring fault – analysis
- Measuring fault – turbid sample
- Function fault – dosing pump
- Measuring range exceeded
- Function fault outlet to drain

Error messages are described in Table 6.1, page 14.

For a more detailed description of the programming refer to page 11. For general maintenance refer to page 15.

4.6 Description of the Signal Inputs and Output

Caution. Connect the signal inputs 'Stop' and 'IN' to volt-free contacts only.

Function	Type of contact	Action
Stop		
External analysis stop (for example, via flow controller or from a process controller)	Programmable normally closed/normally open volt-free.	No analyses are carried out while the contact at the input is open or closed.
IN		
Water meter input	Normally closed/ normally open volt-free or turbine	Analysis starts after a configured sample quantity is reached.

Table 4.2 Stop External Analysis Stop

M ➔ BASIC PROGRAM ➔ PROGRAM VALUES ➔ INPUT STOP

M ➔ BASIC PROGRAM ➔ PROGRAM VALUES ➔ WATER METER

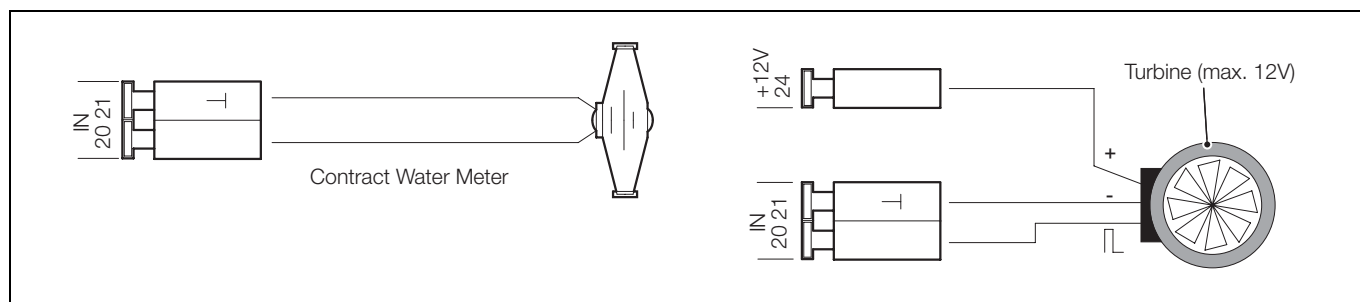

Fig. 4.2 Installation Example for the Water Meter

Function	Terminal	Action
Current 0/4-20mA	max. load 350 Ohm	programmable 0 - 20 mA or 4 - 20 mA

Table 4.3 OUT Interface Output

M ➔ BASIC PROGRAM ➔ PROGRAM VALUES ➔ 0/4-20 mA

4.7 Function Characteristics

Mode of operation (Analysis controller)

- Time Control – internal triggering by a timer. The shortest interval = 0 minutes between analyses, longest interval = 99 minutes. – see page 9.

The analysis interval is determined by the duration of the set flush times the programmed (interval) and the duration of the analysis. The analysis duration is a direct function of the value to be measured.

- Quantity Control – triggered by the water meter. Minimum interval = 1 liter, maximum interval = 9999 liters. After the programmed water quantity is measured, the analysis is carried out. Prior to the analysis, the capillary and the measuring chamber are flushed (observe the programmed flush times).

The current analysis interval can be interrupted by initiating the 'Stop' relay contact.

4.8 Analysis Cycle

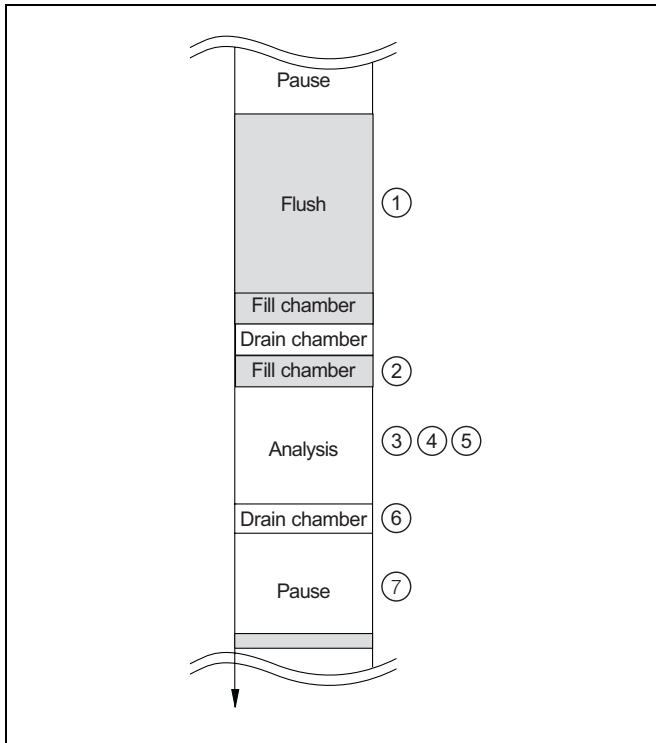

Fig. 4.3 Analysis Cycle

The analysis cycle comprises the following steps:

- ① The flow cell is flushed thoroughly to ensure that an uncontaminated sample is analysed. This flush time is programmable to suit the process sample and conditions.
- ② The measuring chamber is filled with a known sample volume.
- ③ The sample is checked optically to ensure it is clean.
- ④ A quantity of reagent is titrated and the end-point (color change) is reached. The result is evaluated and displayed. If the hardness value is outside the range determined by the reagent used, an alarm state is triggered and ③ ① ④ and ⑤ are known as the analysis period.
- ⑤ The chamber is drained.
- ⑥ There is a pause period (programmable) until the next analysis cycle is started.

4.9 Displayed Unit

Programmed hardness unit is displayed. You have the choice of °dH, °f, ppm CaCO₃ and mmol/l. The unit entered is displayed as programmed.

4.9.1 Type of Reagent

Select the reagent type used in the unit – for example, reagent AW101901 means 0.89 ppm CaCO₃ lower limit of the measuring range and 8.93 ppm CaCO₃ upper.

4.9.2 Setting the Timer

To ensure the analyzed sample represents the current value, the sampling tube must be sufficiently well flushed taking its length into consideration. If the installation has been out of operation for a long period or in the case of long analysis intervals, a flushing time in excess of 60 seconds is recommended. A flush is initiated by simultaneously opening the AW101 inlet and the outlet valves.

The analysis interval depends directly on the programmed flush time. If a flush time of, for example, 90 seconds is set, the analysis interval itself cannot be shorter than 90 seconds.

Example: For 3 bar pressure, a connection longer than 5 m (16.6 ft), an internal tube diameter of 4 mm (0.16 in), a minimum internal flushing time of 10 seconds is required to ensure a valid sample is taken from the sampling tube. The quantity of flush water for an internal flush of 1 minute is 0.5 liter.

4.9.3 Interval Pause

In the case of timed triggering of the analysis, the interval between two analyses (plus flush time) is determined by the interval pause. To carry out analyses continuously, set the pause to 0. The longest pause is 99 minutes.

4.10 Monitoring the Limit Value

Two limit values are programmable continuously. The range for the limit value depends on the reagent type used and on the programmed unit. The functions of these outputs can be programmed independently from each other.

When limit value LV1 is exceeded, the Status LED LV1 is lit RED and relay output LV1 reacts as programmed in the switch function. If the limit value is not exceeded, the display light remains GREEN. The unit operates in the same way for limit value LV2.

4.11 Hysteresis

Each limit value output reacts only after the 1st, 2nd or 3rd bad analysis result has been detected (suppression of the first or the second measured value).

This increases the reliability during the evaluation of the analysis, for example, after the measuring point has been switched over or if the sampling line has possibly not been flushed sufficiently. The hystereses of the two outputs LV1 and LV2 can be set independently from each other.

Operation – with a hysteresis of 2 a further analysis is carried out immediately after the limit value has been exceeded.

The corresponding output is energized only if the limit value of this analysis is exceeded again. If a hysteresis of 3 is set, the corresponding output reacts only after the limit value has been exceeded three times in succession.

4.12 Logic Functions of Limit Value Outputs LV1 and LV2

The logic limits are:

- Logic function 0, Duration

Output relay LV1 or LV2 energizes when the measured value rises above limit value LV1 or LV2. If the measured value falls below the limit value LV1 or LV2 the relevant relay de-energizes again.

- Logic function 1, Impulse

If the measured value rises above limit value LV1 or LV2, the relevant output energizes for a set time t . Independent of the time taken for the limit value to rise above the set limit, the relevant output always remains in the ON position for the set time.

- Logic function 2, Interval

If the measured value rises above one limit value, the relevant output energizes at intervals of the set time (Impulse/Pause).

- Logic function 3, Two-point

If the upper limit value LV1 is exceeded, the output relay LV1 energizes. If the lower limit value LV2 falls below the set limit, output relay LV1 de-energizes.

Output relay LV2 energizes according to the programmed logic function.

This function is possible only if different values are selected for LV1 and LV2. For example for LV1 = 0.2 °dH and for LV2 = 0.1 °dH.

4.13 Low-level Reagent Alarm (BOB function)

In certain steam boiler installations, the possibility of an unsupervised boiler operating with a depleted supply of reagent has safety implications (because untested sample is allowed to flow through the boiler system). To overcome this problem, the AW101 employs a programmable low-level reagent alarm operation function. This monitors the reagent constantly and an alarm is triggered if the available reagent quantity falls below the quantity required for 72 hours usage.

BOB on: Continuous monitoring of the residual reagent quantity. ALARM message when the available quantity falls below the minimum quantity for the set period – 'Alarm' flashes, the Alarm output is energized.

BOB off: Without BOB function – the residual reagent quantity is monitored only for the minimum quantity (10% level).

Example: BOB-Duration = 72 Hours.

Number of analyses per hour = 10.

Necessary quantity of reagent for 72 h = 72 h x 10.

Analysis/h x (3 x 30) µl/Analysis = 64.8 ml.
(Corresponds to approximately 13% of a full level bottle).

4.14 STOP Function

The active analysis cycle can be interrupted by pressing the STOP/Standby key on the display pad. The cycle can be interrupted remotely/automatically using the STOP relay.

4.15 Water Meter

For quantity-dependent analysis triggering it is necessary to connect a water meter to the IN2 input. Program the corresponding water meter rating under menu item WATER METER or enter the impulse number of the turbine water meter.

4.16 Analog Output

Another possibility for monitoring the analysis is the connection to a process recorder or supervisory system. For this purpose the unit is equipped with a programmable current output.

A maximum working resistance of 350 Ω must not be exceeded. In situations where interferences might occur and for very long cables (approximately 20 m [65 ft.]), use a screened cable.

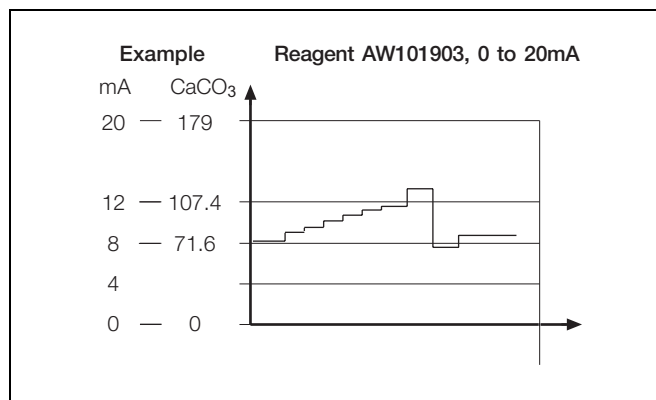

Fig. 4.4 Reagent AW10903

5 Menu Structure

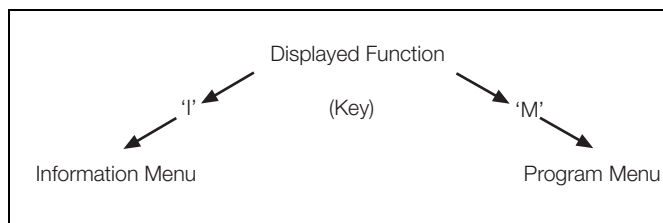

Fig. 5.1 Menu Structure

5.1 Selection and Input

5.1.1 Start Menu

Select one of the two menus by pressing the M or the i key.

5.2 Selection

The active line position is displayed in CAPITALS. Using the ENTER key, the line is activated to enter a submenu. Using the ▼ key, the next parameter appears below the lowest display line; in this way you scroll through the menu.

5.3 Entry Function (M menu only)

The entry functions are:

- Select a programming step using the ▲ ▼ keys and activate the entry function by pressing the ENTER key.
- In the case of digits to be entered, the first digit to be modified flashes. Change a value using the ▲ ▼ keys.
- Use the ◀ ▶ keys to confirm an entry and simultaneously change to the next or the preceding digit (the entry to be changed starts flashing).
- Terminate the entry function by pressing ENTER. The following line is activated.
- To go up one level of the menu press the M key.

5.4 End Menu

To go up one level of the menu press the M or i key.

After returning from the highest menu level the unit is again in display mode.

5.5 Information Menu

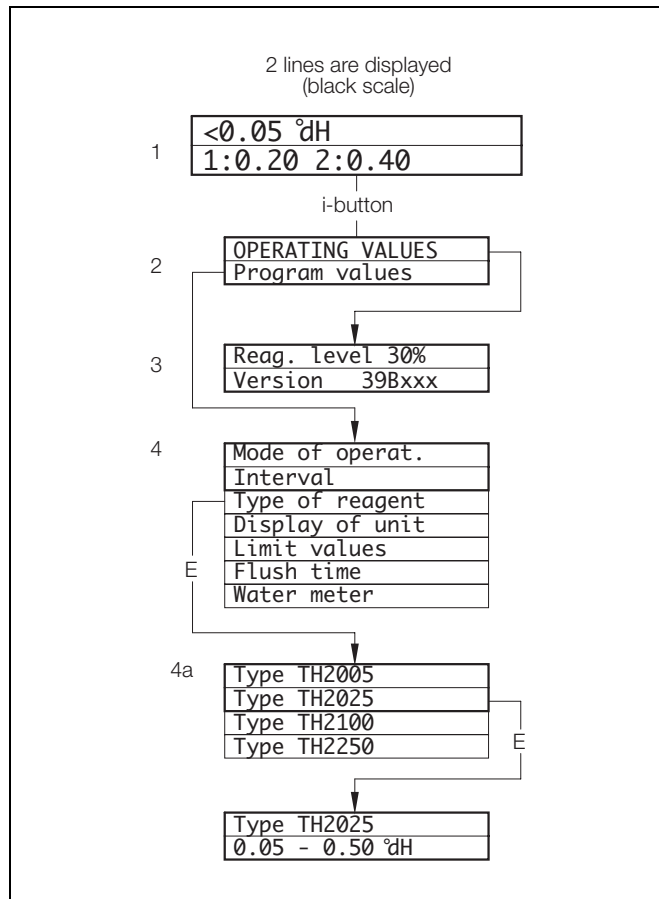

Fig. 5.2 The Information Menu Structure

The information menu calls-up the active settings and status of the unit – see Fig. 5.2

- ① Call
Press the i key to open the information menu.
- ② Operating values:
 - Display of current values
 - Reagent level
 - Software version.
- ③ Program values.
- ④ Press the arrow keys to call up the menu item Program values. Press ENTER to open the list with the set values. The active setting of a parameter can be queried by pressing ENTER:
For example:
i ➔ INFORMATION ➔ PROGRAM VALUES ➔ TYPE OF REAGENT
The selected function is marked by a star (in this context there are no active lines).

5.6 Program Menu M

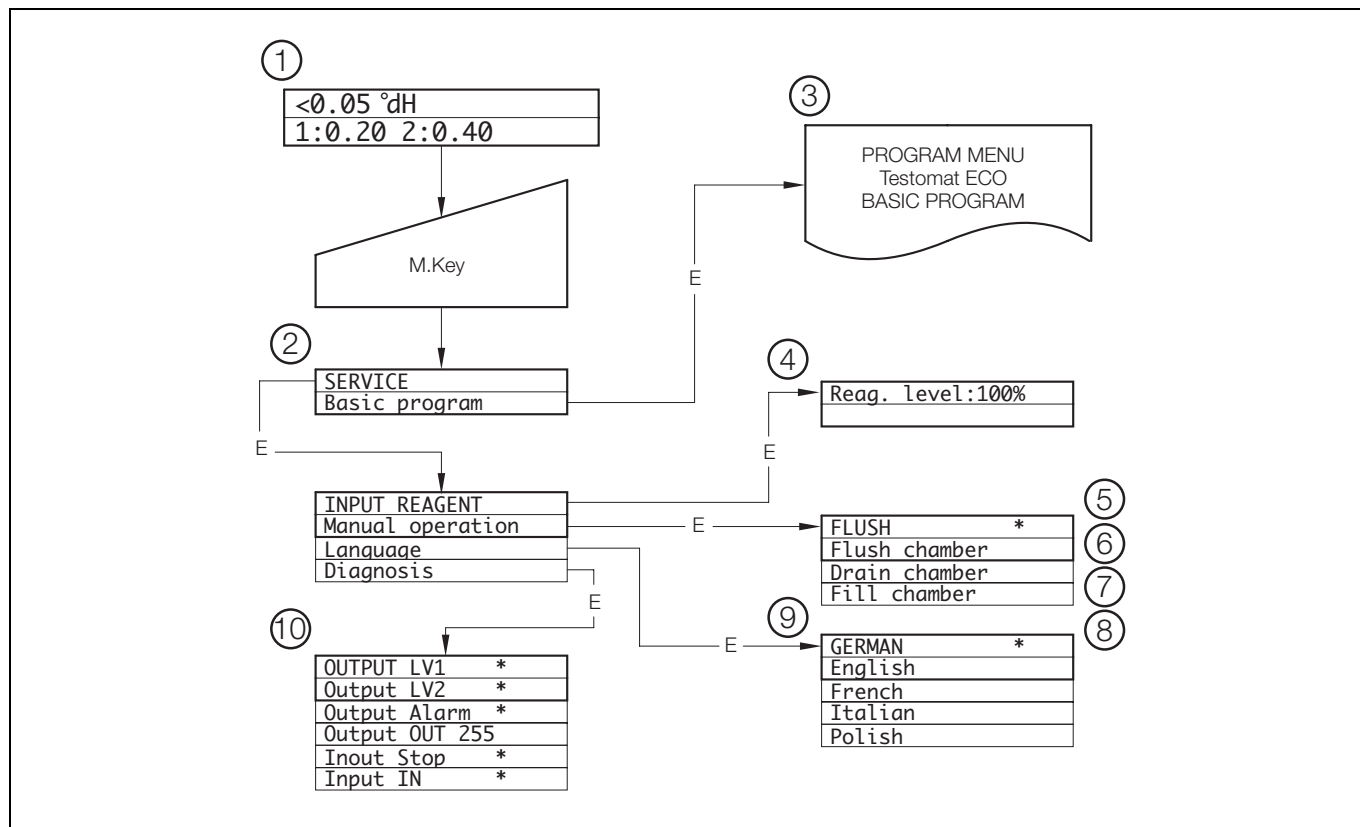

Fig. 5.3 The Program Menu

Key:

- ① Call
Press the M key to select the program menu.
Except for the basic programming, all functions without password protection can be called-up.
- ② Service
- ③ Input Reagent
After every refill or replacement of the reagent bottle or of the reagent type, enter the new level. As soon as the menu item for the filling level INPUT REAGENT (0 ... 100%) has been selected by pressing ENTER, the value is preset to 100%. If only a partially filled bottle is connected, enter the corresponding % value. When a full bottle is connected, confirm this value by pressing ENTER.
- ④ Manual Operation
After the information message (4) is confirmed by pressing ENTER, select the desired function using the arrow keys and then activate them by pressing ENTER.
These functions are used only for monitoring the operation and for commissioning.
Manual functions can be selected only during an interval between two analyses. During manual operation, no analysis is carried out. All signal inputs and outputs are held.
- ⑤ Flush
Start the flushing of the sampling tube through the internal valve by pressing ENTER. When ENTER is pressed again, this function is terminated.
- ⑥ Flush chamber
By pressing ENTER, the measuring chamber is flushed once.
- ⑦ Drain chamber
By pressing ENTER you open the outlet valve to drain the water from the measuring chamber.
By pressing the ENTER key again, this function is terminated.
- ⑧ Fill chamber
When ENTER is pressed, the measuring chamber is filled.
- ⑨ Language
Choose language of display.
- ⑩ Diagnosis
The current status of the signal inputs and outputs from a list can be called-up.
An active status is marked with a * (see menu structure).
The displayed value of the output OUT corresponds to 1/10 mA (for example, 150 = 15.0 mA).

5.7 Basic Program

After the menu has been accessed with ENTER, carry out the BASIC PROGRAMMING of the unit.

Values and settings are described in the structure of the basic program.

5.8 Program Values

To call up the factory-set basic default setting, hold down the M and i keys briefly while switching the unit ON.

5.8.1 Structure of the Basic Programming

Abbreviations: s = seconds m = minutes, h = hours, d = days, l = liters

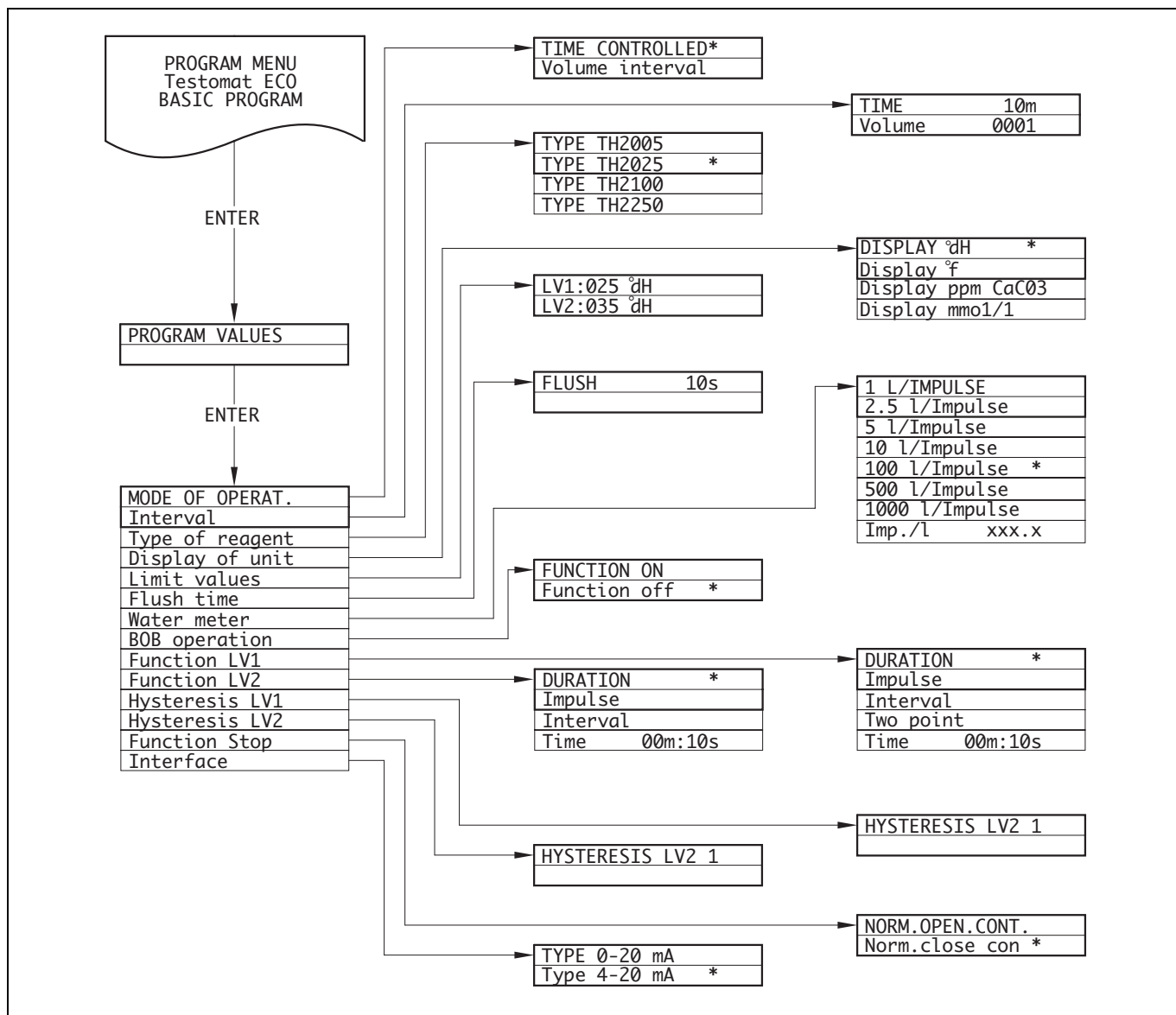

Fig. 5.4 Basic Programming Structure

Caution. To reset the factory-set basic default setting, hold down the M and i keys briefly while switching the unit ON. The previous configuration is erased.

6 Error Messages and Troubleshooting

Displayed Message (flashes at selected display) CANCEL WITH HORN-KEY	Possible Causes	Remedies
Ff. DOSING PUMP	Dosing pump defective No dosing message from the dosing pump	Replace dosing pump Check cable to the dosing pump for correct connection
Mf. TURBID	The water is turbid / dirty	
MEASURING RANGE EXCEEDED	The measuring range is exceeded	Choose another type of reagent (Basic program)
LOW WATER-PRESSURE	No water input although LED I is lit Inlet pressure too low Overflow reagent is not active	Check water inlet Connector of the inlet valve oxidized Clean filter strainer Replace valve block Extract pressure regulator valve Carry out adjustment
Ff. OUTLET TO DRAIN	Water remains in the measuring chamber although LED OUT lights up	Check water outlet Connector of the outlet valve oxidized Replace valve block
REAGENT LOW	Reagent quantity is below minimum setting without BOB: 50 ml (10%), with BOB: after calculation	Check reagent level, fill up if necessary: enter level: M ► SERVICE
Mf. DIRTINESS	Sight-glass windows dirty	Clean sight-glass windows
Ff. OPTICS	Plug-in circuit board defective Error at the optic component (transmitter or receiver defective)	Replace plug-in circuit board Replace measuring chamber sealing rings
Mf. ANALYSIS	Incorrect analysis For example: <ul style="list-style-type: none"> ■ Air in the dosing capillary ■ Incomplete blending ■ Reagent too old or use of third-party reagent 	Tighten connections of the dosing pump Replace stirring mechanism Replace suction insert in the bottle Replace reagent (use only ABB reagent)
Ff. DOSING FAULT	Dosing inaccuracy of the dosing pump	Replace dosing pump or return to the supplier for calibration

Table 6.1 Error Messages and Troubleshooting

Key

Ff. = Function fault

Mf. = Measuring fault

BOB = Low-level reagent alarm – see section 4.13, page 10.

7 Further Information

Fault	Possible causes	Remedies
Interface works incorrectly	Incorrect measuring value at the output or no power supply	Max. load exceeded
Although unit is switched ON, No display	Fuse F9, F5 or F2 (240 V: F1) defective	Replace fuses
	Power switch defective	Replace power switch
	Multi-pin strap cable at display circuit board or base circuit board loose contact	Check and reconnect
	Fault on display circuit board or base circuit board	Replace display or base circuit board

8 Maintenance

Regular maintenance is necessary in order to ensure trouble-free operation of the unit.

Please carry out the maintenance work described in the following section when:

- the programmed maintenance date has been reached (display maintenance date exceeded)
- the unit displays the error messages: MF.DIRTINESS or REAGENT LOW
- the last maintenance was carried out more than 6 months ago.

Note. Never use organic solvents to clean the measuring chamber and other plastic parts!

Observe the safety rules when handling cleaning agents.

If the measuring range has been exceeded over an extended period, a colored coating can form on the sight-glass windows. This stubborn coating can be removed easily with alcohol.

8.1 Description of Maintenance Work

Cleaning the measuring chamber and the sight-glass windows:

1. Switch the unit 'off' or press the STANDBY key (drain the measuring chamber completely).
2. Close the hand-operated valve on the sample line to the AW101.
3. Unhook the toggle-type fastener, tip the measuring chamber upwards and extract.
4. Slacken both sight-glass window holders, extract and clean the sight-glass windows. Stubborn coatings can be removed easily with alcohol.
5. Clean the measuring chamber with 10% hydrochloric acid and then rinse well.
6. After cleaning, replace the sight-glass windows and secure these with the sight-glass windows holder (do not forget the O-ring seals and check for correct seating in the recess).
7. Insert the measuring chamber by tilting it backwards until the slot engages with the rear guide bar and press down.
8. Secure the chamber with the toggle type fastener.

8.2 Cleaning the Filter Housing



Check the unit for leaks before carrying out the first analysis:

1. Switch the unit to STANDBY
2. Manually fill the measuring chamber
3. Manual reagent dosing (key Manual)
4. Check the connections and seals for leaks

Note.

Care for the unit:

- Avoid contact of the housing surface with reagent, oil or grease.
- If the housing is contaminated, clean the surface with isopropanol (never use other solvents).

To clean the filter housing:

1. Close the hand-operated valve on the sample line to the AW101.
2. Undo the hose connections to the filter housing.
3. Unscrew the inlet connection, remove sealing ring, spring and filter strainer. Clean these items.
4. Extract the retaining pin and withdraw the flow regulator and remove the valve body.
5. Clean the filter housing with water or alcohol and reassemble.

Note. Insert the filter strainer with pointed end downwards.

6. Install the hose connections to the filter housing.

Water leakage from the seals can result in damage to parts of the unit

9 Spare Parts List

Pressure Regulator

AW101601	Regulator/Filter housing
AW101602	Regulator plug T2000, kpl
AW101603	Flow regulator valve
AW101604	Retaining pin for regulator plug
AW101605	Inlet filter
AW101606	Spring for inlet filter
AW101607	Inlet connector
AW101608	Plug-in connector

Measuring Chamber

AW101611	Sight-glass window 30 x 3 with seal
AW101612	Sight-glass window 30 x 3
AW101613	Sight-glass retaining disc
AW101614	Screw spindle M3 x 40
AW101615	Latch fastener TL 800-7-1
AW101616	Plastic plug
AW101617	Measuring chamber T2000

Holding Block for Measuring Chamber

AW101622	Magnetic stirrer
AW101623	Plug-in connector – G3/8 in.
AW101624	Solenoid valve 2/2–way
AW101625	Rear guide bar for measuring chamber

Dosing Pump DOSI Clip

AW101631	Jet pump complete
AW101632	Suction capillary
AW101633	Pressure capillary complete
AW101634	Base circuit board T1 complete
AW101635	Magnet (24 V DC)

Bottle Connections/Suction Tube

AW101641	Screwed cap with bottle insert T2000
AW101642	Screwed cap GL32 only
AW101643	Bottle insert for screwed cap with push–fit suction

Electrical Components

AW101651	Fuse M4A
AW101656	Cable sleeve 7 – 10
AW101657	Mains on/off switch
AW101658	Cover for mains on/off switch
AW101659	Multi-pin strap cable 10 pole with EMI filter clamp
AW101660	Multi-pin strap cable 26 pole with EMI filter clamp
AW101661	Cable loom 2V complete (for valves)
AW101663	Cable loom for mains on/off switch complete
AW101664	Fuse T0.16 A
AW101665	Fuse T1.0 A

Spare Parts for 2 to 3 Years Operation

AW101611	2 x sight-glass window 30 x 3 with seal
AW101605	1 x inlet filter (optional)
AW101701	Gasket set T2000. The quantity required is dependent on the maintenance regime (see section 8.2, page 16)
AW101664	1 x fuse T0.16 A
AW101665	1 x fuse T1.0 A
AW101901	TH2005 Water Hardness 0.89 to 8.93 ppm CaCO ₃
AW101902	TH2025 Water Hardness 4.47 to 44.7 ppm CaCO ₃
AW101903	TH2100 Water Hardness 17.9 to 179 ppm CaCO ₃
AW101904	TH2250 Water Hardness 44.7 to 447 ppm CaCO ₃

10 AW101 Testomat® Block Diagram

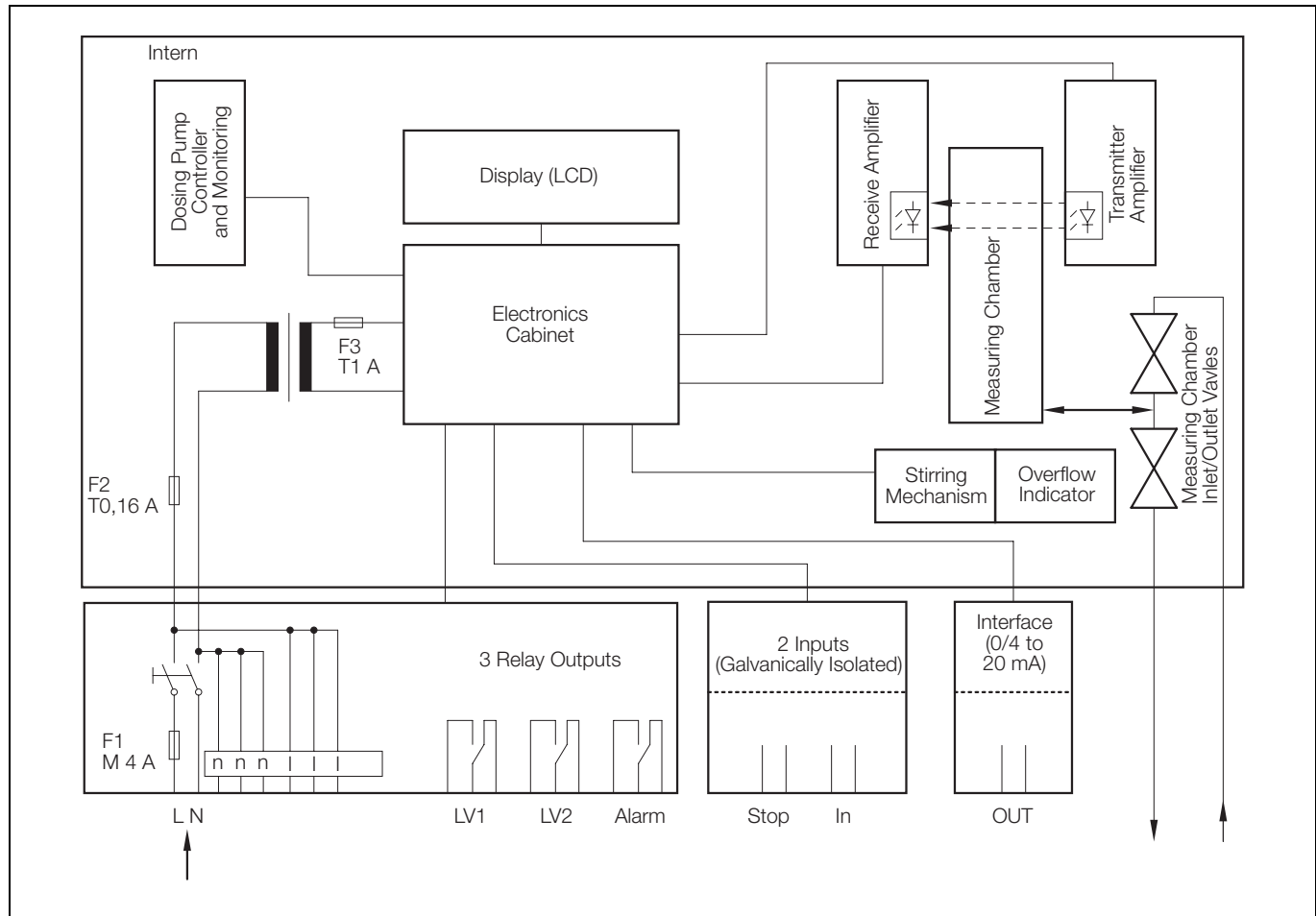

Fig. 10.1 AW101 Testomat® Block Diagram

10.1 Terminal Block Identification

No.	Terminal	Type	Function	Note
-	PE	IN	Mains – Protective earth (5x)	Earth/Ground
1 2	L N	IN	Mains, L = Live Mains, N = Neutral	Mains input 115 V, 230 V or 24 V AC
3 to 5 6 to 8	n l	OUT	Neutral, switched (8x) Live, switched (8x)	Mains voltage, max. 4 A
9 10 11	LV1	OUT	Limit value output 1 – Normally closed Limit value output 1 – Common Limit value output 1 – Normally open	Volt-free relay output, max. load 240 V AC, 4 A
12 13 14	LV2	OUT	Limit value output 2 – Normally closed Limit value output 2 – Common Limit value output 2 – Normally open	Volt-free relay output, max. load 240 V AC, 4 A
15 16 17	Alarm	OUT	Fault message – Normally closed Fault message – Common Fault message – Normally open	Volt-free relay output, max. load 240 V AC, 4 A
18 19	Stop 2	IN	External analysis stop Common earth for inputs	Only for volt-free normally open/normally closed contact
20 21	IN 2	IN	Water meter input Common earth for inputs	Only for volt-free normally open/normally closed contact Note technical data of turbine
22 23	OUT + OUT -	OUT	0 or 4 to 20mA	Current output 22 + (0/4 to 20 mA) 23 -
24	+	OUT	+12 V for Hall-Sensor (turbine)	Note technical data of turbine. Max. power input of sensor must not exceed 20 mA

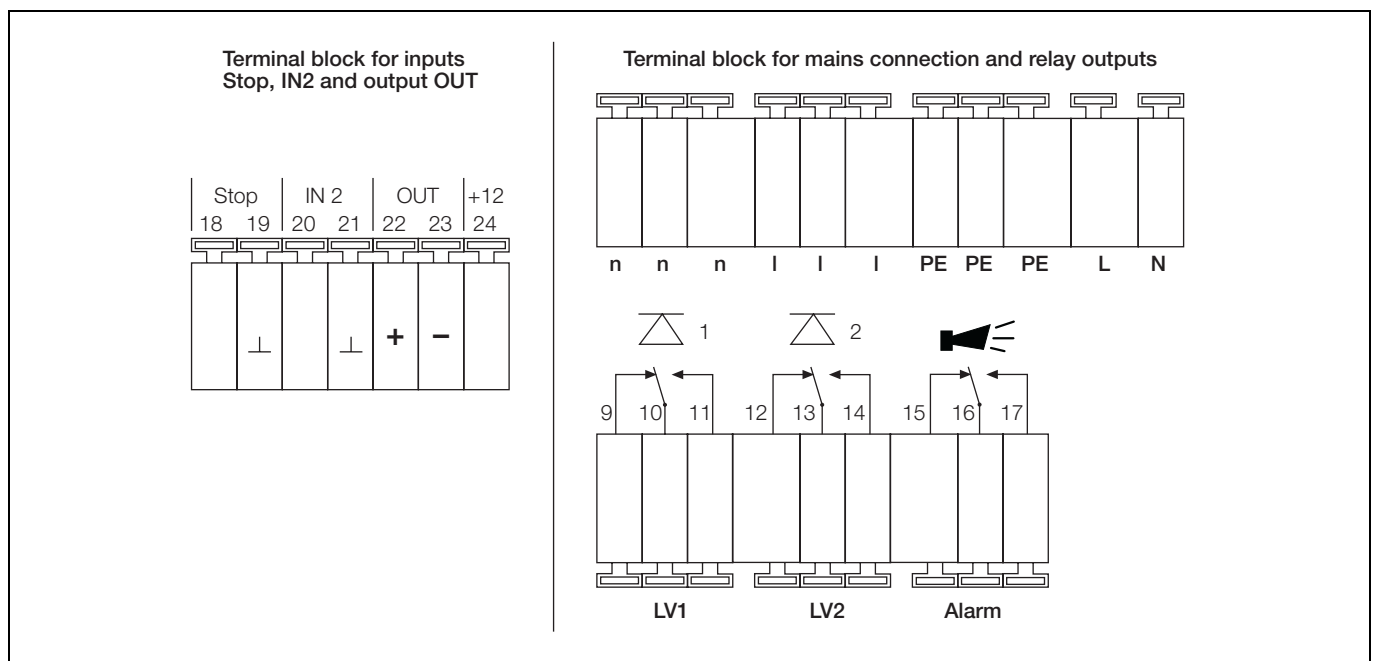

Fig. 10.2 Terminal Block Labels

11 Specification

Ranges

Determined by reagent – see Table 1.1 on page 2)

Alarms

Three relay outputs –

Limit values (LV1, LV2) and one fault alarm

Resistive load 4 A

Alarm displays

The following faults are shown on the display and also activate the Alarm output:

- Low water pressure
- Function fault optics
- Measuring fault analysis
- Function fault dosing pump
- Function fault outlet to drain
- Reagent low level
- Measuring fault dirtiness
- Measuring fault turbine meter
- Measuring range exceeded

Front panel indicators

Programme in operation

Analysis stopped

Lack of reagent

Satisfactory result

Unsatisfactory result

Viewing window

Outputs

Current output

0 to 20 mA or 4 to 20 mA

Max. load 500 Ω

EMC

Conformity

EN50081-1, EN5008-2, EN61010-1

Power Supply

Voltage

115 V, 230 V or 24 V AC \pm 10%, 50/60 Hz

Power consumption

30 VA

Unit Protection

115 V, 230 V: T 0.1 A

24 V:T 1.0 A

Environmental Data

Sample pressure

0.1 to 3 bar (1.5 to 45.5 psi)

Sample temperature

10 to 40 °C (41 to 104 °F) max.

Ambient temperature

10 to 45 °C (41 to 124 °F)

Mechanical Data

Ingress protection

IP65

Dimensions

380 x 459 x 280 mm (15 x 18.8 x 11 in.)

Weight

9 kg (19.8 lbs)

Consumables

Reagent consumption

0.07ml (0.000123 pint) per test

SS/AW101 Issue 3

PRODUCTS & CUSTOMER SUPPORT

Products

Automation Systems

- for the following industries:
 - Chemical & Pharmaceutical
 - Food & Beverage
 - Manufacturing
 - Metals and Minerals
 - Oil, Gas & Petrochemical
 - Pulp and Paper

Drives and Motors

- AC and DC Drives, AC and DC Machines, AC Motors to 1kV
- Drive Systems
- Force Measurement
- Servo Drives

Controllers & Recorders

- Single and Multi-loop Controllers
- Circular Chart and Strip Chart Recorders
- Paperless Recorders
- Process Indicators

Flexible Automation

- Industrial Robots and Robot Systems

Flow Measurement

- Electromagnetic Flowmeters
- Mass Flowmeters
- Turbine Flowmeters
- Wedge Flow Elements

Marine Systems & Turbochargers

- Electrical Systems
- Marine Equipment
- Offshore Retrofit and Refurbishment

Process Analytics

- Process Gas Analysis
- Systems Integration

Transmitters

- Pressure
- Temperature
- Level
- Interface Modules

Valves, Actuators and Positioners

- Control Valves
- Actuators
- Positioners

Water, Gas & Industrial Analytics Instrumentation

- pH, Conductivity and Dissolved Oxygen Transmitters and Sensors
- Ammonia, Nitrate, Phosphate, Silica, Sodium, Chloride, Fluoride, Dissolved Oxygen and Hydrazine Analyzers
- Zirconia Oxygen Analyzers, Katharometers, Hydrogen Purity and Purge-gas Monitors, Thermal Conductivity

Customer Support

We provide a comprehensive after sales service via a Worldwide Service Organization. Contact one of the following offices for details on your nearest Service and Repair Centre.

UK

ABB Limited
Tel: +44 (0)1453 826661
Fax: +44 (0)1453 829671

USA

ABB Inc.
Tel: +1 215 674 6000
Fax: +1 215 674 7183

Client Warranty

Prior to installation, the equipment referred to in this manual must be stored in a clean, dry environment, in accordance with the Company's published specification.

Periodic checks must be made on the equipment's condition. In the event of a failure under warranty, the following documentation must be provided as substantiation:

1. A listing evidencing process operation and alarm logs at time of failure.
2. Copies of all storage, installation, operating and maintenance records relating to the alleged faulty unit.

ABB has Sales & Customer Support expertise
in over 100 countries worldwide

www.abb.com

The Company's policy is one of continuous product
improvement and the right is reserved to modify the
information contained herein without notice.

Printed in UK (06.08)

© ABB 2008



ABB Limited
Oldends Lane, Stonehouse
Gloucestershire
GL10 3TA
UK
Tel: +44 (0)1453 826661
Fax: +44 (0)1453 829671

ABB Inc.
125 E. County Line Road
Warminster
PA 18974
USA
Tel: +1 215 674 6000
Fax: +1 215 674 7183