



# ABB

## The Company

We are an established world force in the design and manufacture of instrumentation for industrial process control, flow measurement, gas and liquid analysis and environmental applications.

As a part of ABB, a world leader in process automation technology, we offer customers application expertise, service and support worldwide.

We are committed to teamwork, high quality manufacturing, advanced technology and unrivalled service and support.

The quality, accuracy and performance of the Company's products result from over 100 years experience, combined with a continuous program of innovative design and development to incorporate the latest technology.

The UKAS Calibration Laboratory No. 0255 is just one of the ten flow calibration plants operated by the Company and is indicative of our dedication to quality and accuracy.

EN ISO 9001:2000



Cert. No. Q 05907

EN 29001 (ISO 9001)



Lenno, Italy – Cert. No. 9/90A

Stonehouse, U.K.



0255

## Electrical Safety

This equipment complies with the requirements of CEI/IEC 61010-1:2001-2 'Safety Requirements for Electrical Equipment for Measurement, Control and Laboratory Use'. If the equipment is used in a manner NOT specified by the Company, the protection provided by the equipment may be impaired.

## Symbols

One or more of the following symbols may appear on the equipment labelling:

	<b>Warning</b> – Refer to the manual for instructions		Direct current supply only
	<b>Caution</b> – Risk of electric shock		Alternating current supply only
	Protective earth (ground) terminal		Both direct and alternating current supply
	Earth (ground) terminal		The equipment is protected through double insulation

Information in this manual is intended only to assist our customers in the efficient operation of our equipment. Use of this manual for any other purpose is specifically prohibited and its contents are not to be reproduced in full or part without prior approval of the Technical Publications Department.

### Health and Safety

To ensure that our products are safe and without risk to health, the following points must be noted:

1. The relevant sections of these instructions must be read carefully before proceeding.
2. Warning labels on containers and packages must be observed.
3. Installation, operation, maintenance and servicing must only be carried out by suitably trained personnel and in accordance with the information given.
4. Normal safety precautions must be taken to avoid the possibility of an accident occurring when operating in conditions of high pressure and/or temperature.
5. Chemicals must be stored away from heat, protected from temperature extremes and powders kept dry. Normal safe handling procedures must be used.
6. When disposing of chemicals ensure that no two chemicals are mixed.

Safety advice concerning the use of the equipment described in this manual or any relevant hazard data sheets (where applicable) may be obtained from the Company address on the back cover, together with servicing and spares information.

---

# CONTENTS

---

Section	Page
<b>1 INTRODUCTION .....</b>	<b>2</b>
<b>2 PREPARATION .....</b>	<b>2</b>
2.1 Company Standard Settings .....	2
<b>3 INSTALLATION .....</b>	<b>3</b>
3.1 Serial Communication Adaptors for Personal Computers .....	3
3.1.1 Configuration .....	3
<b>4 ELECTRICAL CONNECTIONS .....</b>	<b>3</b>
4.1 Serial Connections .....	3
4.1.1 Cabling .....	3
<b>5 SETTING UP .....</b>	<b>4</b>
5.1 Termination Resistors .....	4
<b>6 PROTOCOL .....</b>	<b>4</b>
<b>7 PROGRAMMING .....</b>	<b>5</b>
7.1 Serial Interface Page .....	5
<b>8 COMMUNICATION .....</b>	<b>6</b>
8.1 Communication between Master and Slaves .....	6
8.1.1 Mnemonics .....	6
8.2 Command Format .....	6
8.2.1 Term Clarification for Command Format .....	6
8.3 Reply Format .....	7
8.3.1 Term Clarification for Reply Format .....	7
8.4 Communication Examples .....	8
8.5 Status .....	8
8.6 Error Codes .....	9
8.7 Command Mnemonics .....	10
8.7.1 General Mnemonics .....	10
8.7.2 Multiple Read Mnemonics .....	11
<b>9 OPERATION .....</b>	<b>12</b>
<b>10 SPECIFICATION .....</b>	<b>12</b>
<b>APPENDICES .....</b>	<b>13</b>
A1 The American Standard Code for Information Interchange (ASCII) .....	13
A2 Non-volatile Memory Limitations .....	15
A3 Block Check Characters .....	15
A3.1 BCC Example .....	15

---

# 1 INTRODUCTION

---

The ZMT Series of oxygen analyzers is extended by the addition of a serial data communication option which allows addressing and reprogramming via a computer terminal or host computer.

The RS422/485 communication standard is used with the following logic levels:

- a) for logic '1' (MARK condition or IDLE state) the 'A' terminal of the transmitter is negative (0V) with respect to the 'B' terminal (+5V)
- b) for logic '0' (SPACE condition or ACTIVE state) the 'A' terminal of the transmitter is positive (+5V) with respect to the 'B' terminal (0V).

**Note.** 'A' terminal is Tx + or Rx + and 'B' terminal is Tx – or Rx –.

Parity is used for simple error checking. The parity bit is a one-bit code which is transmitted in addition to the ASCII character. It can detect only one error per character, since two errors may cancel out. Parity is calculated by finding the sum of logic '1's in the character and either:

- a) setting the parity bit to logic '1' if the sum is odd, or logic '0' if the sum is even, when using even parity
- or
- b) setting the parity bit to logic '0' if the sum is odd, or logic '1' if the sum is even, when using odd parity.

The block check character (BCC) is an additional form of checking and is the arithmetic sum of all the characters in a complete message (excluding parity bits) – see Appendix A3. Error detection is achieved by comparison of the BCC's of the transmitted and received messages.

This manual must be read in conjunction with the instrument operating instructions detailed in IM/ZMT.

---

# 2 PREPARATION

---

The procedure is similar to that described in the Operating Instructions (IM/ZMT) with additions as detailed in this section.

## 2.1 Company Standard Settings

Only those parameters detailed on the customer order are programmed at the factory. If any parameters are unsuitable for the application they can be reprogrammed – see Section 9 of the Operating Instructions (IM/ZMT). Serial data programming procedures are detailed in Section 7 of this manual.

Standard parameter settings for the serial data programme are as follows:

<b>Instrument Identity</b>	01
<b>Parity</b>	None
<b>Block Check Character (BCC)</b>	BCC off
<b>Transmission Rate</b>	9600 baud.

Observe the limitations outlined in the Operating Instructions (IM/ZMT). The maximum serial data transmission line length for both RS422 and RS485 systems is 1200m.

### 3 INSTALLATION

#### 3.1 Serial Communication Adaptors for Personal Computers

An RS422/485 communications adaptor board is required for serial links. It is strongly recommended that the card used has galvanic isolation to protect the computer from lightning damage and increase immunity from noise pick-up from cables.

##### 3.1.1 Configuration

The following OPTO22 boards are recommended for use with the serial version of ZMT analyzers:

Part No.	Computer Type
AC24	XT Bus IBM PC compatible
AC24 AT	AT Bus IBM PC compatible
AC34	Microchannel IBM PC.

The following 'Jumper' selections are required on OPTO22 boards (usually supplied as the default configuration):

<b>RX &amp; TX</b>	install line termination jumper Install pull-up and pull-down jumpers
<b>CTS &amp; RTS</b>	disable jumper installed.

Select board address and interrupts as described in the OPTO22 manual.

### 4 ELECTRICAL CONNECTIONS

All connections, apart from those for serial data communication, are made as shown in Figs. 5.4 and 5.5 of the Operating Instructions (IM/ZMT).

#### 4.1 Serial Connections – Figs. 4.1 and 4.2

The transmitters must be connected in parallel as shown in the schematic diagram – Fig. 4.1. The RS485 standard quotes connection of maximum thirty two slaves (ZMT Analyzers) to any single driver (computer terminal or host computer); the RS422 standard quotes connection of up to ten slaves. However, these numbers can be increased if the driver's serial port permits.

Make serial data connections as shown in Fig. 4.2. The type of cable used is dependent on the transmission speed and cable length:

##### 4.1.1 Cabling (refer also to Fig. 9.1 on page 13)

**Up to 6m (all speeds)** – standard screened or twisted pair cable.

**Up to 300m** – twin twisted pair with overall foil screen and an integral drain wire, e.g. Belden 9502 or equivalent

**Up to 1200m** – twin twisted pair with separate foil screens and integral drain wires for each pair, e.g. Belden 9729 or equivalent

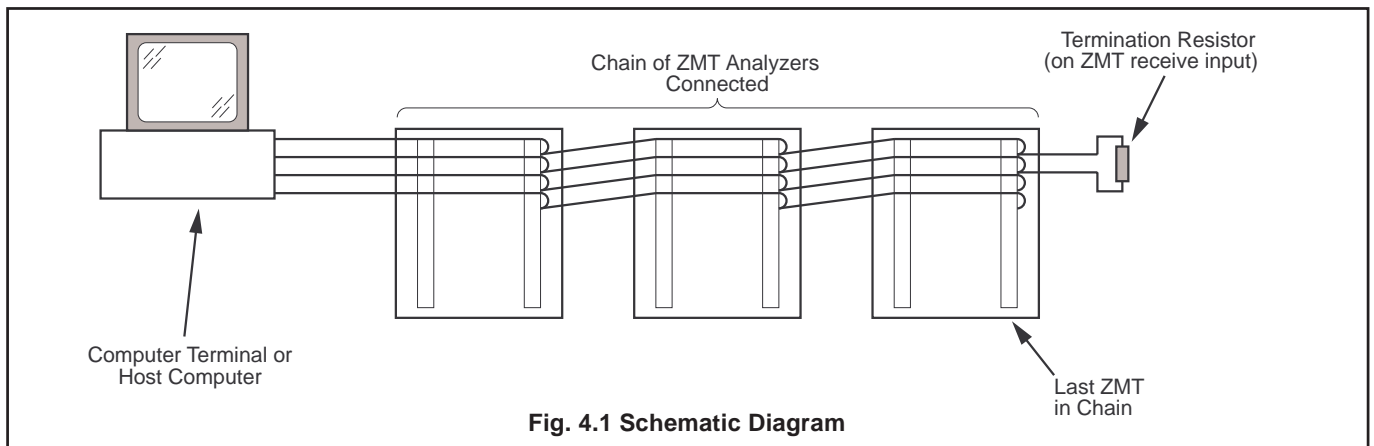

Fig. 4.1 Schematic Diagram

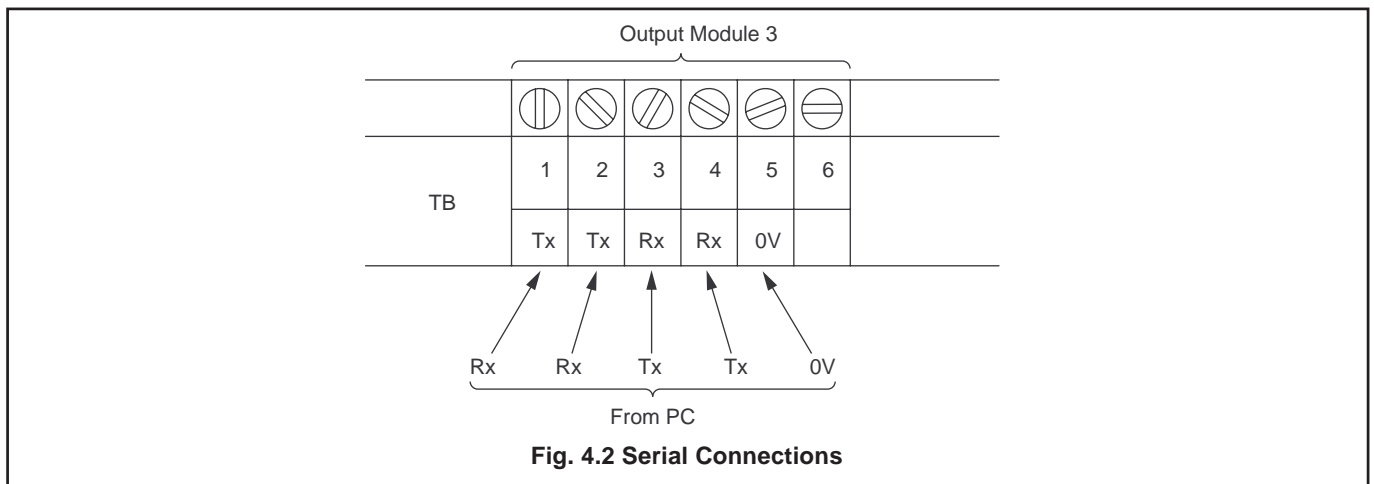

Fig. 4.2 Serial Connections

## 5 SETTING UP

For all aspects other than serial data transmission the transmitter is set up as shown in the Operating Instructions (IM/ZMT). Unless otherwise requested, the instrument is despatched with a transmission rate of 9600 baud and transmission line termination resistors linked-out. If these settings are unsuitable, refer to Section 5.1.

### 5.1 Termination Resistors and Baud Rate Settings – Fig. 5.1

#### 5.1.1 Termination Resistors

For long transmission lines, termination resistors are required on the last ZMT Analyzer in the chain and at the host computer/computer terminal. Under normal operating conditions the resistors are required at the last ZMT receive inputs only – see Fig. 4.1. The analyzer's resistors are selected using plug-in links – see Fig. 5.1.

Switch off the supply and gain access to the Serial Output board in Output Module 3 – see *IM/ZMT, Section 6.2*. Set the termination resistor links as shown in Fig. 5.1.

#### 5.1.2 Hardware Baud Rate Setting

To set the Baud rate to the required speed, set the plug-in link as shown in Fig. 5.1

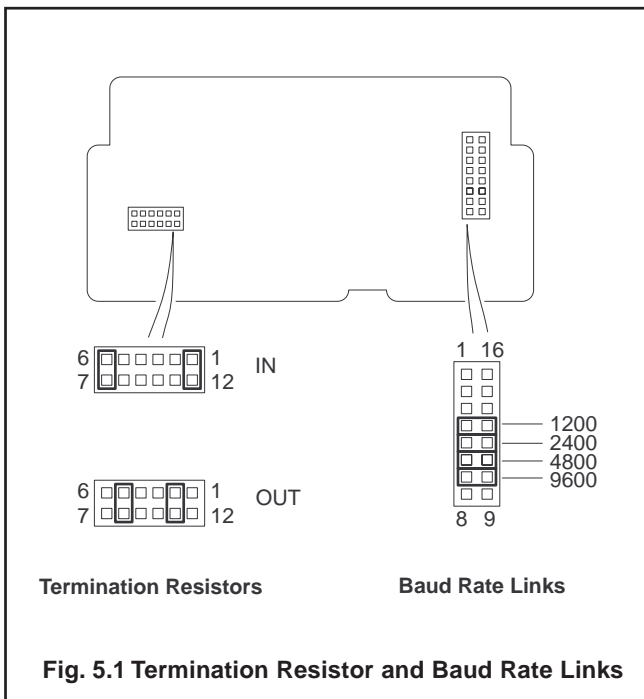

## 6 PROTOCOL

The protocol used is based on ANSI-X3.28-1976-2.5-A4 and is used for master (host computer) to slave (ZMT Analyzer) systems. This is the **recommended protocol for use with supervisory systems** such as ABB Kent-Taylor PC30. The Protocol is:

Start transmission (STX) – Command – Identification...  
...End transmission (ETX) – see Figs. 8.1 to 8.6.

Transmissions of commands and processing of the subsequent replies must be incorporated into the host computer programme.

# 7 PROGRAMMING

The general programming procedure is as detailed in the Operating Instructions (IM/ZMT) but with an additional **Serial Interface** page – see Fig. 7.1.

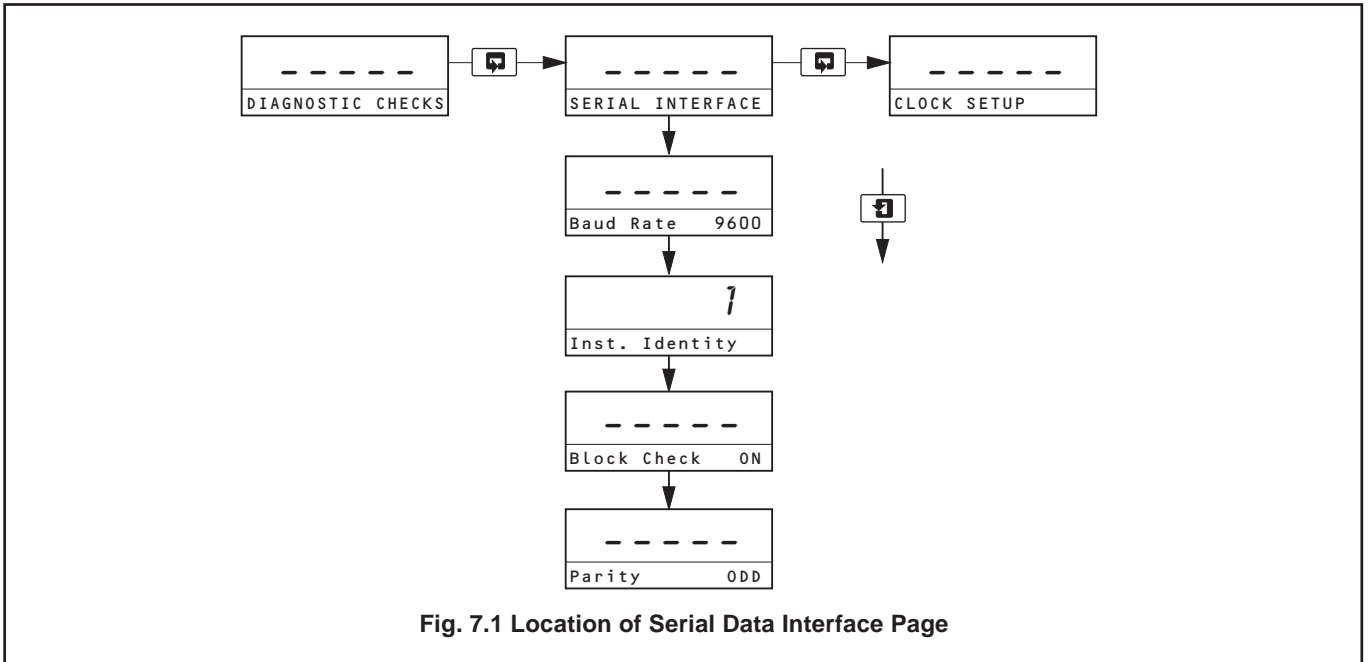
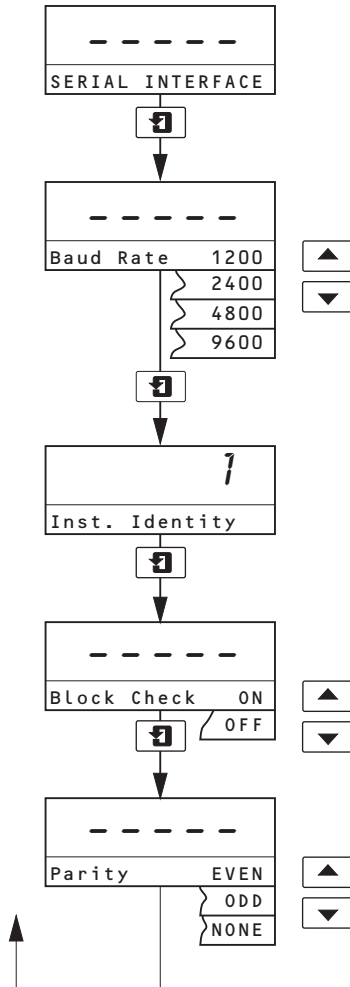

Fig. 7.1 Location of Serial Data Interface Page

## 7.1 Serial Interface Page



Page Header – **Serial Interface**

### Transmission Rate

Select the transmission (baud) rate required (1200 slowest, 9600 fastest).

**Note.** The transmission rate selected must be the same as that selected in Section 5.1.2

### Transmitter Identification

Assign the transmitter an identification number (1 to 99) – see Section 4.1. The maximum number (99) allows transmitters to be connected to more than one communication channel.

### Block Check Character

Select ON or OFF as required – see Section A3.

### Parity

Select the appropriate parity to match the computer terminal or host computer.

Return to the top of the **Serial Interface Page** or advance to the next page.

## 8 COMMUNICATION

### 8.1 Communication Between Master and Slaves

The commands from the master are coded as single characters as follows:

- R** – 'Read' (read parameters)
- M** – 'Multiple Read' (read a selection of parameters)
- W** – 'Write' (write new parameter values).

#### 8.1.1 Mnemonics

Each mnemonic for the ZMT Analyzer parameters comprises two characters – see Section 8.7.

### 8.2 Command Format – Figs. 8.1 to 8.3

The protocol is based on ANSI-X3.28-1976-2.5-A4. Entries are made directly from the host computer using the command format shown in Figs. 8.1 to 8.3.

### 8.2.1 Term Clarification for Command Format

**Start** – one ASCII control character (always 'STX') signifying the start of transmission.

**Command** – one character, R, M or W – see Section 8.1.

**Instrument Identification** – two characters identifying the ZMT Transmitter, 1 to 99.

**Parameter** – two-character mnemonic selected from Section 8.7.

**Sign** – one character:

- '+' – parameter value is positive (optional)
- '-' – parameter value is negative.

**Data** – usually up to six characters (including decimal point) used to write a new parameter value.

**Limiter** – one character (always 'ETX') signifying the end of data transmission.

**Block Check Character (BCC)** – one character, the arithmetic sum of the complete message (excluding parity bits), transmitted by the host computer for error detection – see Appendix A3.

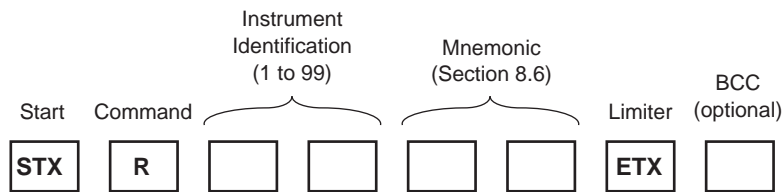

Fig. 8.1 'Read' Command Format

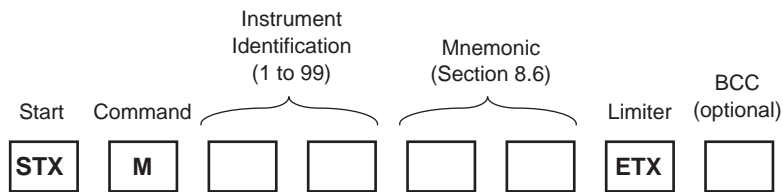

Fig. 8.2 'Multiple Read' Command Format

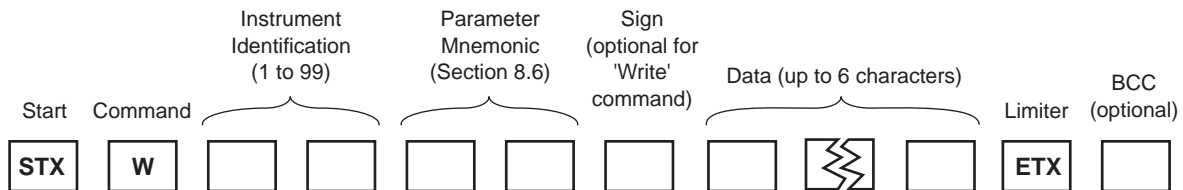

Fig. 8.3 'Write' Command Format

**8.3 Reply Format – Figs 8.4 to 8.6**

The ZMT Analyzer replies to the command using the reply format shown in Figs. 8.4 to 8.6.

**Block Check Character (BCC)** – one character, the arithmetic sum of the complete message (excluding parity bits), transmitted by the analyzer for error detection – see Appendix A3.

**8.3.1 Term Clarification for Reply Format**

**Instrument Identification** – two characters identifying the ZMT Analyzer, 1 to 99.

**Data** – usually up to six characters (including decimal point) showing the new parameter value.

**Error Code** – two-character mnemonic – see Section 8.6.

**Reply** – one ASCII control character (see Appendix A1):

- 'ACK' – command understood
- 'NAK' – command not understood
- 'ETB' – end of multiple read reply block.

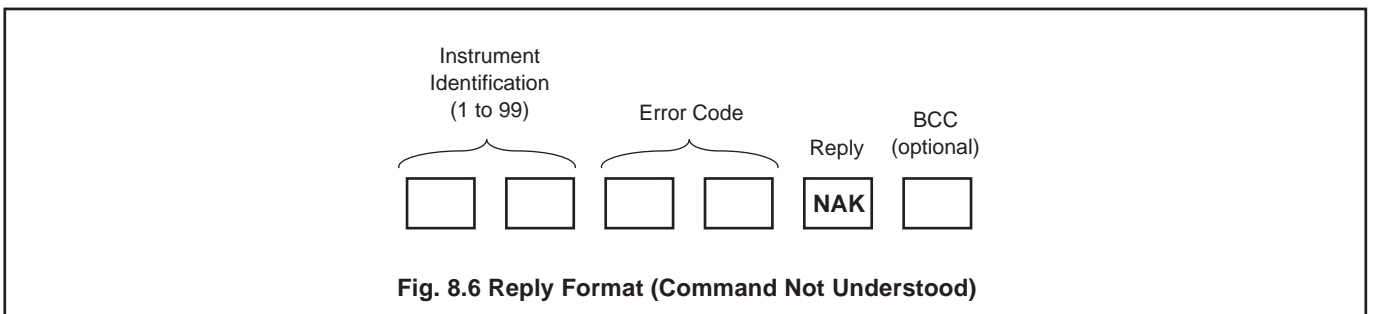
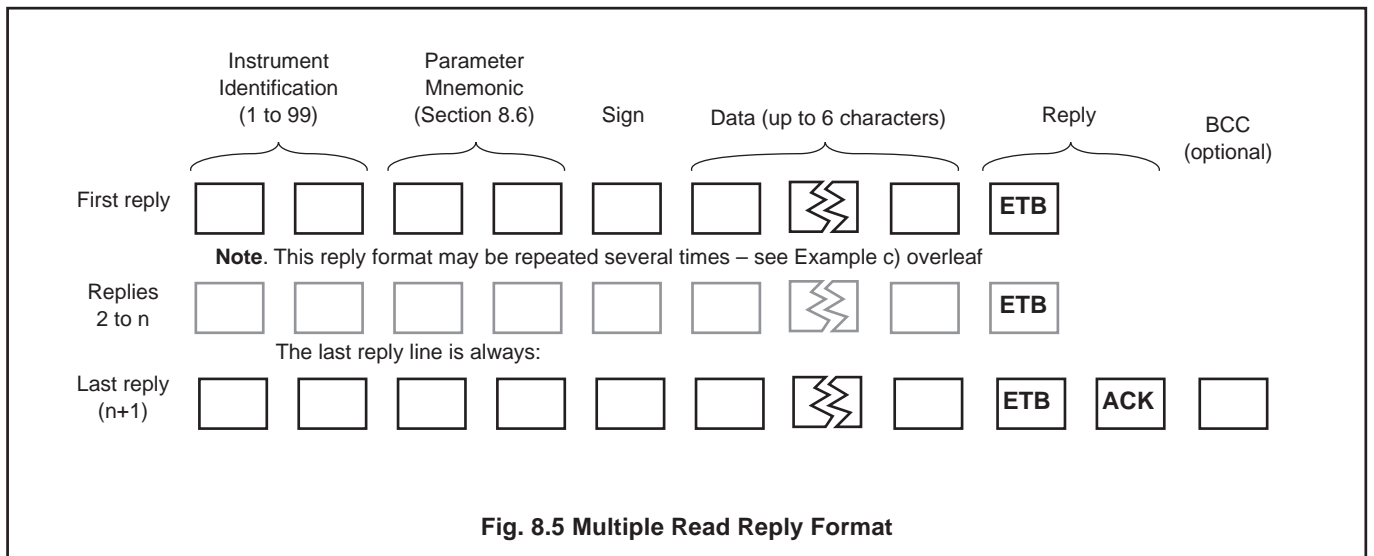
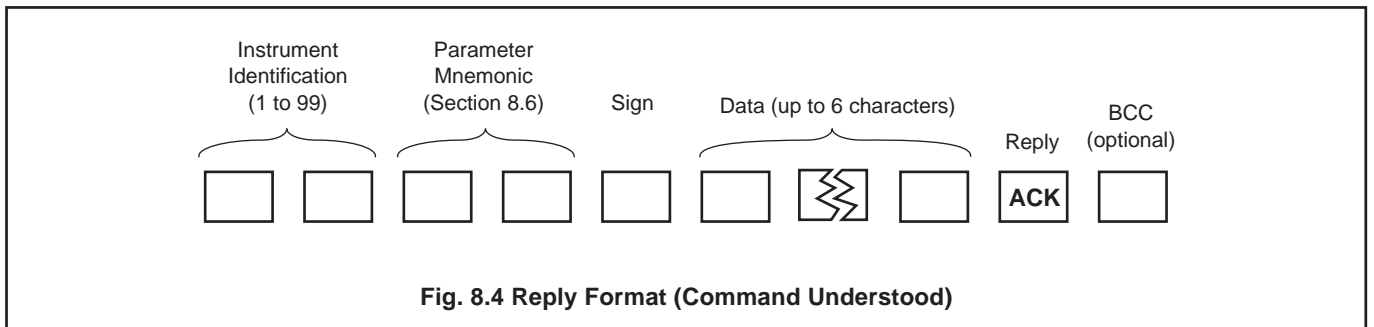

## ...8 COMMUNICATION

### 8.4 Communication Examples

The following examples show typical master-to-slave transmissions and the subsequent slave-to-master replies. For **Error Code** and **Parameter** interpretations refer to Sections 8.6 and 8.7.

#### a) Command – STX R 06 O2 ETX

STX Start of text  
R 'Read' command  
06 Analyzer number 6  
O2 Oxygen  
ETX End of transmission

#### Reply – 06 02 20.9 ACK

06 Analyzer number 6  
02 Oxygen  
20.9 Oxygen value = 20.9  
ACK Command understood

#### b) Command – STX M 06 M1 ETX

STX Start of text  
M 'Multiple Read' command  
06 Analyzer number 6  
M1 Multiple Read Mnemonic  
ETX End of transmission

#### Reply – 06 02 20.9 ETB

06 CT 700 ETB  
06 FT 200 ETB  
06 AT 20 ETB  
06 EF 98.0 ETB  
06 CO 200 ETB  
06 CD 10 ETB  
06 SA 0 ETB  
ACK  
  
06 Analyzer number 6  
02 Oxygen  
20.9 Oxygen value = 20.9  
ETB End of transmission block  
  
06 Analyzer number 6  
CT Cell temperature  
700 Cell temperature = 700  
ETB End of transmission block  
  
06 Analyzer number 6  
FT Flue temperature  
200 Flue temperature = 200  
ETB End of transmission block  
  
06 Analyzer number 6  
AT Air temperature  
20 Air temperature = 20  
ETB End of transmission block  
  
06 Analyzer number 6  
EF Efficiency  
98.0 Efficiency value = 98.0  
ETB End of transmission block  
  
06 Analyzer number 6  
CO Carbon Monoxide  
200 Carbon Monoxide value = 200  
ETB End of transmission block  
  
06 Analyzer number 6  
CD Carbon Dioxide  
10 Carbon Dioxide value = 10  
ETB End of transmission block  
  
06 Analyzer number 6  
SA Status  
0 Status = No Alarms  
ETB End of transmission block  
  
ACK Command understood

#### c) Command – STX W 06 DA ETX

STX Start of text  
W 'Write' command  
06 Analyzer number 6  
DA Carry out auto calibration  
ETX End of transmission

#### Reply – 06 DA 01 ACK

06 Analyzer number 6  
DA Carry out auto calibration  
01 Auto calibration status  
(01 – Yes, 00 – No)  
ACK Command understood

### 8.5 Status

The status code is assigned to any alarm conditions which may be present.

#### Status code Description

00	No Alarms (highest priority)	08	Cell low temperature
01	Cell Thermocouple reversed	09	Cell high temperature
02	Cell Thermocouple broken	10	Flue high temperature
03	Cell warming up	11	Flue low temperature
04	Cell stabilizing	12	Oxygen 1 alarm
05	Cell under temperature	13	Oxygen 2 alarm
06	Flue Thermocouple broken	14	Auto Cal pass/fail
07	Air Thermocouple broken	15	In auto cal
<b>Status code</b>	<b>Description</b>	16	Cell at temperature (lowest priority)

### 8.6 Error Codes

## 8.7 Command Mnemonics

Error Code	Error
01	Invalid command – the received command was not R (read), W (write) or M (multiple read).
02	Invalid 'Read' parameter – parameter cannot be used with Read command.
03	Invalid 'Write' parameter – parameter cannot be used with Write command.
04	Too many characters entered into buffer – received message length is greater than 32 characters.
05	Invalid decimal point position.
08	The 'Write' value is not within the controllers limits.
10	Non-numeric character entered in data.
15	Received block check character error.
16	No STX character in complex format.
17	Received parity check error.
18	Overrun or framing error detected in received data.
19	Error in Multiple read command.
20	No data in 'Write' command.
21	More than one decimal point in data.
22	No data after decimal point in data.
23	More than six characters in data field.
26	Invalid characters in 'Read' command.

## ..8 COMMUNICATION

**Information.** In the following Sections:

- All parameters can be 'Read'.
- Some parameters can be written to ('Write' Command) – see Sections 8.7.1.
- Some parameters can be read as a group ('Multiple' Read) – see Section 8.7.2.

### 8.7.1 General Mnemonics

Parameter	Mnemonic	Write	Interpretation
% Oxygen	O2	No	Displayed Oxygen value
Cell Temperature	CT	No	Displayed Cell Temperature
Flue Temperature	FT	No	Displayed Flue Temperature
Air Temperature	AT	No	Displayed Air Temperature
Efficiency	EF	No	Displayed Efficiency
Carbon Monoxide	CO	No	Displayed Carbon Monoxide
Carbon Dioxide	CD	No	Displayed Carbon Dioxide
Instrument Status	SA	No	Instrument Status
Relay 1 Action	RA	No	Energised above or below set point
Relay 1 On/Off	RO	No	0 – Off 1 – On
Relay 1 Type	RT	No	0 – % Oxygen 1 1 – % Oxygen 2 2 – Fuel 1/ Fuel 2 3 – Cell under temperature 4 – Any Thermocouple broken 5 – Cell Thermocouple broken 6 – Flue Thermocouple broken 7 – Air Thermocouple broken 8 – Cell Temperature high 9 – Cell Temperature low 10 – Flue Temperature high 11 – Flue Temperature low 12 – General alarm
Cell Constant	CC	No	mV value of cell constant
Slope	SL	No	Slope % of theory (0.0% to 100%)
Current Output Type	TA	No	0 – % Oxygen 1 – Cell Temperature 2 – Flue Temperature 3 – Air Temperature 4 – Efficiency
Current Output Range Zero	AZ	No	0.0 to 25.0%
Current Output Range Span	AS	No	0.0 to 25.0%
Current Output On/Off Status	AO	No	0 – Off 1 – On
Auto Cal Zero Status	S4	No	0 – Passed 1 – Unstable 2 – > ± 30mV
Auto Cal Span Status	S3	No	0 – Passed 1 – Unstable 2 – > ± 10%
Relay 1 Set point	R1	Yes	Relay 1 O2 Set point
Do Auto Cal	DA	Yes	0 – No 1 – Yes
Auto Cal Type	TY	Yes	0 – None 1 – Zero 2 – Span 3 – Zero and Span

**8.7.2 Multiple Read Mnemonics**

<b>Parameter</b>	<b>Mnemonic</b>	<b>Write</b>	<b>Interpretation</b>
% Oxygen	O2	No	Displayed Oxygen value
Cell Temperature	CT	No	Displayed Cell Temperature
Flue Temperature	FT	No	Displayed Flue Temperature
Air Temperature	AT	No	Displayed Air Temperature
Efficiency	EF	No	Displayed Efficiency
Carbon Monoxide	CO	No	Displayed Carbon Monoxide
Carbon Dioxide	CD	No	Displayed Carbon Dioxide
Instrument Status	SA	No	Instrument Status

## 9 OPERATION

Before attempting any serial communication, first ensure that the ZMT Analyzers connected to the computer terminal or host computer by serial link are functioning correctly as individual instruments. This is achieved by connecting all analog inputs, applying the input signals and checking that the digital display reads appropriately.

Ensure that the serial data connections to ZMT Analyzers have been made correctly with respect to the computer terminal, or host computer, interface. If the above check appears satisfactory, test the serial communication by sending an appropriate message from the computer terminal or host computer to a transmitter and observe if it replies; thus establishing communication. If communication is not established, check that the computer terminal, or host computer, interface is correctly set up and that the plug-in links within each transmitter are positioned correctly – see Section 5.

Check that the parameters programmed in the instrument's **Serial Data Communication Page** are compatible with those of the computer terminal or host computer – see Section 7.

If communication is still not possible or is erratic, check that the computer terminal, or host computer, interface has pull-up and pull-down resistors connected as shown in Figs. 9.1

**Note.** If no reply is received from the instrument within 160ms, retransmit the command. If after five command re-entries, a satisfactory reply has not been received, the communication link has been broken and must be rechecked.

## 10 SPECIFICATION

As detailed in the Operating Instructions (IM/ZMT), with the following additions:

EIA Communication Standards	RS422, RS485 4-wire mode	
Parity	None	} Programmable
	Odd	
	Even	
Block check character	Programmable on or off	
Transmission line length	1200m max.	
Transmission speeds	1200 baud	} Programmable
	2400 baud	
	4800 baud	
	9600 baud	

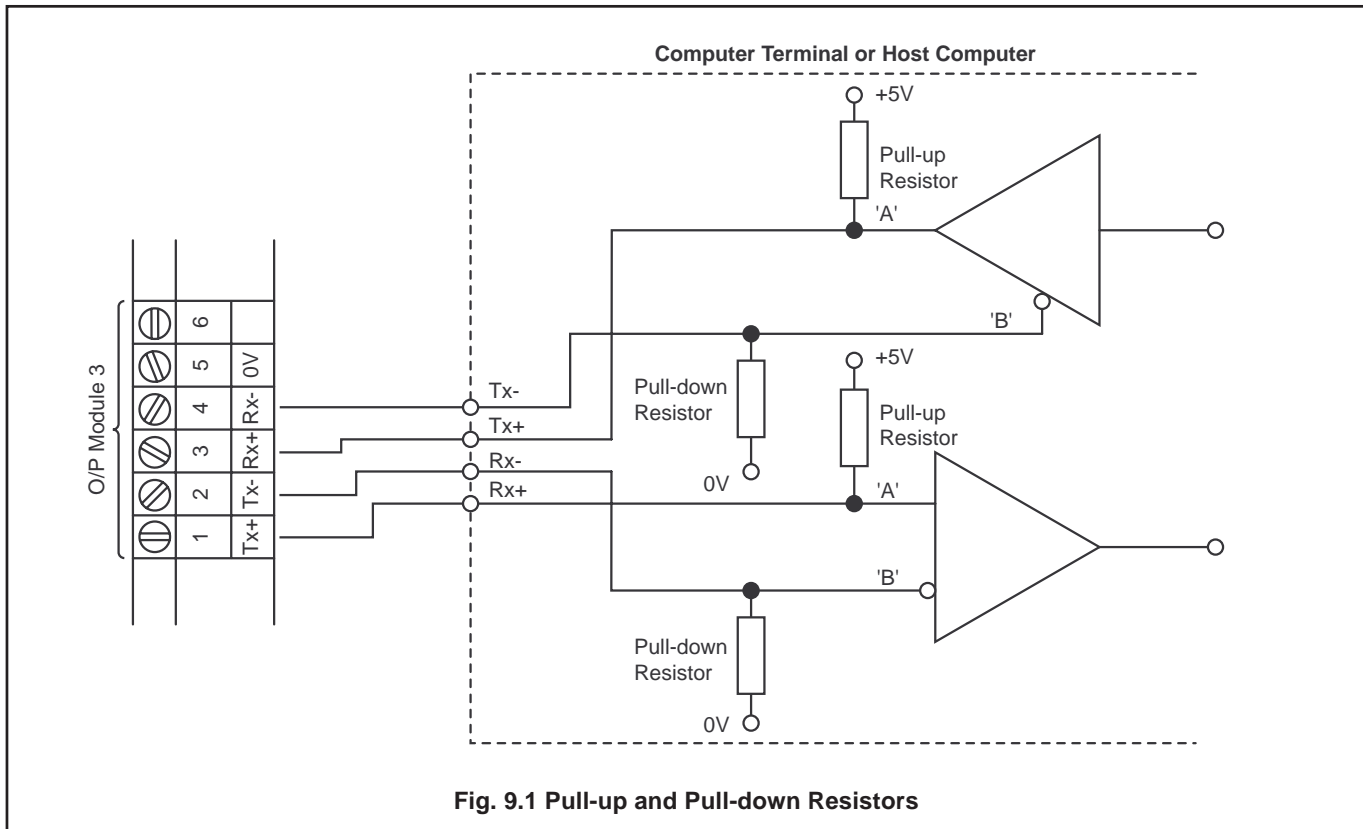

# APPENDICES

## A1 The American Standard Code for Information Interchange (ASCII)

Character	Significance	Decimal	Hex.	Binary
NUL	Null, Operation	0	00	0000000
SOH	Start of Heading	1	01	0000001
STX	Start of Text	2	02	0000010
ETX	End of Text	3	03	0000011
EOT	End of Transmission	4	04	0000100
ENQ	Enquiry	5	05	0000101
ACK	Acknowledgement	6	06	0000110
BEL	Bell	7	07	0000111
BS	Backspace	8	08	0001000
HT	Horizontal Tabulation	9	09	0001001
LF	Line Feed	10	0A	0001010
VT	Vertical Tabulation	11	0B	0001011
FF	Form Feed	12	0C	0001100
CR	Carriage Return	13	0D	0001101
SO	Shift Out	14	0E	0001110
SI	Shift In	15	0F	0001111
DLE	Data Link Escape	16	10	0010000
DC1	Device Control 1	17	11	0010001
DC2	Device Control 2	18	12	0010010
DC3	Device Control 3	19	13	0010011
DC4	Device Control 4	20	14	0010100
NAK	Negative Acknowledge	21	15	0010101
SYN	Synchronous Idle	22	16	0010110
ETB	End of Transmission Block	23	17	0010111
CAN	Cancel	24	18	0011000
EM	End of Medium	25	19	0011001
SUB	Substitute Character	26	1A	0011010
ESC	Escape	27	1B	0011011
FS	File Separator	28	1C	0011100
GS	Group Separator	29	1D	0011101
RS	Record Separator	30	1E	0011110
US	Unit Separator	31	1F	0011111
SP	Space	32	20	0100000
!	.....	33	21	0100001
"	.....	34	22	0100010
#	Number detection	35	23	0100011
\$	Other currency symbol	36	24	0100100
%	.....	37	25	0100101
&	.....	38	26	0100110
'	.....	39	27	0100111
(	.....	40	28	0101000
)	.....	41	29	0101001
*	.....	42	2A	0101010
+	.....	43	2B	0101011
,	.....	44	2C	0101100
-	.....	45	2D	0101101
.	.....	46	2E	0101110
/	.....	47	2F	0101111
0	.....	48	30	0110000
1	.....	49	31	0110001
2	.....	50	32	0110010
3	.....	51	33	0110011
4	.....	52	34	0110100
5	.....	53	35	0110101
6	.....	54	36	0110110
7	.....	55	37	0110111
8	.....	56	38	0111000
9	.....	57	39	0111001
:	.....	58	3A	0111010
;	.....	59	3B	0111011
<	.....	60	3C	0111100
=	.....	61	3D	0111101
>	.....	62	3E	0111110
?	.....	63	3F	0111111

# ...APPENDICES

Character	Significance	Decimal	Hex.	Binary
@	.....	64	40	1000000
A	.....	65	41	1000001
B	.....	66	42	1000010
C	.....	67	43	1000011
D	.....	68	44	1000100
E	.....	69	45	1000101
F	.....	70	46	1000110
G	.....	71	47	1000111
H	.....	72	48	1001000
I	.....	73	49	1001001
J	.....	74	4A	1001010
K	.....	75	4B	1001011
L	.....	76	4C	1001100
M	.....	77	4D	1001101
N	.....	78	4E	1001110
O	.....	79	4F	1001111
P	.....	80	50	1010000
Q	.....	81	51	1010001
R	.....	82	52	1010010
S	.....	83	53	1010011
T	.....	84	54	1010100
U	.....	85	55	1010101
V	.....	86	56	1010110
W	.....	87	57	1010111
X	.....	88	58	1011000
Y	.....	89	59	1011001
Z	.....	90	5A	1011010
[	.....	91	5B	1011011
\	.....	92	5C	1011100
]	.....	93	5D	1011101
^	.....	94	5E	1011110
--	.....	95	5F	1011111
`	.....	96	60	1100000
a	.....	97	61	1100001
b	.....	98	62	1100010
c	.....	99	63	1100011
d	.....	100	64	1100100
e	.....	101	65	1100101
f	.....	102	66	1100110
g	.....	103	67	1100111
h	.....	104	68	1101000
i	.....	105	69	1101001
j	.....	106	6A	1101010
k	.....	107	6B	1101011
l	.....	108	6C	1101100
m	.....	109	6D	1101101
n	.....	110	6E	1101110
o	.....	111	6F	1101111
p	.....	112	70	1110000
q	.....	113	71	1110001
r	.....	114	72	1110010
s	.....	115	73	1110011
t	.....	116	74	1110100
u	.....	117	75	1110101
v	.....	118	76	1110110
w	.....	119	77	1110111
x	.....	120	78	1111000
y	.....	121	79	1111001
z	.....	122	7A	1111010
{	.....	123	7B	1111011
	.....	124	7C	1111100
}	.....	125	7D	1111101
~	.....	126	7E	1111110
DEL	Delete	127	7F	1111111

## A2 Non-volatile Memory Limitations

**Note.** A non-volatile memory is used to store any parameter changes made via the serial link to ensure that the information is retained during mains interruption or power-down. The memory used is rated at  $10^4$  write cycles per register and each register is assigned a particular parameter, e.g. Alarm set point value. If the number of write cycles to any particular register exceeds this value, the register's contents may not be retained.

## A3 Block Check Characters

The block check character (BCC) transmitted is determined by the seven least significant bits in the binary arithmetic sum of a complete message (excluding parity bits). All characters transmitted before the BCC must be included in the arithmetic sum. Refer to Appendix A1 for ASCII characters.

### A3.1 BCC Example

Message – STXR01A1ETX

Find the ASCII decimal equivalent of each character in the message, calculate the decimal arithmetic sum and hence obtain the binary arithmetic sum.

STX	=	2	Arithmetic sum = 298 decimal 100101010 binary
R	=	82	
0	=	48	
1	=	49	
A	=	65	
1	=	49	
ETX	=	3	

Only the seven least significant bits (LSB) of the binary arithmetic sum are required to determine the BCC:

MSB                      LSB  
 10 0101010  
 └──────────┘  
 '★' is the BCC transmitted –  
 see Appendix A1

---

## NOTES

---

# PRODUCTS & CUSTOMER SUPPORT

## Products

### Automation Systems

- *for the following industries:*
  - Chemical & Pharmaceutical
  - Food & Beverage
  - Manufacturing
  - Metals and Minerals
  - Oil, Gas & Petrochemical
  - Pulp and Paper

### Drives and Motors

- *AC and DC Drives, AC and DC Machines, AC motors to 1kV*
- *Drive systems*
- *Force Measurement*
- *Servo Drives*

### Controllers & Recorders

- *Single and Multi-loop Controllers*
- *Circular Chart, Strip Chart and Paperless Recorders*
- *Paperless Recorders*
- *Process Indicators*

### Flexible Automation

- *Industrial Robots and Robot Systems*

### Flow Measurement

- *Electromagnetic Flowmeters*
- *Mass Flow Meters*
- *Turbine Flowmeters*
- *Flow Elements*

### Marine Systems & Turbochargers

- *Electrical Systems*
- *Marine Equipment*
- *Offshore Retrofit and Refurbishment*

### Process Analytics

- *Process Gas Analysis*
- *Systems Integration*

### Transmitters

- *Pressure*
- *Temperature*
- *Level*
- *Interface Modules*

### Valves, Actuators and Positioners

- *Control Valves*
- *Actuators*
- *Positioners*

### Water, Gas & Industrial Analytics Instrumentation

- *pH, conductivity, and dissolved oxygen transmitters and sensors*
- *ammonia, nitrate, phosphate, silica, sodium, chloride, fluoride, dissolved oxygen and hydrazine analyzers.*
- *Zirconia oxygen analyzers, katharometers, hydrogen purity and purge-gas monitors, thermal conductivity.*

## Customer Support

We provide a comprehensive after sales service via a Worldwide Service Organization. Contact one of the following offices for details on your nearest Service and Repair Centre.

### United Kingdom

ABB Limited  
Tel: +44 (0)1453 826661  
Fax: +44 (0)1453 829671

### United States of America

ABB Inc.  
Tel: +1 775 850 4800  
Fax: +1 775 850 4808

#### Client Warranty

Prior to installation, the equipment referred to in this manual must be stored in a clean, dry environment, in accordance with the Company's published specification.

Periodic checks must be made on the equipment's condition. In the event of a failure under warranty, the following documentation must be provided as substantiation:

1. A listing evidencing process operation and alarm logs at time of failure.
2. Copies of all storage, installation, operating and maintenance records relating to the alleged faulty unit.

---

**ABB** has Sales & Customer Support  
expertise in over 100 countries worldwide

[www.abb.com](http://www.abb.com)

The Company's policy is one of continuous product  
improvement and the right is reserved to modify the  
information contained herein without notice.

Printed in UK (09.05)

© ABB 2005



**ABB Limited**

Oldends Lane, Stonehouse  
Gloucestershire,  
GL10 3TA  
UK

Tel: +44 (0)1453 826661

Fax: +44 (0)1453 829671

**ABB Inc.**

Analytical Instruments  
9716 S. Virginia St., Ste. E  
Reno, Nevada 89521  
USA

Tel: +1 775 850 4800

Fax: +1 775 850 4808