

- **Ideal for small gas/oil fired boilers**
- **Cost-effective solution**
  - for OEM outlets with a quick return on end-user investment
- **Continuous on-line measurement**
  - at less than the price of a spot check portable instrument
- **Provides EN14001 performance data**
  - at an affordable price
- **NEMA 4X / IP66 Protection**
  - for the probe
- **Linear or Logarithmic ranges**
  - 0 to 5% up to 0 to 25% linear
  - 2 decades logarithmic from 0.01 to 25%
- **Comprehensive diagnostics and built-in software protection**
  - ensures security and confidence in operation



**Economic, efficient and  
environmentally friendly  
combustion control**

## Introduction

The AZ100 Zirconia Oxygen Analyzer is a versatile system designed primarily for the OEM boiler and burner controls market.

The system is a low-temperature type designed to work in process temperatures up to 600°C (1112°F) and with a maximum duct surface temperature of 400°C (752°F).

The analyzer provides oxygen computation, with readout and retransmission, based on the probe mV output signal. The output signal (E mV) is Nernstian in form and follows the equation:

$$E \text{ (mv)} = 0.0496T(\log_{10} P_0 / P_1) \pm \text{CmV}$$

Where: T = Absolute temperature  
 $P_0$  = Reference O<sub>2</sub> partial pressure  
 $P_1$  = Sample O<sub>2</sub> partial pressure  
 C = Cell constant (mV zero offset)  
 0.0496 = Faraday's gas constant

## Probe Design

The probe uses the proven and innovative ABB electrode and cell design technology which has been so reliable in other ABB zirconia probe designs.

The flexible probe design gives a range of intake tube lengths to suit all applications and an optional filter/flame arrester making it safe for use where groups IIB and IIC gases may occur in the process being measured. The probe has options of male thread NPT or BSPT mountings. As with all previous ABB designs of low temperature probes, the AZ100 probe is site-serviceable.

As the sensor housing is located on the outside of the duct wall, diffusion of reference air into the sensor housing is sufficient; thus eliminating the need for an air pump or instrument air supply.

The reference air diffuses into the housing through a porous membrane which restricts entry to air only and maintains the IP66 (NEMA 4X) protection.



## Transmitter Design



The transmitter has, as standard, high/low alarm relays and a single linear or logarithmic isolated retransmission. Display features include %O<sub>2</sub>, cell temperature, heater control output, cell mV, alarm set points, calibration sequence diagnostics and output settings.

At system startup the transmitter controls the level of power to the mains-powered heater within the probe to eliminate the risk of thermal shock to the sensor.

Based on the proven 4600 Series of transmitters, the AZ100 transmitters are environmentally protected to NEMA 4X (IP65)\*, and meet the requirements EN61326 for industrial locations.

The AZ100 transmitters have a green, backlit LCD display and four tactile membrane switches for operation and programming. The measured value display is a 5-digit, 7-segment LCD, while the information display is a 16-character, single line, dot-matrix.

The information display can be user-programmed for display in English, French, German or Spanish.

The  Switch enables movement from the 'Operating Page' to the oxygen calibration sequence. Use of the appropriate security code allows further access to the pages for 'Setup Outputs' and 'Electrical Calibration'. The  switch is used to select the various programming pages, while the  and  switches change the programmable values.

\* Refer to **Specification – Transmitter** for full details.

## Specification – Transmitter

### Display

#### Measured value

5-digit x 7-segment, backlit LCD

#### Information

16-character, single-line, dot-matrix, backlit LCD

#### Parameters

%O<sub>2</sub> (0 to 25%)

Cell temperature

Cell mV

Two alarm set points

Alarm 2 can be configured as a general alarm for any of the following:

- THC open circuit + check THC open circuit, short circuit or reversed
- Cell warming up
- Calibration failed
- Cell stability check
- Power failure

---

### Accuracies

#### Oxygen concentration (display and retransmission)

≤3% of reading or ±0.1% O<sub>2</sub> (whichever is the greater)

#### Display resolution

±1 digit

---

### Environmental Data

#### Operating temperature limits

-5 to 55° C (23 to 131° F) all functions

-20° to 70° C (-4 to 158° F) retransmission

#### Storage temperature

-25 to 75° C (-13 to 131° F)

#### Operating humidity limits

Up to 95% RH non-condensing

---

### Power Supply

#### Voltage requirements

100 to 130V, 200 to 260V 50/60 Hz

Nom. 115/230V AC 50/60Hz

#### Power consumption (total system)

113VA at start up (sensor)

6VA at start up (transmitter)

47VA operational

#### Insulation

Mains to earth (line to ground) 2kV RMS

### Outputs and Set Points

#### No. of relays

Two

#### Relay Contacts

Single pole changeover

Rating 3A 250V AC

3A 250V DC

Loading (non-inductive) 750VA 30W

Loading ( inductive) 75VA 3W

#### Insulation

2kV RMS contacts to earth (ground)

#### No. of alarm set points

Two

#### Set point adjustment

Programmable

#### Set point hysteresis

±1% of set point (fixed)

#### Local set point annunciation

Red LED

#### Retransmission

One fully isolated retransmission output

Linear output

Range 0 to 25% O<sub>2</sub> programmable

Minimum span 5%

Logarithmic output

Range 0.1 to 25% O<sub>2</sub> programmable

Minimum span any 2 decades in range

#### Output Current

0 to 10mA, 0 to 20mA or 4 to 20mA user-programmable

#### Resolution

0.1% at 10mA, 0.05% at 20mA

#### Max. load resistance

750Ω ( 20 mA max.)

#### Output loop test

Output loop test at 0%, 25%, 50%, 75% and 100% of output span

## ...Specification – Transmitter

### Mechanical Data

#### Mounting Options

Wall-mount  
Post-mount  
Panel-mount

#### Protection to NEMA 4X (IP65)

Wall/post mount transmitter  
Panel-mount transmitter (front only)

#### Overall Dimensions

Wall-mount transmitter  
160mm wide x 214mm high x 68mm deep  
(6.3 in. wide x 8.43 in. high x 2.68 in. deep)

Panel-mount transmitter  
96mm x 96mm x 191mm deep  
(3.78 in. x 3.78 in. x 7.52 in. deep)

#### Weight

Wall-mount transmitter	2.0kg (4.4 lb)
Panel-mount transmitter	1.5kg (3.3 lb)
Post-mount kit	1.5kg (3.3 lb)

## System Accuracy

#### Display

≤2% of reading or ±0.1% O<sub>2</sub> (whichever is the greater),  
for 30°C ambient temperature change

#### Retransmission

≤3% of reading or ±0.1% O<sub>2</sub> (whichever is the greater),  
for 30°C ambient temperature change

#### Error due to power supply variation

<0.1% O<sub>2</sub> for ±10% variation from normal supply voltage

#### Error due to flue wall temperature change

0.017% of reading/°C (0.008% of reading/°F)

\* for 2 point calibration against certified test gases

## Specification – Probe

### Environmental Data

#### Process gas temperature

–20 to 600°C (–4 to 1112°F)

#### Maximum duct surface temperature

–400°C (–752°F)

#### Ambient air temperature

–20 to 70°C (–4 to 158°F)

#### Environmental protection

NEMA 4X/IP66 ( hose down)

---

### Electrical Data

#### Signal cable

6-way, multicore, screened cable with copper conductors  
available in standard lengths of 25, 50 or 100m  
(81.25, 162.5 or 325 ft.)

#### Thermocouple

NiCr/NiAl Pt.4 BS4937 Type K

---

### Mechanical Data

#### Insertion lengths

200, 350, 500 or 650mm (7.9, 13.8, 19.7 or 25.6 in.)

#### Response time

3s  
Time to t<sub>90</sub> 35s (typical)

#### Mountings

2 in. NPT, 2 in. BSPT or Adapter/ Standoff spool to suit  
the 0.4m ZFG2 mounting plate

#### Overall dimensions

See page 10

#### Weight

Probe complete with mounting flange and the following length  
intakes:

200mm (7.9 in.) – 4.8kg (10.6 lb)  
350mm (13.8 in.) – 5.1kg (11.2 lb)  
500mm (19.7 in.) – 5.4kg (11.9 lb)  
650mm ( 25.6 in.) – 5.7kg (12.5 lb)

#### Serviceability

Site-serviceable (replaceable sensor/oven assembly,  
filter/flame arrester and intake tubes)

### Electrical Connections

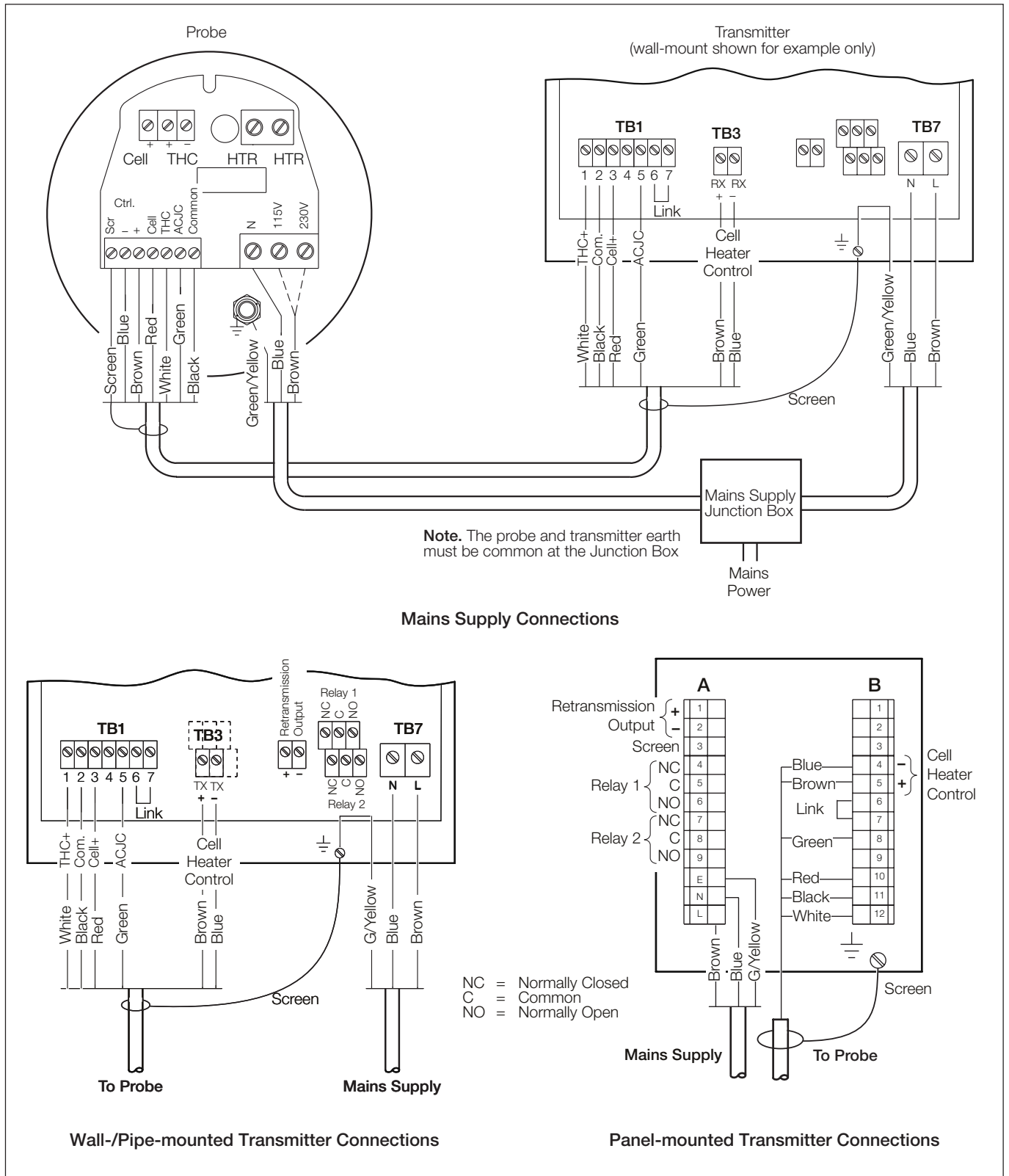

### Mains Supply Connections

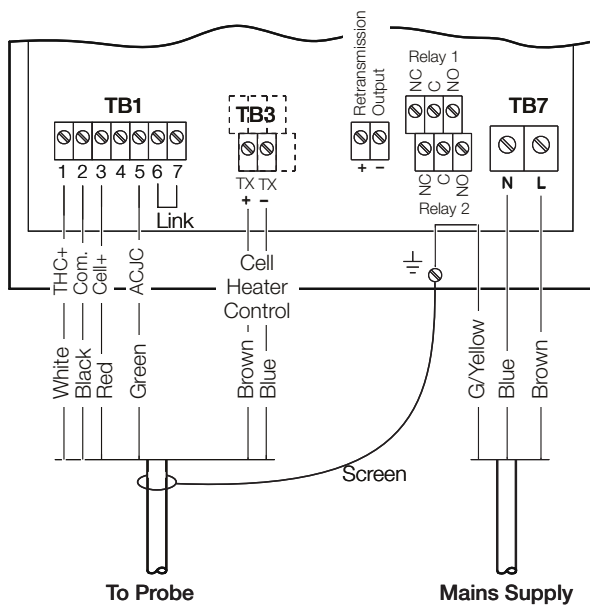

Wall-/Pipe-mounted Transmitter Connections

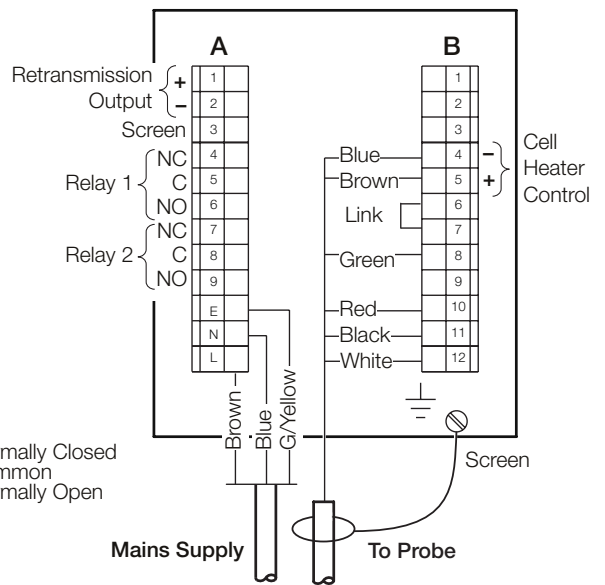

Panel-mounted Transmitter Connections

NC = Normally Closed  
C = Common  
NO = Normally Open

**Overall Dimensions**

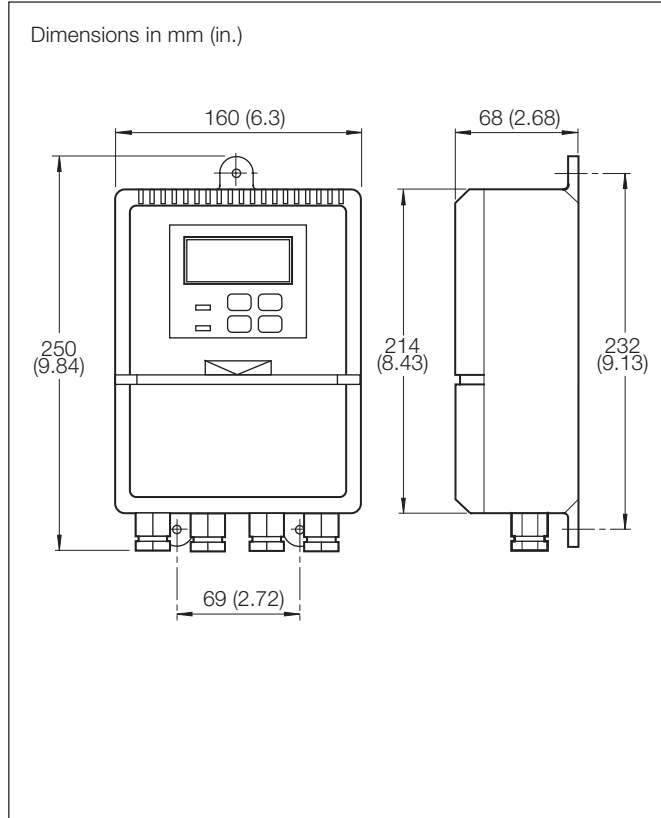

Wall-mount Transmitter

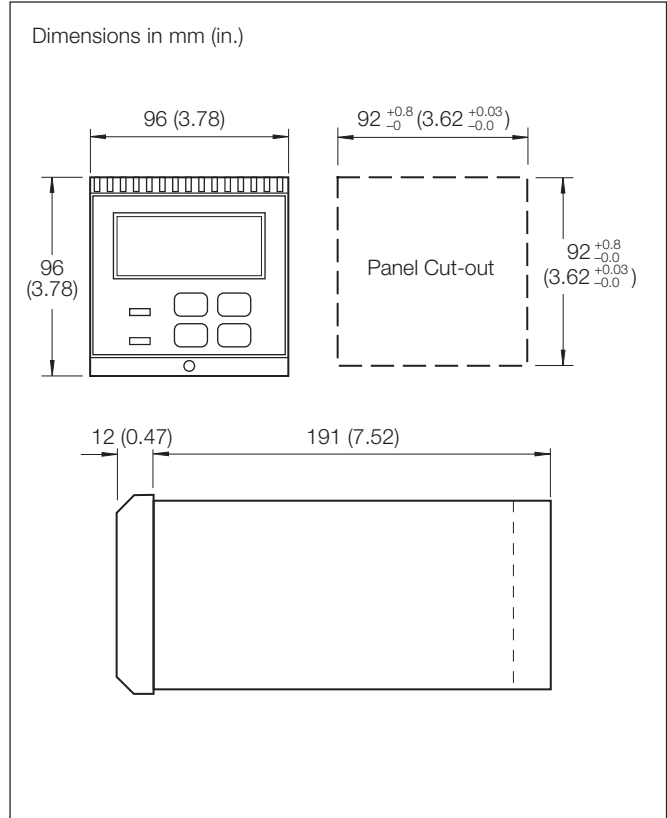

Panel-mount Transmitter

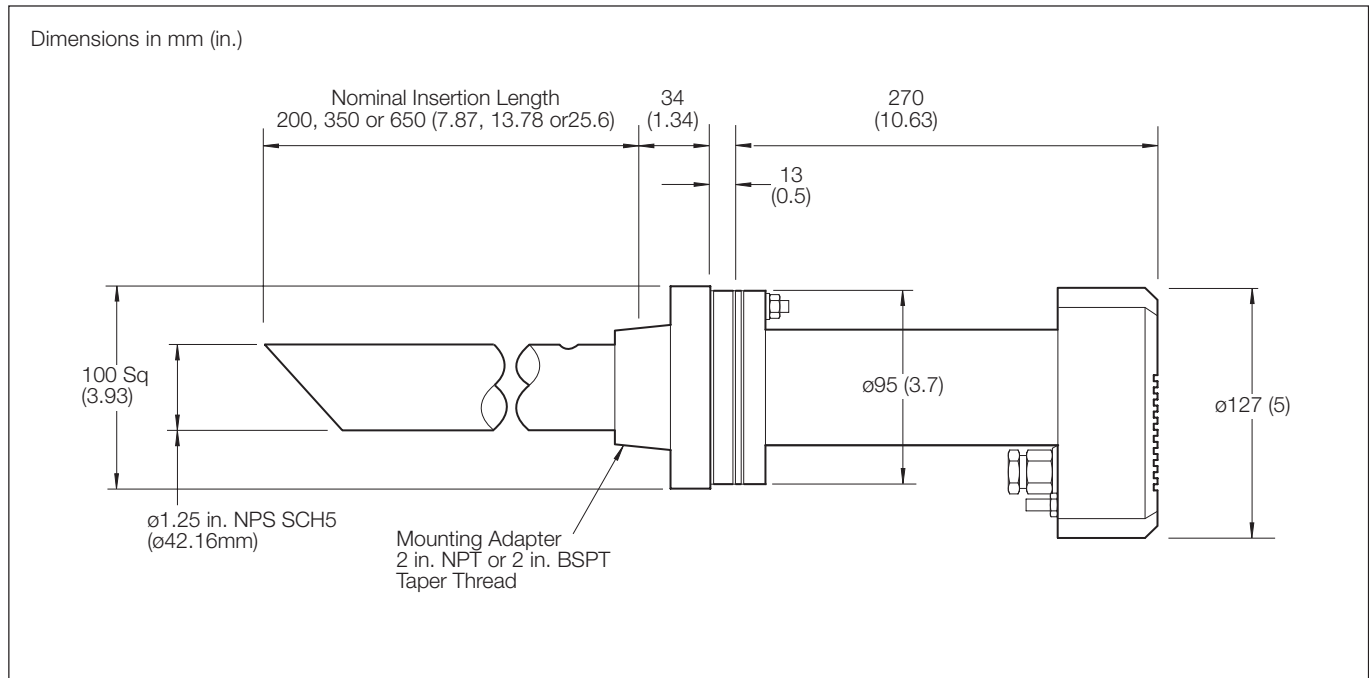

Probe

**Ordering Information**

AZ100 Series Zirconia Oxygen Analyzer for Small Boiler Applications	AZ1	X	X/	X	X	X	X	X	X
<b>Probe</b>									
Not required		0							
No purge with arrester		2							
<b>Sample Tube Length</b>									
200mm sample tube			1						
350mm sample tube			2						
500mm sample tube			3						
650mm sample tube			4						
<b>Probe Mount</b>									
Not required				0					
2 in. NPT				1					
2 in. BSP				2					
<b>Transmitter</b>									
Not required						0			
230V Wall-mount						1			
230V Post-mount						2			
230V Panel-mount						3			
115V Wall-mount						4			
115V Post-mount						5			
115V Panel-mount						6			
<b>Signal Cable</b>									
Not required							0		
10m							1		
25m							2		
50m							3		
100m (maximum)							4		
<b>Approvals</b>									
CE only								0	
<b>Language</b>									
English									1
German									2
French									3
Spanish									4
<b>Configuration</b>									
ABB (Standard)									0

**ABB** has Sales & Customer Support  
expertise in over 100 countries worldwide

[www.abb.com](http://www.abb.com)

The Company's policy is one of continuous product  
improvement and the right is reserved to modify the  
information contained herein without notice.

Printed in UK (09.08)

© ABB 2008



**ABB Limited**

Oldends Lane, Stonehouse  
Gloucestershire  
GL10 3TA  
UK  
Tel: +44 (0)1453 826661  
Fax: +44 (0)1453 829671

**ABB Inc.**

Analytical Instruments  
9716 S. Virginia St., Ste. E  
Reno, Nevada 89521  
USA  
Tel: +1 775 850 4800  
Fax: +1 775 850 4808