

Models 4620 and 4625
Conductivity Transmitters

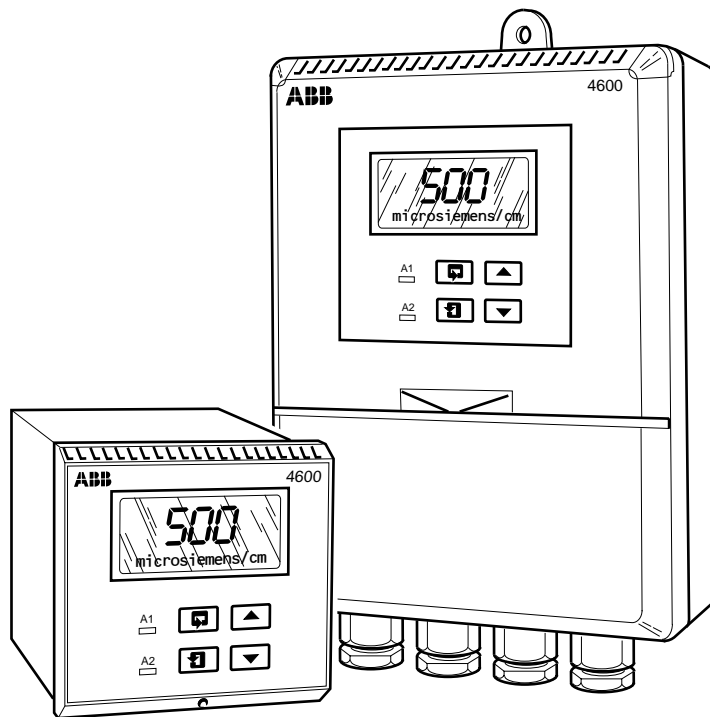

The Company

We are an established world force in the design and manufacture of instrumentation for industrial process control, flow measurement, gas and liquid analysis and environmental applications.

As a part of ABB, a world leader in process automation technology, we offer customers application expertise, service and support worldwide.

We are committed to teamwork, high quality manufacturing, advanced technology and unrivalled service and support.

The quality, accuracy and performance of the Company's products result from over 100 years experience, combined with a continuous program of innovative design and development to incorporate the latest technology.

The NAMAS Calibration Laboratory No. 0255 is just one of the ten flow calibration plants operated by the Company, and is indicative of our dedication to quality and accuracy.

BS EN ISO 9001



Cert. No. Q5907

EN 29001 (ISO 9001)



Lenno, Italy – Cert. No. 9/90A



Stonehouse, U.K.

Use of Instructions



Warning.

An instruction that draws attention to the risk of injury or death.



Note.

Clarification of an instruction or additional information.



Caution.

An instruction that draws attention to the risk of damage to the product, process or surroundings.



Information.

Further reference for more detailed information or technical details.

Although **Warning** hazards are related to personal injury, and **Caution** hazards are associated with equipment or property damage, it must be understood that operation of damaged equipment could, under certain operational conditions, result in degraded process system performance leading to personal injury or death. Therefore, comply fully with all **Warning** and **Caution** notices.

Information in this manual is intended only to assist our customers in the efficient operation of our equipment. Use of this manual for any other purpose is specifically prohibited and its contents are not to be reproduced in full or part without prior approval of the Marketing Communications Department.

Health and Safety

To ensure that our products are safe and without risk to health, the following points must be noted:

1. The relevant sections of these instructions must be read carefully before proceeding.
2. Warning labels on containers and packages must be observed.
3. Installation, operation, maintenance and servicing must only be carried out by suitably trained personnel and in accordance with the information given.
4. Normal safety precautions must be taken to avoid the possibility of an accident occurring when operating in conditions of high pressure and/or temperature.
5. Chemicals must be stored away from heat, protected from temperature extremes and powders kept dry. Normal safe handling procedures must be used.
6. When disposing of chemicals ensure that no two chemicals are mixed.

Safety advice concerning the use of the equipment described in this manual or any relevant hazard data sheets (where applicable) may be obtained from the Company address on the back cover, together with servicing and spares information.

CONTENTS

Section	Page	Section	Page
1 INTRODUCTION	2	6 OPERATION	16
2 PREPARATION	2	6.1 Instrument Start-up	16
2.1 Checking the Code Number	2	6.2 Operating Page	16
2.1.1 Wall-/Pipe-mounted Instruments	2	7 PROGRAMMING	17
2.1.2 Panel-mounted Instruments	2	7.1 Access to Secure Parameters	18
2.1.3 Conductivity Cells	3	7.2 Language Page	18
3 MECHANICAL INSTALLATION	4	7.3 Set Up Parameters Page	18
3.1 Siting Requirements	4	7.4 Set Up Alarms Page	21
3.1.1 Instruments	4	7.5 Set Up Retransmission Page	23
3.1.2 Conductivity Cells	4	7.6 Output Functions	26
3.2 Mounting	5	7.6.1 Bi-linear Output	26
3.2.1 Wall-/Pipe-mounted Instruments	5	7.6.2 2-decade Logarithmic Output	26
3.2.2 Panel-mounted Instruments	6	7.6.3 3-decade Logarithmic Output	27
3.3 Cleaning Conductivity Cells	7	7.6.4 2-decade Hyperbolic Output	27
3.3.1 Stainless Steel Screw-In and Withdrawable Conductivity Cells	7	7.6.5 ABB Semi-logarithmic Output	28
3.3.2 Epoxy Resin Conductivity Cells	7	8 CALIBRATION	29
3.4 Installing the Conductivity Cells	7	8.1 Equipment Required	29
3.4.1 Bulkhead Socket	7	8.2 Preparation	29
3.4.2 Screw-in Cells (Models 2077 and 2078)	7	8.3 Factory Settings Page	30
3.4.3 Dip-type Cell (Model 2025)	8	9 SIMPLE FAULT FINDING	32
3.4.4 Flow-line Cell (Model 2045)	8	9.1 Error Messages	32
3.4.5 Withdrawable Cell and Valve Assembly (Models 2085 and 2089)	8	9.2 No Response to Conductivity Changes	32
4 ELECTRICAL CONNECTIONS	9	9.3 Checking the Temperature Input	32
4.1 Access to Terminals	9	10 SPECIFICATION	33
4.1.1 Wall-/Pipe-mounted Instruments	9	APPENDICES	34
4.1.2 Panel-mounted Instruments	9	A1 Automatic Temperature Compensation	34
4.2 Connections, General	10	A1.1 Calculation of Temperature Coefficient	35
4.2.1 Relay Contact Protection and Interference Suppression	10	A2 Relationship Between Conductivity and Total Dissolved Solids (T.D.S.) Measurement	35
4.3 Wall-/Pipe-mounted Instrument Connections	11	A3 Insertion and Removal of Withdrawable Conductivity Cells	36
4.4 Panel-mounted Instrument Connections	12	A3.1 Insertion	36
4.5 Selecting the Mains Voltage	13	A3.2 Removal	36
4.5.1 Wall-/Pipe-mounted Instruments	13		
4.5.2 Panel-mounted Instruments	13		
4.6 Conductivity Cell and Bulkhead Socket Connections	14		
5 CONTROLS AND DISPLAYS	15		
5.1 Displays	15		
5.2 Control Familiarisation	15		

1 INTRODUCTION

The 4620 and 4625 conductivity transmitters and associated measuring cells have been designed for continuous monitoring and control of the conductivity of demineralised water, steam condensates, water distillates, raw water and de-ionised water. The transmitters can also indicate Total Dissolved Solids (T.D.S.) and Salinity in p.p.m calculated from the measured conductivity.

The 4620 model is a wall-mounted instrument and the 4625 model a panel-mounted, DIN sized instrument. Both instruments have a single programmable conductivity input channel and a single temperature input channel. When making temperature compensated measurements the sample temperature is sensed by a Pt100 resistance thermometer mounted in the measuring cell or, alternatively, using a separate temperature sensor.

Instrument operation and programming is via four tactile membrane keys located on the front panel. Programmed functions are protected from unauthorised alteration by a five-digit security code.

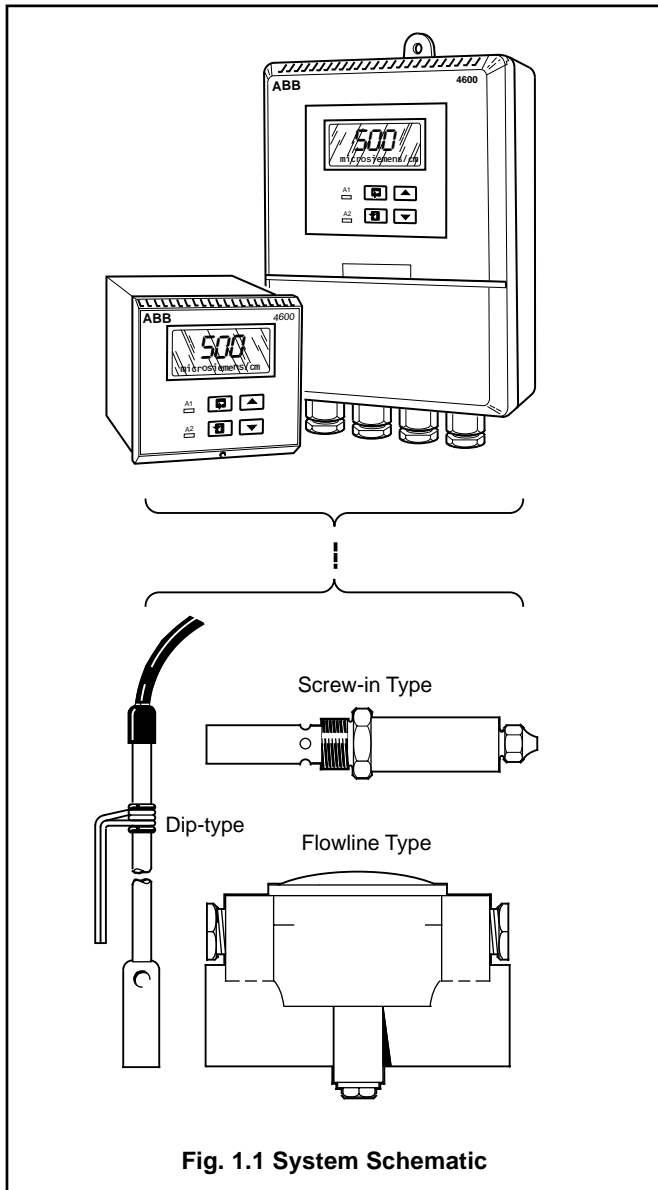

Fig. 1.1 System Schematic

2 PREPARATION

2.1 Checking the Code Number

2.1.1 Wall-/Pipe-mounted Instruments – Fig. 2.1

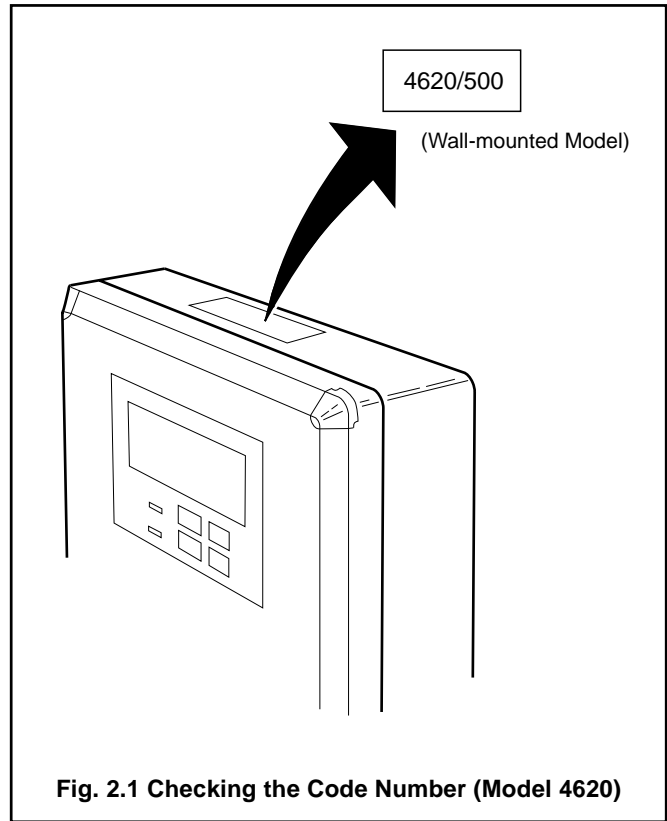

Fig. 2.1 Checking the Code Number (Model 4620)

2.1.2 Panel-mounted Instruments – Fig. 2.2

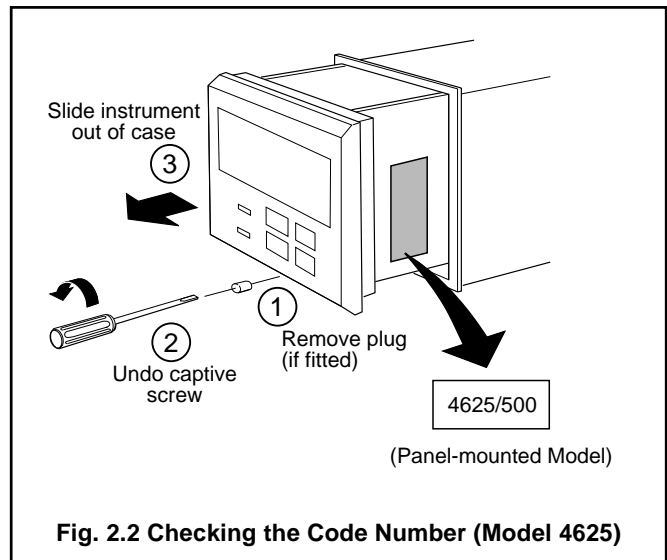
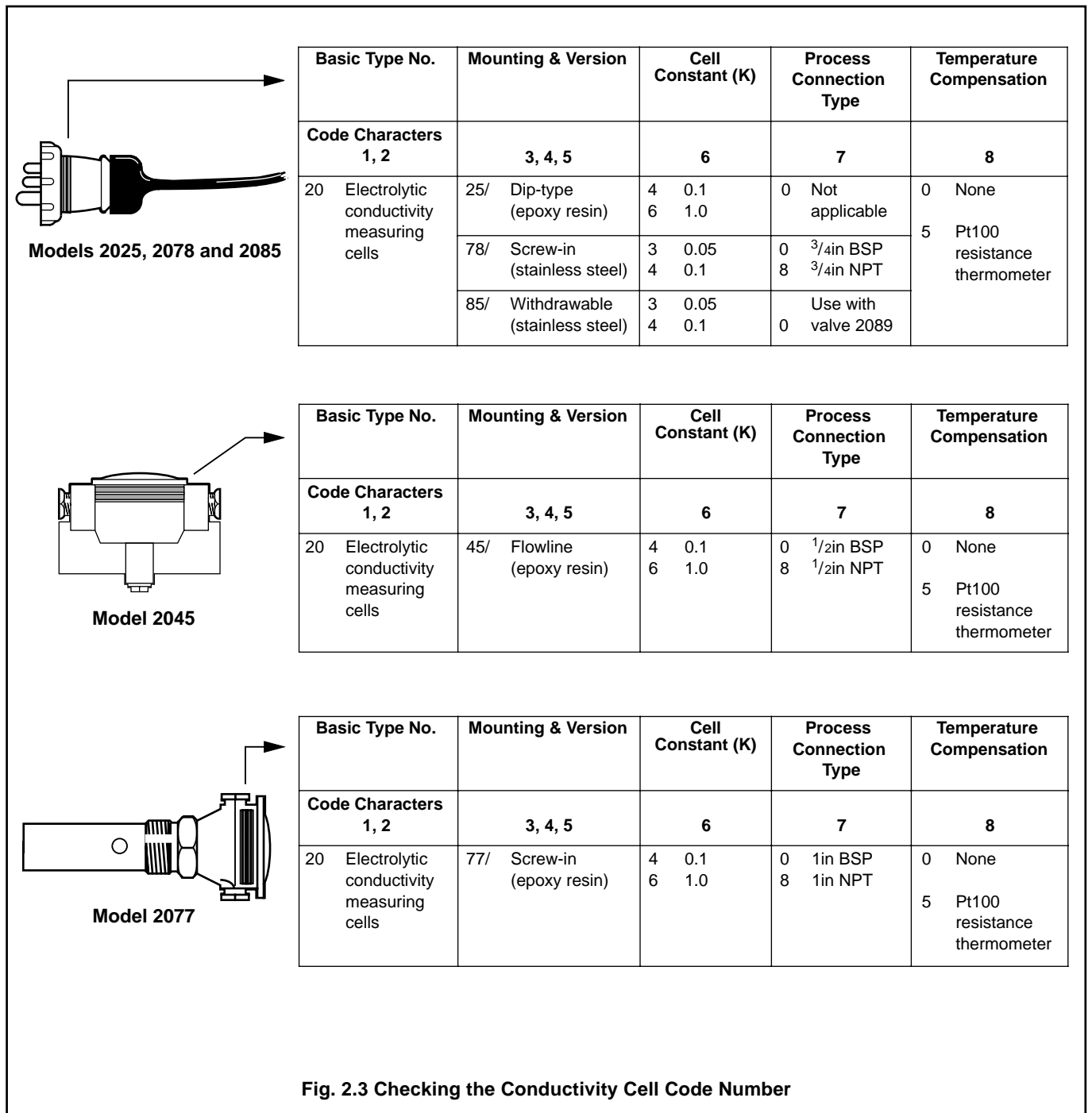

Fig. 2.2 Checking the Code Number (Model 4625)

2.1.3 Conductivity Cells – Fig. 2.3



3 MECHANICAL INSTALLATION

3.1 Siting Requirements

3.1.1 Instruments – Fig. 3.1



Caution.

- Mount in a location free from excessive vibration.
- Mount away from harmful vapours and/or dripping fluids.



Information. It is preferable to mount the instrument at eye level, allowing an unrestricted view of the front panel displays and controls.

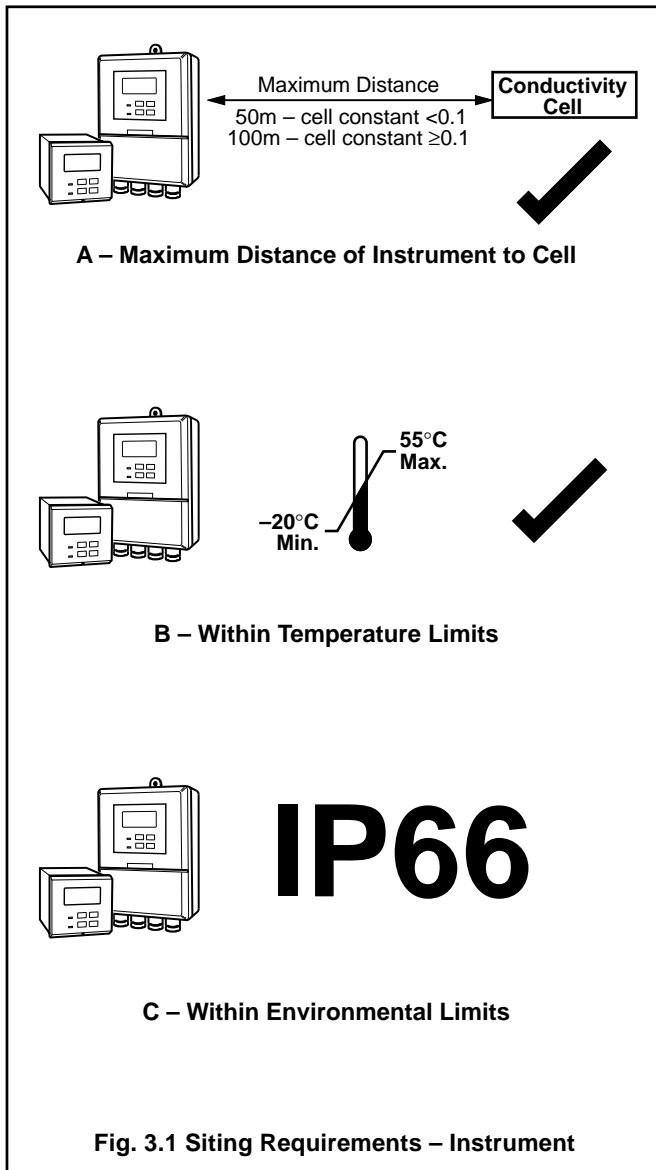

3.1.2 Conductivity Cells – Fig. 3.2



Caution. Ensure that the integral cable (where applicable) does not hang against hot or abrasive objects when the plug is connected to the bulkhead socket.



Note. Allow sufficient clearance for easy removal of cell for cleaning – see Section 3.4 for overall dimensions of cells.

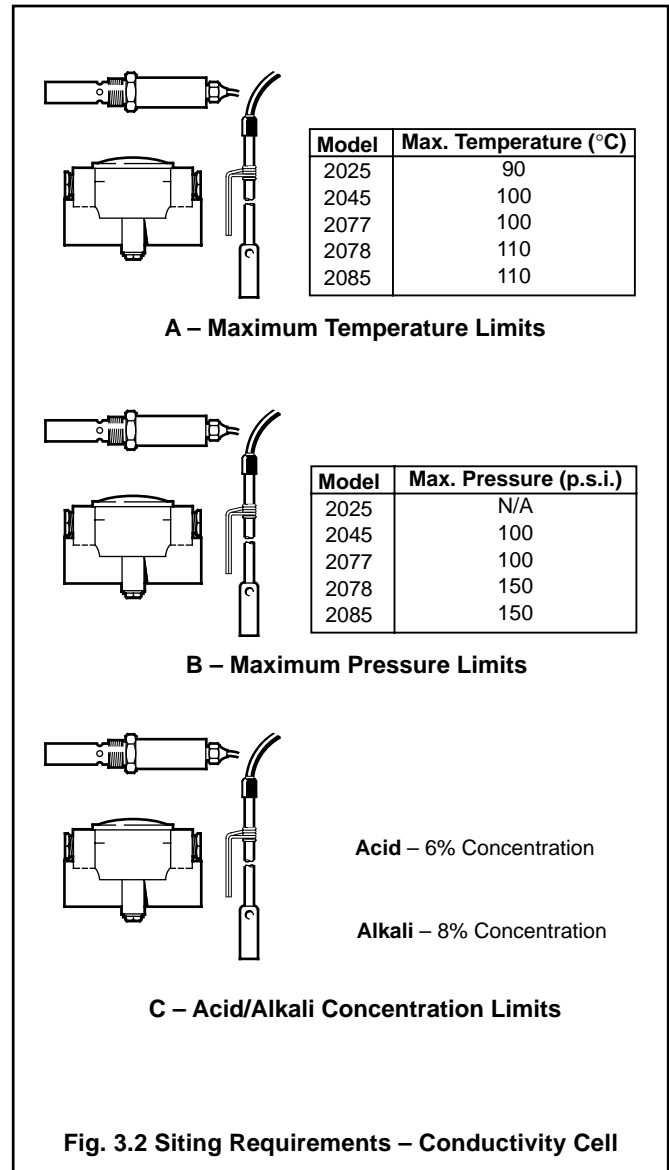

3.2 Mounting

3.2.1 Wall-/Pipe-mounted Instruments – Figs. 3.3 and 3.4

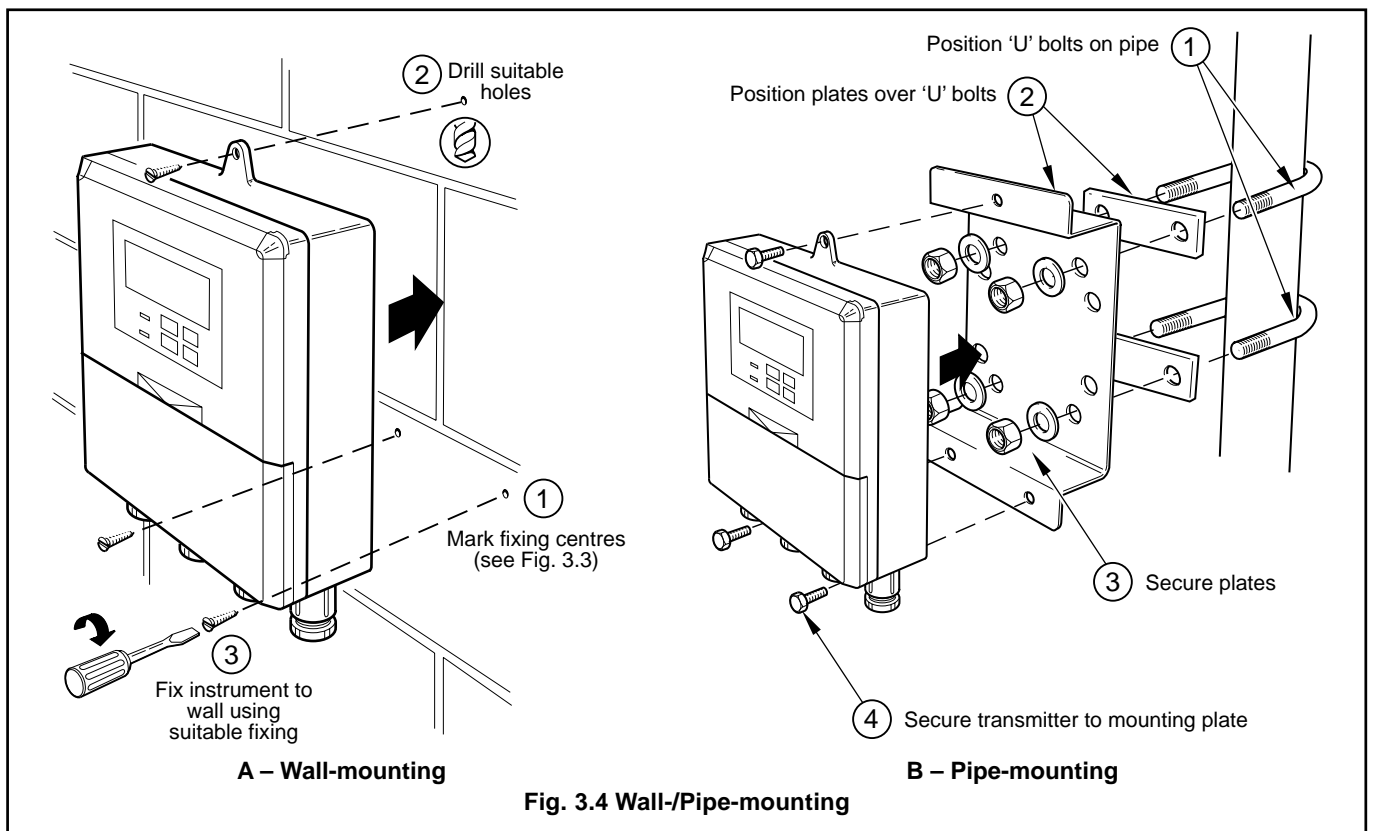
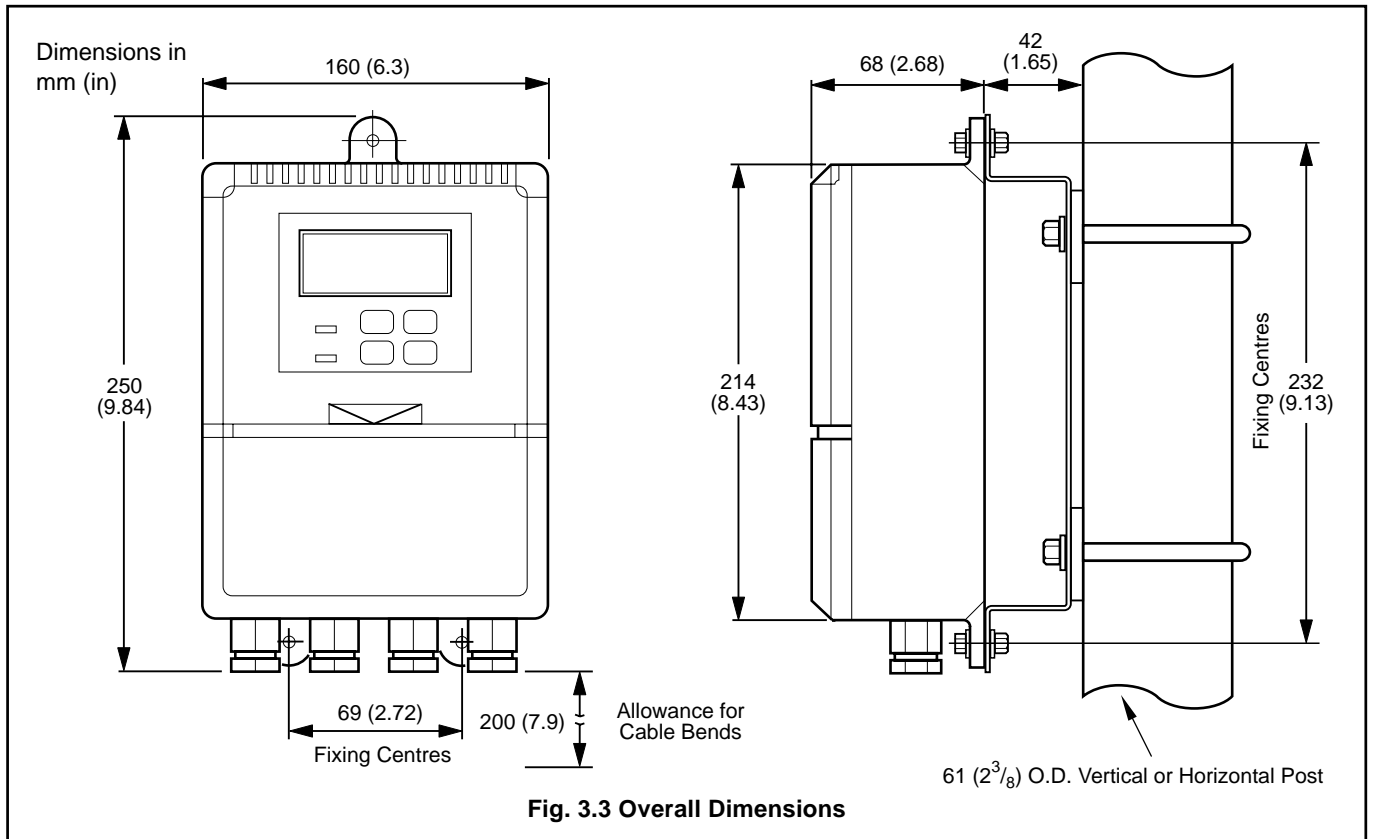

...3 MECHANICAL INSTALLATION

...3.2 Mounting

3.2.2 Panel-mounted Instruments – Figs. 3.5 and 3.6

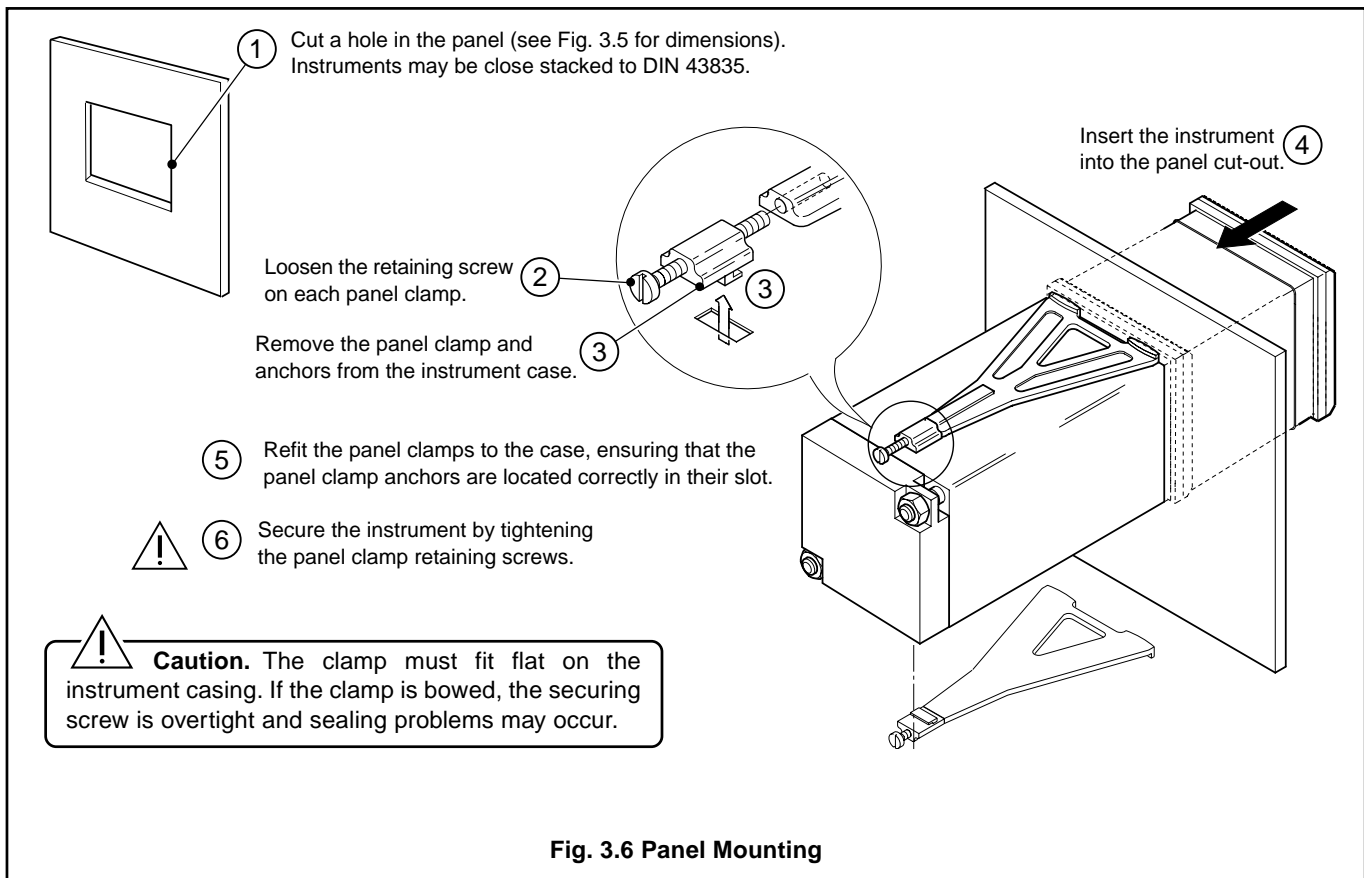
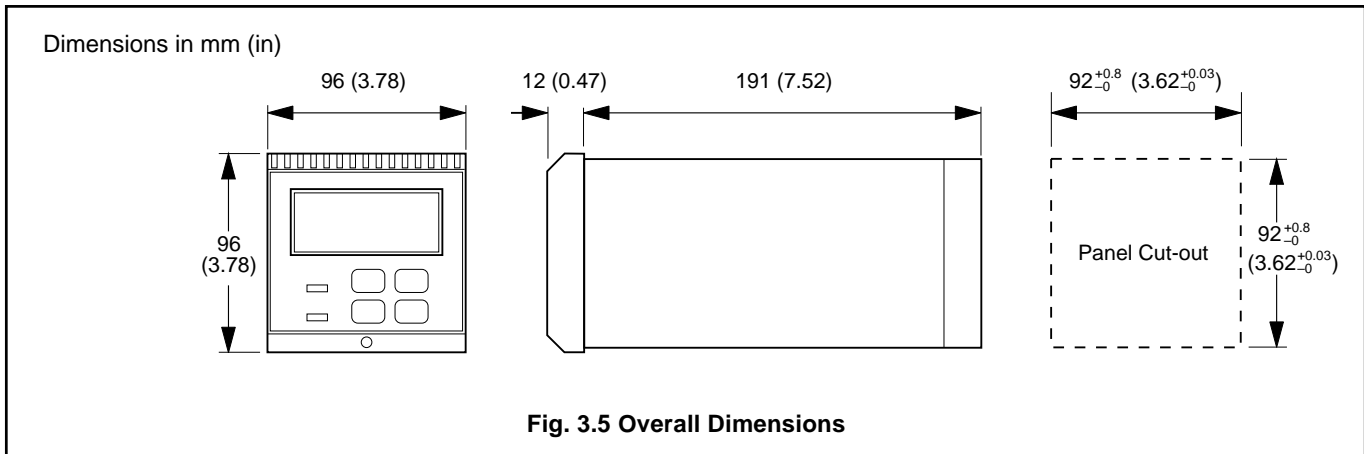

3.3 Cleaning Conductivity Cells

Before installing a conductivity cell, clean the electrodes as follows.

3.3.1 Stainless Steel Screw-In and Withdrawable Conductivity Cells

Unscrew the outer electrode and thoroughly clean it with a nylon-bristle brush (supplied) and a warm detergent solution. Clean the central electrode in a similar manner, taking care not to damage it. For more tenacious deposits a 2% hydrochloric acid solution may be used. Rinse thoroughly with distilled water after cleaning. The electrodes should have a dull, frosted appearance which must not be removed by polishing or abrasive cleaning. Refit the outer electrode.

3.3.2 Epoxy Resin Conductivity Cells

Thoroughly clean the electrode bore with a nylon-bristle brush (supplied) and a warm detergent solution. For more tenacious deposits a 2% hydrochloric acid solution may be used. After cleaning, thoroughly rinse the cell with distilled water and view the bore against a bright light to ensure that the interior surfaces are evenly wetted, i.e. free from grease deposits. Avoid wetting the electrical connection terminals.

3.4 Installing the Conductivity Cells

Caution. After cleaning and installing a conductivity cell, ensure it remains filled with liquid and is not allowed to dry out.

3.4.1 Bulkhead Socket – Fig. 3.7

Note. Used with cell types 2025, 2078, and 2085. Mount the socket at a convenient location close to the cell.

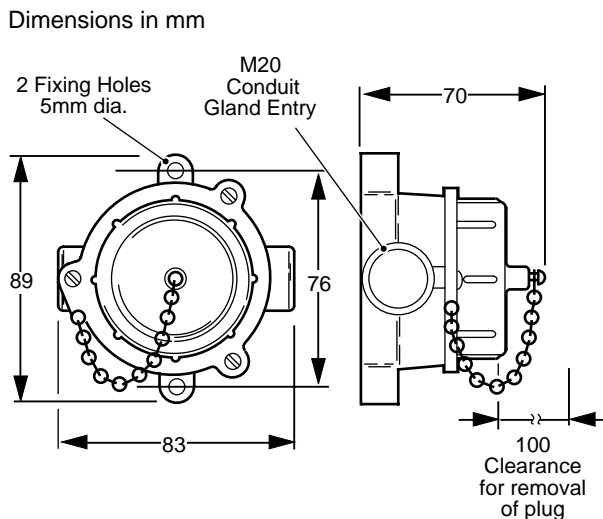
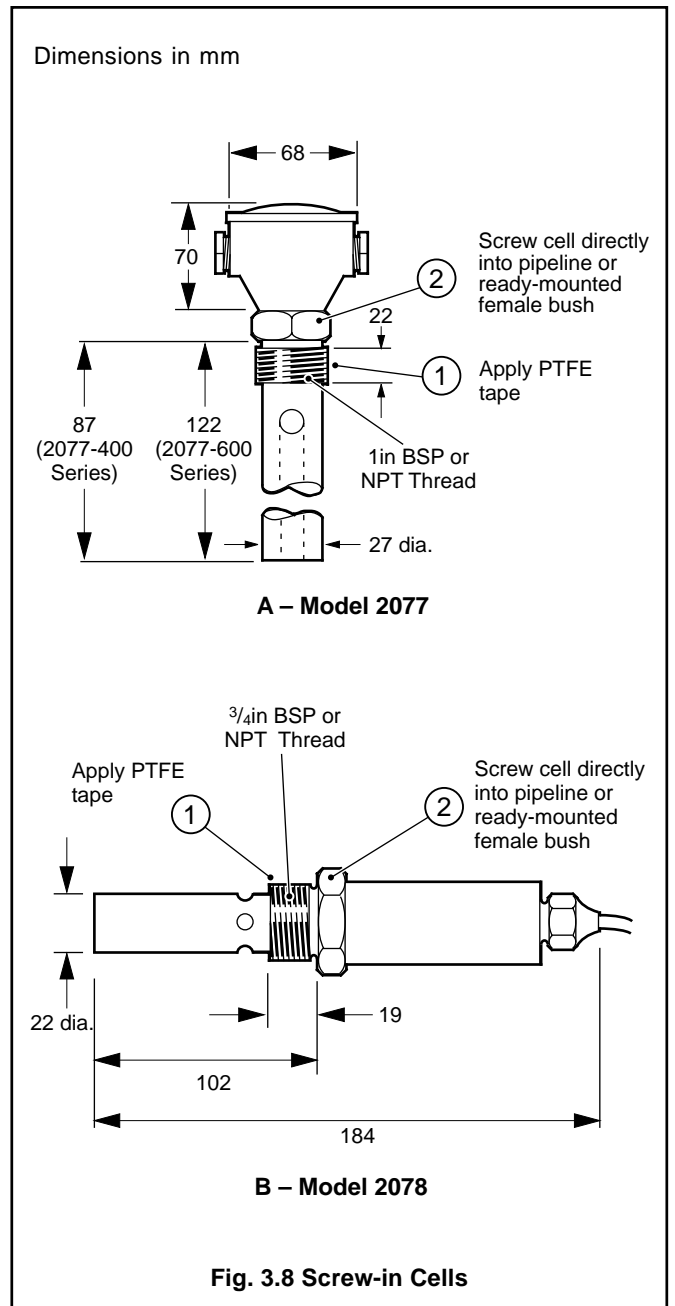

Fig. 3.7 Bulkhead Socket

3.4.2 Screw-in Cells (Models 2077 and 2078) – Fig. 3.8



4 ELECTRICAL CONNECTIONS



Warning. Before making any connections, ensure that the power supply, any high voltage-operated control circuits and high common mode voltages are switched off.

4.1 Access to Terminals

4.1.1 Wall-/Pipe-mounted Instruments – Fig. 4.1

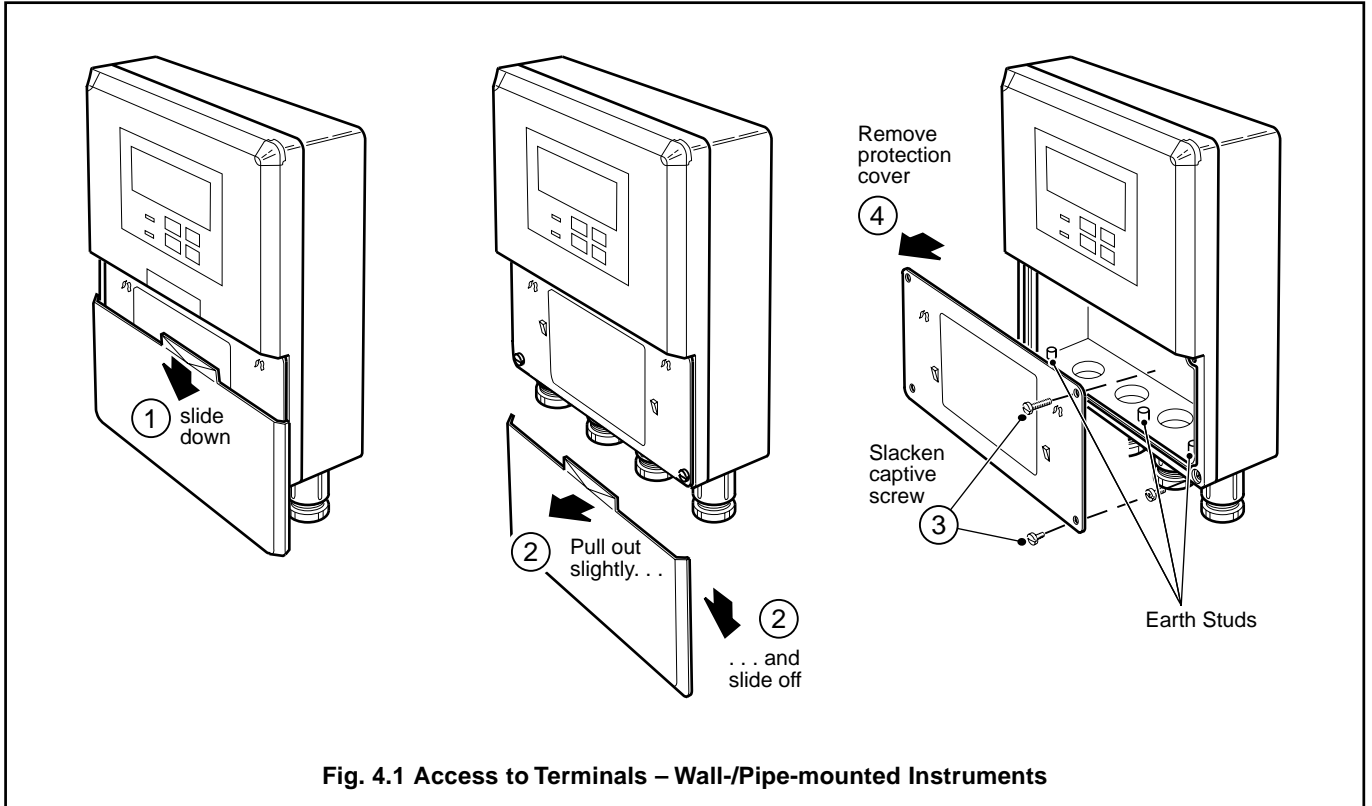

4.1.2 Panel-mounted Instruments – Fig. 4.2

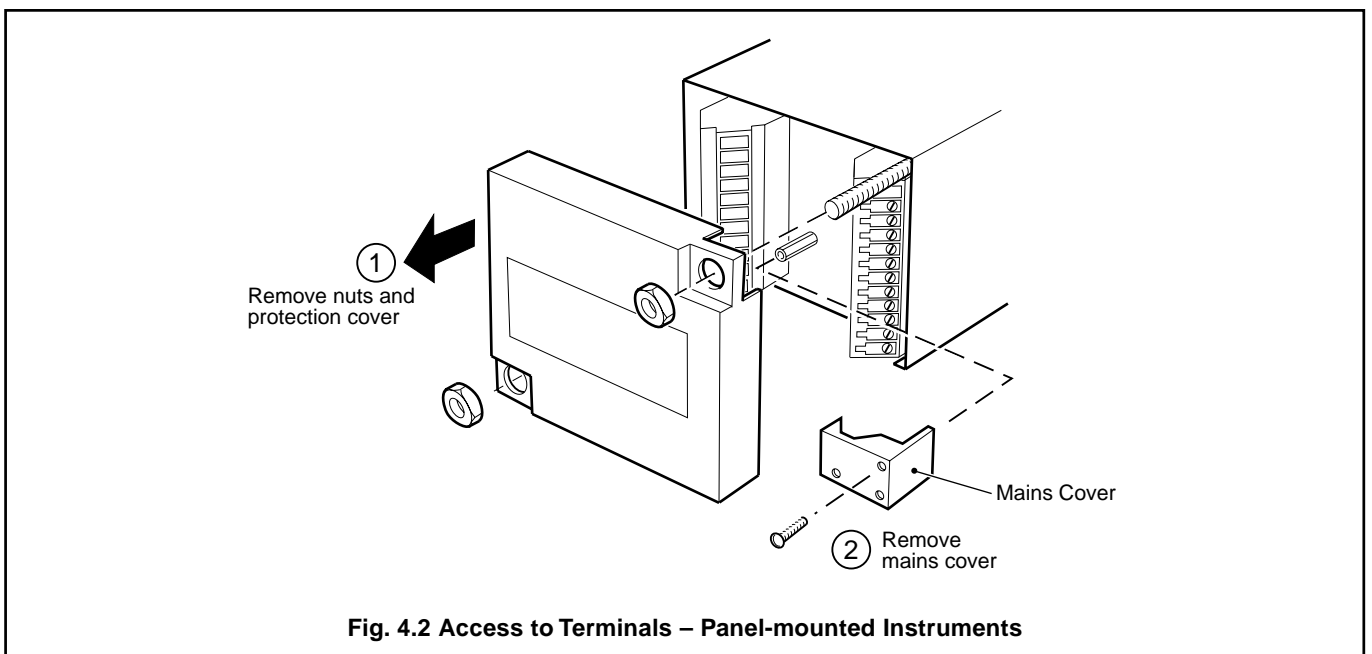

...4 ELECTRICAL CONNECTIONS

4.2 Connections, General



Information.

- **Earthing (grounding)** – stud terminal(s) is fitted to the transmitter case for bus-bar earth (ground) connection – see Fig. 4.1 or 4.5.
- **Cable lengths** – the integral cable may be extended using a suitable junction box, but the total cable length must not exceed 50m (for cells with a constant of <0.1) or 100m (for cells with a constant of ≥ 0.1).
- **Cable routing** – always route signal output/conductivity cell cable leads and mains-carrying/relay cables separately, ideally in earthed metal conduit. Employ twisted pair output leads or use screened cable with the screen connected to the case earth stud.

Ensure that the cables enter the transmitter through the glands nearest the appropriate screw terminals and are short and direct. Do not tuck excess cable into the terminal compartment.

- **Cable glands & conduit fittings** – ensure a moisture-tight fit when using cable glands, conduit fittings and blanking plugs/bungs (M20 holes). The M16 glands ready-fitted to wall-mounted instruments accept cable of between 4 and 7mm diameter.
- **Relays** – the relay contacts are voltage-free and must be appropriately connected in series with the power supply and the alarm/control device which they are to actuate. Ensure that the contact rating is not exceeded. Refer also to Section 4.2.1 (below) for relay contact protection details when the relays are to be used for switching loads.
- **Retransmission output** – Do not exceed the maximum load specification for the selected current retransmission range – see Section 10, **SPECIFICATION**.

Since the retransmission output is isolated the –ve terminal **must** be connected to earth (ground) if connecting to the isolated input of another device.

4.2.1 Relay Contact Protection and Interference Suppression – Fig. 4.3

If the relays are used to switch loads on and off, the relay contacts can become eroded due to arcing. Arcing also generates radio frequency interference (RFI) which can result in instrument malfunctions and incorrect readings. To minimise the effects of RFI, arc suppression components are required; resistor/capacitor networks for a.c. applications or diodes for d.c. applications. These components can be connected either across the load or directly across the relay contacts. On 4600 Series instruments the RFI components must be fitted to the relay terminal block along with the supply and load wires – see Fig 4.3.

For **a.c. applications** the value of the resistor/capacitor network depends on the load current and inductance that is switched. Initially, fit a 100R/0.022 μ F RC suppressor unit (part no. B9303) as shown in Fig. 4.3A. If the instrument malfunctions (locks up, display goes blank, resets etc.) the value of the RC network is too low for suppression and an alternative value must be used. If the correct value cannot be obtained, contact the manufacturer of the switched device for details on the RC unit required.

For **d.c. applications** fit a diode as shown in Fig. 4.3B. For general applications use an IN5406 type (600V peak inverse voltage at 3A – part no. B7363).



Note. For reliable switching the minimum voltage must be greater than 12V and the minimum current greater than 100mA.

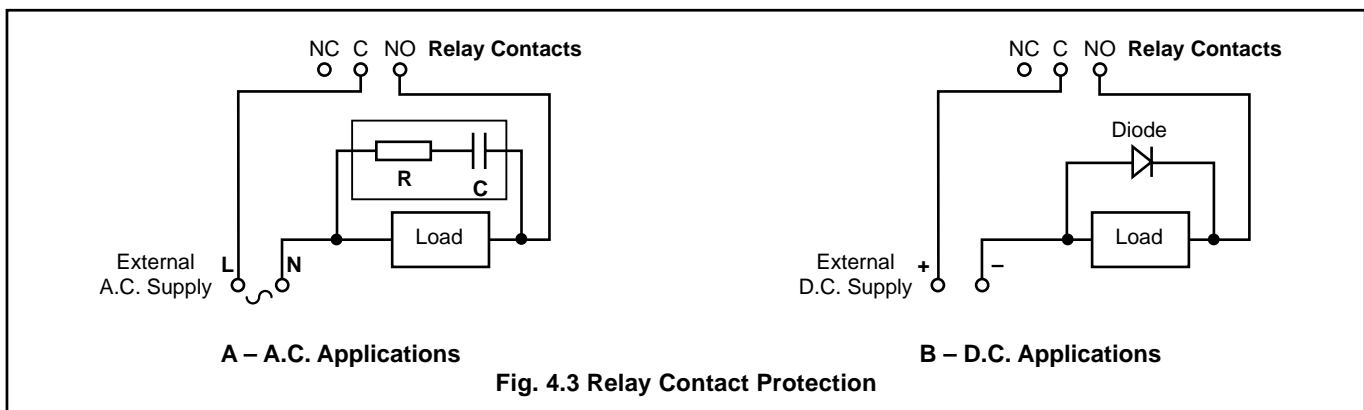

4.3 Wall-/Pipe-mounted Instrument Connections – Fig. 4.4

Note. Refer to Fig. 4.1 for Access to Terminals.

Caution. Slacken terminal screws fully before making connections.

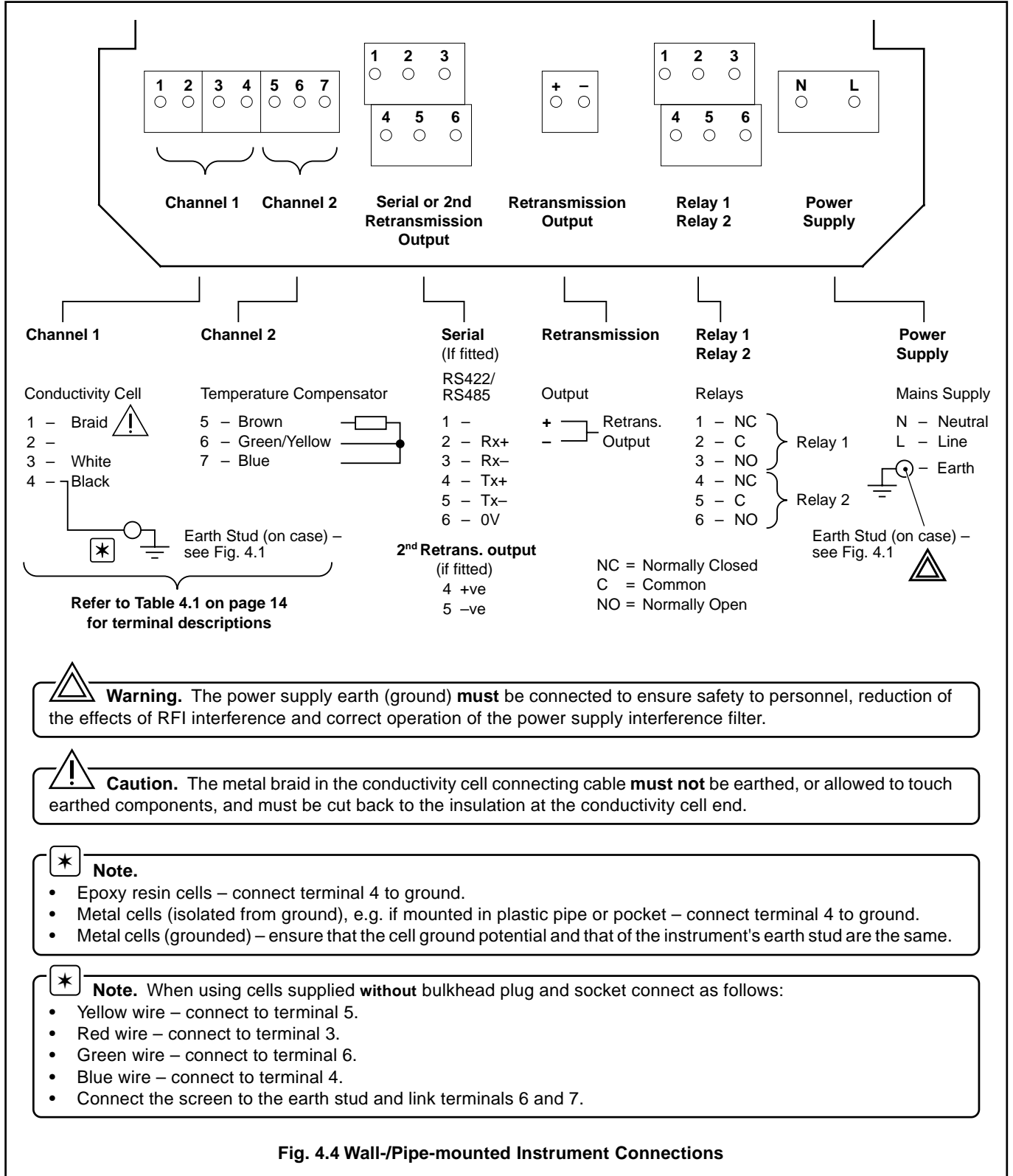

Warning. The power supply earth (ground) **must** be connected to ensure safety to personnel, reduction of the effects of RFI interference and correct operation of the power supply interference filter.

Caution. The metal braid in the conductivity cell connecting cable **must not** be earthed, or allowed to touch earthed components, and must be cut back to the insulation at the conductivity cell end.

Note.

- Epoxy resin cells – connect terminal 4 to ground.
- Metal cells (isolated from ground), e.g. if mounted in plastic pipe or pocket – connect terminal 4 to ground.
- Metal cells (grounded) – ensure that the cell ground potential and that of the instrument's earth stud are the same.

Note. When using cells supplied **without** bulkhead plug and socket connect as follows:

- Yellow wire – connect to terminal 5.
- Red wire – connect to terminal 3.
- Green wire – connect to terminal 6.
- Blue wire – connect to terminal 4.
- Connect the screen to the earth stud and link terminals 6 and 7.

Fig. 4.4 Wall-/Pipe-mounted Instrument Connections

...4 ELECTRICAL CONNECTIONS

4.4 Panel-mounted Instrument Connections – Fig. 4.5

Note. Refer to Fig. 4.2 for Access to Terminals.

Caution. Slacken terminal screws fully before making connections.

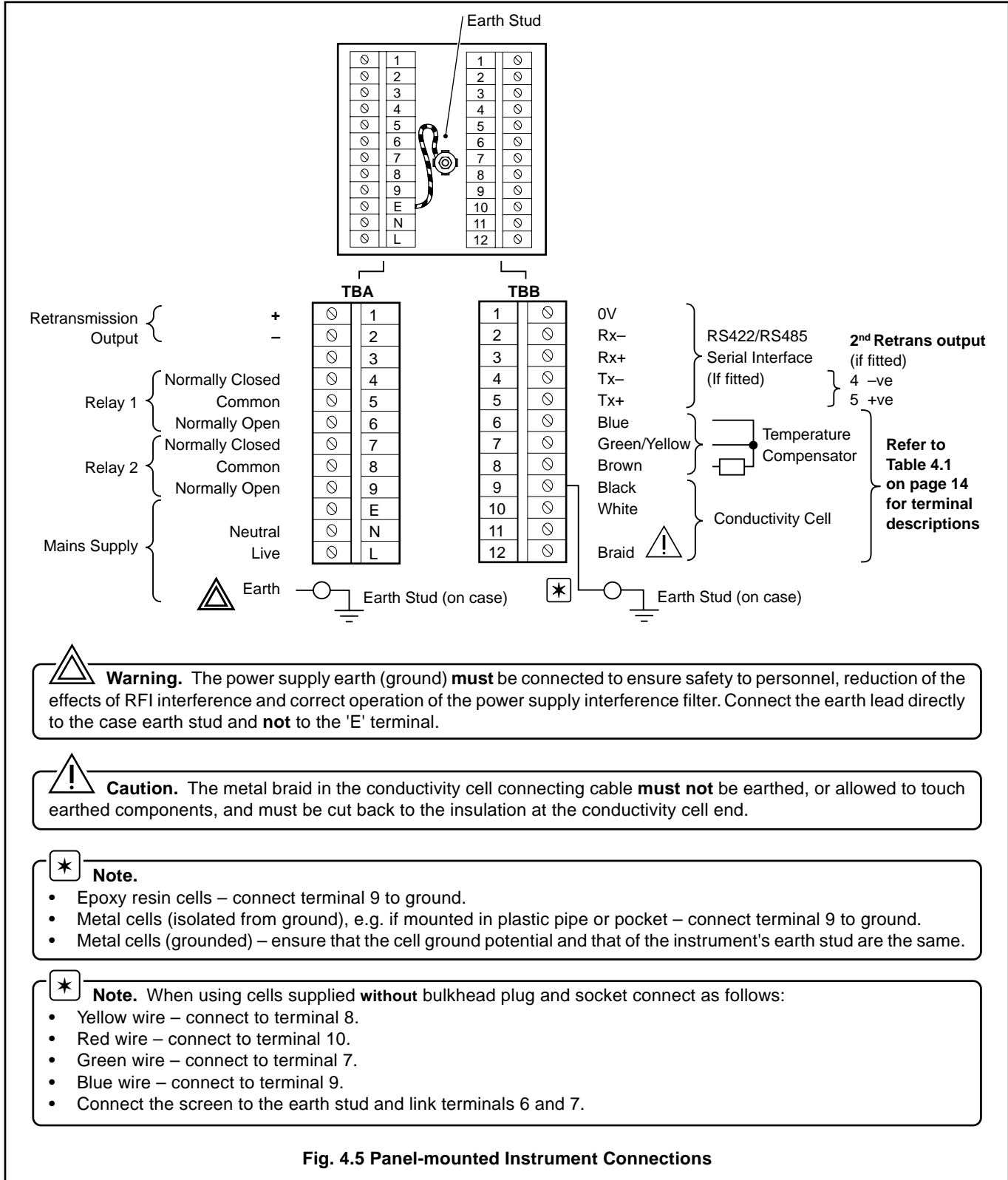

Warning. The power supply earth (ground) **must** be connected to ensure safety to personnel, reduction of the effects of RFI interference and correct operation of the power supply interference filter. Connect the earth lead directly to the case earth stud and **not** to the 'E' terminal.

Caution. The metal braid in the conductivity cell connecting cable **must not** be earthed, or allowed to touch earthed components, and must be cut back to the insulation at the conductivity cell end.

Note.

- Epoxy resin cells – connect terminal 9 to ground.
- Metal cells (isolated from ground), e.g. if mounted in plastic pipe or pocket – connect terminal 9 to ground.
- Metal cells (grounded) – ensure that the cell ground potential and that of the instrument's earth stud are the same.

Note. When using cells supplied **without** bulkhead plug and socket connect as follows:

- Yellow wire – connect to terminal 8.
- Red wire – connect to terminal 10.
- Green wire – connect to terminal 7.
- Blue wire – connect to terminal 9.
- Connect the screen to the earth stud and link terminals 6 and 7.

Fig. 4.5 Panel-mounted Instrument Connections

4.5 Selecting the Mains Voltage

4.5.1 Wall-/Pipe-mounted Instruments – Fig. 4.6

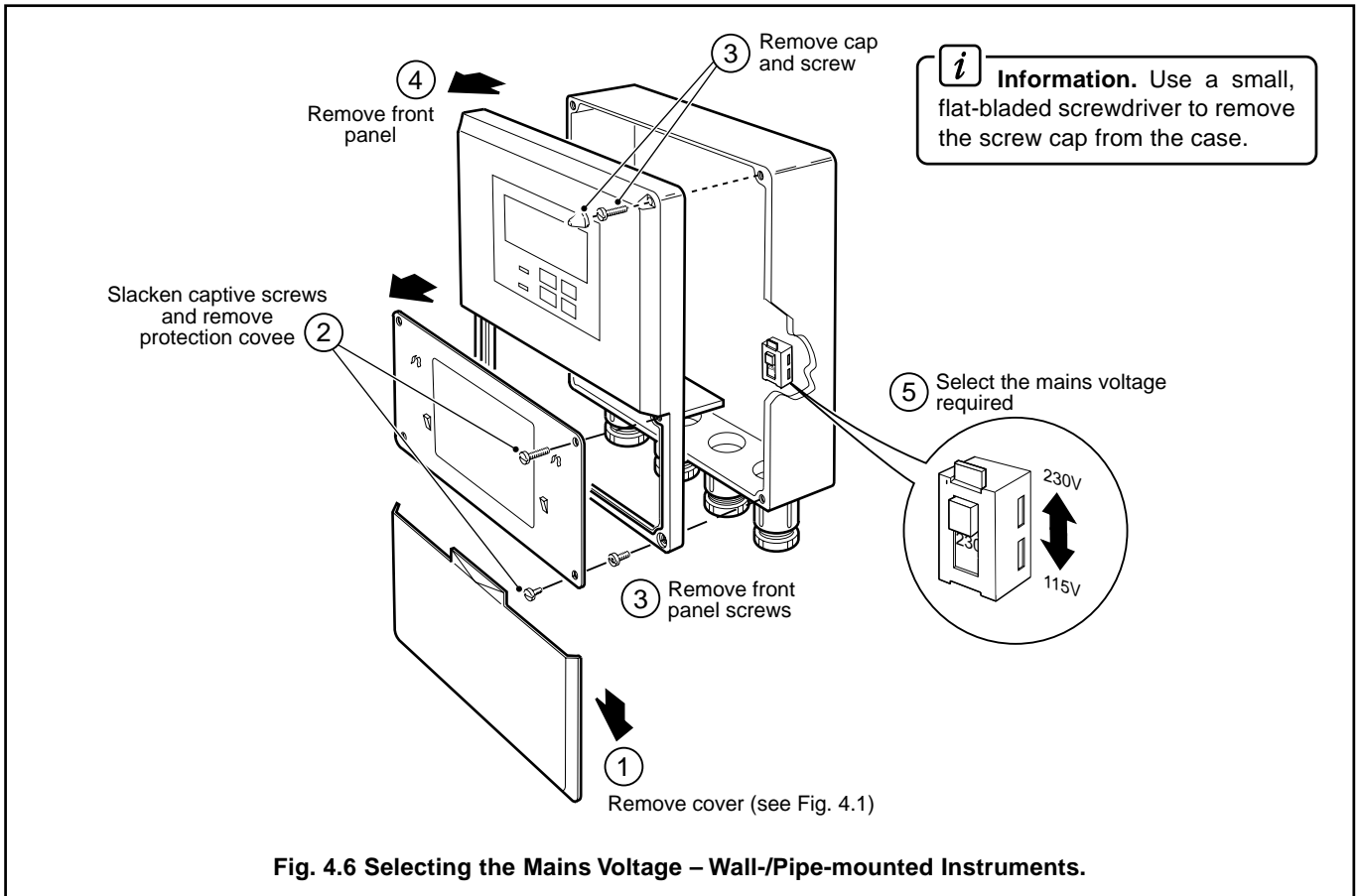

4.5.2 Panel-mounted Instruments – Fig. 4.7

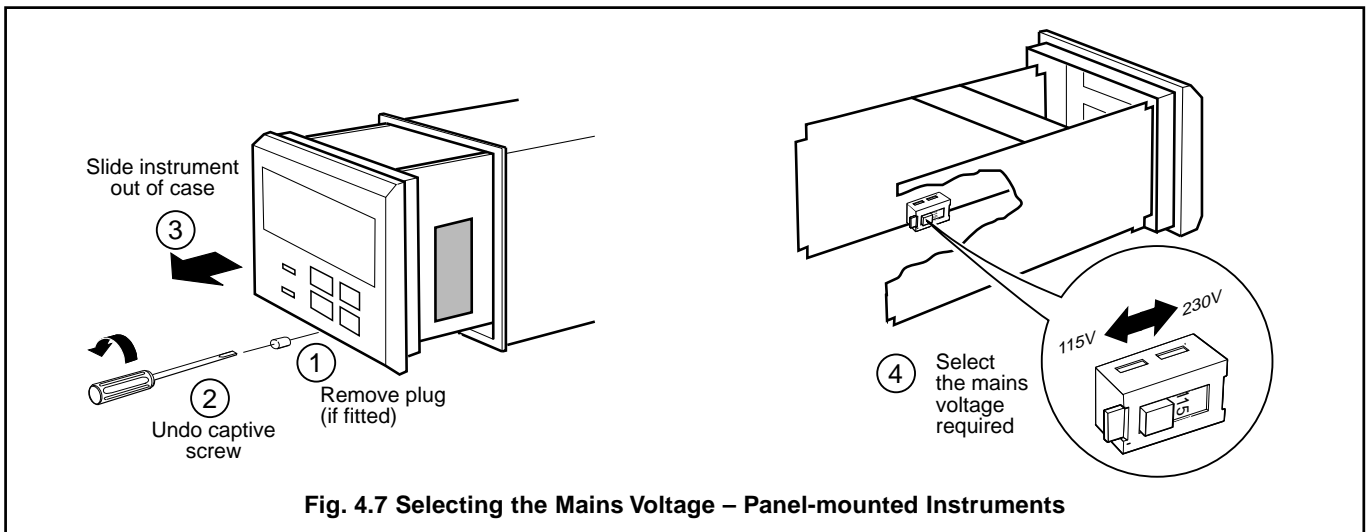

...4 ELECTRICAL CONNECTIONS

4.6 Conductivity Cell and Bulkhead Socket Connections – Fig. 4.8

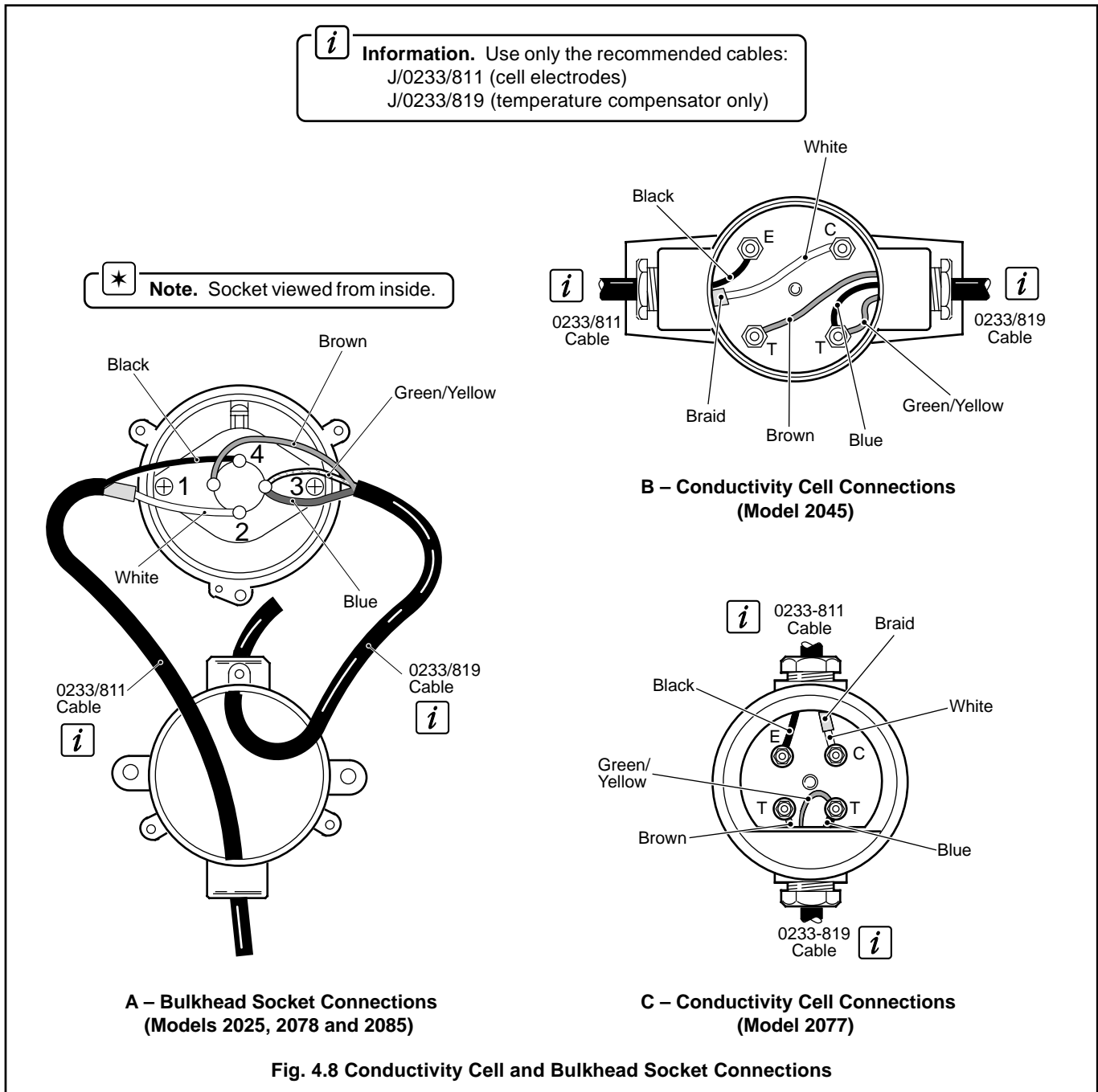

Instrument Type	Terminal Number						
Wall-mounted	1	2	3	4	5	6	7
Panel-mounted	12	11	10	9	8	7	6
	Driven screen output	N/A	Cell electrode input	Earth electrode input	PT100 input	PT100 3rd lead input	PT100 input

Table 4.1 Conductivity Cell and Temperature Compensator Terminal Descriptions

5 CONTROLS AND DISPLAYS

5.1 Displays – Fig. 5.1

The display comprises a 5-digit, 7-segment digital upper display line and a 16-character dot-matrix lower display line. The upper display line shows actual values of conductivity, temperature, alarm set points or programmable parameters. The lower display line shows the associated units or programming information.

5.2 Control Familiarisation

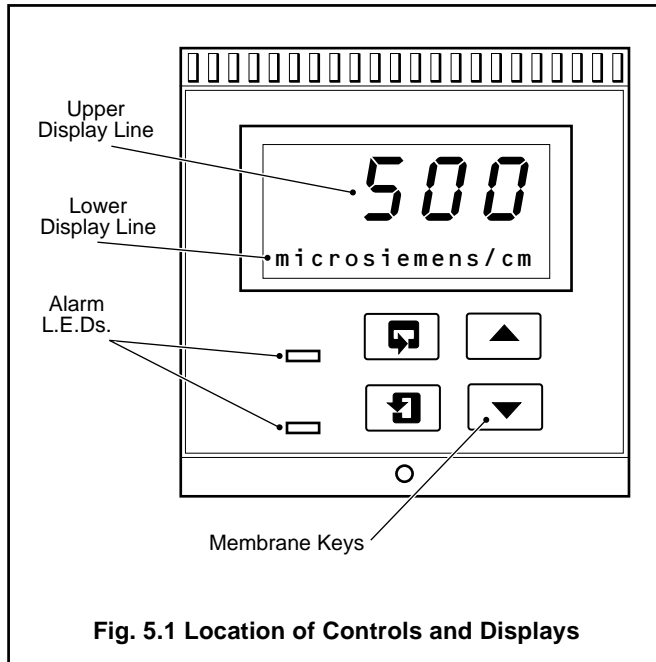

Fig. 5.1 Location of Controls and Displays

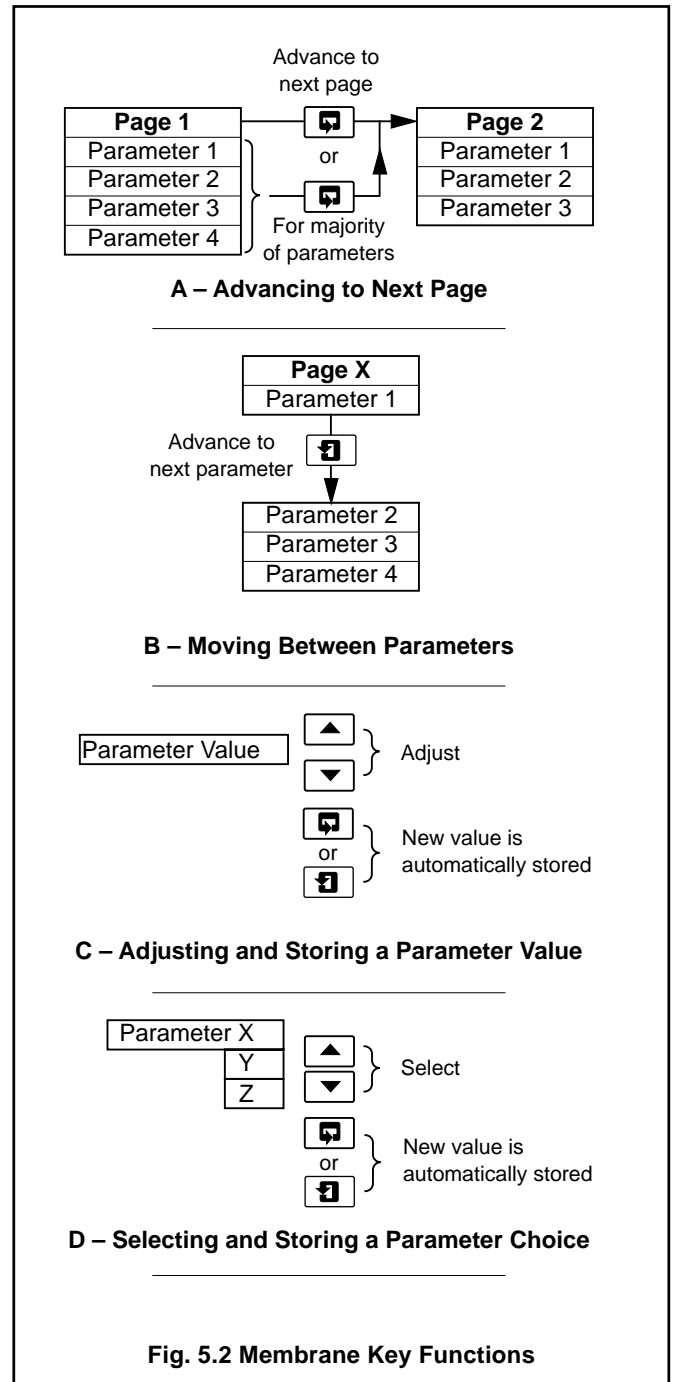

Fig. 5.2 Membrane Key Functions

6 OPERATION

6.1 Instrument Start-up

Ensure all electrical connections have been made correctly and switch on.

6.2 Operating Page

The **Operating Page** is a general use page in which parameters can be viewed but not altered. To alter or program a parameter refer to the programming pages in Section 7.

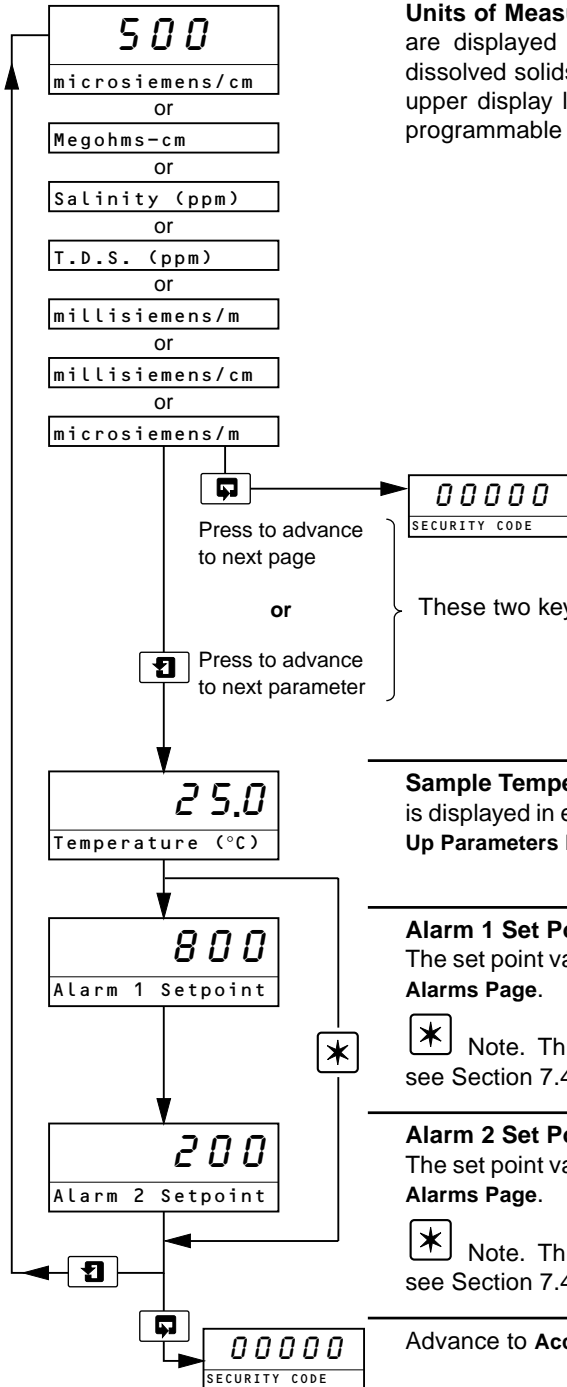

Units of Measured Value:

are displayed as any of four conductivity unit variants, resistance ($M\Omega\text{-cm}$), total dissolved solids (p.p.m.) or salinity (p.p.m.). The conductivity value is displayed on the upper display line and the conductivity units on the lower display line. The units are programmable within the limits detailed in Section 7.3, **Set Up Parameters Page**.

Sample Temperature:

is displayed in either $^{\circ}\text{C}$ or $^{\circ}\text{F}$. The display units are programmable – see Section 7.3, **Set Up Parameters Page**.

Alarm 1 Set Point:

The set point value and relay/l.e.d. action are programmable – see Section 7.4, **Set Up Alarms Page**.

Note. This display is bypassed if the Alarm Type has been set to FAIL or OFF – see Section 7.4, **Set Up Alarms Page**.

Alarm 2 Set Point:

The set point value and relay/l.e.d. action are programmable – see Section 7.4, **Set Up Alarms Page**.

Note. This display is bypassed if the Alarm Type has been set to FAIL or OFF – see Section 7.4, **Set Up Alarms Page**.

Advance to **Access to Secure Parameters** on page 18.

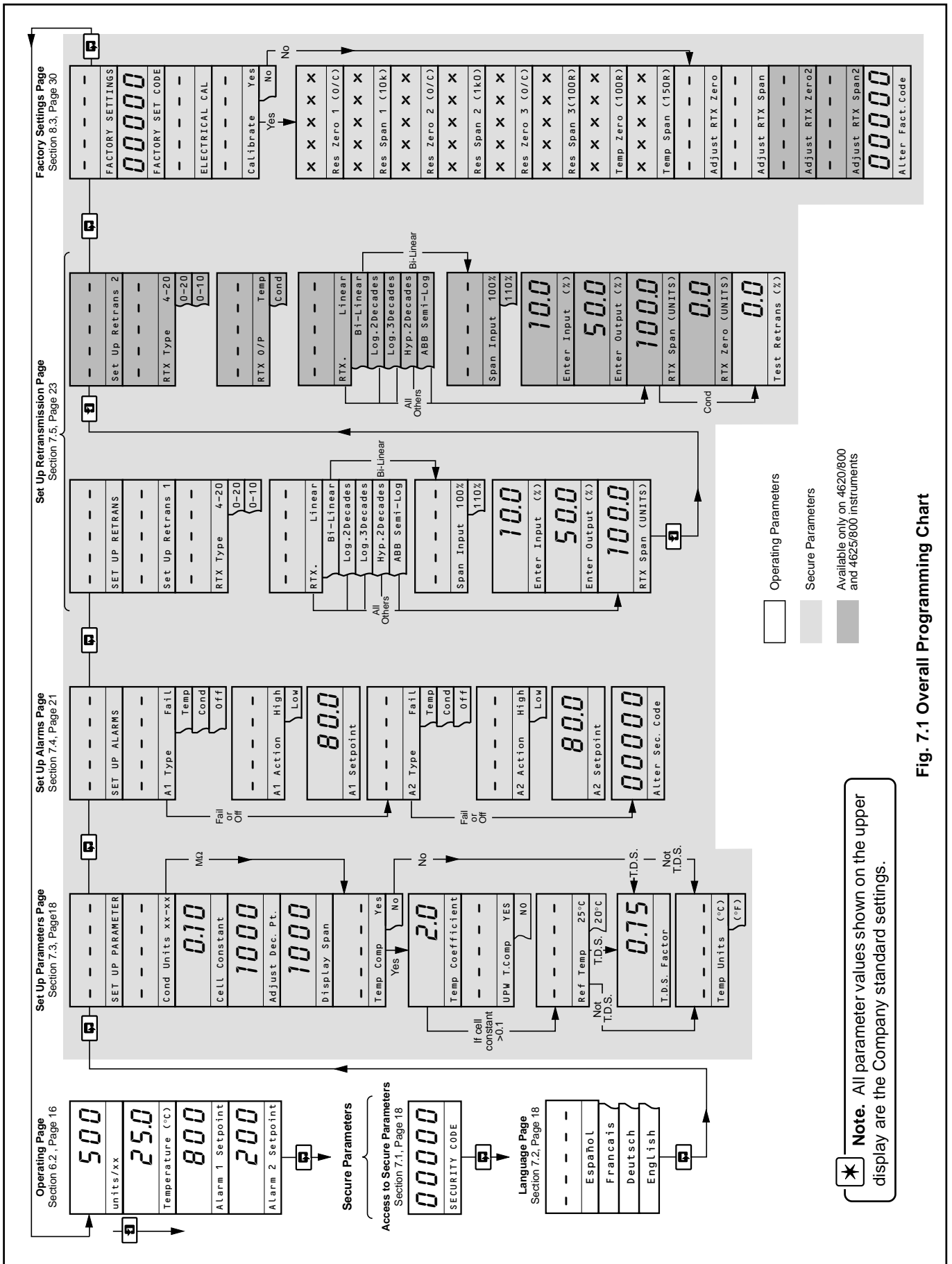
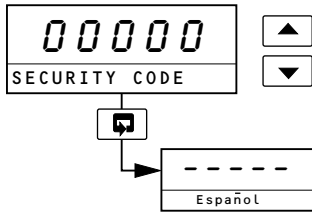

Fig. 7.1 Overall Programming Chart

...7 PROGRAMMING

7.1 Access to Secure Parameters

A 5-digit security code is used to prevent tampering with the secure parameters.



Security Code

Enter the required code number, between 00000 and 19999, to gain access to the secure parameters. If an incorrect value is entered, access to subsequent programming pages is prevented and the display reverts to the Operating Page.

Advance to **Language Page**.

7.2 Language Page

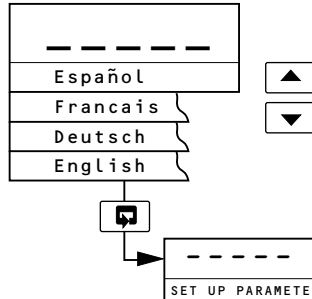

Language Page

Select the language to be displayed on all subsequent pages.

Advance to **Set Up Parameters Page**.

7.3 Set Up Parameters Page

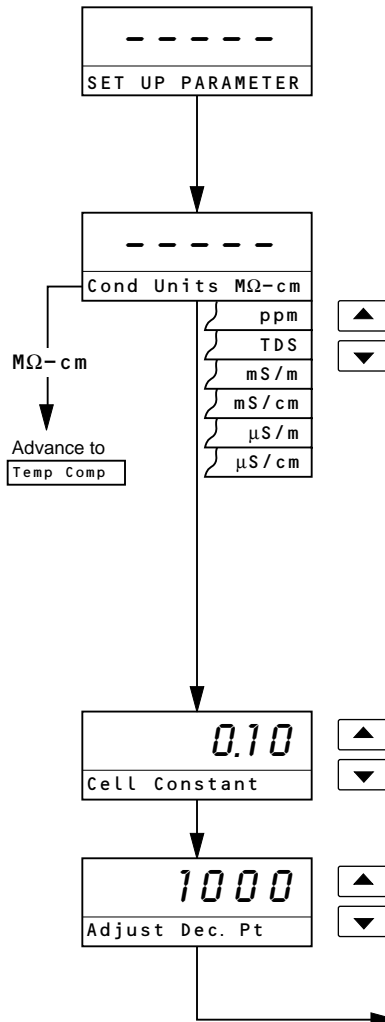

– press to advance to next parameter
or
 – press to advance to next page.

These two keys are used to advance to all subsequent parameters and pages. If a parameter is changed it is stored automatically on operation of either key.

Conductivity Units:

can be programmed to suit the range and application required. Select the required units, ensuring the range does not exceed the display limit of 10,000 μ S/cm:

M Ω -cm	–	Megohms-cm	
ppm	–	Salinity	(see Table 7.2 opposite)
TDS	–	Total Dissolved Solids	(see Table 7.3 opposite)
mS/m	–	Millisiemens/m	} (see Table 7.1 opposite)
mS/cm	–	Millisiemens/cm	
μ S/m	–	Microsiemens/m	
μ S/cm	–	Microsiemens/cm	

Note. Conductivity unit selections are limited by the conductivity span (see **Display Span** parameter on page 20) and/or the cell constant (see Table 7.1, 7.2, or 7.3).

If M Ω -cm is selected the following parameters are set automatically:
Cell Constant = 0.05 **Display Span** = 20M Ω **Retransmission 2 Zero** = 2M Ω

Cell Constant:

determines the limits for the conductivity range and units – see Table 7.1, 7.2, or 7.3.

Enter the cell constant for the type of measuring cell in use – see Section 2.1.3.

Decimal Point Position

Set the decimal point position to obtain the required resolution for the chosen conductivity range.

Example – for a range of 0 to 500 μ S/cm set the decimal point to 'x x x . x' or 'x x x'.

Continued on page 20.

...7.3 Set Up Parameters Page

Conductivity Cell Constant (K)	Minimum Conductivity Range	Maximum Conductivity Range
0.05	0 to 0.5µS/cm 0 to 50µS/m	0 to 500µS/cm 0 to 10,000µS/m
0.1	0 to 1µS/cm 0 to 100µS/m 0 to 0.1mS/m	0 to 1,000µS/cm 0 to 10,000µS/m 0 to 100mS/m
1.0	0 to 10µS/cm 0 to 1,000µS/m 0 to 0.01mS/cm 0 to 1mS/m	0 to 10,000µS/cm 0 to 10,000µS/m 0 to 10mS/cm 0 to 1,000mS/m

For cells with a constant (K) other than those specified, the conductivity range limits can be calculated from the following:
 Minimum conductivity range is $K \times 10$ (µS/cm).
 Maximum conductivity range is $K \times 10,000$ (µS/cm).

i **Information.** 100µS/m = 1µS/cm
 1mS/cm = 1000µS/cm

Table 7.1 Conductivity Range Limits for Different Cell Constants (K)

Conductivity Cell Constant (K)	Salinity Factor (Preset)	Maximum Salinity Range (p.p.m.)
0.1	0.5	0 to 500
1.0	0.5	0 to 5,000

For cells with a constant (K) other than 0.1 or 1.0 the maximum Salinity range (p.p.m.) can be calculated using $K \times 5,000$.

Table 7.2 Salinity Range Limits for Different Cell Constants (K)

Conductivity Cell Constant (K)	Maximum Conductivity Range (µS/cm)	Maximum Effective T.D.S. Range (p.p.m.)				
		T.D.S. Factor (examples)				
		0.40	0.50	0.60	0.70	0.80
0.1	0 to 1,000	0 to 400	0 to 500	0 to 600	0 to 700	0 to 800
1.0	0 to 10,000	0 to 4,000	0 to 5,000	0 to 6,000	0 to 7,000	0 to 8,000

For cells with a constant (K) other than 0.1 or 1.0 the maximum T.D.S. range can be calculated using $K \times 10,000 \times \text{T.D.S. factor}$.

Table 7.3 T.D.S. Range Limits for Different Cell Constants (K)

...7 PROGRAMMING

...7.3 Set Up Parameters Page

Display Span (Full Scale)
Set the full scale value required, within the limits dictated by the previously programmed cell constant.

Example – for a range of 0 to 500 μ S/cm, set to 500.0 or 500.

Temperature Compensation:
for fluctuations in the sample temperature can be switched in or out, as required. Select **Yes** to switch in or **No** to switch out.

Note. If **M Ω -cm** is selected (see page 18) and **Temperature Compensation** is set to **Yes**, **U.P.W. Temperature Compensation** is selected automatically (see below).

Temperature Coefficient
If unknown, the temperature coefficient (∞) of the solution can be calculated – see Appendix A1.1.

Enter the temperature coefficient ($\infty \times 100$) of the solution (0.0 to 3.0%/°C). If the value has not yet been calculated, provisionally set it to 2%/°C (0.020).

Ultra-pure Water (U.P.W.) Temperature Compensation
Additional temperature compensation may be required if the sample conductivity approaches that of ultra-pure water, i.e. low conductivity (see Appendix A1). This facility can be utilised only when using one of the Company's range of ultra-pure water conductivity cells with a cell constant (K) of 0.05 or 0.10.

Select either **Yes** or **No**.

Reference Temperature
Enter the required reference temperature as either 25°C (77°F) or 20°C (68°F).

T.D.S. Factor
The T.D.S. factor must be programmed to suit the particular application – see Appendix A2.

Note. The display span is limited by the cell constant. It is important that the programmed T.D.S. factor does not cause the range of the instrument to exceed the programmed span limits – see Table 7.3, previous page.

Enter the required T.D.S. factor between 0.4 and 0.8.

Example – for a cell constant of 1.0 and a programmed range of 0 to 5000 p.p.m.:

T.D.S. factors of 0.50 to 0.80 are permissible.

A T.D.S. factor of 0.40 exceeds the programmed range.

Temperature Units
The sample temperature (and reference temperature) can be displayed as either degrees Fahrenheit or Celsius.

Select either °C or °F.

Return to top of page

Advance to **Set Up Alarms Page**.

7.4 Set Up Alarms Page

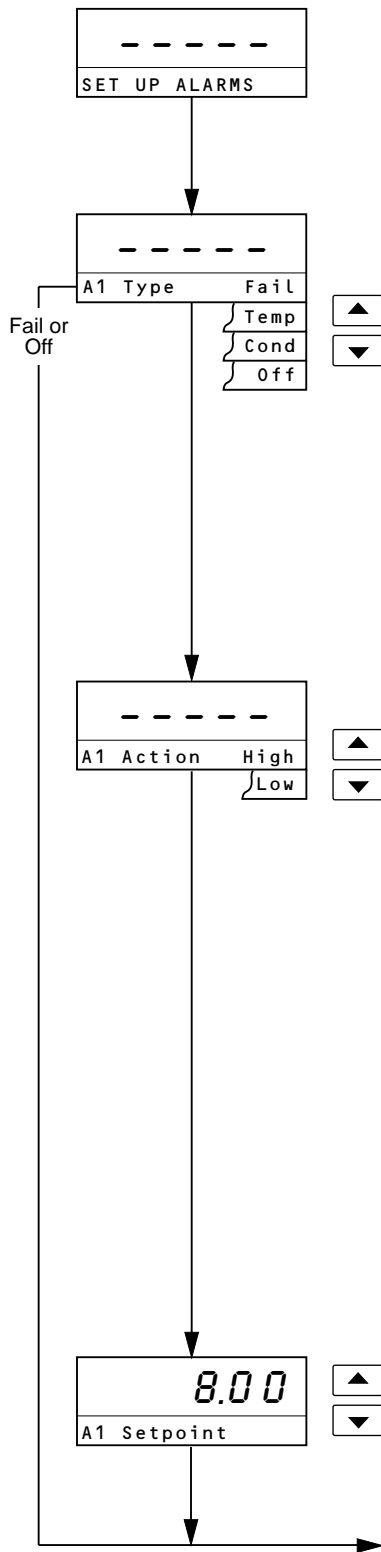

- press to advance to next parameter
or
- press to advance to next page.

These two keys are used to advance to all subsequent parameters and pages. If a parameter is changed it is automatically stored on operation of either key.

Alarm 1 Type

Select the type of alarm required. For **F a i l**, **T e m p** and **C o n d** alarm types, the alarm l.e.d. is off and the relay energized during normal conditions. In a fail condition, the l.e.d. is on and the relay de-energized.

- F a i l** – The instrument alerts the operator to either a power failure or a condition that causes any of the error messages listed in Table 9.1 to be displayed.
- T e m p** – The instrument alerts the operator if the temperature of the process fluid exceeds or drops below the value set in the **Alarm 1 Set Point** parameter, depending on the type of **Alarm 1 Action** selected below.
- C o n d** – The instrument alerts the operator if the conductivity of the process fluid exceeds or drops below the value set in the **Alarm 1 Set Point** parameter, depending on the type of **Alarm 1 Action** selected below.
- O f f** – If selected, no alarms are set and the alarm l.e.d. is off and the relay de-energized at all times.

Alarm 1 Action

For '**Fail-safe**' alarm operation the relay's alarm state must be the same as the power-down state, i.e. the relay is de-energised.

- For **H i g h** alarm operation the relay must be energized below the alarm set point.
- For **L o w** alarm operation the relay must be energized above the alarm set point.

The alarm l.e.d.s are illuminated in the alarm condition.

Select the required alarm 1 action from the following table:

Alarm Action	LED Condition for Input Above Set Point	LED Condition for Input Below Set Point	Relay Condition for Input Above Set Point	Relay Condition for Input Below Set Point
High	ON	OFF	De-energized	Energized
Low	OFF	ON	Energized	De-energized

The set point band is defined as the actual value of the set point plus or minus the hysteresis value. The hysteresis value is $\pm 1\%$ of the Alarm 1 set point value. Alarm action occurs if the input value is above or below the set point band. If the input moves within the set point band the last alarm action is maintained.

Alarm 1 Set Point

The alarm 1 set point can be set to any value within the input range being displayed. The set point value is subject to hysteresis as detailed above.

Set the alarm set point to the required value.

Continued on next page.

...7 PROGRAMMING

...7.4 Set Up Alarms Page

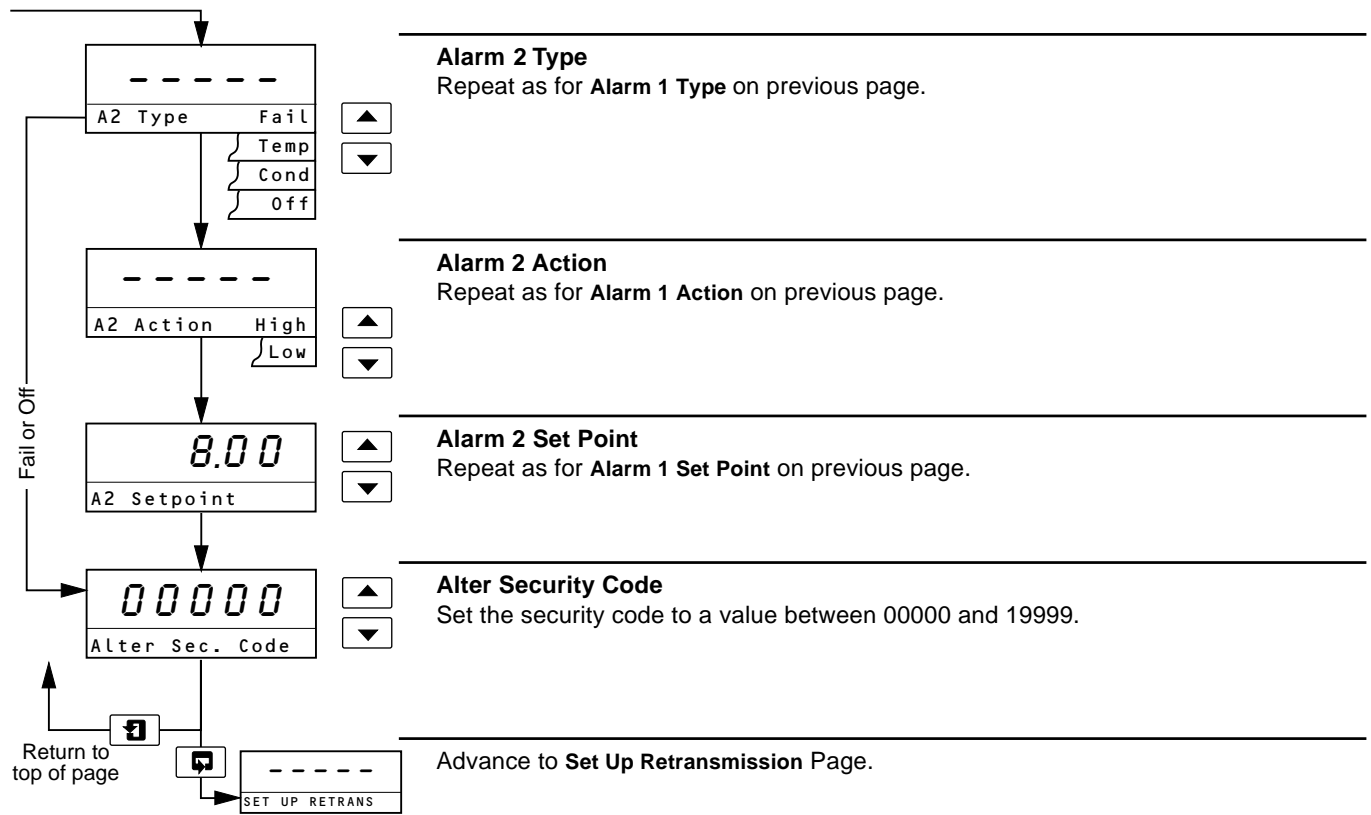

7.5 Set Up Retransmission Page

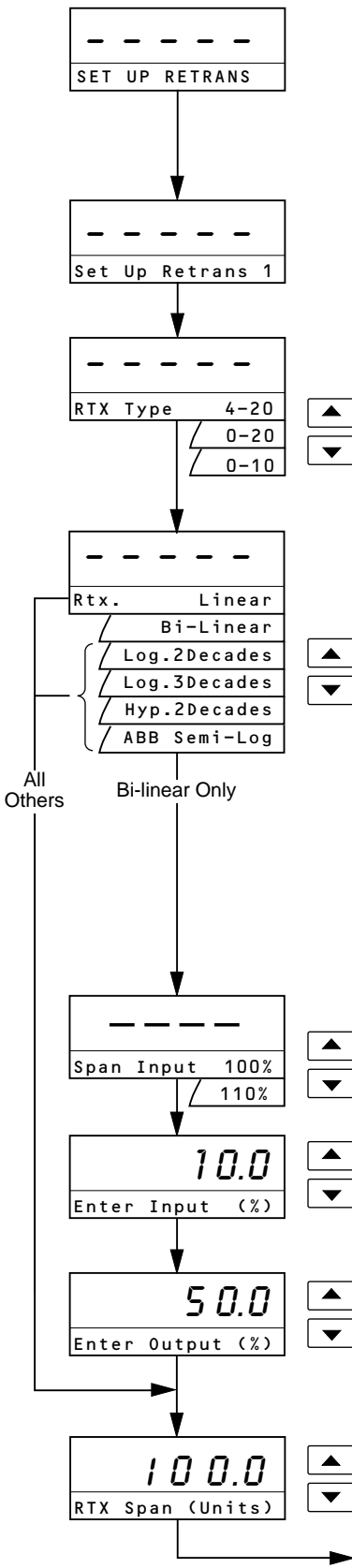

– press to advance to next parameter
 or
 – press to advance to next page.

These two keys are used to advance to all subsequent parameters and pages. If a parameter is changed it is automatically stored on operation of either key.

Set Up Retransmission 1

Retransmission 1 Output Range

Set the retransmission output current range for retransmission channel 1.

Retransmission 1 Output Scale

Select the retransmission output scale required.

Note. If Conductivity Units has been set to $M\Omega-cm$ in the **Set Up Parameters Page**, the instrument automatically sets Retransmission 1 Output Scale to *Linear* and Retransmission 1 Span to 2.00 to 20.00 $M\Omega-cm$.

- Linear*
- Bi-Linear* – see Section 7.6, Fig. 7.2
- Log.2Decades* – Logarithmic, 2-decades – see Section 7.6, Fig. 7.3
- Log.3Decades* – Logarithmic, 3-decades – see Section 7.6, Fig. 7.4
- Hyp.2Decades* – Hyperbolic, 2-decades – see Section 7.6, Fig. 7.5
- ABB Semi-Log* – ABB Semi-logarithmic – see Section 7.6, Fig. 7.6

Note. The output scale is calculated as a percentage of the retransmission 1 output span. Ensure that the retransmission 1 output span has been set correctly – see below.

Span Input

Set the percentage of the display span over which the output is to be scaled to 100 or 110%. This is Point A on Fig. 7.2.

Enter Input %

Set the percentage of the display span at which the breakpoint occurs to between 0.1 and 100% in 0.1% increments. This is Point B on Fig. 7.2.

Enter Output %

Set the percentage output at which the breakpoint occurs to between 0.0 and 100% in 0.1% increments. This is Point C on Fig. 7.2.

Set the alarm type to the required setting.

Retransmission 1 Span

Set the required span over which the retransmission output is to operate to between 10 and 100% of the display span – see Section 7.3, **Set Up Parameters Page**.

Continued on next page.

...7 PROGRAMMING

...7.5 Set Up Retransmission Page

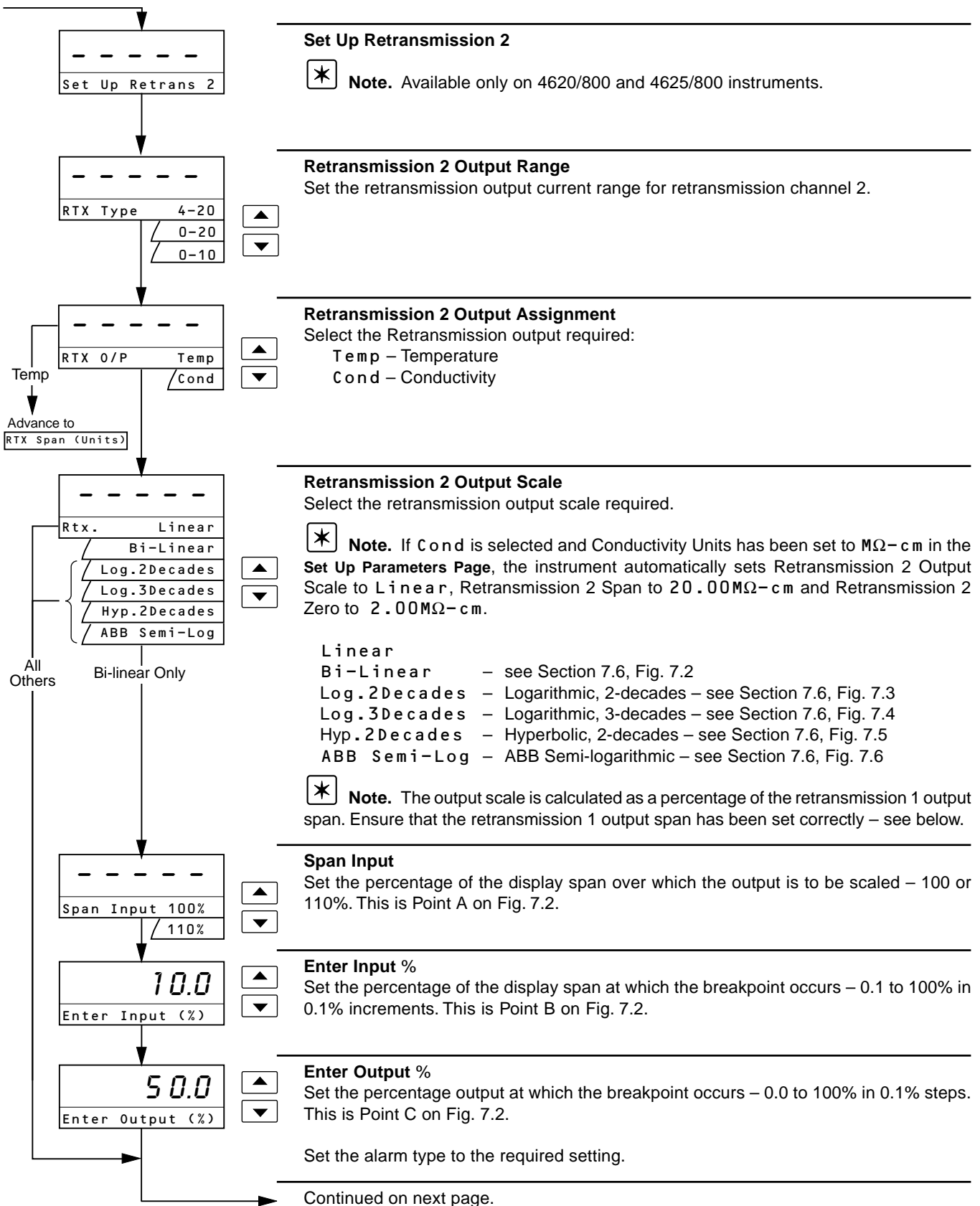

...7.5 Set Up Retransmission Page

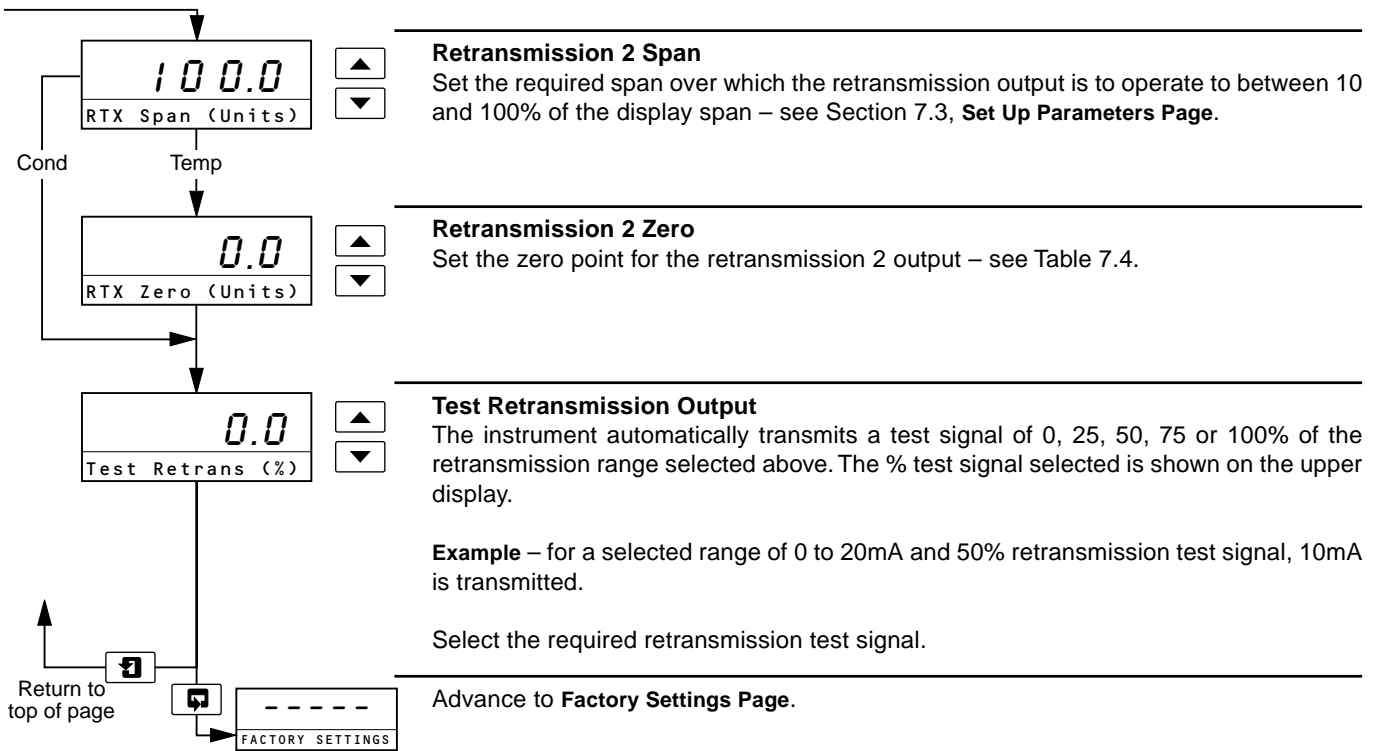

Retransmission 2 Output Assignment	Retransmission 2 Span	Retransmission 2 Zero
Conductivity (If Conductivity Units set to MΩ-cm)	programmable between 10 and 100% of display span 20.00 (set automatically)	Set automatically according to selected Retransmission Output 2 Scale: Linear = 0 Bi-linear = 0 Log. 2 Decades = 1.0% of Retransmission 2 Span Log. 3 Decades = 0.1% of Retransmission 2 Span Hyp. 2 Decades = 1.0% of Retransmission 2 Span ABB Semi-Log = 0.1% of Retransmission 2 Span 2.00 (set automatically)
Temperature (°C)	150 (max.) (subject to minimum range of 20°C)	-10 (min.)
Temperature (°F)	302 (max.) (subject to minimum range of 36°F)	14 (min.)

Table 7.4 Retransmission 2 Zero

...7 PROGRAMMING

7.6 Output Functions

7.6.1 Bi-linear Output – Fig. 7.2

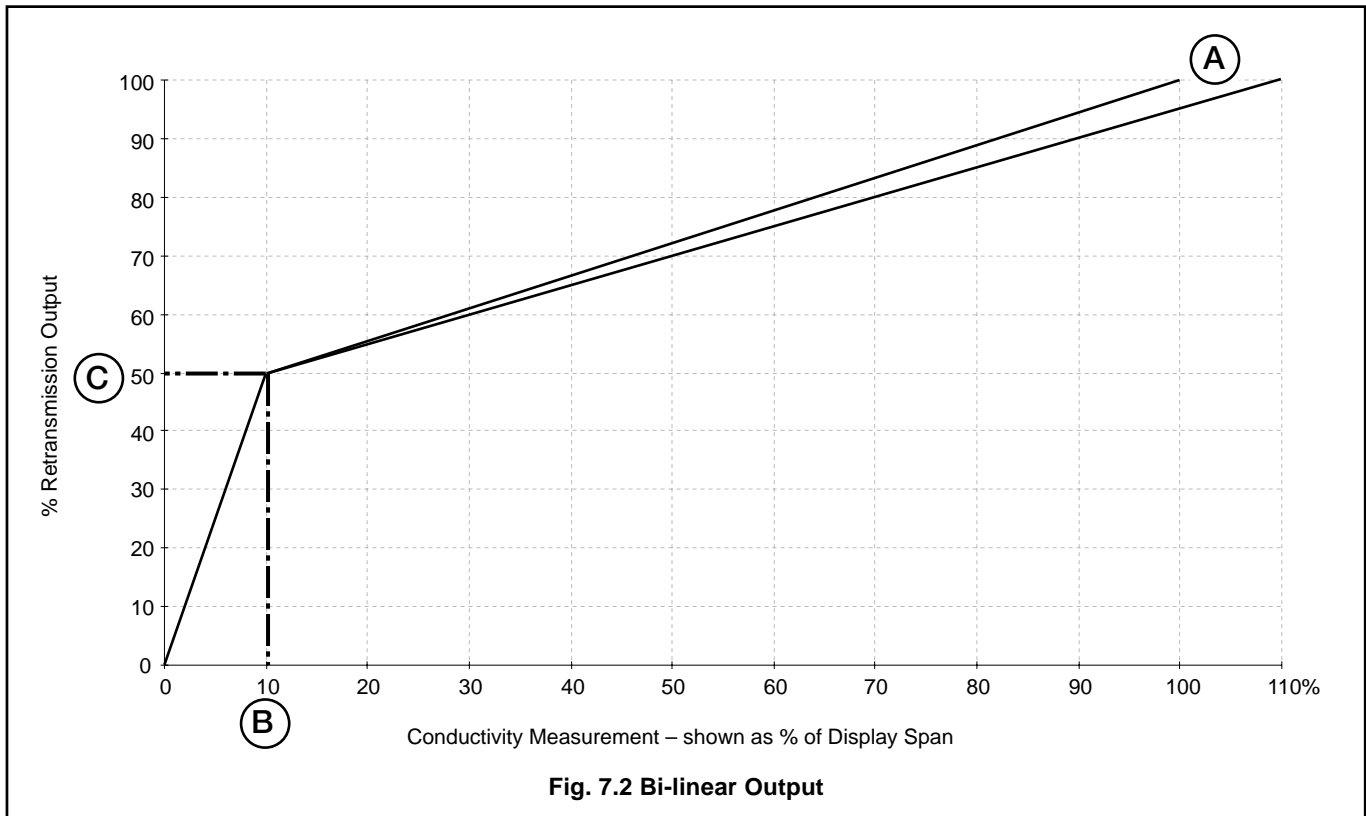

7.6.2 2-decade Logarithmic Output – Fig. 7.3

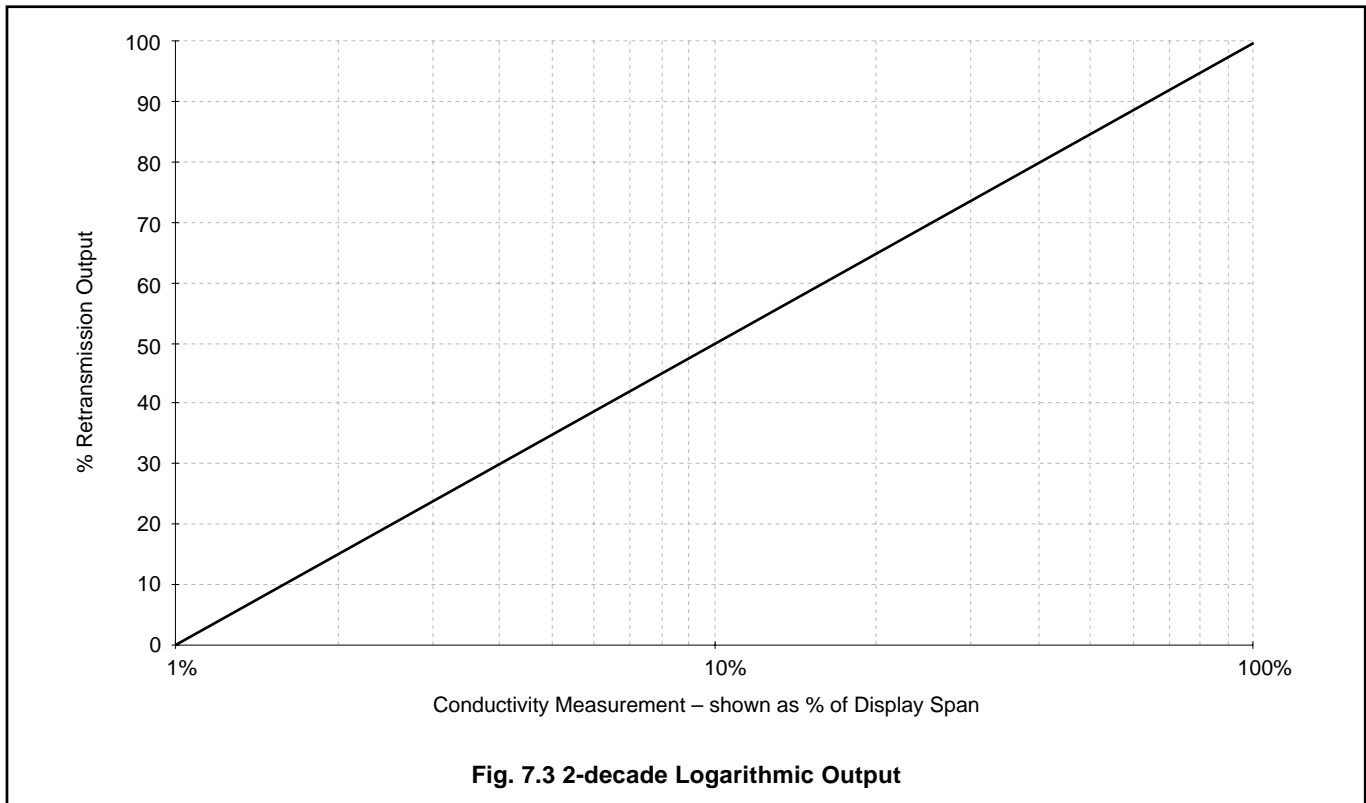

...7.6 Output Functions

7.6.3 3-decade Logarithmic Output – Fig. 7.4

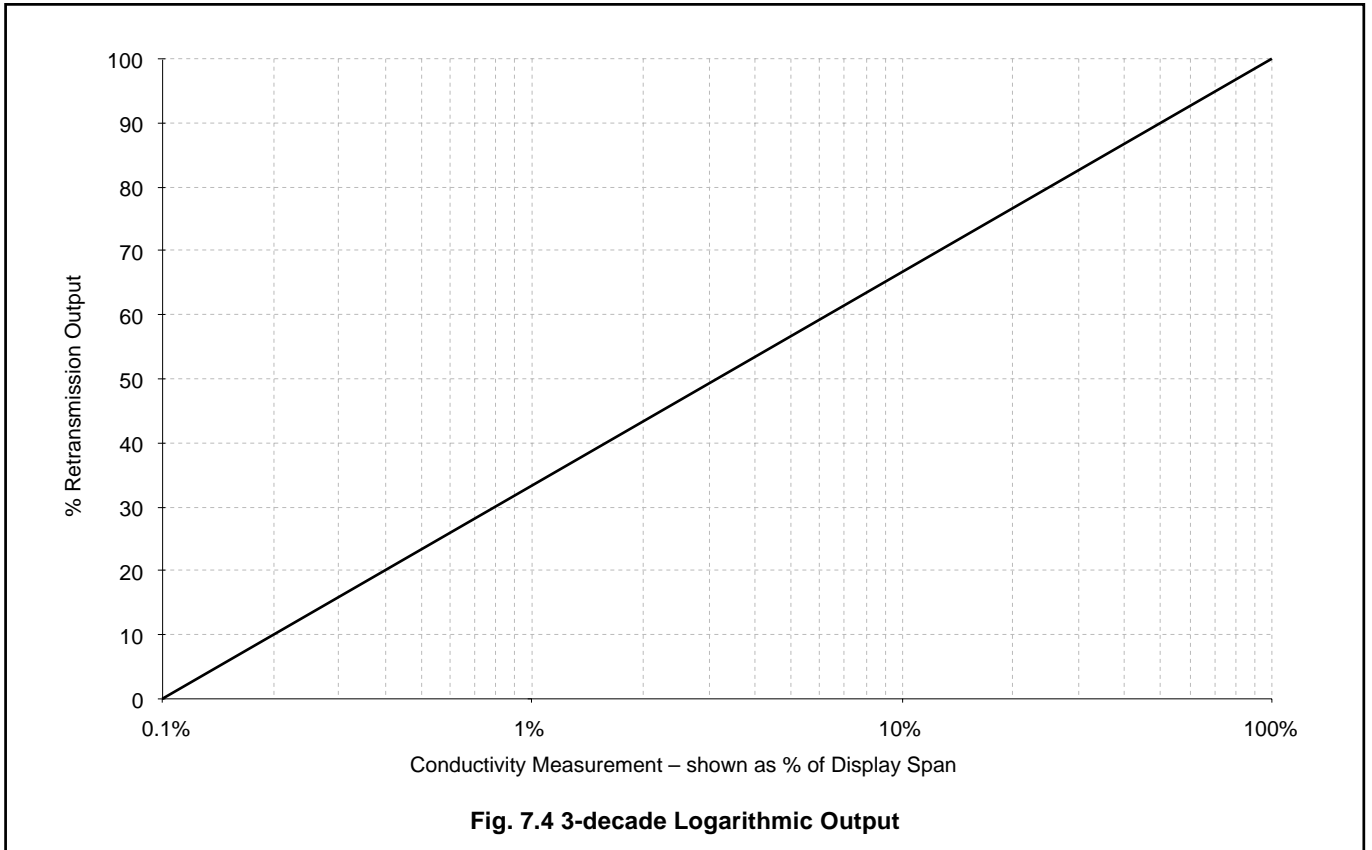

7.6.4 2-decade Hyperbolic Output – Fig. 7.5

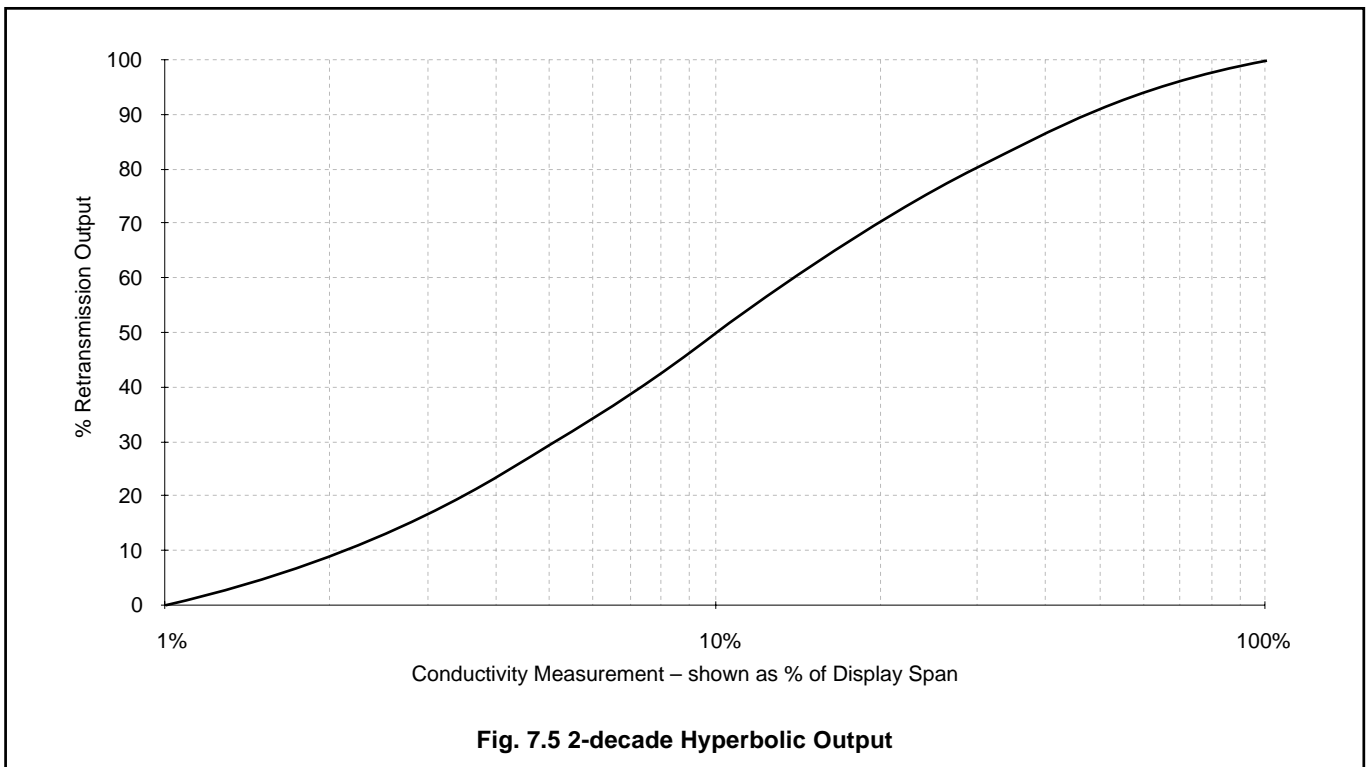

...7 PROGRAMMING

...7.6 Output Functions

7.6.5 ABB Semi-logarithmic Output – Fig. 7.6

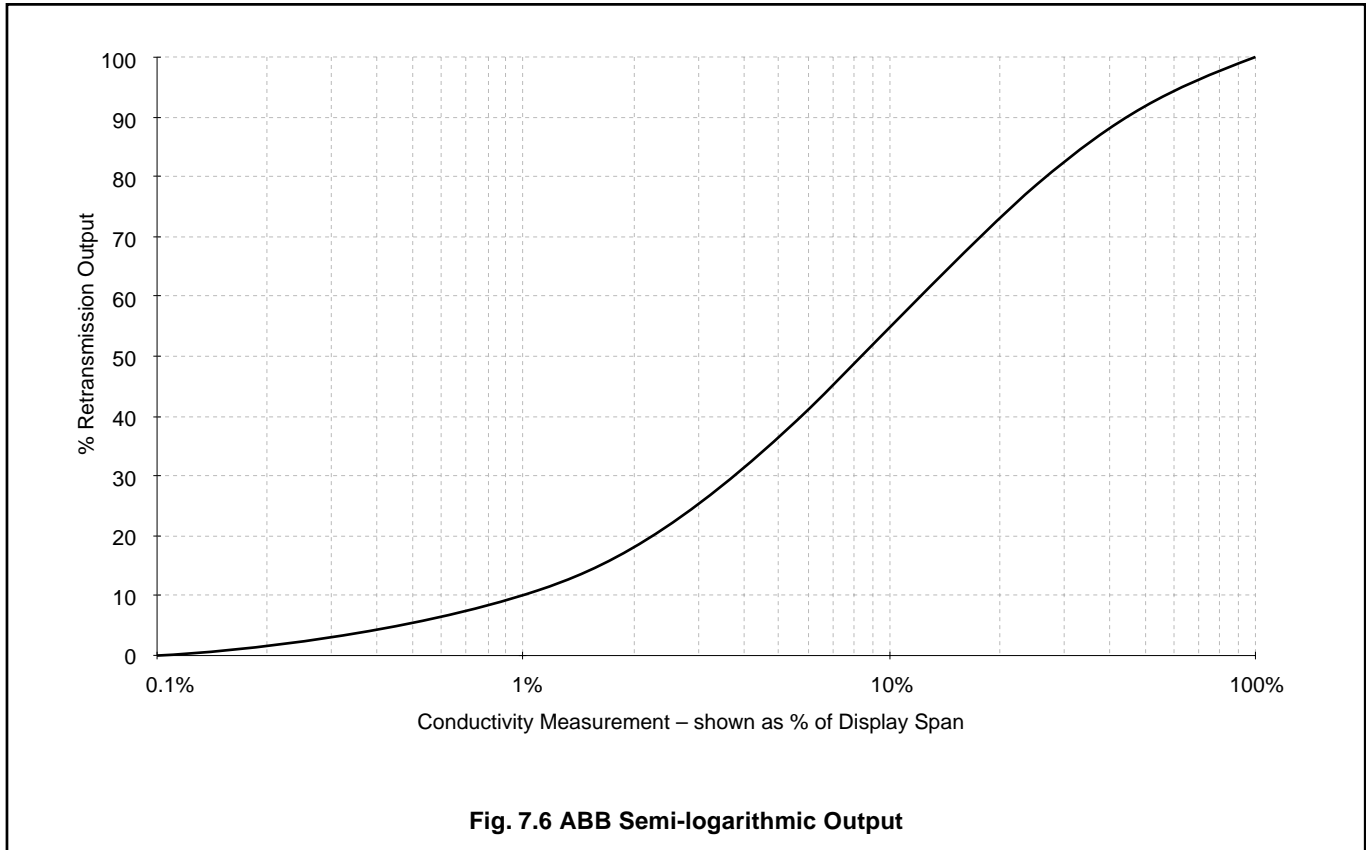

8 CALIBRATION



Note. The instrument is calibrated by the Company prior to despatch and recalibration should be carried out **only** if the instrument's accuracy is suspect **and** suitably calibrated test equipment is available.

8.1 Equipment Required

- Decade resistance box (conductivity cell input simulator): 0 to 10k Ω (in increments of 0.1 Ω), accuracy $\pm 0.1\%$.
- Decade resistance box (PT100 temperature input simulator): 0 to 1k Ω (in increments of 0.01 Ω), accuracy $\pm 0.1\%$.
- Digital milliammeter (current output measurement): 0 to 20mA.



Note. Resistance boxes have an inherent residual resistance which may range from a few m Ω up to 1 Ω . This value must be taken into account when simulating input levels, as should the overall tolerance of the resistors within the boxes.

8.2 Preparation

- Switch off the supply and disconnect the conductivity cell, PT100 temperature compensator and current output from the instrument's terminal blocks – see Fig. 4.4 (page 11) or Fig. 4.5 (page 12).

b) Wall-mounted Instruments (Fig 8.1A):

- Link terminals 6 & 7.
- Link terminal 4 to the Case Earth Stud.
- Connect the 0 to 10k Ω decade resistance box to terminals 3 & 4 to simulate the conductivity cell. Connect the decade box earth to the Case Earth Stud.
- Connect the 0 to 1k Ω decade resistance box to terminals 5 & 7 to simulate the PT100.
- Connect the milliammeter to the retransmission output terminals – see Fig. 4.4 (page 11).

Panel-mounted Instruments (Fig 8.1B):

- Link terminals 6 & 7.
- Link terminal 9 to the Case Earth Stud.
- Connect the 0 to 10k Ω decade resistance box to terminals 9 & 10 to simulate the conductivity cell. Connect the decade box earth to the Case Earth Stud.
- Connect the 0 to 1k Ω decade resistance box to terminals 6 & 8 to simulate the PT100.
- Connect the milliammeter to the retransmission output terminals – see Fig. 4.5 (page 12).

- Switch on the supply and allow ten minutes for the circuits to stabilize.

- Select the FACTORY SETTINGS page and carry out Section 8.3.

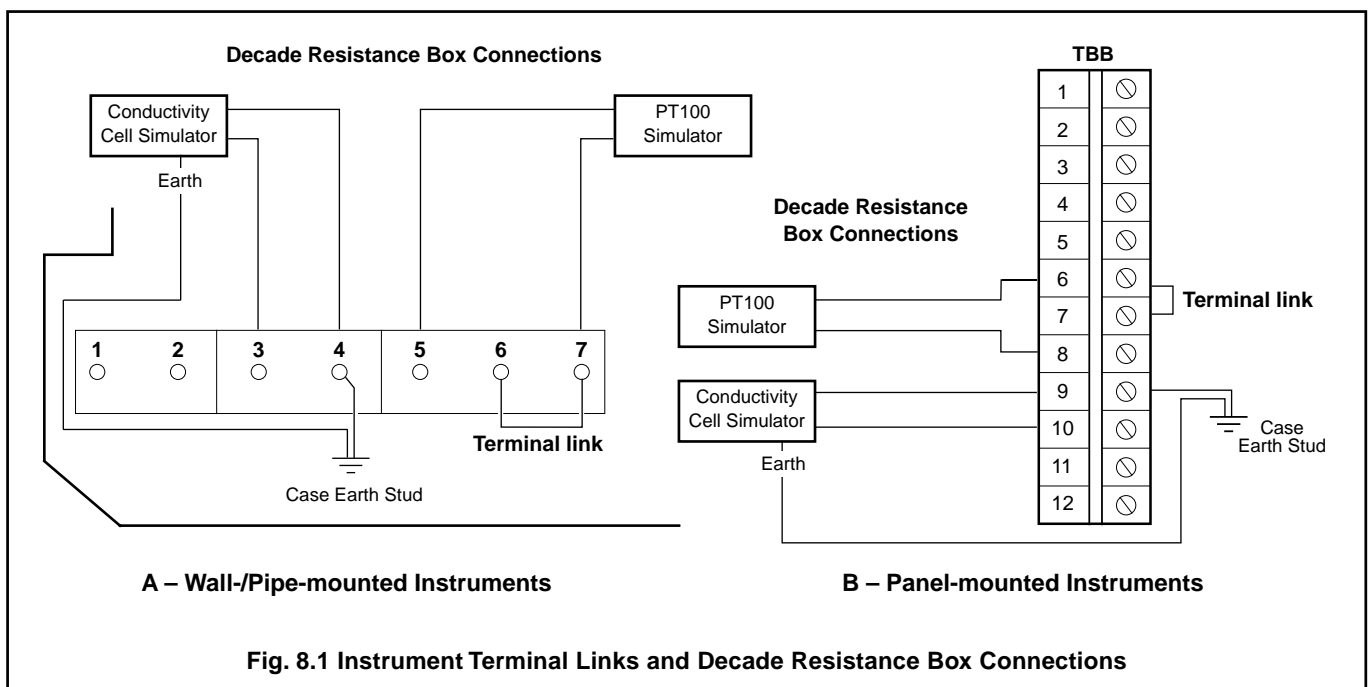

...8 CALIBRATION

8.3 Factory Settings Page

When carrying out the electrical calibration procedure, the actual values denoted by **x x x x x** are unimportant and are used only to determine display reading stability.

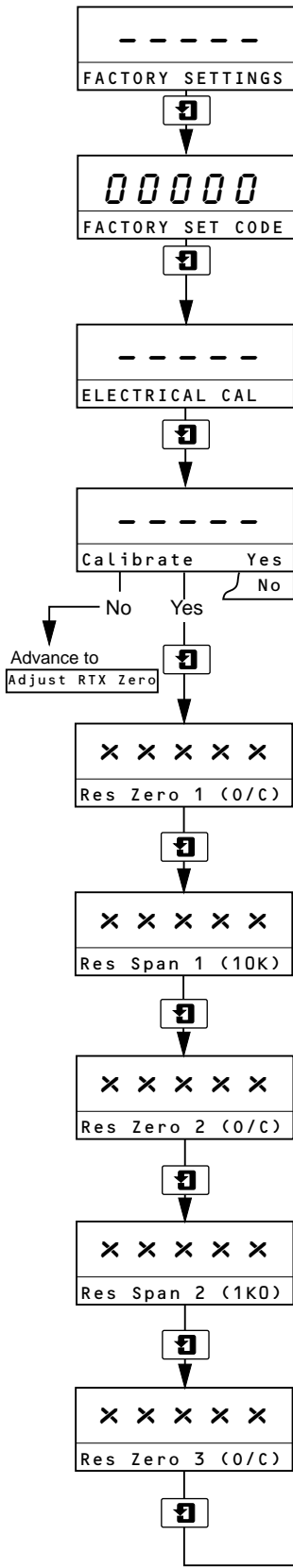

Factory Settings Access Code

Enter the required code number, between 00000 and 19999, to gain access to the factory settings. If an incorrect value is entered, access to subsequent parameters is prevented and the display reverts to the top of the **Factory Settings Page**.

Electrical Calibration

Select **Yes** to access the electrical calibration sequence. Select **No** to advance to **Adjust Retransmission 1 Zero**.



Caution. Do not select **Yes** unless instrument calibration is required.

Advance to next parameter.

Calibrate Cell Zero 1

Open circuit the cell simulator and allow the instrument display to stabilize.

Advance to next parameter.

Calibrate Cell Span 1

Set the cell simulator to 10k Ω and allow the instrument display to stabilize.

Advance to next parameter.

Calibrate Cell Zero 2

Open circuit the cell simulator and allow the instrument display to stabilize.

Advance to next parameter.

Calibrate Cell Span 2

Set the cell simulator to 1k Ω and allow the instrument display to stabilize.

Advance to next parameter.

Calibrate Cell Zero 3

Open circuit the cell simulator and allow the instrument display to stabilize.

Advance to next parameter.

Continued on next page.

...8.3 Factory Settings Page

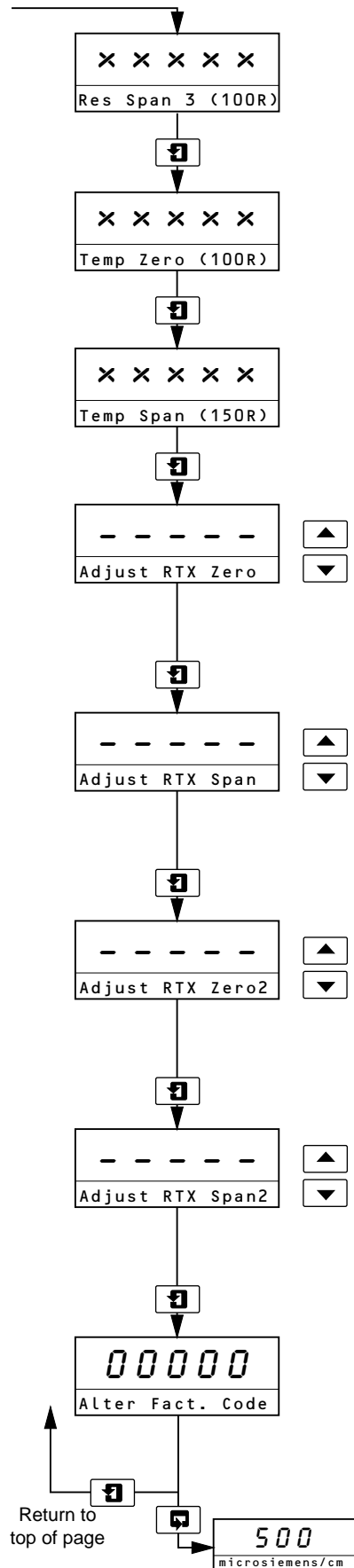

Calibrate Cell Span 3

Set the cell simulator to 100Ω and allow the instrument display to stabilize.

Advance to next parameter.

Calibrate Temperature Zero

Set the temperature simulator to 100Ω and allow the instrument display to stabilize.

Advance to next parameter.

Calibrate Temperature Span

Set the temperature simulator to 150Ω and allow the instrument display to stabilize.

Advance to next parameter.

Adjust Retransmission 1 Zero

Set the milliammeter reading to 4mA.

Note. The retransmission range selected in the **Set Up Retransmission Page** does not affect the reading.

Advance to next parameter.

Adjust Retransmission 1 Span

Set the milliammeter reading to 20mA.

Note. The retransmission range selected in the **Set Up Retransmission Page** does not affect the reading.

Advance to next parameter.

Adjust Retransmission 2 Zero (available only on 4620/800 and 4625/800 instruments)

Set the milliammeter reading to 4mA.

Note. The retransmission range selected in the **Set Up Retransmission Page** does not affect the reading.

Advance to next parameter.

Adjust Retransmission 2 Span (available only on 4620/800 and 4625/800 instruments)

Set the milliammeter reading to 20mA.

Note. The retransmission range selected in the **Set Up Retransmission Page** does not affect the reading.

Advance to next parameter.

Alter Factory Code

Set the factory settings access code to a value between 00000 and 19999.

Return to **Operating Page**.

9 SIMPLE FAULT FINDING

9.1 Error Messages

If erroneous or unexpected results are obtained the fault may be indicated by an error message – see Table 9.1. However some faults may cause problems with instrument calibration or give discrepancies when compared with independent laboratory measurements.

Error Message	Possible Cause
FAULTY PT100	Temperature compensator/associated connections are either open/short circuit.
FAULTY MODULE	The conductivity input module may be faulty.
NV MEMORY ERROR	The contents of the non-volatile memory has not been read correctly during power up.*

* To rectify the fault, switch off, wait 10 seconds and switch on again. If the fault persists contact the Company.

Table 9.1 Error Messages

9.2 No Response to Conductivity Changes

The majority of problems are associated with the conductivity cell, which must be cleaned as an initial check. It is also important that all program parameters have been set correctly and have not been altered inadvertently – see Section 7.

If the above checks do not resolve the fault:

- a) Check that the instrument responds to a resistance input. Disconnect the conductivity cell cable and connect a suitable resistance box directly to the transmitter input – see Section 4.3 or 4.4. Select the **Set Up Parameters Page** and set **Temperature Compensation** to **No** – see page 20. Check that the transmitter displays the correct values as set on the resistance box – see Table 9.2 or use the expression:

$$R = \frac{K \times 10^6}{G}$$

Where: R = resistance
K = cell constant
G = conductivity

Conductivity μS/cm (G)	Cell Constant (K)		
	0.05	0.1	1.0
	Resistance (R)		
0.055	909.091kΩ	–	–
0.1	500kΩ	1MΩ	–
0.5	100kΩ	200kΩ	–
1	50kΩ	100kΩ	1MΩ
5	10kΩ	20kΩ	200kΩ
10	5kΩ	10kΩ	100kΩ
50	1kΩ	2kΩ	20kΩ
100	500Ω	1kΩ	10kΩ
500	100Ω	200Ω	2kΩ
1000	–	100Ω	1kΩ
5000	–	–	200Ω
10000	–	–	100Ω

Table 9.2 Conductivity Readings for Resistance Inputs

Failure to respond to the input indicates a fault with the transmitter which must be returned to the Company for repair. Correct response, but with incorrect readings, usually indicates an electrical calibration problem. Re-calibrate the transmitter as detailed in Section 8.3.

- b) If the response in a) is correct, reconnect the conductivity cell cable and connect the resistance box to the cell end. Check that the transmitter displays the correct values as set on the resistance box in this configuration.

If the instrument passes check a) but fails check b), check the cable connections and condition. If the response for both checks is correct, replace the conductivity cell.

9.3 Checking the Temperature Input

Check that the instrument responds to a temperature input. Disconnect the PT100 leads and connect a suitable resistance box directly to the transmitter inputs – see Section 4.3 or 4.4. Check that the transmitter displays the correct values as set on the resistance box – see Table 9.3.

Incorrect readings usually indicate an electrical calibration problem – re-calibrate the instrument as detailed in Section 8.3.

Temperature °C	Input Resistance (Ω)
0	100.00
10	103.90
20	107.79
25	109.73
30	111.67
40	115.54
50	119.40
60	123.24
70	127.07
80	130.89
90	134.70
100	138.50
130.5	150.00

Table 9.3 Temperature Readings for Resistance Inputs

10 SPECIFICATION

Display

Measured value:

5-digit, 7-segment back-lit I.c.d.

Information:

16-character, single line, dot matrix back-lit I.c.d.

Ranges:

Programmable 0 to 0.5 μ S/cm up to 10,000 μ S/cm (utilizing various cell constants).

Scaling:

μ S/cm, μ S/m, mS/cm, mS/m, M Ω -cm, TDS and p.p.m.

Accuracy:

$\pm 1\%$ f.s.d., ± 1 digit.

Linearity:

$\pm 0.2\%$ f.s.d.

Resolution:

$\pm 0.1\%$ f.s.d.

Temperature measuring range:

-10 to 110°C (14 to 230°F).

Temperature compensation:

-10 to 110°C (14 to 230°F) automatic.

Temperature coefficient:

Programmable 0 to 3.0%/°C (0 to 1.5%/°F).

Temperature sensor:

Pt100 resistance thermometer.

Reference temperature:

20°C (68°F) or 25°C (77°F) programmable.

Set Points and Relays

No. of set points:

Two.

Set point adjustment:

Programmable.

Set point hysteresis:

$\pm 1\%$ of f.s.d. (fixed).

Local set point annunciation:

Red I.e.d.

No. of relays:

two.

Relay contacts:

Single pole changeover

Rating:	250V a.c.	250V d.c. max.
	3A a.c.	3A d.c. max.

Loading:		
(non-inductive)	750VA	30W max.
(inductive)	75VA	3W max.

Insulation, contacts to earth:

2kV r.m.s.

Retransmission

No. of retransmission signals:

One, fully isolated – standard.

Two, fully isolated – optional.

Output current:

0 to 10, 0 to 20 or 4 to 20mA programmable.

Output Ranges:

Retransmission 1:

Zero – 0, fixed.

Span – 10 to 100% of the display range.

Retransmission 2 (optional):

Programmable for Conductivity or Temperature:

Conductivity – as per Retransmission 1.

Temperature – 10 to 150°C (14 to 302°F)

minimum span 20°C (36°F).

Accuracy:

$\pm 0.25\%$ f.s.d.

Resolution:

0.1% of f.s.d.

Max. load resistance:

750 Ω (20mA max.).

Serial communication:

RS422/RS485 (optional).

Power Supply

Voltage requirements:

115V nom. ± 15 V, 50/60Hz.

230V nom. ± 30 V, 50/60Hz

Power consumption:

< 10VA a.c.

Error due to power supply variation:

Less than 0.1% for +6% –20% variation from nominal supply voltage.

Insulation:

Mains to earth 2kV r.m.s.

Environmental Data

Operating temperature limits:

-20 to 55°C (-4 to 131°F).

Storage temperature limits:

-25 to 55°C (-13 to 131°F).

Operating humidity limits:

Up to 95% RH non-condensing.

Mechanical Data

Mounting:

Model 4620 wall mounting, Model 4625 panel mounting.

Protection:

Model 4620 IP66, Model 4625 IP66 (front only).

Overall dimensions:

Model 4620 – 160 x 250 x 68mm
(6.3 x 9.84 x 2.68in.) – see Fig. 3.3

Model 4625 – 96 x 96 x 191mm
(3.78 x 3.78 x 7.52in.) – see Fig. 3.5

Panel cut-out:

92^{+0.8}_{-0.0} x 92^{+0.8}_{-0.0} mm (3.62^{+0.03}_{-0.00} x 3.62^{+0.03}_{-0.00} in.)

Weight:

Model 4620 – 2kg (4 $\frac{1}{2}$ lb)

Model 4625 – 1.5kg (3 $\frac{1}{4}$ lb)

APPENDICES

A1 Automatic Temperature Compensation

The conductivities of electrolytic solutions are influenced considerably by temperature variations. Thus, when significant temperature fluctuations occur, it is general practice to correct automatically the measured, prevailing conductivity to the value that would apply if the solution temperature were 25°C, the internationally accepted standard.

Most commonplace, weak aqueous solutions have temperature coefficients of conductance of the order of 2% per °C (i.e. the conductivities of the solutions increase progressively by 2% per °C rise in temperature); at higher concentrations the coefficient tends to become less.

At low conductivity levels, approaching that of ultra-pure water, dissociation of the H₂O molecule takes place and it separates into the ions H⁺ and OH⁻. Since conduction occurs only in the presence of ions, there is a theoretical conductivity level for ultra-pure water which can be calculated mathematically. In practice, correlation between the calculated and actual measured conductivity of ultra-pure water is very good.

Fig. A1 shows the relationship between the theoretical conductivity for ultra-pure water and that of high purity water (ultra-pure water with a slight impurity), when plotted against temperature. The figure also illustrates how a small temperature variation considerably changes the conductivity. Subsequently, it is essential that this temperature effect is eliminated at conductivities approaching that of ultra-pure water, in order to ascertain whether a conductivity variation is due to a change in impurity level or in temperature.

For conductivity levels above 1µS/cm, the generally accepted expression relating conductivity and temperature is:

$$G_t = G_{25} [1 + \alpha (t - 25)]$$

Where: G_t = conductivity at the temperature $t^{\circ}\text{C}$

G_{25} = conductivity at the standard temperature (25°C)

α = temperature coefficient per °C

At conductivities between 1µS/cm and 1,000µS/cm, α lies generally between 0.015/°C and 0.025/°C. When making temperature compensated measurements, a conductivity instrument must carry out the following computation to obtain G_{25} :

$$G_{25} = \frac{G_t}{[1 + \alpha (t - 25)]}$$

However, for ultra-pure water conductivity measurement, this form of temperature compensation alone is unacceptable since considerable errors exist at temperatures other than 25°C.

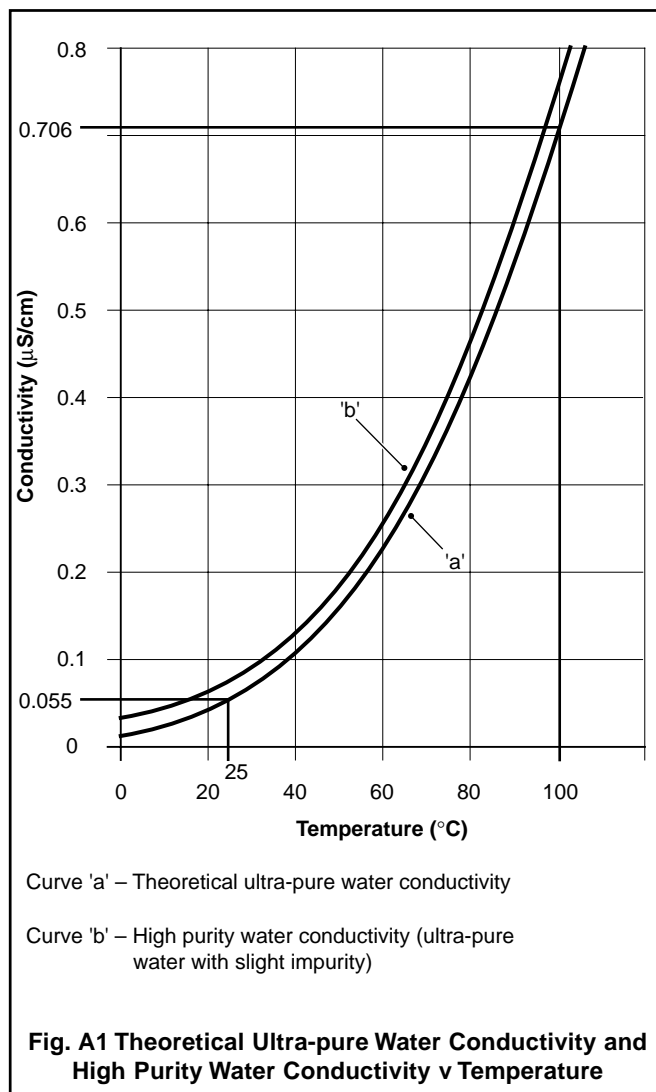

...A1 Automatic Temperature Compensation

At high purity water conductivity levels, the conductivity/temperature relationship is made up of two components: the first component, due to the impurities present, generally has a temperature coefficient of approximately 0.02/°C; and the second, which arises from the effect of the H⁺ and OH⁻ ions, becomes predominant as the ultra-pure water level is approached.

Consequently, to achieve full automatic temperature compensation, the above two components must be compensated for separately according to the following expression:

$$G_{25} = \frac{G_t - G_{upw}}{[1 + \infty (t - 25)]} + 0.055$$

Where: G_t = conductivity at temperature t°C

G_{upw} = ultra-pure water conductivity at temperature t°C

∞ = impurity temperature coefficient

0.055 = conductivity in $\mu\text{S}/\text{cm}$ of ultra-pure water at 25°C

The expression is simplified as follows:

$$G_{25} = \frac{G_{imp}}{[1 + \infty (t - 25)]} + 0.055$$

Where: G_{imp} = impurity conductivity at temperature t°C

The above expression was solved in earlier analog instrumentation by using two temperature sensing elements located in the conductivity measuring cell. However, models 4620 and 4625 now utilize the computational ability of a microprocessor to achieve ultra-pure water temperature compensation using only a single platinum resistance thermometer and mathematically calculating the temperature compensation required to give the correct conductivity at the reference temperature.

A1.1 Calculation of Temperature Coefficient

The temperature coefficient of a solution can be obtained experimentally by taking non-temperature compensated conductivity measurements at two temperatures and applying the following expression:

$$\infty = \frac{G_{t_2} - G_{t_1}}{G_{t_1} (t_2 - 25) - G_{t_2} (t_1 - 25)}$$

Where: G_{t_2} = conductivity measurement at a temperature of t₂°C

G_{t_1} = conductivity measurement at a temperature of t₁°C

One of these measurements could be made at the ambient temperature and the other obtained by heating the sample.

Temperature coefficient (%/°C) = $\infty \times 100$.

A2 Relationship Between Conductivity and Total Dissolved Solids (T.D.S.) Measurement

The T.D.S. factor (i.e. the relationship between conductivity ($\mu\text{S}/\text{cm}$) and T.D.S. in p.p.m.) is totally dependent on the properties of the solution being measured.

In simple solutions where only one electrolyte is present, the conductivity/T.D.S. ratio can easily be ascertained, e.g. 0.5 in the case of sodium chloride. However, in complex solutions where more than one electrolyte is present, the ratio is not easily calculated and can only be reliably determined by laboratory testing (e.g. precipitation and weighing). The ratio in these cases is found to vary between approximately 0.4 and 0.8, depending on the chemical constituents, and is constant only when the chemical ratios remain constant throughout a particular process.

In cases where the T.D.S. factor cannot be determined easily, refer to the supplier of the particular chemical treatment being used.

A3 Insertion and Removal of Withdrawable Conductivity Cells

A3.1 Insertion – Fig. A2

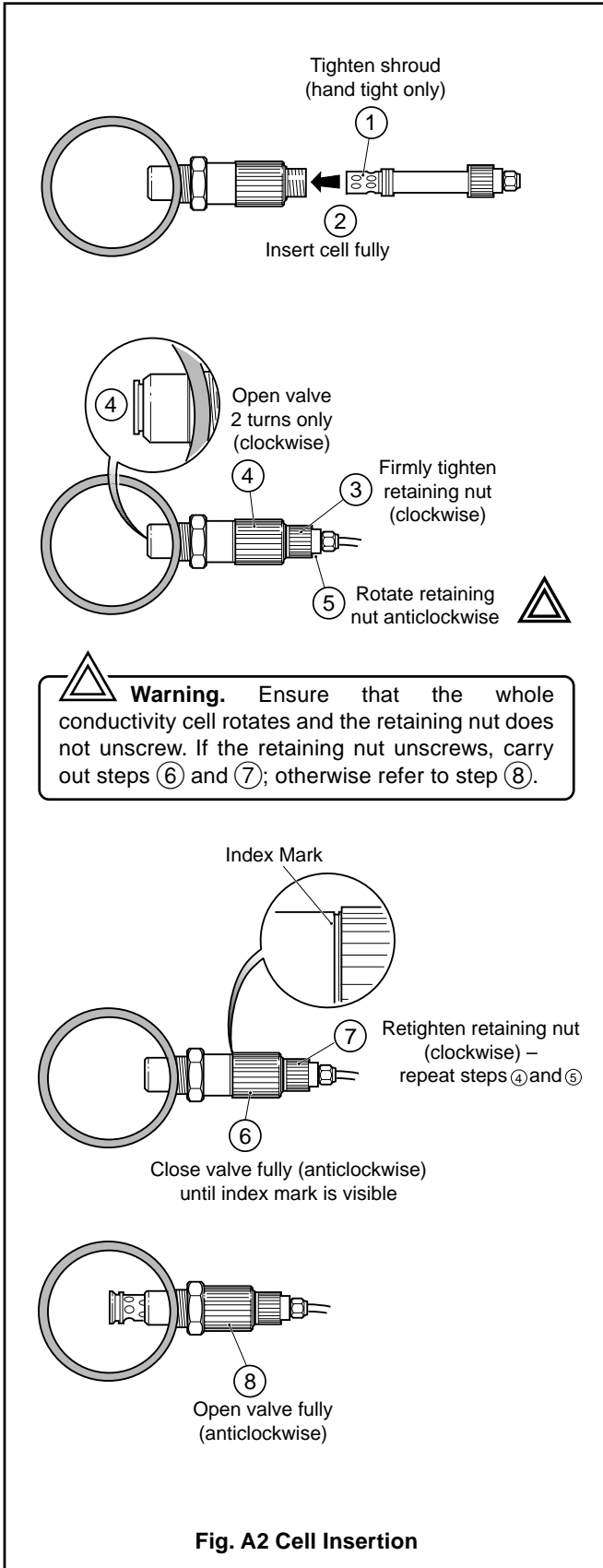

A3.2 Removal – Fig. A3

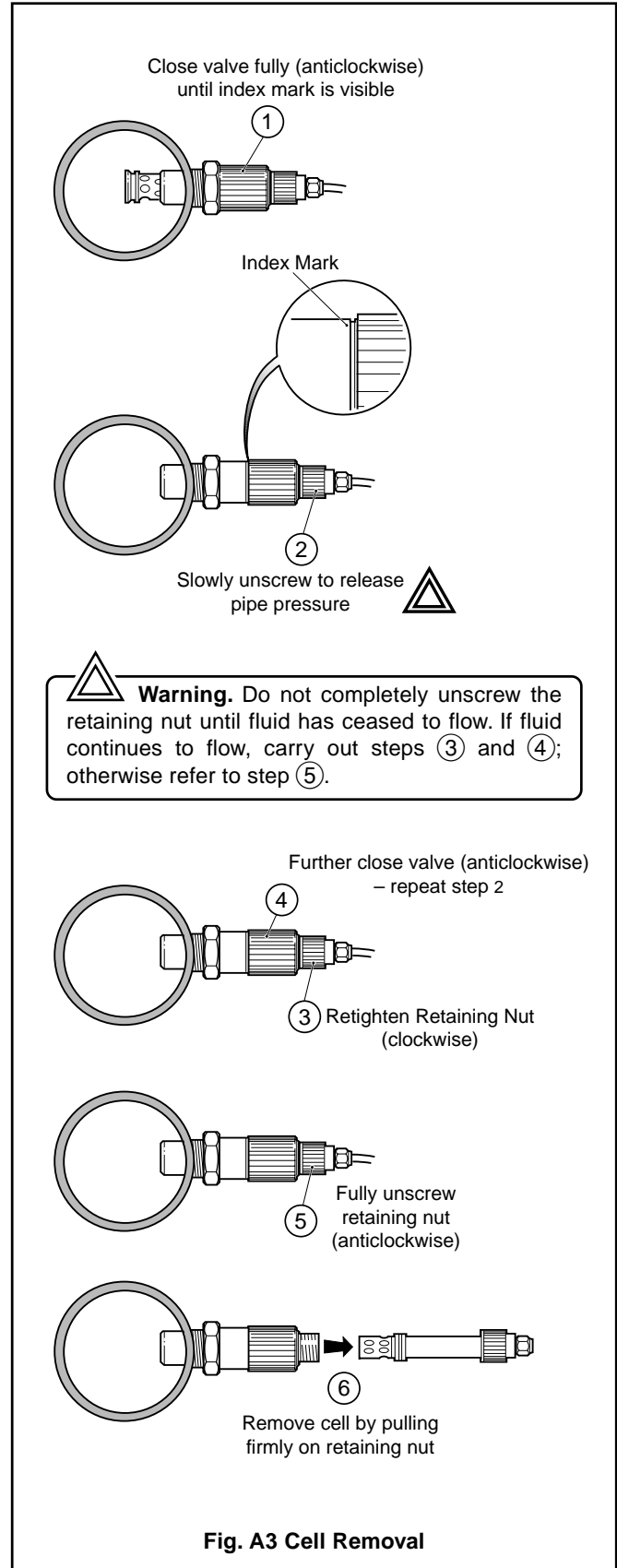

PRODUCTS & CUSTOMER SUPPORT

Products

Automation Systems

- *for the following industries:*
 - Chemical & Pharmaceutical
 - Food & Beverage
 - Manufacturing
 - Metals and Minerals
 - Oil, Gas & Petrochemical
 - Pulp and Paper

Drives and Motors

- *AC and DC Drives, AC and DC Machines, AC motors to 1kV*
- *Drive systems*
- *Force Measurement*
- *Servo Drives*

Controllers & Recorders

- *Single and Multi-loop Controllers*
- *Circular Chart , Strip Chart and Paperless Recorders*
- *Paperless Recorders*
- *Process Indicators*

Flexible Automation

- *Industrial Robots and Robot Systems*

Flow Measurement

- *Electromagnetic Magnetic Flowmeters*
- *Mass Flow Meters*
- *Turbine Flowmeters*
- *Wedge Flow Elements*

Marine Systems & Turbochargers

- *Electrical Systems*
- *Marine Equipment*
- *Offshore Retrofit and Refferbishment*

Process Analytics

- *Process Gas Analysis*
- *Systems Integration*

Transmitters

- *Pressure*
- *Temperature*
- *Level*
- *Interface Modules*

Valves, Actuators and Positioners

- *Control Valves*
- *Actuators*
- *Positioners*

Water, Gas & Industrial Analytics Instrumentation

- *pH, conductivity, and dissolved oxygen transmitters and sensors*
- *ammonia, nitrate, phosphate, silica, sodium, chloride, fluoride, dissolved oxygen and hydrazine analyzers.*
- *Zirconia oxygen analyzers, katharometers, hydrogen purity and purge-gas monitors, thermal conductivity.*

Customer Support

We provide a comprehensive after sales service via a Worldwide Service Organization. Contact one of the following offices for details on your nearest Service and Repair Centre.

United Kingdom

ABB Limited
Tel: +44 (0)1453-826-661
Fax: +44 (0)1453-827-856

United States of America

ABB Inc.
Tel: +1 775 883 4366
Fax: +1 775 883 4366

Client Warranty

Prior to installation, the equipment referred to in this manual must be stored in a clean, dry environment, in accordance with the Company's published specification. Periodic checks must be made on the equipment's condition.

In the event of a failure under warranty, the following documentation must be provided as substantiation:

1. A listing evidencing process operation and alarm logs at time of failure.
2. Copies of operating and maintenance records relating to the alleged faulty unit.

ABB has Sales & Customer Support
expertise in over 100 countries worldwide

www.abb.com

The Company's policy is one of continuous product
improvement and the right is reserved to modify the
information contained herein without notice.

Printed in UK (07.03)

© ABB 2003



ABB Limited

Oldends Lane Stonehouse
Gloucestershire
GL10 3TA

UK

Tel: +44 (0)1483 826 661

Fax: +44 (0)1483 827 856

ABB Inc.

2175 Lockheed Way
Carson City
NV 89706

USA

Tel: +1 775 883 4366

Fax: +1 775 883 4376