



## The Company

We are an established world force in the design and manufacture of instrumentation for industrial process control, flow measurement, gas and liquid analysis and environmental applications.

As a part of ABB, a world leader in process automation technology, we offer customers application expertise, service and support worldwide.

We are committed to teamwork, high quality manufacturing, advanced technology and unrivalled service and support.

The quality, accuracy and performance of the Company's products result from over 100 years experience, combined with a continuous program of innovative design and development to incorporate the latest technology.

The UKAS Calibration Laboratory (No. 0255) is just one of ten flow calibration plants operated by the Company, and is indicative of our dedication to quality and accuracy.

EN ISO 9001:2000



Cert. No. Q 05907

EN 29001 (ISO 9001)



Lenno, Italy – Cert. No. 9/90A

## Electrical Safety

This equipment complies with the requirements of CEI/IEC 61010-1:1993 "Safety requirements for electrical equipment for measurement, control, and laboratory use". If the equipment is used in a manner NOT specified by the Company, the protection provided by the equipment may be impaired.

## Symbols

One or more of the following symbols may appear on the equipment labelling:

	<b>Warning</b> – Refer to the manual for instructions		Direct current supply only
	<b>Caution</b> – Risk of electric shock		Alternating current supply only
	Protective earth (ground) terminal		Both direct and alternating current supply
	Earth (ground) terminal		The equipment is protected through double insulation

Information in this manual is intended only to assist our customers in the efficient operation of our equipment. Use of this manual for any other purpose is specifically prohibited and its contents are not to be reproduced in full or part without prior approval of the Technical Publications Department.

### Health and Safety

To ensure that our products are safe and without risk to health, the following points must be noted:

1. The relevant sections of these instructions must be read carefully before proceeding.
2. Warning labels on containers and packages must be observed.
3. Installation, operation, maintenance and servicing must only be carried out by suitably trained personnel and in accordance with the information given.
4. Normal safety precautions must be taken to avoid the possibility of an accident occurring when operating in conditions of high pressure and/or temperature.
5. Chemicals must be stored away from heat, protected from temperature extremes and powders kept dry. Normal safe handling procedures must be used.
6. When disposing of chemicals ensure that no two chemicals are mixed.

Safety advice concerning the use of the equipment described in this manual or any relevant hazard data sheets (where applicable) may be obtained from the Company address on the back cover, together with servicing and spares information.

---

# CONTENTS

---

<b>Contents</b>	<b>Page</b>
1 Preparation .....	2
1.1 Unpacking .....	2
<b>2 INSTALLATION .....</b>	<b>2</b>
2.1 Adapting the MagMaster Transmitter .....	2
2.2 Preparing the Transmitter for Verification .....	3
2.2.1 Removing the Covers .....	3
2.2.2 Fitting the Adaptor Board .....	4
2.2.3 Wiring the Adaptor Plug ..	5
2.2.4 System Setup .....	5
<b>3 OPERATION .....</b>	<b>6</b>
3.1 Software Installation .....	6
3.1.1 Windows 3.1 or 3.11 .....	6
3.1.2 Windows 95 .....	6
3.2 Initialising the CalMaster .....	6
3.3 Battery Charging .....	7

---

## 1 PREPARATION

---

### 1.1 Unpacking

Unpack and visually inspect the CalMaster.

Also packed with the CalMaster are:

- a) CalMaster sensor test lead set.
- b) CalMaster to MagMaster communication lead set (includes three test probes for frequency measurement).
- c) Adaptor PCBs incorporating a plug to accept the socket in item d) below.
- d) Socket which fits into item c) above. The socket is first terminated with the sensor cable.
- e) One lead to interconnect the CalMaster and a computer (Serial Data Connection).
- f) Screwdriver for terminals.
- g) Two 'CalMaster Software' Disks.
- h) This Instruction Manual.
- i) Mains operated battery charger
- j) Lead for charging battery from 12 Volts.

Save packing materials for any re-shipment, or to support any claim of shipment damage. All damage claims are made against the carrier and are the responsibility of the customer.

---

## 2 INSTALLATION

---

### 2.1 Adapting the MagMaster Transmitter

To enable a MagMaster system to be tested by the CalMaster it is necessary to initially fit a small adaptor board to the MagMaster transmitter. This adaptor is provided with the CalMaster Unit.

Once the adaptor is fitted to the MagMaster transmitter, the CalMaster can be easily connected to the transmitter for testing at any time.

Extra adaptor kits are available from the Company

The adaptor is supplied in the form of a PCB fitted with connectors which fit into the sensor connection terminals of the MagMaster transmitter.

A connection socket is also provided, which after termination with the sensor cable, is connected with the plug on the adaptor PCB. This provides a flexible means of inserting connecting leads from the CalMaster, when testing is required, and reconnecting the MagMaster sensor wiring when the testing is complete.

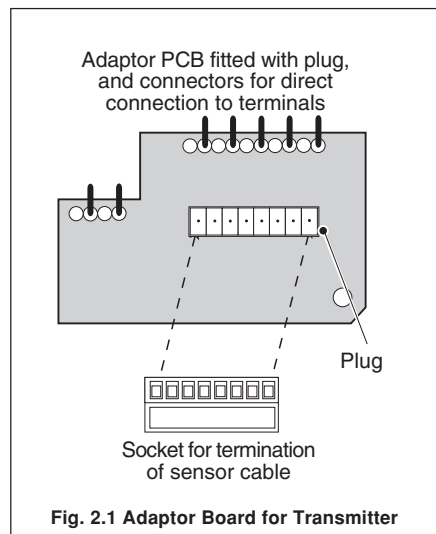

2.2 Preparing the MagMaster Transmitter for Verification

2.2.1 Removing the Covers

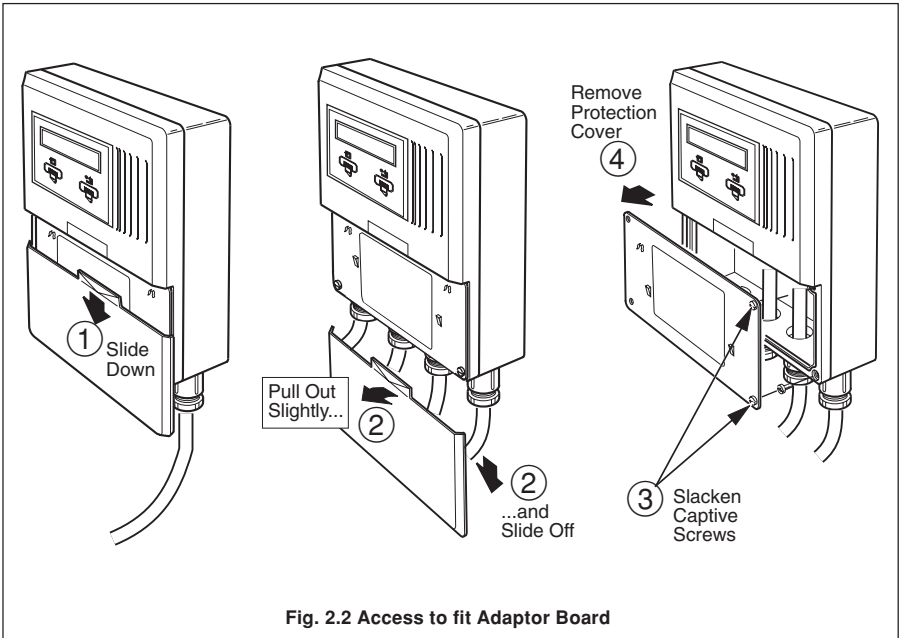

## ...2 INSTALLATION

### 2.2.2 Fitting the Adaptor Board (Fig. 2.3 and 2.4)

- Turn off the power to the MagMaster.
- Record the position of the sensor cable wiring and remove the wiring from the terminals. Slacken the terminal screws by at least 6 turns.
- Carefully ease the sensor wiring to one side and arrange the adaptor board so that the extended pins fit into the terminals previously occupied by the sensor wiring – see Fig.2.4.
- Fit and tighten the securing screw to the corner of the adaptor board.
- Tighten the associated terminal block screws.

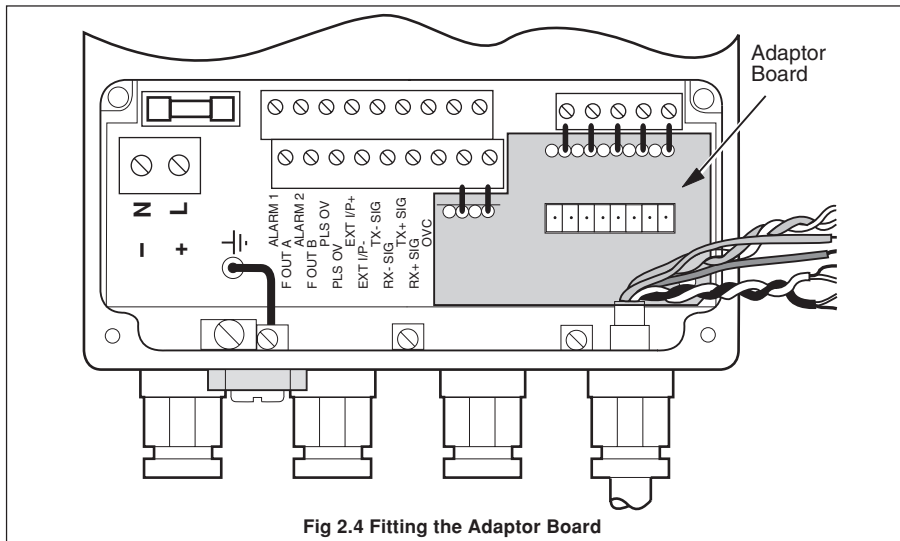
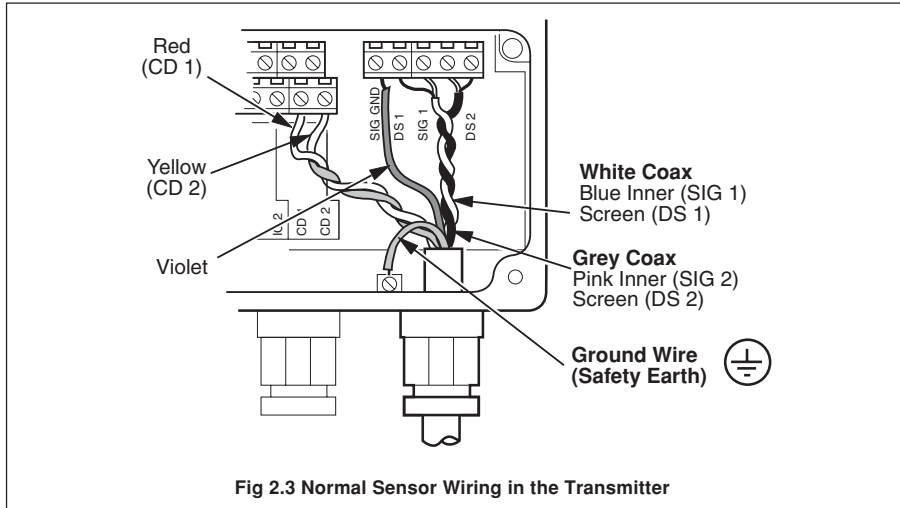

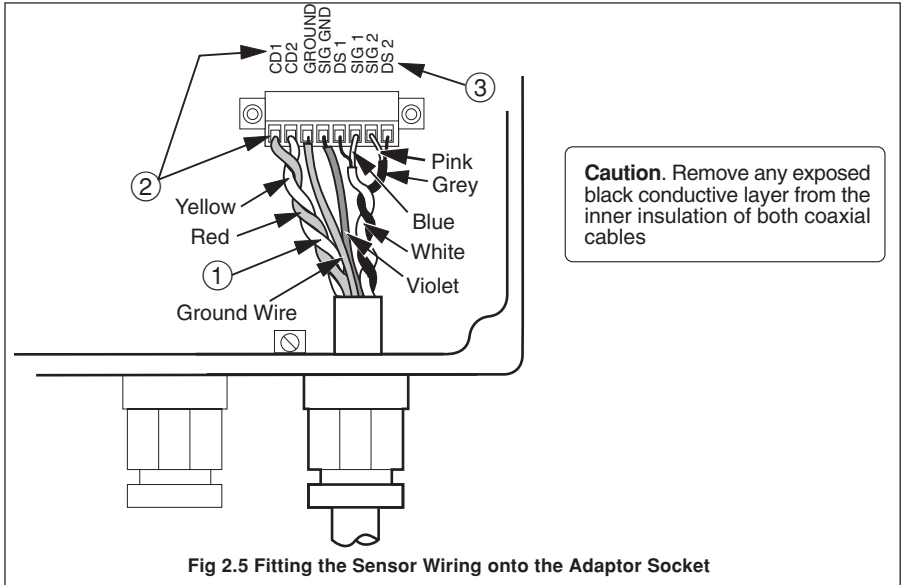

Fig 2.5 Fitting the Sensor Wiring onto the Adaptor Socket

### 2.2.3 Wiring the Adaptor Socket (Fig. 2.5)

The wires in the sensor cable must now be wired to the 8-way adaptor socket which will then connect to the plug on the adaptor board.

- ① Adjust the wire lengths of the sensor cable to allow for termination and subsequent removal of the adaptor socket.
- ② Insert the sensor cable wiring into the socket as shown in Fig 2.5, and tighten the plug screws with the screwdriver provided.

**Caution.** Ensure that no bare wires touch each other; in particular, ensure that there is no connection between the screens of the grey and white coaxial wires.

- ③ Insert the adaptor socket into the plug on the adaptor PCB.

**Warning.** Testing the MagMaster involves operation with the MagMaster terminal cover removed, exposing live terminals. Take precautions to avoid electric shock hazard.

Switch on the power to the MagMaster and check that the system operates correctly.

If the MagMaster operates correctly, either the transmitter covers can be replaced for normal working or the MagMaster can be tested by the CalMaster.

### 2.2.4 System Setup (Fig. 2.6)

**Warning.** Care is needed when CalMaster is used with cathodically protected MagMasters.

Cathodically protected installations, wired as directed in the MagMaster manual, which isolate the sensor using earthing flanges, are electrically earthed and do not pose any safety issues.

When apparatus, such as CalMaster or the PC, are connected to systems which 'float' the sensor at the cathodic potential, this apparatus will also float at the cathodic potential and therefore must not be grounded or accidentally grounded.

With the adaptor PCB installed in the MagMaster Transmitter as detailed in Section 2.2.2, and the sensor cable plugged into the adaptor as for normal operation:

- a) Connect lead 3 of the CalMaster to the MagMaster 9-pin D-Type socket. The three small probes should not be connected until requested to do so by the CalMaster software. For details of when to connect these probe leads, follow the instructions on the provided software – see Section 3.2. For details of where to connect the probe leads, follow the 'on-line help' under the heading, 'test lead connections'.
- b) Connect the 9-Pin D-Type socket on the CalMaster to a computer (Serial Comms Connection).

**Note.** The use of CalMaster with a line powered desktop PC, as opposed to a portable, battery powered PC, is not recommended, as the resulting ground (earth) loop can corrupt the sensitive CalMaster measurements.

In these circumstances, an external RS232 isolator between the PC and the CalMaster will effect a solution

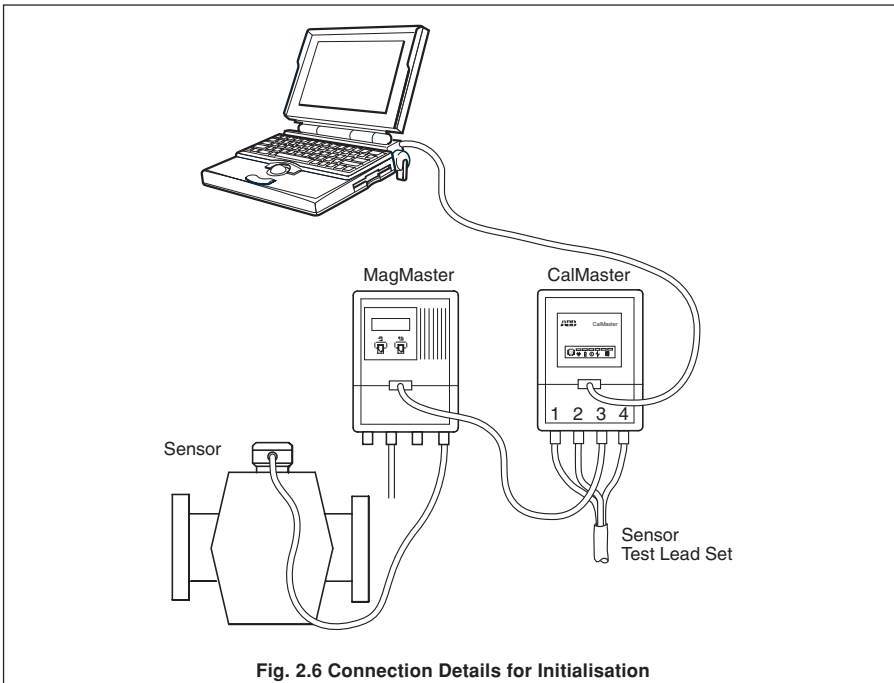

Fig. 2.6 Connection Details for Initialisation

### 3.1 Software Installation

**Note.** The CalMaster Program can be used with or without a 'Mouse'. Where instructions say 'Select', either click on the item with the left hand mouse button, or use the 'TAB' key to move between fields and press the 'ENTER' key to complete the selection.

Insert the first CalMaster floppy disk into the computer disk drive and proceed as follows:

#### 3.1.1 Windows 3.1 or 3.11

- a) Select 'RUN' from the Program or File Manager menu.
- b) Type 'a:setup' or 'b:setup', depending on the floppy drive designation.
- c) Press 'ENTER' and follow instructions.

#### 3.1.2 Windows 95

- a) Press 'START'
- b) Select 'Settings', 'Control Panel' and double click on 'Add/Remove Programs'.
- c) Choose 'Install' and follow the instructions.

### 3.2 Initialising the CalMaster

**Note.** It is advisable to avoid the use of radio equipment in the vicinity of a CalMaster/MagMaster test setup, during testing.

- a) From Windows '**Program Manager**' open the '**ABB Applications**' folder and double click on the '**CalMaster**' icon. The program automatically finds the MagMaster and opens up to the Main 'ABB' Screen.
- d) Select '**Test Meter**', and the 'Verification Information' screen is displayed.
- c) Follow the on-screen instructions and on-screen Help as required – click on the Help button or press F1.

### 3.3 Battery Charging

The CalMaster internal battery may be charged using the mains charger unit supplied, or from a 12 volt vehicle connector for which a lead is also supplied.

Charging is automatic and takes approximately 4 hours for a discharged battery.

For further information, refer to **<battery monitoring>** from the CalMaster **<options>** menu.

---

## NOTES

---

# PRODUCTS & CUSTOMER SUPPORT

## Products

### Automation Systems

- **for the following industries:**
  - Chemical & Pharmaceutical
  - Food & Beverage
  - Manufacturing
  - Metals and Minerals
  - Oil, Gas & Petrochemical
  - Pulp and Paper

### Drives and Motors

- **AC and DC Drives, AC and DC Machines, AC motors to 1kV**
- **Drive systems**
- **Force Measurement**
- **Servo Drives**

### Controllers & Recorders

- **Single and Multi-loop Controllers**
- **Circular Chart , Strip Chart and Paperless Recorders**
- **Paperless Recorders**
- **Process Indicators**

### Flexible Automation

- **Industrial Robots and Robot Systems**

### Flow Measurement

- **Electromagnetic Magnetic Flowmeters**
- **Mass Flow Meters**
- **Turbine Flowmeters**
- **Wedge Flow Elements**

### Marine Systems & Turbochargers

- **Electrical Systems**
- **Marine Equipment**
- **Offshore Retrofit and Refurbishment**

### Process Analytics

- **Process Gas Analysis**
- **Systems Integration**

### Transmitters

- **Pressure**
- **Temperature**
- **Level**
- **Interface Modules**

### Valves, Actuators and Positioners

- **Control Valves**
- **Actuators**
- **Positioners**

### Water, Gas & Industrial Analytics

#### Instrumentation

- **pH, conductivity, and dissolved oxygen transmitters and sensors**
- **ammonia, nitrate, phosphate, silica, sodium, chloride, fluoride, dissolved oxygen and hydrazine analyzers.**
- **Zirconia oxygen analyzers, katharometers, hydrogen purity and purge-gas monitors, thermal conductivity.**

## Customer Support

We provide a comprehensive after sales service via our Worldwide Service Organization. Contact one of the following offices for details on your nearest Service and Repair Centre.

### United Kingdom

ABB Limited  
Tel: +44 (0)1453 826661  
Fax: +44 (0)1453 829671

### United States of America

ABB Inc.  
Tel: +1 215 674 6000  
Fax: +1 215 674 7183

#### Client Warranty

Prior to installation, the equipment referred to in this manual must be stored in a clean, dry environment, in accordance with the Company's published specification.

Periodic checks must be made on the equipment's condition. In the event of a failure under warranty, the following documentation must be provided as substantiation:

1. A listing evidencing process operation and alarm logs at time of failure.
2. Copies of all storage, installation, operating and maintenance records relating to the alleged faulty unit.

---

ABB has Sales & Customer Support expertise in over 100 countries worldwide

[www.abb.com](http://www.abb.com)

The Company's policy is one of continuous product improvement and the right is reserved to modify the information contained herein without notice.

Printed in UK (08.09)

© ABB 2009



**ABB Limited**  
Oldends Lane, Stonehouse  
Gloucestershire  
GL10 3TA  
UK  
Tel: +44 (0)1453 826661  
Fax: +44 (0)1453 829671

**ABB Inc.**  
125 E. County Line Road  
Warminster  
PA 18974  
USA  
Tel: +1 215 674 6000  
Fax: +1 215 674 7183