

2600T Series Pressure Transmitters

Model 264HP Gauge
Model 264NP Absolute
with pulp and paper direct mount seal



- **Base accuracy : $\pm 0.075\%$**
- **Reliable sensing system coupled with very latest digital technologies**
- **Span limits**
 - 1.1 to 16000kPa; 4.35inH₂O to 2320psi
- **Comprehensive sensor choice**
 - optimize in-use total performance and stability
- **5-year stability**
- **Flexible configuration facilities**
 - provided locally via local keys combined with LCD indicator or via hand held terminal or PC configuration platform
- **Multiple protocol availability**
 - provides integration with HART®, PROFIBUS PA and FOUNDATION Fieldbus platforms offering interchangeability and transmitter upgrade capabilities
- **Application specific process interfaces complete of process spud**
- **PED compliance to sound engineering practice (SEP)**



**ABB 2600T Series
Engineered solutions
for all applications**

General Description

Models 264HP/NP detailed in this data sheet integrate a direct mount seal on the positive side, having the negative side reference at atmospheric or vacuum pressure, respectively for gauge or absolute measurements.

The integral seal is available in 1in and 1 1/2in diaphragm size specifically designed for pulp and paper industry applications, providing a flush diaphragm to the process; this solution ensures the measure reliability avoiding all problems of crystallization/polymerization, typical of pulps having viscosity as in the paper mill.

Functional Specifications

Range and span limits

Sensor Code	Upper Range Limit (URL)	Lower Range Limit (LRL) for 264HP	Minimum span
G	65kPa 650mbar 260inH ₂ O	-65kPa -650mbar -260inH ₂ O	1.1kPa 11mbar 4.35inH ₂ O
H	160kPa 1600mbar 642inH ₂ O	0.07kPa abs 0.7mbar abs 0.5mmHg	2.67kPa (§) 26.7mbar (§) 10.7inH ₂ O (§)
M	600kPa 6bar 87psi	0.07kPa abs 0.7mbar abs 0.5mmHg	10kPa 0.1bar 1.45psi
P	2400kPa 24bar 348psi	0.07kPa abs 0.7mbar abs 0.5mmHg	40kPa 0.4bar 5.8psi
Q	8000kPa 80bar 1160psi	0.07kPa abs 0.7mbar abs 0.5mmHg	134kPa 1.34bar 19.4psi
S	16000kPa 160bar 2320psi	0.07kPa abs 0.7mbar abs 0.5mmHg	267kPa 2.67bar 38.7psi

Lower Range Limit (LRL) for 264NP is 0.07kPa abs, 0.7mbar abs, 0.5mmHg for all ranges

(§) Minimum span for sensor code H with 1in seal is 8kPa, 80mbar, 32.1inH₂O

SENSOR CODE G IS NOT AVAILABLE WITH 1in PULP&PAPER SEAL

Span limits

Maximum span = URL

IT IS RECOMMENDED TO SELECT THE TRANSMITTER SENSOR CODE PROVIDING THE TURNDOWN VALUE AS LOWEST AS POSSIBLE TO OPTIMIZE PERFORMANCE CHARACTERISTICS.

Zero suppression and elevation

Zero and span can be adjusted to any value within the range limits detailed in the table as long as:

- calibrated span ≥ minimum span

Damping

Selectable time constant : 0, 0.25, 0.5, 1, 2, 4, 8 or 16s.
This is in addition to sensor response time

Turn on time

Operation within specification in less than 1s with minimum damping.

Insulation resistance

> 100MΩ at 1000VDC (terminals to earth)

Operative limits

Temperature limits °C (°F) :

Ambient (is the operating temperature)

Silicone oil DC200 filling: -40°C and +85°C (-40°F and +185°F)

Lower ambient limit for LCD indicators: -20°C (-4°F)

Upper ambient limit for LCD indicators: +70°C (+158°F)

Note : For Hazardous Atmosphere applications see the temperature range specified on the certificate/approval relevant to the aimed type of protection

Process

The following table show characteristics of fill fluids when used in transmitters with pulp and paper direct mount seal on high pressure side.

FILL FLUIDS (APPLICATION)	OPERATING CONDITIONS			
	Tmax @ Pabs>of	Pmin mbar abs (psia)	Tmax @ P min	Tmin
Silicone oil-DC200 (General purpose)	150 (302) @ 0.7mbar	0.7 (0.01)	150 (302)	-40 (-40)
Mineral oil-MARCOL 82 (Food-Sanitary) FDA	150 (302) @ 110mbar	33 (0.5)	40 (104)	-40 (-40)

Storage

Lower limit: -50°C (-58°F); -40°C (-40°F) for LCD indicators

Upper limit: +85°C (+185°F)

Pressure limits

Overpressure limits (without damage to the transmitter)

0.07kPa abs, 0.7mbar abs, 0.01psia to transmitter sensor limit or rating of seal/fitting, whichever is less:

- 3MPa, 30bar, 435psi for 1in seal - sealing with gaskets
- 5MPa, 50bar, 725psi for 1 1/2in seals - sealing with gasket
- 4MPa, 40bar, 580psi for 1in seal with ball valve connection
- 21MPa, 210bar, 3045psi for seals with male threaded connection (1in NPT, 1 1/2in NPT, G 1in A and G 1 1/2in A).

Models 264HP and 264NP transmitters can withstand an overpressure of:

- 14MPa, 140bar, 2030psi for sensor codes G, H, M
- 21MPa, 210bar, 3045psi for sensor codes P, Q, S.

Proof pressure

The transmitter can be exposed without leaking to line pressure of up to:

- 28MPa, 280bar, 4060psi for sensor codes G, H, M of models 264HP and 264NP
- 40MPa, 400bar, 5800psi for sensor codes P, Q, S of models 264HP and 264NP

or two times the rating of seal/fitting whichever is less.

Meet ANSI/ISA-S 82.03 hydrostatic test requirements and SAMA PMC 27.1.

Environmental limits

Electromagnetic compatibility (EMC)

Comply with EN 61000-6-3 for emission and EN 61000-6-2 for immunity requirements and test;

Radiated electromagnetic immunity level: (according to IEC 1000-4-3, EN61000-4-3)	30V/m
Conducted electromagnetic immunity level: (according to IEC 1000-4-6, EN 61000-4-6)	30V
Surge immunity level (with surge protector): (according to IEC 1000-4-5 EN 61000-4-5)	4kV
Fast transient (Burst) immunity level: (according to IEC 1000-4-4 EN 61000-4-4)	4kV

Pressure equipment directive (PED)

Comply with 97/23/EEC following sound engineering practice (SEP)

Humidity

Relative humidity:	up to 100% annual average
Condensing, icing:	admissible

Vibration resistance

Accelerations up to 2g at frequency up to 1000Hz
(according to IEC 60068-2-6)

Shock resistance (according to IEC 60068-2-27)

Acceleration:	50g
Duration:	11ms

Wet and dust-laden atmospheres

The transmitter is dust and sand tight and protected against immersion effects as defined by EN 60529 (1989) to IP 67 (IP 68 on request) or by NEMA to 4X or by JIS to C0920. IP65 with Harting Han connector.

Hazardous atmospheres

With or without output meter/integral display

- COMBINED ATEX (Intrinsic safety and flameproof), FM and CSA ZELM approval. See below detailed classifications.
- COMBINED INTRINSIC SAFETY and FLAMEPROOF/EUROPE: ATEX/ZELM approval
 - II 1 GD T50°C, EEx ia IIC T6 (-40°C ≤ Ta ≤ +40°C)
 - T95°C, EEx ia IIC T4 (-40°C ≤ Ta ≤ +85°C)
 - II 1/2 GD T85°C, EEx d IIC T6 (-40°C ≤ Ta ≤ +75°C)
- INTRINSIC SAFETY/EUROPE: ATEX/ZELM approval
 - II 1 GD T50°C, EEx ia IIC T6 (-40°C ≤ Ta ≤ +40°C)
 - T95°C, EEx ia IIC T4 (-40°C ≤ Ta ≤ +85°C)
- TYPE "N"/EUROPE: ATEX/ZELM type examination (for HART)
 - II 3 GD T50°C, EEx nL IIC T6 (-40°C ≤ Ta ≤ +40°C)
 - T95°C, EEx nL IIC T4 (-40°C ≤ Ta ≤ +85°C)
- FLAMEPROOF/EUROPE: ATEX/CESI approval
 - II 1/2 GD T85°C, EEx d IIC T6 (-40°C ≤ Ta ≤ +75°C)
- CANADIAN STANDARDS ASSOCIATION and FACTORY MUTUAL:
 - Explosionproof: Class I, Div. 1, Groups A, B, C, D
 - Dust ignitionproof: Class II, Div. 1, Groups E, F, G
 - Suitable for: Class II, Div. 2, Groups F, G; Class III, Div. 1, 2
 - Nonincendive: Class I, Div. 2, Groups A, B, C, D
 - Intrinsically safe: Class I, II, III, Div. 1, Groups A, B, C, D, E, F, G
 - AEx ia IIC T6/T4, Zone 0 (FM)
- STANDARDS AUSTRALIA (SAA): TS Approval
 - Intrinsically safe Ex ia IIC T4/T5 (-20°C ≤ Ta ≤ +80°C) only HART
 - No sparking Ex n IIC T4/T6 (-20°C ≤ Ta ≤ +80°C) only HART
 - Flameproof Ex d IIC T4/T6 (-20°C ≤ Ta ≤ +80°C)
 - Dust ignitionproof DIP A21 Ta T6 (-20°C ≤ Ta ≤ +80°C)
- INTRINSIC SAFETY/CHINA
 - NEPSI approval Ex ia IIC T4-T6
- FLAMEPROOF/CHINA
 - NEPSI approval Ex d IIC T6
- GOST (Russia), GOST (Kazakistan), Inmetro (Brazil) based on ATEX

Electrical Characteristics and Options

HART digital communication and 4 to 20mA output

Power Supply

The transmitter operates from 10.5 to 42VDC with no load and is protected against reverse polarity connection (additional load allows operations over 42VDC).

For EEx ia and other intrinsically safe approval power supply must not exceed 30VDC.

Ripple

20mV max on a 250Ω load as per HART specifications

MINIMUM OPERATING VOLTAGES

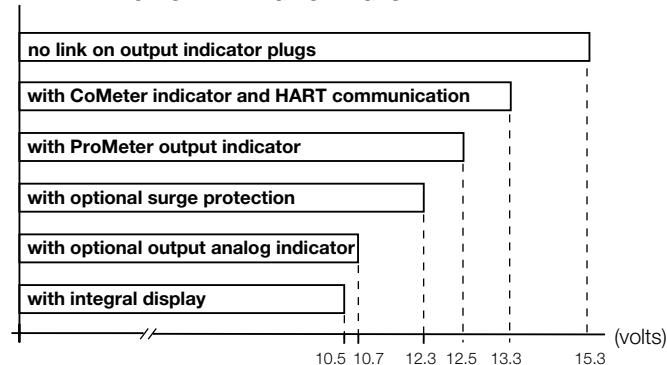

Load limitations

4 to 20mA and HART total loop resistance :

$$R(k\Omega) = \frac{\text{Supply voltage} - \text{min. operating voltage (VDC)}}{22.5}$$

A minimum of 250Ω is required for HART communication.

Optional indicators

Output meter

CoMeter and Prometer LCD :

5-digit (± 99999 counts) programmable with 7.6mm. high (3in), 7-segment numeric characters plus sign and digital point for digital indication of output value in percentage, current or engineer unit;

10-segment bargraph display (10% per segment) for analog indication of output in percentage;

7-digit with 6mm. high (2.3in), 14-segment alphanumeric characters, for engineer units and configuration display

Analog : 36mm (1.4in) scale on 90°.

Integral display

LCD, 15 lines x 56 column dot matrix providing 2 lines indication as

– top: 5-digit (numeric) plus sign or 7-digit alphanumeric

– bottom: 7-digit alphanumeric

and additional 50-segment bargraph for indication of analog output in percentage.

User-definable matrix display mode with HART communication:

– process variable in pressure unit or

– output signal as percentage, current or engineering units

Display also indicates in/out transfer function, static pressure, sensor temperature and diagnostic messages and provides configuration facilities.

Optional surge protection

Up to 4kV

– voltage 1.2 μs rise time / 50 μs delay time to half value

– current 8 μs rise time / 20 μs delay time to half value

Output signal

Two-wire 4 to 20mA, user-selectable for linear or square root output, power of $3/2$ or $5/2$, 5th order or two 2nd order switching point selectable programmable polynomial output.

HART® communication provides digital process variable (% , mA or engineering units) superimposed on 4 to 20mA signal, with protocol based on Bell 202 FSK standard.

Output current limits (to NAMUR standard)

Overload condition

- Lower limit: 3.8mA

- Upper limit: 20.5mA

Transmitter failure mode (to NAMUR standard)

The output signal can be user-selected to a value of 3.7 or 22mA on gross transmitter failure condition, detected by self-diagnostics.

In case of CPU failure the output is driven <3.7mA or >22mA.

PROFIBUS PA output

Device type

Pressure transmitter compliant to Profiles 3.0 Class A & B; ident. number 052B HEX.

Power supply

The transmitter operates from 9 to 32VDC, polarity independent.

For EEx ia approval power supply must not exceed 17.5VDC. Intrinsic safety installation according to FISCO model.

Current consumption

operating (quiescent): 10.5mA

fault current limiting: 20mA max.

Output signal

Physical layer in compliance to IEC 1158-2/EN 61158-2 with transmission to Manchester II modulation, at 31.25kbit/sec.

Output interface

PROFIBUS PA communication according to Profibus DP50170 Part 2/ DIN 19245 part 1-3.

Output update time

25ms

Function blocks

2 analog input, 1 transducer, 1 physical

Integral display

LCD, 15 lines x 56 column dot matrix providing 2 lines indication as

– top: 5-digit (numeric) plus sign or 7-digit alphanumeric

– bottom: 7-digit alphanumeric

and additional 50-segment bargraph for indication of output in percentage of the analog input function block assigned to the primary variable.

User-definable matrix display mode:

– process variable in pressure units or

– primary variable in engineering units (output of transducer block) or

– output as percentage or engineering units of analog input function blocks

Display also indicates diagnostic messages and provides configuration facilities.

Secondary variable, static pressure and sensor temperature can be read.

Transmitter failure mode

On gross transmitter failure condition, detected by self-diagnostics, the output signal can be driven to defined conditions, selectable by the user as safe, last valid or calculated value. If electronic failure or short circuit occur the transmitter consumption is electronically limited at a defined value (20mA approx), for safety of the network.

FOUNDATION Fieldbus output

Device type

LINK MASTER DEVICE

Link Active Scheduler (LAS) capability implemented.

Power supply

The transmitter operates from 9 to 32VDC, polarity independent.

For EEx ia approval power supply must not exceed 24VDC (entity certification) or 17.5VDC (FISCO certification), according to FF-816.

Current consumption

operating (quiescent): 10.5mA

fault current limiting: 20mA max.

Output signal

Physical layer in compliance to IEC 1158-2/EN 61158-2 with transmission to Manchester II modulation, at 31.25kbit/sec.

Function blocks/execution period

2 enhanced Analog Input blocks/25ms max (each)

1 enhanced PID block/40ms max.

1 standard ARithmetic block/25ms

1 standard Input Selector block/25ms

1 standard Control Selector block/25ms

1 standard Signal Characterization block/25ms

1 standard Integrator/Totalizer block/25ms

Additional blocks

1 enhanced Resource block

1 custom Pressure with calibration transducer block

1 custom Advanced Diagnostics transducer block including Plugged Input Line Detection

1 custom Local Display transducer block

Number of link objects

35

Number of VCRs

35

Output interface

FOUNDATION fieldbus digital communication protocol to standard H1, compliant to specification V. 1.6; FF registration in progress.

Integral display

LCD, 15 lines x 56 column dot matrix providing 2 lines indication as

– top: 5-digit (numeric) plus sign or 7-digit alphanumeric

– bottom: 7-digit alphanumeric

and additional 50-segment bargraph for percentage indication of the analog input function block output, assigned to the primary variable.

User-definable matrix display mode:

– process variable in pressure units or

– primary variable in engineering units (output of transducer block) or

– output as percentage or engineering units of one or more selected function blocks

Display also indicates diagnostic messages. Secondary variable, static pressure and sensor temperature can be read.

Transmitter failure mode

The output signal is "frozen" to the last valid value on gross transmitter failure condition, detected by self-diagnostics which also indicate a BAD conditions. If electronic failure or short circuit occur the transmitter consumption is electronically limited at a defined value (20mA approx), for safety of the network.

Performance specifications

Stated at reference condition to IEC 60770 ambient temperature of 20°C (68°F), relative humidity of 65%, atmospheric pressure of 1013hPa (1013mbar), mounting position with vertical diaphragm and zero based range for transmitter with isolating diaphragms in AISI 316 L ss or Hastelloy and silicone oil fill and HART digital trim values equal to 4–20mA span end points, in linear mode.

Unless otherwise specified, errors are quoted as % of span.

Some performance data are affected by the actual turndown (TD) as ratio between Upper Range Limit (URL) and calibrated span.

IT IS RECOMMENDED TO SELECT THE TRANSMITTER SENSOR CODE PROVIDING THE TURNDOWN VALUE AS LOWEST AS POSSIBLE TO OPTIMIZE PERFORMANCE CHARACTERISTICS.

Accuracy rating

% of calibrated span, including combined effects of terminal based linearity, hysteresis and repeatability.

For fieldbus versions SPAN refer to analog input function block outscale range

– ±0.075% for TD from 1:1 to 10:1

– ±0.15% for TD from 1:1 to 5:1 for sensor code H with 1in seal sizes

– ±0.0075% x $\frac{\text{URL}}{\text{Span}}$ for TD from 10:1 to 20:1

– ±0.03% x $\frac{\text{URL}}{\text{Span}}$ for TD from 5:1 to 10:1 for sensor code H with 1in seal sizes

Operating influences

Temperature effect

per 20K (36°F) ambient temperature change on transmitter sensor between the limits of –20°C to +65°C (–4 to +150°F) :

Seal type size	Error
1in all types	± (0.20% URL + 0.20% span)
1 1/2in all types	± (0.15% URL + 0.15% span)

per 20K (36°F) process temperature change on seal diaphragm between the process operating temperature limits limits of –25°C to 120°C (–13°F to 248°F):

Seal type size	Error		
	kPa	mbar	inH ₂ O
1in (except ball valve type)	0.6	6	2.4
1in with ball valve connection	1.2	12	4.8
1 1/2in all types	0.2	2	0.8

Multiply by 1.5 the above values for 20K (36°F) change between the limits of –40 to –25°C (–40 to –13°F) and of +120 to +150°C (+248 to 302°F).

Optional CoMeter and ProMeter ambient temperature

Total reading error per 20K (36°F) change between the ambient limits of –20 and +70°C (–4 and +158°F) :

±0.15% of max span (16mA).

Supply voltage

Within voltage/load specified limits the total effect is less than 0.005% of URL per volt.

Load

Within load/voltage specified limits the total effect is negligible.

Electromagnetic field

Total effect : less than 0.10% of span from 20 to 1000MHz and for field strengths up to 30V/m when tested with shielded conduit and grounding, with or without meter.

Common mode interference

No effect from 100Vrms @ 50Hz, or 50VDC

Vibration effect

±0.10% of URL (according to IEC 61298–3)

Physical Specification

(Refer to ordering information sheets for variant availability related to specific model or versions code)

Materials

High pressure side process diaphragm (direct mount seal) (*)

AISI 316 L ss; Hastelloy C276™;

Diaflex (AISI with anti-abrasion treatment).

High pressure side fill fluid (direct mount seal)

Silicone oil-DC200™; Mineral oil-MARCOL 82™.

Process connection (*)

AISI 316 L ss

Gaskets (*)

Viton™ for 1in and 1 1/2in seal sizes (sealing with gasket)

PTFE for 1 1/2in seal size (sealing with gasket to M44 threaded spud)

Spud (where supplied if applicable)

AISI 316 L ss

Sensor fill fluid

Silicone oil (DC200™).

Sensor housing

AISI 316 L ss.

Electronic housing and covers

Barrel version

– Aluminium alloy with baked epoxy finish;

– Copper-free content aluminium alloy with baked epoxy finish;

– AISI 316 L ss.

Covers O-ring

Buna N.

Local zero and span adjustments:

Glass filled polycarbonate plastic (removable).

Tagging

AISI 316ss data plate attached to the electronics housing.

Calibration

Standard: at maximum span, zero based range, ambient temperature and pressure;

Optional: at specified range and ambient conditions.

Optional extras

Output indicator

plug-in rotatable type, LCD or analog.

Supplemental customer tag

AISI 316 ss tag screwed/fastened to the transmitter for customer's tag data up to a maximum of 20 characters and spaces on one line for tag number and tag name, and up to a maximum of 3 spaced strings of 10 characters each for calibration details (lower and upper values plus unit). Special typing evaluated on request for charges.

Surge protection (only as external unit for PROFIBUS PA and FF)

Tank spud

Test Certificates (test, design, calibration, material traceability)

Tag and manual language

Communication connectors

Process connections

Pulp & paper seal

- 1in sealing with gasket for weld spud with fixing by screw
- 1 1/2in sealing with gasket for weld spud with fixing by screws
- 1 1/2in sealing with gasket for weld spud with M44 x 1.25 threaded connection
- 1in or 1 1/2in with NPT male threaded connection
- G 1in A or G 1 1/2in A male threaded connection
- 1in for ball valve connection

Electrical connections

Two 1/2 – 14 NPT or M20x1.5 or PG 13.5 or 1/2 GK threaded conduit entries, direct on housing.

Special communication connector (on request)

– HART : straight or angle Harting Han connector and one plug.

– FOUNDATION Fieldbus, PROFIBUS PA: M12x1 and 7/8.

Terminal block

HART version: three terminals for signal/external meter wiring up to 2.5mm² (14AWG) and three connection points for test and communication purposes.

Fieldbus versions: two terminals for signal wiring (bus connection) up to 2.5mm² (14AWG)

Grounding

Internal and external 6mm² (10AWG) ground termination points are provided.

Mounting position

Transmitter can be mounted in any position.

Electronics housing may be rotated to any position. A positive stop prevents over travel.

Mass (without options)

2.5kg to 3kg approx (5 to 6lb) according to specified seal(s) options; add 1.5kg (3.4lb) for AISI housing.

Add 650g (1.5lb) for packing.

Packing

Carton

(*) Wetted parts of the transmitter.

Configuration

Transmitter with HART communication and 4 to 20 mA

Standard configuration

Transmitters are factory calibrated to customer's specified range. Calibrated range and tag number are stamped on the tag plate. If a calibration range and tag data are not specified, the transmitter will be supplied with the plate left blank and configured as follows:

Engineering Unit	kPa
4 mA	Zero
20 mA	Upper Range Limit (URL)
Output	Linear
Damping	1 sec.
Transmitter failure mode	Upscale
Software tag (8 characters max)	Blank
Optional LCD indicator/display	0 to 100.0% linear

Any or all the above configurable parameters, including Lower range-value and Upper range-value which must be the same unit of measure, can be easily changed using the HART hand-held communicator or by a PC running the configuration software SMART VISION with DTM for 2600T. The transmitter database is customized with specified flange type and material, O-ring and drain/vent materials and meter code option.

Custom configuration (option)

The following data may be specified in addition to the standard configuration parameters:

Descriptor	16 alphanumeric characters
Message	32 alphanumeric characters
Date	Day, month, year

Transmitter with PROFIBUS PA communication

Transmitters are factory calibrated to customer's specified range. Calibrated range and tag number are stamped on the tag plate. If a calibration range and tag data are not specified, the transmitter will be supplied with the plate left blank and configured as follows:

Measure Profile	Pressure
Engineering Unit	kPa
Output scale 0%	Lower Range Limit (LRL)
Output scale 100%	Upper Range Limit (URL)
Output	Linear
Hi-Hi Limit	Upper Range Limit (URL)
Hi Limit	Upper Range Limit (URL)
Low Limit	Lower Range Limit (LRL)
Low-Low Limit	Lower Range Limit (LRL)
Limits hysteresis	0.5% of output scale
PV filter	0 sec.
Address (settable by local key)	126
Tag	32 alphanumeric characters

Any or all the above configurable parameters, including Lower range-value and Upper range-value which must be the same unit of measure, can be easily changed by a PC running the configuration software SMART VISION with DTM for 2600T.

The transmitter database is customized with specified flange type and material, O-ring and drain/vent materials and meter code option.

Custom configuration (option)

The following data may be specified in addition to the standard configuration parameters:

Descriptor	32 alphanumeric characters
Message	32 alphanumeric characters
Date	Day, month, year

Transmitter with FOUNDATION Fieldbus communication

Transmitters are factory calibrated to customer's specified range. Calibrated range and tag number are stamped on the tag plate. If a calibration range and tag data are not specified, the transmitter will be supplied with the plate left blank and the analog input function block FB1 is configured as follows:

Measure Profile	Pressure
Engineering Unit	kPa
Output scale 0%	Lower Range Limit (LRL)
Output scale 100%	Upper Range Limit (URL)
Output	Linear
Hi-Hi Limit	Upper Range Limit (URL)
Hi Limit :	Upper Range Limit (URL)
Low Limit	Lower Range Limit (LRL)
Low-Low Limit	Lower Range Limit (LRL)
Limits hysteresis	0.5% of output scale
PV filter time	0 sec.
Tag	32 alphanumeric characters

The analog input function block FB2 is configured for the sensor temperature measured in °C. Any or all the above configurable parameters, including the range values, can be changed using any host compliant to FOUNDATION fieldbus. The transmitter database is customized with specified flange type and material, O-ring and drain/vent materials and meter code option.

For any protocol available engineering units of pressure measure are :

Pa, kPa, MPa
 inH₂O@4°C, mmH₂O@4°C, psi
 inH₂O@20°C, ftH₂O@20°C, mmH₂O@20°C
 inHg, mmHg, Torr
 g/cm², kg/cm², atm
 mbar, bar

MOUNTING DIMENSIONS (not for construction unless certified) – dimensions in mm (in)

264HP/NP with pulp and paper seal - 1 in size to spud with screw fixing

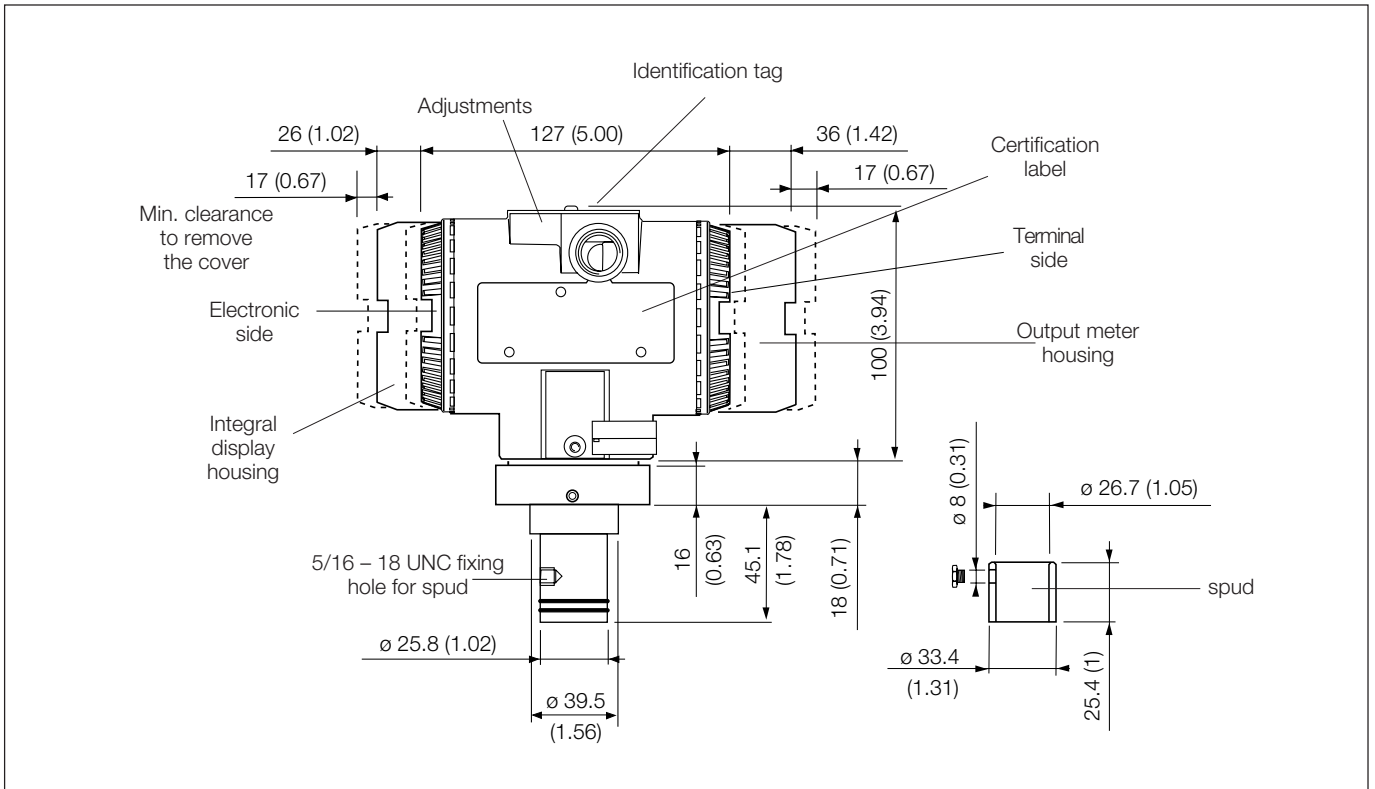

264HP/NP with pulp and paper seal - 1 1/2 in size to spud with screws fixing

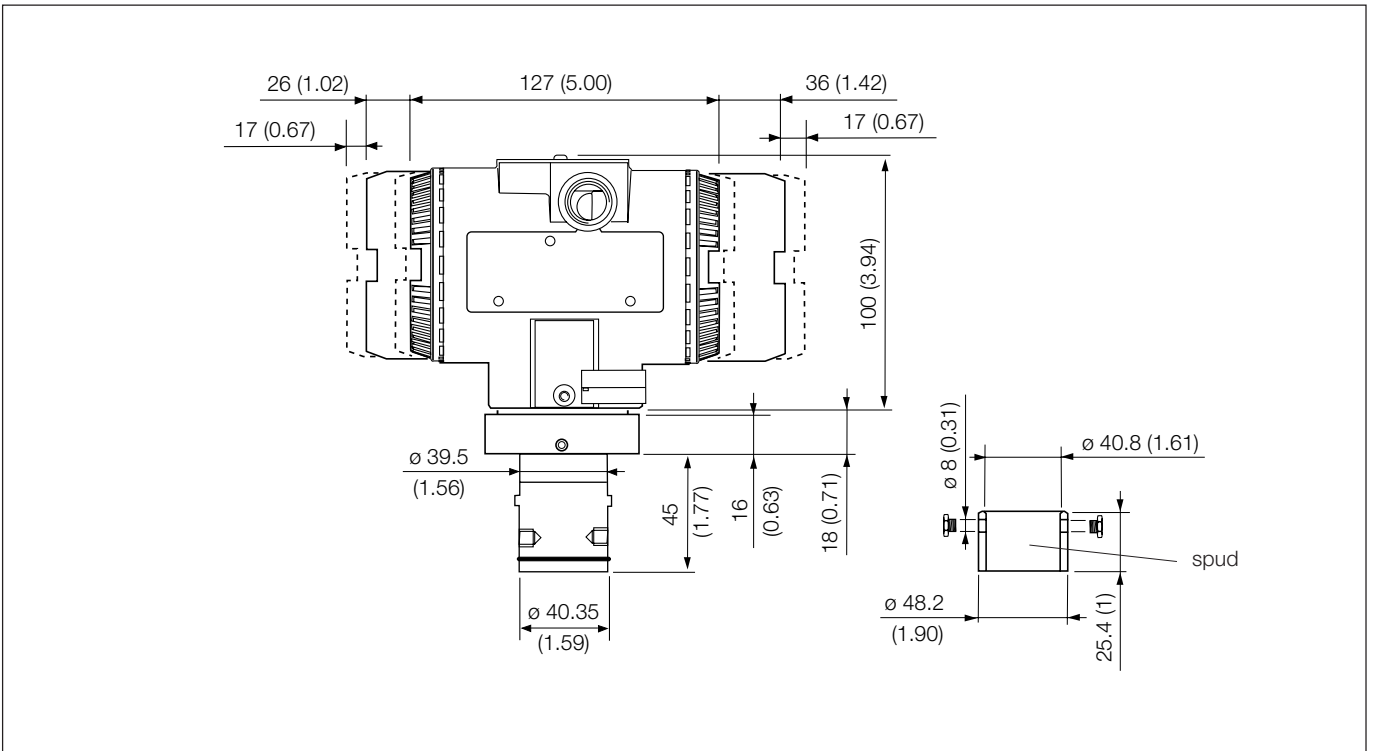

264HP/NP with pulp and paper seal - 1 in with ball valve connection

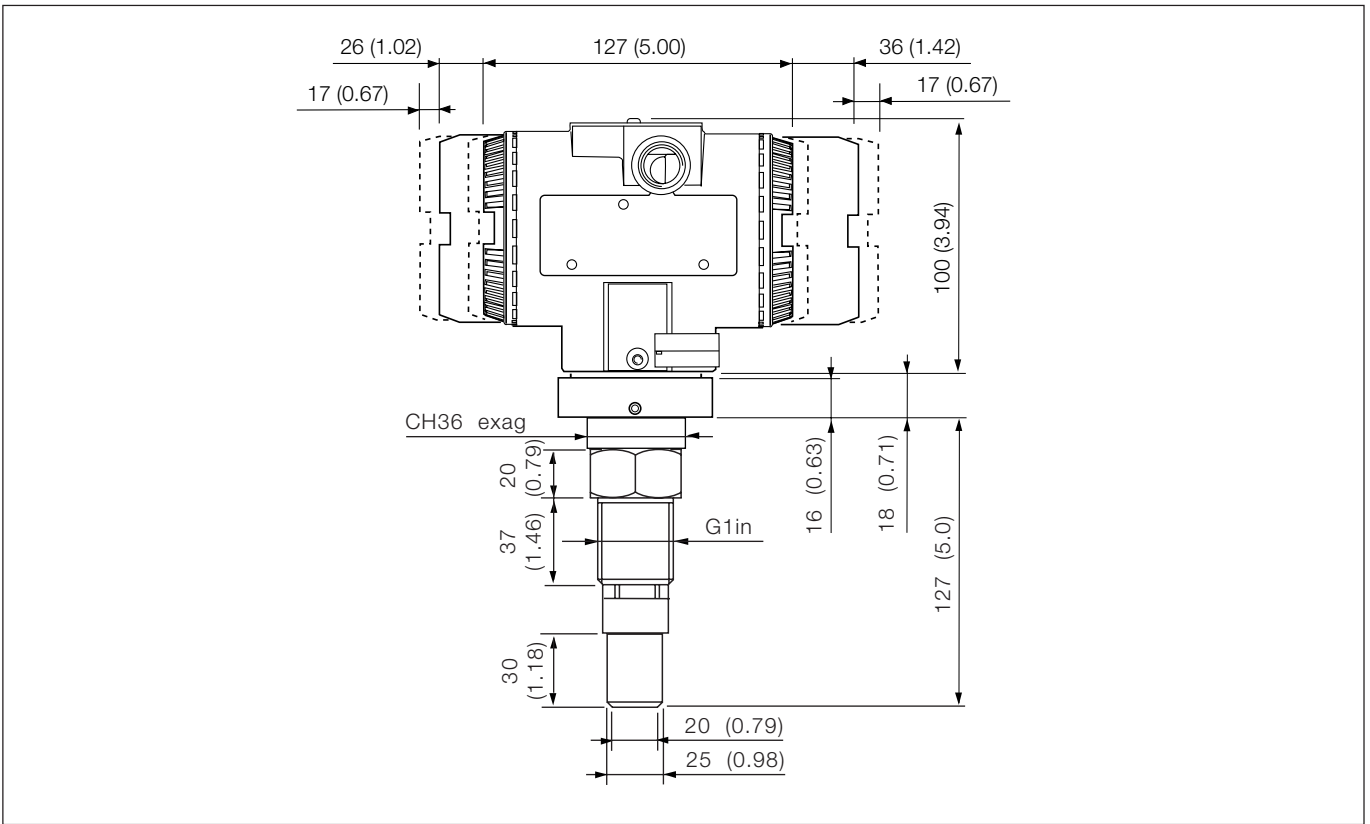

264HP/NP with pulp and paper seal - 1 in and 1 1/2 in size with G 1 in A and G 1 1/2 in A threaded connection

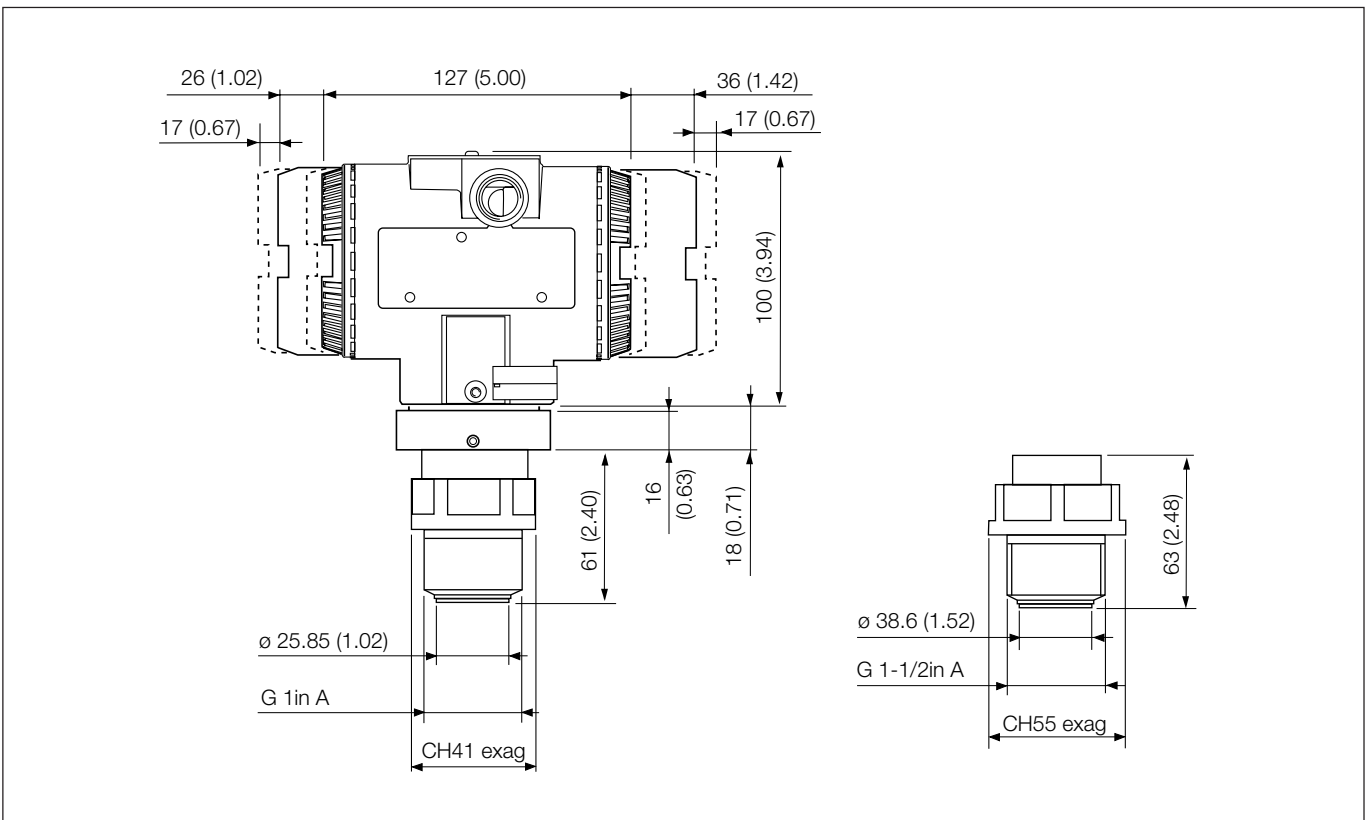

Electrical connections

HART Version

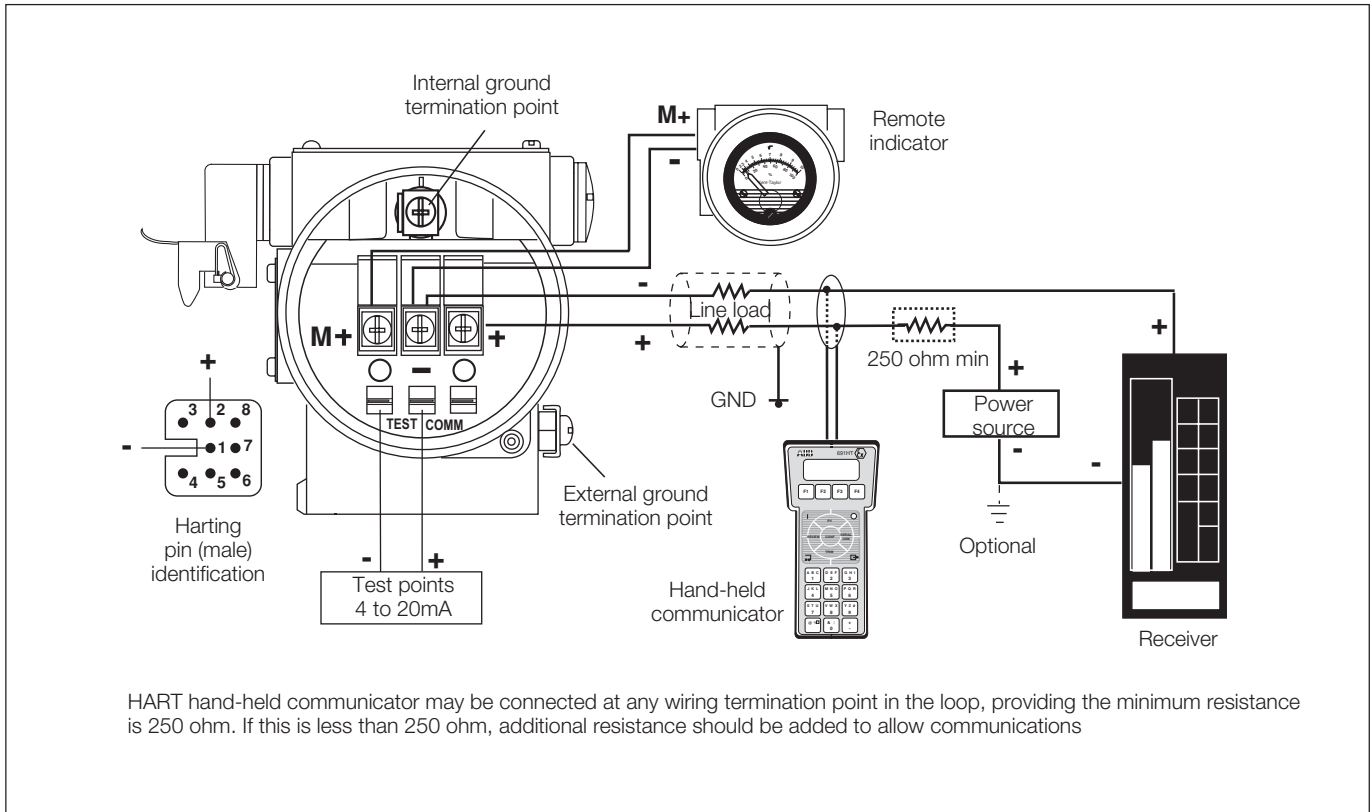

FIELD BUS Versions

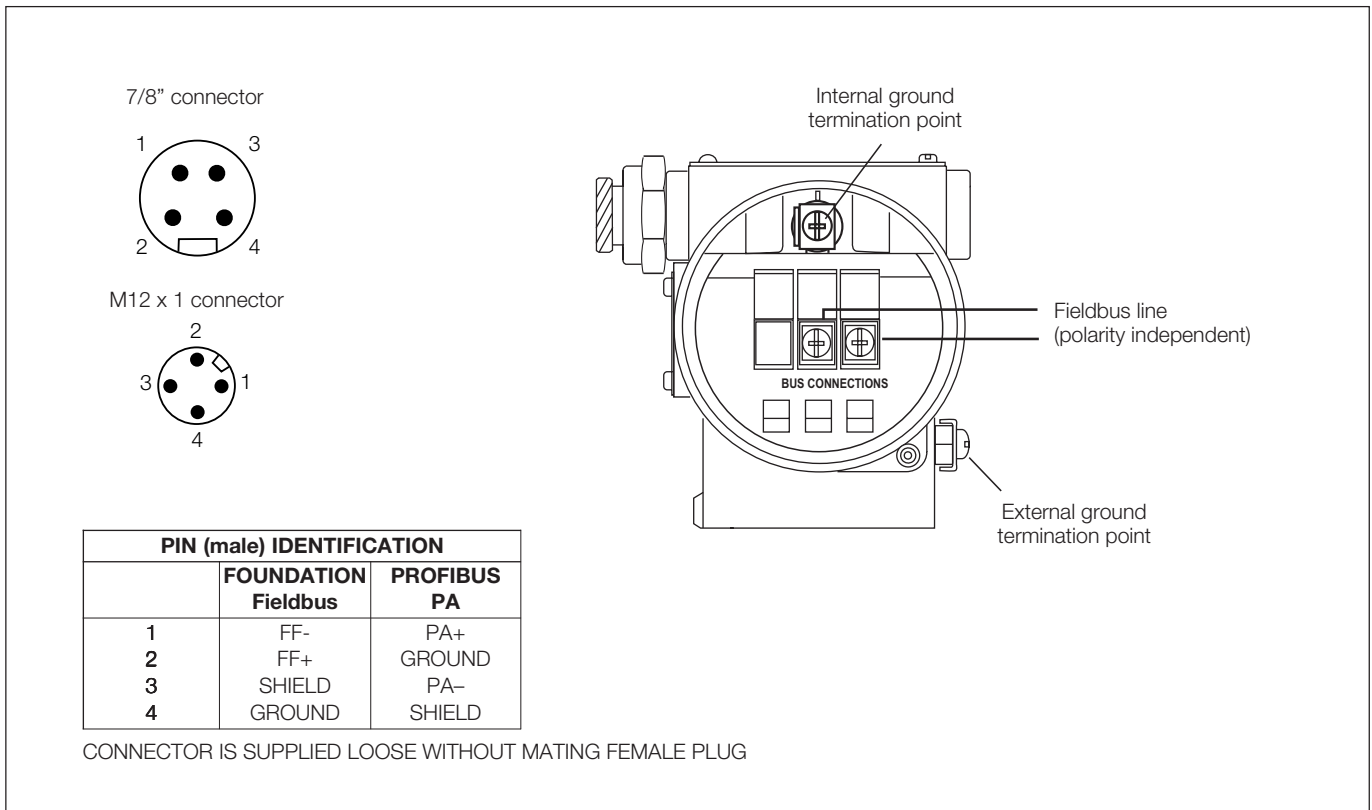

BASIC ORDERING INFORMATION model 264HP Gauge Pressure Transmitter with pulp and paper direct mount seal

Select one character or set of characters from each category and specify complete catalog number.

Refer to additional ordering information code and specify one or more codes for each transmitter if additional options are required.

BASE MODEL – 1 st to 5 th characters				2	6	4	H	P	X	X	X	X	X	X	X
Gauge Pressure Transmitter with pulp and paper direct mount seal – BASE ACCURACY 0.075%															
SENSOR - Span limits – 6th character															
1.1 and 65kPa	11 and 650mbar	4.35 and 260inH ₂ O	(Not available for 1in seal sizes)						G						
2.67 and 160kPa	26.7 and 1600mbar	10.7 and 642inH ₂ O							H						
10 and 600kPa	0.1 and 6bar	1.45 and 87psi							M						
40 and 2400kPa	0.4 and 24bar	5.8 and 348psi							P						
134 and 8000kPa	1.34 and 80bar	19.4 and 1160psi							Q						
267 and 16000kPa	2.67 and 160bar	38.7 and 2320psi	(Only available with 1in and 1 1/2in male threads)						S						
Diaphragm material/Fill Fluid (not wetted) – 7th character															
AISI 316 L ss	Silicone oil									R					
HIGH PRESSURE SIDE - Size/Mounting connection – 8th character															
1in pulp and paper seal - sealing with gaskets to spud			(Notes 1, 2)												U
1 1/2in pulp and paper seal - sealing with gasket to spud			(Note 2)												K
1in pulp and paper seal with 1in NPT male threaded connection			(Note 1)												W
1 1/2in pulp and paper seal with 1 1/2in NPT male threaded connection															Z
1in pulp and paper seal with G 1in A male threaded connection			(Note 1)												1
1 1/2in pulp and paper seal with G 1 1/2in A male threaded connection															2
1in pulp and paper seal with ball valve connection			(Notes 1, 2)												Y
1 1/2in pulp and paper seal - sealing with gasket to M44 threaded spud			(Note 2)												V
HIGH PRESSURE SIDE – Diaphragm material (wetted parts) (seal) – 9th character															
AISI 316 L ss			(Note 3)												S
Hastelloy C276™															H
Diaflex (AISI with anti abrasion treatment)			(Note 3)												U
HIGH PRESSURE SIDE – Fill fluid – 10th character															
Silicone oil															S
Mineral oil (FDA approved)															W
Housing material and electrical connection – 11th character															
Aluminium alloy (Barrel version)		1/2 – 14 NPT													A
Aluminium alloy (Barrel version)		M20 x 1.5 (CM 20)													B
Aluminium alloy (Barrel version)		Pg 13.5													D
Aluminium alloy (Barrel version)		1/2 GK													C
Aluminium alloy (Barrel version)		Harting Han connector (general purpose only)								(Note 4)					E
Aluminium alloy (Barrel version)		Fieldbus connector (general purpose only)								(Note 4)					G
Aluminium alloy copper-free (Barrel version)		1/2 – 14 NPT													H
Aluminium alloy copper-free (Barrel version)		M20 x 1.5 (CM 20)													L
Aluminium alloy copper-free (Barrel version)		Pg 13.5													N
Aluminium alloy copper-free (Barrel version)		1/2 GK													M
Aluminium alloy copper-free (Barrel version)		Harting Han connector (general purpose only)								(Note 4)					P
Aluminium alloy copper-free (Barrel version)		Fieldbus connector (general purpose only)								(Note 4)					R
AISI 316 L ss (Barrel version)		1/2 – 14 NPT													S
AISI 316 L ss (Barrel version)		M20 x 1.5 (CM20)													T
AISI 316 L ss (Barrel version)		Pg 13.5													V
AISI 316 L ss (Barrel version)		1/2 GK													U
AISI 316 L ss (Barrel version)		Fieldbus connector (general purpose only)								(Note 4)					Z
Output/Additional options – 12th character															
HART digital communication and 4 to 20mA	No additional options									(Notes 5, 6)					H
HART digital communication and 4 to 20mA	Options requested (to be ordered by "Additional ordering code")									(Note 5)					1
PROFIBUS PA	No additional options									(Notes 5, 6)					P
PROFIBUS PA	Options requested (to be ordered by "Additional ordering code")									(Note 6)					2
FOUNDATION Fieldbus	No additional options									(Notes 5, 6)					F
FOUNDATION Fieldbus	Options requested (to be ordered by "Additional ordering code")									(Note 6)					3

ADDITIONAL ORDERING INFORMATION for model 264HP

Add one or more 2-digit code(s) after the basic ordering information to select all required options

	XX	XX	XX	XX	XX	XX	XX	XX	XX	XX	XX	XX
Electrical certification												
ATEX Group II Category 1 GD – Intrinsic Safety EEx ia	E1											
ATEX Group II Category 1/2 GD – Flameproof EEx d	E2											
ATEX Group II Category 3 GD – Type of protection "N" EEx nL design compliance (Note 7)	E3											
Canadian Standard Association (CSA) (only 1/2–14NPT, M20 and Pg 13.5 electrical connection)	E4											
Standards Australia SAA (Not Ex ia and Ex n for PROFIBUS PA and FOUNDATION Fieldbus)	E5											
Factory Mutual (FM) approval (only with 1/2–14NPT, M20 and Pg 13.5 electrical connection)	E6											
Combined ATEX - Intrinsic Safety and Flameproof	E7											
Combined ATEX, FM and CSA (only with 1/2–14NPT, M20 and Pg 13.5 electrical connection) (Note 7)	EN											
NEPSI (China) - Intrinsic Safety Ex ia	EY											
NEPSI (China) - Flameproof Ex d	EZ											
GOST (Russia) EEx ia	W1											
GOST (Russia) EEx d	W2											
GOST (Kazakistan) EEx ia	W3											
GOST (Kazakistan) EEx d	W4											
Inmetro (Brazil) EEx ia (Note 7)	W5											
Inmetro (Brazil) EEx d (Note 7)	W6											
Inmetro (Brazil) EEx nL (Note 7)	W7											
Output meter												
ProMeter, Standard calibration (Note 7)	D1											
ProMeter, Special calibration (Note 7)	D2											
Analog output indicator linear 0–100% scale (Note 7)	D3											
Analog output indicator, special graduation (to be specified for linear scale) (Note 7)	D5											
Programmable signal meter and HART configurator (CoMeter) (Note 7)	D7											
Programmable signal meter and HART configurator (CoMeter – customer configuration) (Note 7)	D8											
Integral LCD												
Digital LCD integral display										L1		
Surge												
Surge/Transient Protector (Internal for HART / 4-20mA)												
Surge/Transient Protector (External supplied loose for PROFIBUS PA and FOUNDATION Fieldbus only suitable with 1/2–14NPT and M20 electrical connection and with ATEX, FM and CSA certifications, no DUST)										S1		
Operating manual												
German											M1	
Italian											M2	
Spanish											M3	
French											M4	
Labels & tag language												
German											T1	
Italian											T2	
Spanish											T3	
French											T4	
Additional tag plate												
Laser printing of tag on stainless steel plate											I2	
Configuration												
Standard – Pressure = inH ₂ O/psi at 20° C; Temperature = deg. F											N2	
Standard – Pressure = inH ₂ O/psi at 4° C; Temperature = deg. F											N3	
Standard – Pressure = inH ₂ O/psi at 20° C; Temperature = deg.C											N4	
Standard – Pressure = inH ₂ O/psi at 4° C; Temperature = deg. C											N5	
Custom											N6	
Certificates												
Inspection certificate EN 10204–3.1 of calibration (9-point)											C1	
Certificate of compliance with the order EN 10204–2.1 of instrument design											C6	
Material traceability												
Certificate of compliance with the order EN 10204–2.1 of process wetted parts											H1	
Inspection certificate EN 10204–3.1 of process wetted parts											H3	
Connector												
Fieldbus 7/8 (Recommended for FOUNDATION Fieldbus) - (supplied loose without mating female plug)									(Notes 6, 8)		U1	
Fieldbus M12x1 (Recommended for PROFIBUS PA) - (supplied loose without mating female plug)									(Notes 6, 8)		U2	
Harting Han – straight entry									(Notes 5, 8)		U3	
Harting Han – angle entry									(Notes 5, 8)		U4	
Clamp/Fittings												
Spud and fixing screw for 1in pulp & paper seal connection									(Note 9)		JC	
Threaded spud for 1 1/2in pulp & paper seal connection									(Note 10)		JD	
Spud and fixing screws for 1 1/2 in pulp & paper seal connection									(Note 11)		JF	

- Note 1: Not available with Sensor code G
- Note 2: Not available with Sensor code S
- Note 3: Not available with 1in seal size with ball valve connection code Y
- Note 4: Select type in additional ordering code
- Note 5: Not available with Electronic Housing code Z, R, G
- Note 6: Not available with Electronic Housing code P, E
- Note 7: Not available with PROFIBUS PA and FF output code 2 or 3
- Note 8: Not available with Electronic housing code U, S, T, V, H, M, L, N, D, C, A, B
- Note 9: Suitable ONLY for 1in size - sealing with gaskets code U
- Note 10: Suitable ONLY for 1-1/2in size to M44 threaded spud - sealing with gaskets code V
- Note 11: Suitable ONLY for 1-1/2in size - sealing with gaskets code K

Standard delivery items (can be differently specified by additional ordering code)

- General purpose (no electrical certification)
- No meter/display, no mounting bracket, no surge protection
- English manual and labels
- Configuration with kPa and deg. C units
- No test, inspection or material traceability certificates

THE SELECTION OF SUITABLE WETTED PARTS AND FILLING FLUID FOR COMPATIBILITY WITH THE PROCESS MEDIA IS A CUSTOMER'S RESPONSIBILITY, IF NOT OTHERWISE NOTIFIED BEFORE MANUFACTURING.

BASIC ORDERING INFORMATION model 264NP Absolute Pressure Transmitter with pulp & paper direct mount seal

Select one character or set of characters from each category and specify complete catalog number.

Refer to additional ordering information code and specify one or more codes for each transmitter if additional options are required.

BASE MODEL – 1 st to 5 th characters				2	6	4	N	P	X	X	X	X	X	X
Absolute Pressure Transmitter with pulp and paper direct mount seal – BASE ACCURACY 0.075%														
SENSOR - Span limits – 6th character														
1.1 and 65kPa	11 and 650mbar	8 and 480mmHg	(Not available for 1in seal sizes)						G					
2.67 and 160kPa	26.7 and 1600mbar	20 and 1200mmHg							H					
10 and 600kPa	0.1 and 6bar	1.45 and 87psi							M					
40 and 2400kPa	0.4 and 24bar	5.8 and 348psi							P					
134 and 8000kPa	1.34 and 80bar	19.4 and 1160psi							Q					
267 and 16000kPa	2.67 and 160bar	38.7 and 2320psi	(Only available with 1in and 1 1/2in male threads)						S					
Diaphragm material/Fill Fluid (not wetted) – 7th character														
AISI 316 L ss	Silicone oil									R				
HIGH PRESSURE SIDE - Size/Mounting connection – 8th character														
1in pulp and paper seal - sealing with gaskets to spud			(Notes 1, 2)								U			
1 1/2in pulp and paper seal - sealing with gasket to spud			(Note 2)								K			
1in pulp and paper seal with 1in NPT male threaded connection			(Note 1)								W			
1 1/2in pulp and paper seal with 1 1/2in NPT male threaded connection											Z			
1in pulp and paper seal with G 1in A male threaded connection			(Note 1)								1			
1 1/2in pulp and paper seal with G 1 1/2in A male threaded connection											2			
1 1/2in pulp and paper seal - sealing with gasket to M44 threaded spud			(Note 2)								V			
HIGH PRESSURE SIDE – Diaphragm material (wetted parts) (seal) – 9th character														
AISI 316 L ss			(Note 3)									S		
Hastelloy C276™												H		
Diaflex (AISI with anti abrasion treatment)			(Note 3)									U		
HIGH PRESSURE SIDE – Fill fluid – 10th character														
Silicone oil													S	
Mineral oil (FDA approved)													W	
Housing material and electrical connection – 11th character														
Aluminium alloy (Barrel version)		1/2 – 14 NPT												A
Aluminium alloy (Barrel version)		M20 x 1.5 (CM 20)												B
Aluminium alloy (Barrel version)		Pg 13.5												D
Aluminium alloy (Barrel version)		1/2 GK												C
Aluminium alloy (Barrel version)		Harting Han connector (general purpose only)								(Note 4)				E
Aluminium alloy (Barrel version)		Fieldbus connector (general purpose only)								(Note 4)				G
Aluminium alloy copper-free (Barrel version)		1/2 – 14 NPT												H
Aluminium alloy copper-free (Barrel version)		M20 x 1.5 (CM 20)												L
Aluminium alloy copper-free (Barrel version)		Pg 13.5												N
Aluminium alloy copper-free (Barrel version)		1/2 GK												M
Aluminium alloy copper-free (Barrel version)		Harting Han connector (general purpose only)								(Note 4)				P
Aluminium alloy copper-free (Barrel version)		Fieldbus connector (general purpose only)								(Note 4)				R
AISI 316 L ss (Barrel version)		1/2 – 14 NPT												S
AISI 316 L ss (Barrel version)		M20 x 1.5 (CM20)												T
AISI 316 L ss (Barrel version)		Pg 13.5												V
AISI 316 L ss (Barrel version)		1/2 GK												U
AISI 316 L ss (Barrel version)		Fieldbus connector (general purpose only)								(Note 4)				Z
Output/Additional options – 12th character														
HART digital communication and 4 to 20mA		No additional options								(Notes 5, 6)				H
HART digital communication and 4 to 20mA		Options requested (to be ordered by "Additional ordering code")								(Note 5)				1
PROFIBUS PA		No additional options								(Notes 5, 6)				P
PROFIBUS PA		Options requested (to be ordered by "Additional ordering code")								(Note 6)				2
FOUNDATION Fieldbus		No additional options								(Notes 5, 6)				F
FOUNDATION Fieldbus		Options requested (to be ordered by "Additional ordering code")								(Note 6)				3

ADDITIONAL ORDERING INFORMATION for model 264NP

Add one or more 2-digit code(s) after the basic ordering information to select all required options

	XX	XX	XX	XX	XX	XX	XX	XX	XX	XX	XX	XX
Electrical certification												
ATEX Group II Category 1 GD – Intrinsic Safety EEx ia	E1											
ATEX Group II Category 1/2 GD – Flameproof EEx d	E2											
ATEX Group II Category 3 GD – Type of protection "N" EEx nL design compliance (Note 7)	E3											
Canadian Standard Association (CSA) (only 1/2–14NPT, M20 and Pg 13.5 electrical connection)	E4											
Standards Australia SAA (Not Ex ia and Ex n for PROFIBUS PA and FOUNDATION Fieldbus)	E5											
Factory Mutual (FM) approval (only with 1/2–14NPT, M20 and Pg 13.5 electrical connection)	E6											
Combined ATEX - Intrinsic Safety and Flameproof	E7											
Combined ATEX, FM and CSA (only with 1/2–14NPT, M20 and Pg 13.5 electrical connection) (Note 7)	EN											
NEPSI (China) - Intrinsic Safety Ex ia	EY											
NEPSI (China) - Flameproof Ex d	EZ											
GOST (Russia) EEx ia	W1											
GOST (Russia) EEx d	W2											
GOST (Kazakistan) EEx ia	W3											
GOST (Kazakistan) EEx d	W4											
Inmetro (Brazil) EEx ia (Note 7)	W5											
Inmetro (Brazil) EEx d (Note 7)	W6											
Inmetro (Brazil) EEx nL (Note 7)	W7											
Output meter												
ProMeter, Standard calibration (Note 7)	D1											
ProMeter, Special calibration (Note 7)	D2											
Analog output indicator linear 0–100% scale (Note 7)	D3											
Analog output indicator, special graduation (to be specified for linear scale) (Note 7)	D5											
Programmable signal meter and HART configurator (CoMeter) (Note 7)	D7											
Programmable signal meter and HART configurator (CoMeter – customer configuration) (Note 7)	D8											
Integral LCD												
Digital LCD integral display										L1		
Surge												
Surge/Transient Protector (Internal for HART / 4-20mA)												
Surge/Transient Protector (External supplied loose for PROFIBUS PA and FOUNDATION Fieldbus only suitable with 1/2–14NPT and M20 electrical connection and with ATEX, FM and CSA certifications, no DUST)										S1		
Operating manual												
German											M1	
Italian											M2	
Spanish											M3	
French											M4	
Labels & tag language												
German											T1	
Italian											T2	
Spanish											T3	
French											T4	
Additional tag plate												
Laser printing of tag on stainless steel plate											I2	
Configuration												
Standard – Pressure = inH ₂ O/psi at 20° C; Temperature = deg. F												N2
Standard – Pressure = inH ₂ O/psi at 4° C; Temperature = deg. F												N3
Standard – Pressure = inH ₂ O/psi at 20° C; Temperature = deg. C												N4
Standard – Pressure = inH ₂ O/psi at 4° C; Temperature = deg. C												N5
Custom												N6
Certificates												
Inspection certificate EN 10204–3.1 of calibration (9-point)												C1
Certificate of compliance with the order EN 10204–2.1 of instrument design												C6
Material traceability												
Certificate of compliance with the order EN 10204–2.1 of process wetted parts												H1
Inspection certificate EN 10204–3.1 of process wetted parts												H3
Connector												
Fieldbus 7/8 (Recommended for FOUNDATION Fieldbus) - (supplied loose without mating female plug)										(Notes 6, 8)		U1
Fieldbus M12x1 (Recommended for PROFIBUS PA) - (supplied loose without mating female plug)										(Notes 6, 8)		U2
Harting Han – straight entry										(Notes 5, 8)		U3
Harting Han – angle entry										(Notes 5, 8)		U4
Clamp/Fittings												
Spud and fixing screw for 1in pulp & paper seal connection										(Note 9)		JC
Threaded spud for 1 1/2in pulp & paper seal connection										(Note 10)		JD
Spud and fixing screws for 1 1/2 in pulp & paper seal connection										(Note 11)		JF

2600T Pressure Transmitters

Model 264HP, 264NP

SS/264HP/NP_7

- Note 1: Select type in additional ordering code
- Note 2: Not available with Sensor code S
- Note 3: Not used
- Note 4: Select type in additional ordering code
- Note 5: Not available with Electronic Housing code Z, R, G
- Note 6: Not available with Electronic Housing code P, E
- Note 7: Not available with PROFIBUS PA and FF output code 2 or 3
- Note 8: Not available with Electronic housing code U, S, T, V, H, M, L, N, D, C, A, B
- Note 9: Suitable ONLY for 1in size - sealing with gaskets code U
- Note 10: Suitable ONLY for 1-1/2in size to M44 threaded spud - sealing with gaskets code V
- Note 11: Suitable ONLY for 1-1/2in size - sealing with gaskets code K

Standard delivery items (can be differently specified by additional ordering code)

- General purpose (no electrical certification)
- No meter/display, no mounting bracket, no surge protection
- English manual and labels
- Configuration with kPa and deg. C units
- No test, inspection or material traceability certificates

THE SELECTION OF SUITABLE WETTED PARTS AND FILLING FLUID FOR COMPATIBILITY WITH THE PROCESS MEDIA IS A CUSTOMER'S RESPONSIBILITY, IF NOT OTHERWISE NOTIFIED BEFORE MANUFACTURING.

™ Hastelloy is a Cabot Corporation trademark

™ Viton is a Dupont de Nemour trademark

™ DC200 is a Dow Corning Corporation trademark

™ Marcol is a Esso Italiana trademark

2600T Pressure Transmitters

Model 264HP, 264NP

ABB has Sales & Customer Support expertise in over 100 countries worldwide

www.abb.com/instrumentation

The Company's policy is one of continuous product improvement and the right is reserved to modify the information contained herein without notice.

Printed in Italy (03.08)

© ABB 2008



ABB Ltd
Howard Road, St. Neots
Cambridgeshire, PE19 8EU
UK
Tel: +44(0)1480 475321
Fax: +44(0)1480 217948

ABB Inc.
125 E. County Line Road
Warminster, PA 18974
USA
Tel: +1 215 674 6000
Fax: +1 215 674 7183

ABB SACE
A division of ABB S.p.A.
Via Statale 113
22016 Lenno (CO) Italy
Tel: +39 0344 58111
Fax: +39 0344 56278