

## 2600T Series Pressure Transmitters

Model 264DH Differential flange mounted  
maximum working pressure up to 5MPa, 725psi



- **Base accuracy :  $\pm 0.075\%$**
- **Span limits**
  - 0.27 to 2400kPa; 1.08inH<sub>2</sub>O to 348 psi
- **Reliable sensing system coupled with very latest digital technologies**
  - provides large turn down ratio up to 100:1
- **Comprehensive sensor choice**
  - optimize in-use total performance and stability
- **5-year stability**
- **Flexible configuration facilities**
  - provided locally via local keys combined with LCD indicator or via hand held terminal or PC configuration platform
- **Multiple protocol availability**
  - provides integration with HART®, PROFIBUS PA and FOUNDATION Fieldbus platforms offering interchangeability and transmitter upgrade capabilities
- **PED compliance to sound engineering practice (SEP)**



**ABB 2600T Series  
Engineered solutions  
for all applications**

## Functional Specifications

### Range and span limits

Sensor Code	Upper Range Limit (URL)	Lower Range Limit (LRL)	Minimum span
<b>E</b>	16kPa 160mbar 64inH <sub>2</sub> O	-16kPa -160mbar -64inH <sub>2</sub> O	0.27kPa 2.7mbar 1.08inH <sub>2</sub> O
<b>F</b>	40kPa 400mbar 160inH <sub>2</sub> O	-40kPa -400mbar -160inH <sub>2</sub> O	0.4kPa 4mbar 1.6inH <sub>2</sub> O
<b>G</b>	65kPa 650mbar 260inH <sub>2</sub> O	-65kPa -650mbar -260inH <sub>2</sub> O	0.65kPa 6.5mbar 2.6inH <sub>2</sub> O
<b>H</b>	160kPa 1600mbar 642inH <sub>2</sub> O	-160kPa -1600mbar -642inH <sub>2</sub> O	1.6kPa 16mbar 6.4inH <sub>2</sub> O
<b>M</b>	600kPa 6bar 87psi	-600kPa -6bar -87psi	6kPa 0.06bar 0.87psi
<b>P</b>	2400kPa 24bar 348psi	-2400kPa -24bar -348psi	24kPa 0.24bar 3.5psi

### Span limits

Maximum span = URL  
(can be further adjusted up to ± URL (TD = 0.5) for differential models, within the range limits)

IT IS RECOMMENDED TO SELECT THE TRANSMITTER SENSOR CODE PROVIDING THE TURNDOWN VALUE AS LOWEST AS POSSIBLE TO OPTIMIZE PERFORMANCE CHARACTERISTICS.

### Zero suppression and elevation

Zero and span can be adjusted to any value within the range limits detailed in the table as long as:

- calibrated span ≥ minimum span

### Damping

Selectable time constant : 0, 0.25, 0.5, 1, 2, 4, 8 or 16s.  
This is in addition to sensor response time

### Turn on time

Operation within specification in less than 1s with minimum damping.

### Insulation resistance

> 100MΩ at 1000VDC (terminals to earth)

## Operative limits

### Temperature limits °C (°F) :

#### Ambient (is the operating temperature)

Filling	Sensors F to P	Sensor E
Silicone oil	-40 and +85 (-40 and +185)	-25 and +85 (-13 and +185)
Inert - Galden	-20 and +85 (-4 and +185)	-10 and +85 (+14 and +185)
Inert - Halocarbon	-20 and +85 (-4 and +185)	-10 and +85 (+14 and +185)

Lower ambient limit for LCD indicators: -20°C (-4°F)

Upper ambient limit for LCD indicators: +70°C (+158°F)

Note : For Hazardous Atmosphere applications see the temperature range specified on the certificate/approval relevant to the aimed type of protection

### Process

Lower limit

- refer to lower ambient limits; -20°C (-4°F) for Viton gasket

Upper limit

- Silicone oil: 121°C (250°F) (1)
- Inert fluid: 100°C (212°F) (2)
- (1) 100°C (212°F) for application below atmospheric pressure
- (2) 65°C (150°F) for application below atmospheric pressure

### Storage

Lower limit: -50°C (-58°F); -40°C (-40°F) for LCD indicators

Upper limit: +85°C (+185°F)

### Pressure limits

#### Overpressure limits (without damage to the transmitter)

0.07kPa abs, 0.7mbar abs, 0.01psia (0.135kPa abs, 1.35mbar abs, 1mmHg for inert Galden or 0.4kPa abs, 4mbar abs, 3mmHg for inert Halocarbon) to

- 230psi for ASME CL150 flange
- 600psi for ASME CL300 flange

The pressure limit decreases with increasing temperature above 100°F (38°C), according to ASME B16.5 standards.

- 13.5bar for EN PN16 flange
- 33.8bar for EN PN40 flange

The pressure limit decreases with increasing temperature above 50°C according to EN 1092-1 standards.

### Static pressure

Transmitters for differential pressure model 264DH operates within specifications between 1.3kPa abs, 13mbar abs, 0.2psia and the flange rating specified above.

### Proof pressure

The transmitter can be exposed without leaking to line pressure of up to two times the flange rating. Meet ANSI/ISA-S 82.03 hydrostatic test requirements and SAMA PMC 27.1.

## Environmental limits

### Electromagnetic compatibility (EMC)

Comply with EN 61000-6-3 for emission and EN 61000-6-2 for immunity requirements and test;

Radiated electromagnetic immunity level: (according to IEC 1000-4-3, EN61000-4-3)	30V/m
Conducted electromagnetic immunity level : (according to IEC 1000-4-6, EN 61000-4-6)	30V
Surge immunity level (with surge protector): (according to IEC 1000-4-5 EN 61000-4-5)	4kV
Fast transient (Burst) immunity level: (according to IEC 1000-4-4 EN 61000-4-4)	4kV

### Pressure equipment directive (PED)

Comply with 97/23/EEC following sound engineering practice (SEP).

### Humidity

Relative humidity:	up to 100% annual average
Condensing, icing:	admissible

### Vibration resistance

Accelerations up to 2g at frequency up to 1000Hz  
(according to IEC 60068-2-6)

### Shock resistance

Acceleration:	50g
Duration:	11ms

(according to IEC 60068-2-27)

### Wet and dust-laden atmospheres

The transmitter is dust and sand tight and protected against immersion effects as defined by EN 60529 (1989) to IP 67 (IP 68 on request) or by NEMA to 4X or by JIS to C0920. IP65 with Harting Han connector.

## Hazardous atmospheres

With or without output meter/integral display

- COMBINED ATEX (Intrinsic safety and flameproof), FM and CSA ZELM approval. See below detailed classifications.
- COMBINED INTRINSIC SAFETY and FLAMEPROOF/EUROPE: ATEX/ZELM approval
  - II 1 GD T50°C, EEx ia IIC T6 (-40°C ≤ Ta ≤ +40°C) T95°C, EEx ia IIC T4 (-40°C ≤ Ta ≤ +85°C)
  - II 1/2 GD T85°C, EEx d IIC T6 (-40°C ≤ Ta ≤ +75°C)
- INTRINSIC SAFETY/EUROPE: ATEX/ZELM approval
  - II 1 GD T50°C, EEx ia IIC T6 (-40°C ≤ Ta ≤ +40°C) T95°C, EEx ia IIC T4 (-40°C ≤ Ta ≤ +85°C)
- TYPE "N"/EUROPE: ATEX/ZELM type examination (for HART)
  - II 3 GD T50°C, EEx nL IIC T6 (-40°C ≤ Ta ≤ +40°C) T95°C, EEx nL IIC T4 (-40°C ≤ Ta ≤ +85°C)
- FLAMEPROOF/EUROPE: ATEX/CESI approval
  - II 1/2 GD T85°C, EEx d IIC T6 (-40°C ≤ Ta ≤ +75°C)
- CANADIAN STANDARDS ASSOCIATION and FACTORY MUTUAL:
  - Explosionproof: Class I, Div. 1, Groups A, B, C, D
  - Dust ignitionproof: Class II, Div. 1, Groups E, F, G
  - Suitable for: Class II, Div. 2, Groups F, G; Class III, Div. 1, 2
  - Nonincendive: Class I, Div. 2, Groups A, B, C, D
  - Intrinsically safe: Class I, II, III, Div. 1, Groups A, B, C, D, E, F, G AEx ia IIC T6/T4, Zone 0 (FM)
- STANDARDS AUSTRALIA (SAA): TS Approval
  - Intrinsically safe Ex ia IIC T4/T5 (-20°C ≤ Ta ≤ +80°C) only HART
  - No sparking Ex n IIC T4/T6 (-20°C ≤ Ta ≤ +80°C) only HART
  - Flameproof Ex d IIC T4/T6 (-20°C ≤ Ta ≤ +80°C)
  - Dust ignitionproof DIP A21 Ta T6 (-20°C ≤ Ta ≤ +80°C)
- INTRINSIC SAFETY/CHINA NEPSI approval Ex ia IIC T4-T6
- FLAMEPROOF/CHINA NEPSI approval Ex d IIC T6
- GOST (Russia), GOST (Kazakistan), Inmetro (Brazil) based on ATEX

## Electrical Characteristics and Options

### HART digital communication and 4 to 20mA output

#### Power Supply

The transmitter operates from 10.5 to 42VDC with no load and is protected against reverse polarity connection (additional load allows operations over 42VDC).

For EEx ia and other intrinsically safe approval power supply must not exceed 30VDC.

#### Ripple

20mV max on a 250Ω load as per HART specifications

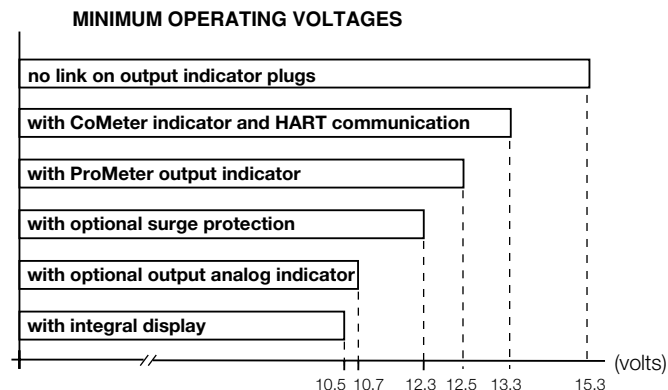

#### Load limitations

4 to 20mA and HART total loop resistance :

$$R(k\Omega) = \frac{\text{Supply voltage} - \text{min. operating voltage (VDC)}}{22.5}$$

A minimum of 250Ω is required for HART communication.

### Optional indicators

#### Output meter

CoMeter and Prometer LCD :

5-digit ( $\pm 99999$  counts) programmable with 7.6mm. high (3in), 7-segment numeric characters plus sign and digital point for digital indication of output value in percentage, current or engineer unit;

10-segment bargraph display (10% per segment) for analog indication of output in percentage;

7-digit with 6mm. high (2.3in), 14-segment alphanumeric characters, for engineer units and configuration display

Analog : 36mm (1.4in) scale on 90°.

#### Integral display

LCD, 15 lines x 56 column dot matrix providing 2 lines indication as

- top: 5-digit (numeric) plus sign or 7-digit alphanumeric
- bottom: 7-digit alphanumeric

and additional 50-segment bargraph for indication of analog output in percentage.

User-definable matrix display mode with HART communication:

- process variable in pressure unit or
- output signal as percentage, current or engineering units

Display also indicates in/out transfer function, static pressure, sensor temperature and diagnostic messages and provides configuration facilities.

#### Optional surge protection

Up to 4kV

- voltage 1.2 μs rise time / 50 μs delay time to half value
- current 8 μs rise time / 20 μs delay time to half value

#### Output signal

Two-wire 4 to 20mA, user-selectable for linear or square root output, power of  $3/2$  or  $5/2$ , 5th order or two 2nd order switching point selectable programmable polynomial output.

HART® communication provides digital process variable (% , mA or engineering units) superimposed on 4 to 20mA signal, with protocol based on Bell 202 FSK standard.

#### Output current limits (to NAMUR standard)

Overload condition

- Lower limit: 3.8mA
- Upper limit: 20.5mA

#### Transmitter failure mode (to NAMUR standard)

The output signal can be user-selected to a value of 3.7 or 22mA on gross transmitter failure condition, detected by self-diagnostics.

In case of CPU failure the output is driven <3.7mA or >22mA.

## PROFIBUS PA output

### Device type

Pressure transmitter compliant to Profiles 3.0 Class A & B; ident. number 052B HEX.

### Power supply

The transmitter operates from 9 to 32VDC , polarity independent.

For EEx ia approval power supply must not exceed 17.5VDC. Intrinsic safety installation according to FISCO model.

### Current consumption

operating (quiescent): 10.5mA

fault current limiting: 20mA max.

### Output signal

Physical layer in compliance to IEC 1158-2/EN 61158-2 with transmission to Manchester II modulation, at 31.25kbit/sec.

### Output interface

PROFIBUS PA communication according to Profibus DP50170 Part 2/ DIN 19245 part 1-3.

### Output update time

25ms

### Function blocks

2 analog input, 1 transducer, 1 physical

### Integral display

LCD, 15 lines x 56 column dot matrix providing 2 lines indication as

– top: 5-digit (numeric) plus sign or 7-digit alphanumeric

– bottom: 7-digit alphanumeric

and additional 50-segment bargraph for indication of output in percentage of the analog input function block assigned to the primary variable.

User-definable matrix display mode:

– process variable in pressure units or

– primary variable in engineering units (output of transducer block) or

– output as percentage or engineering units of analog input function blocks

Display also indicates diagnostic messages and provides configuration facilities.

Secondary variable, static pressure and sensor temperature can be read.

### Transmitter failure mode

On gross transmitter failure condition, detected by self-diagnostics, the output signal can be driven to defined conditions, selectable by the user as safe, last valid or calculated value. If electronic failure or short circuit occur the transmitter consumption is electronically limited at a defined value (20mA approx), for safety of the network.

## FOUNDATION Fieldbus output

### Device type

LINK MASTER DEVICE

Link Active Scheduler (LAS) capability implemented.

### Power supply

The transmitter operates from 9 to 32VDC, polarity independent.

For EEx ia approval power supply must not exceed 24VDC (entity certification) or 17.5VDC (FISCO certification), according to FF-816.

### Current consumption

operating (quiescent): 10.5mA

fault current limiting: 20mA max.

### Output signal

Physical layer in compliance to IEC 1158-2/EN 61158-2 with transmission to Manchester II modulation, at 31.25kbit/sec.

### Function blocks/execution period

2 enhanced Analog Input blocks/25ms max (each)

1 enhanced PID block/40ms max.

1 standard ARithmetic block/25ms

1 standard Input Selector block/25ms

1 standard Control Selector block/25ms

1 standard Signal Characterization block/25ms

1 standard Integrator/Totalizer block/25ms

### Additional blocks

1 enhanced Resource block

1 custom Pressure with calibration transducer block

1 custom Advanced Diagnostics transducer block including Plugged Input Line Detection

1 custom Local Display transducer block

### Number of link objects

35

### Number of VCRs

35

### Output interface

FOUNDATION fieldbus digital communication protocol to standard H1, compliant to specification V. 1.6; FF registration in progress.

### Integral display

LCD, 15 lines x 56 column dot matrix providing 2 lines indication as

– top: 5-digit (numeric) plus sign or 7-digit alphanumeric

– bottom: 7-digit alphanumeric

and additional 50-segment bargraph for percentage indication of the analog input function block output, assigned to the primary variable.

User-definable matrix display mode:

– process variable in pressure units or

– primary variable in engineering units (output of transducer block) or

– output as percentage or engineering units of one or more selected function blocks

Display also indicates diagnostic messages. Secondary variable, static pressure and sensor temperature can be read.

### Transmitter failure mode

The output signal is "frozen" to the last valid value on gross transmitter failure condition, detected by self-diagnostics which also indicate a BAD conditions. If electronic failure or short circuit occur the transmitter consumption is electronically limited at a defined value (20mA approx), for safety of the network.

## Performance specifications

Stated at reference condition to IEC 60770 ambient temperature of 20°C (68°F), relative humidity of 65%, atmospheric pressure of 1013hPa (1013mbar), mounting position with vertical diaphragm and zero based range for transmitter with isolating diaphragms in AISI 316 L ss or Hastelloy and silicone oil fill and HART digital trim values equal to 4–20mA span end points, in linear mode.

Unless otherwise specified, errors are quoted as % of span.

Some performance data are affected by the actual turndown (TD) as ratio between Upper Range Limit (URL) and calibrated span.

IT IS RECOMMENDED TO SELECT THE TRANSMITTER SENSOR CODE PROVIDING THE TURNDOWN VALUE AS LOWEST AS POSSIBLE TO OPTIMIZE PERFORMANCE CHARACTERISTICS.

### Dynamic performance (according to IEC 61298–1 definition)

Dead time: 40ms

Time constant (63.2% of total step change):

– sensors M and P: ≤ 70ms

– sensor H: 100ms

– sensor G: 130ms

– sensor F: 180ms

Response time (total) = dead time + time constant

## Accuracy rating

% of calibrated span, including combined effects of terminal based linearity, hysteresis and repeatability.

For fieldbus versions SPAN refer to analog input function block outscale range

– ±0.075% for TD from 1:1 to 15:1

– ±0.005% ×  $\frac{\text{URL}}{\text{Span}}$  for TD from 15:1 to 60:1  
(30:1 for sensor code E)

## Operating influences

### Ambient temperature

per 20K (36°F) change between the limits of –20°C to +65°C (–4 to +150°F) :

Model	Sensor Code	for TD up to	
264DH	E to P	15:1	± (0.04% URL + 0.065% span)

### Optional CoMeter and ProMeter ambient temperature

Total reading error per 20K (36°F) change between the ambient limits of –20 and +70°C (–4 and +158°F) :

±0.15% of max span (16mA).

### Static pressure (zero errors can be calibrated out at line pressure)

per 2MPa, 20bar or 290psi

#### Model 264DH

– zero error: ±0.10% of URL

– span error: ±0.10% of reading

Multiply by 1.5 the errors for sensor code E.

### Supply voltage

Within voltage/load specified limits the total effect is less than 0.005% of URL per volt.

### Load

Within load/voltage specified limits the total effect is negligible.

### Electromagnetic field

Total effect : less than 0.10% of span from 20 to 1000MHz and for field strengths up to 30V/m when tested with shielded conduit and grounding, with or without meter.

### Common mode interference

No effect from 100Vrms @ 50Hz, or 50VDC

### Mounting position

Rotations in plane of diaphragm have negligible effect. A tilt to 90° from vertical causes a zero shifts up to 0.5kPa, 5mbar or 2inH<sub>2</sub>O, which can be corrected with the zero adjustment. No span effect.

### Stability

±0.15% of URL over a five years period

### Vibration effect

±0.10% of URL (according to IEC 61298–3)

## Physical Specification

(Refer to ordering information sheets for variant availability related to specific model or versions code)

### Materials

#### Process isolating diaphragms (\*)

AISI 316 L ss; Hastelloy C276™; Monel 400™; Tantalum;

Hastelloy C276™ on AISI 316 L ss gasket seat.

#### High pressure side process mounting flange

AISI 316 L ss with flushing connection

#### Low pressure side process flanges, adapters, plugs and drain/vent valves (\*)

AISI 316 L ss; Hastelloy C276™; Monel 400™.

#### Sensor fill fluid

Silicone oil (DC200™); inert fill (Halocarbon™ 4.2 or Galden™).

#### Gaskets (\*)

Viton™; PTFE.

#### Sensor housing

AISI 316 L ss.

#### Bolts and nuts

AISI 316 ss bolts and nuts Class A4–50 per UNI 7323 (ISO 3506), in compliance with NACE MR0175 Class II.

#### Electronic housing and covers

Barrel version

- Aluminium alloy with baked epoxy finish;
- Copper-free content aluminium alloy with baked epoxy finish;
- AISI 316 L ss.

DIN version

- Aluminium alloy with baked epoxy finish.

#### Covers O-ring

Buna N.

#### Local zero and span adjustments:

Glass filled polycarbonate plastic (removable).

#### Tagging

AISI 316ss data plate attached to the electronics housing.

#### Calibration

Standard: at maximum span, zero based range, ambient temperature and pressure;

Optional: at specified range and ambient conditions.

## Optional extras

### Output indicator

plug-in rotatable type, LCD or analog.

### Supplemental customer tag

AISI 316 ss tag screwed/fastened to the transmitter for customer's tag data up to a maximum of 20 characters and spaces on one line for tag number and tag name, and up to a maximum of 3 spaced strings of 10 characters each for calibration details (lower and upper values plus unit). Special typing evaluated on request for charges.

### Surge protection (only as external unit for PROFIBUS PA and FF)

### Cleaning procedure for oxygen service

### Hydrogen or special service preparation

### Test Certificates (test, design, calibration, material traceability)

### Tag and manual language

### Communication connectors

### Process connections

Low pressure side

- on flange : 1/4 – 18 NPT on process axis
- on adapter : 1/2 – 14 NPT on process axis
- fixing threads: 7/16 – 20 UNF at 41.3mm centre distance

High pressure side (\*\*):

2in or 3in, ASME150 or 300RF  
DN50 or DN80, PN16 or 40 to EN 1092-1 Type B1

### Electrical connections

Two 1/2 – 14 NPT or M20x1.5 or PG 13.5 or 1/2 GK threaded conduit entries, direct on housing.

Special communication connector (on request)

- HART : straight or angle Harting Han connector and one plug.
- FOUNDATION Fieldbus, PROFIBUS PA: M12x1 or 7/8.

### Terminal block

HART version: three terminals for signal/external meter wiring up to 2.5mm<sup>2</sup> (14AWG) and three connection points for test and communication purposes.

Fieldbus versions: two terminals for signal wiring (bus connection) up to 2.5mm<sup>2</sup> (14AWG)

### Grounding

Internal and external 6mm<sup>2</sup> (10AWG) ground termination points are provided.

### Mounting position

Transmitter can be mounted in any position.

Electronics housing may be rotated to any position (not with DIN housing). A positive stop prevents over travel.

### Mass (without options)

7 to 11kg approx (16 to 24lb); add 1.5kg (3.4lb) for AISI housing.  
Add 650g (1.5lb) for packing.

### Packing

Carton 35 x 33 x 35cm approx (14 x 13 x 14in).

™ Hastelloy is a Cabot Corporation trademark

™ Monel is an International Nickel Co. trademark

™ Galden is a Montefluos trademark

™ Viton is a Dupont de Nemour trademark

™ Halocarbon is a Halocarbon Products Co. trademark

™ DC 200 is a Dow Corning Corporation trademark

(\*) Wetted parts of the transmitter.

(\*\*) Bolts and nuts, gasket and mating flange supplied by customer.

## Configuration

### Transmitter with HART communication and 4 to 20 mA

#### Standard configuration

Transmitters are factory calibrated to customer's specified range. Calibrated range and tag number are stamped on the tag plate. If a calibration range and tag data are not specified, the transmitter will be supplied with the plate left blank and configured as follows:

Engineering Unit	kPa
4 mA	Zero
20 mA	Upper Range Limit (URL)
Output	Linear
Damping	1 sec.
Transmitter failure mode	Upscale
Software tag (8 characters max)	Blank
Optional LCD indicator/display	0 to 100.0% linear

Any or all the above configurable parameters, including Lower range-value and Upper range-value which must be the same unit of measure, can be easily changed using the HART hand-held communicator or by a PC running the configuration software SMART VISION with DTM for 2600T. The transmitter database is customized with specified flange type and material, O-ring and drain/vent materials and meter code option.

#### Custom configuration (option)

The following data may be specified in addition to the standard configuration parameters:

Descriptor	16 alphanumeric characters
Message	32 alphanumeric characters
Date	Day, month, year

### Transmitter with PROFIBUS PA communication

Transmitters are factory calibrated to customer's specified range. Calibrated range and tag number are stamped on the tag plate. If a calibration range and tag data are not specified, the transmitter will be supplied with the plate left blank and configured as follows:

Measure Profile	Pressure
Engineering Unit	kPa
Output scale 0%	Lower Range Limit (LRL)
Output scale 100%	Upper Range Limit (URL)
Output	Linear
Hi-Hi Limit	Upper Range Limit (URL)
Hi Limit	Upper Range Limit (URL)
Low Limit	Lower Range Limit (LRL)
Low-Low Limit	Lower Range Limit (LRL)
Limits hysteresis	0.5% of output scale
PV filter	0 sec.
Address (settable by local key)	126
Tag	32 alphanumeric characters

Any or all the above configurable parameters, including Lower range-value and Upper range-value which must be the same unit of measure, can be easily changed by a PC running the configuration software SMART VISION with DTM for 2600T. The transmitter database is customized with specified flange type and material, O-ring and drain/vent materials and meter code option.

#### Custom configuration (option)

The following data may be specified in addition to the standard configuration parameters:

Descriptor	32 alphanumeric characters
Message	32 alphanumeric characters
Date	Day, month, year

### Transmitter with FOUNDATION Fieldbus communication

Transmitters are factory calibrated to customer's specified range. Calibrated range and tag number are stamped on the tag plate. If a calibration range and tag data are not specified, the transmitter will be supplied with the plate left blank and the analog input function block FB1 is configured as follows:

Measure Profile	Pressure
Engineering Unit	kPa
Output scale 0%	Lower Range Limit (LRL)
Output scale 100%	Upper Range Limit (URL)
Output	Linear
Hi-Hi Limit	Upper Range Limit (URL)
Hi Limit :	Upper Range Limit (URL)
Low Limit	Lower Range Limit (LRL)
Low-Low Limit	Lower Range Limit (LRL)
Limits hysteresis	0.5% of output scale
PV filter time	0 sec.
Tag	32 alphanumeric characters

The analog input function block FB2 is configured for the sensor temperature measured in °C. Any or all the above configurable parameters, including the range values, can be changed using any host compliant to FOUNDATION fieldbus. The transmitter database is customized with specified flange type and material, O-ring and drain/vent materials and meter code option.

For any protocol available engineering units of pressure measure are :

Pa, kPa, MPa  
 inH<sub>2</sub>O@4°C, mmH<sub>2</sub>O@4°C, psi  
 inH<sub>2</sub>O@20°C, ftH<sub>2</sub>O@20°C, mmH<sub>2</sub>O@20°C  
 inHg, mmHg, Torr  
 g/cm<sup>2</sup>, kg/cm<sup>2</sup>, atm  
 mbar, bar

**MOUNTING DIMENSIONS** (not for construction unless certified) – dimensions in mm (in)

**Transmitter with barrel aluminium housing**

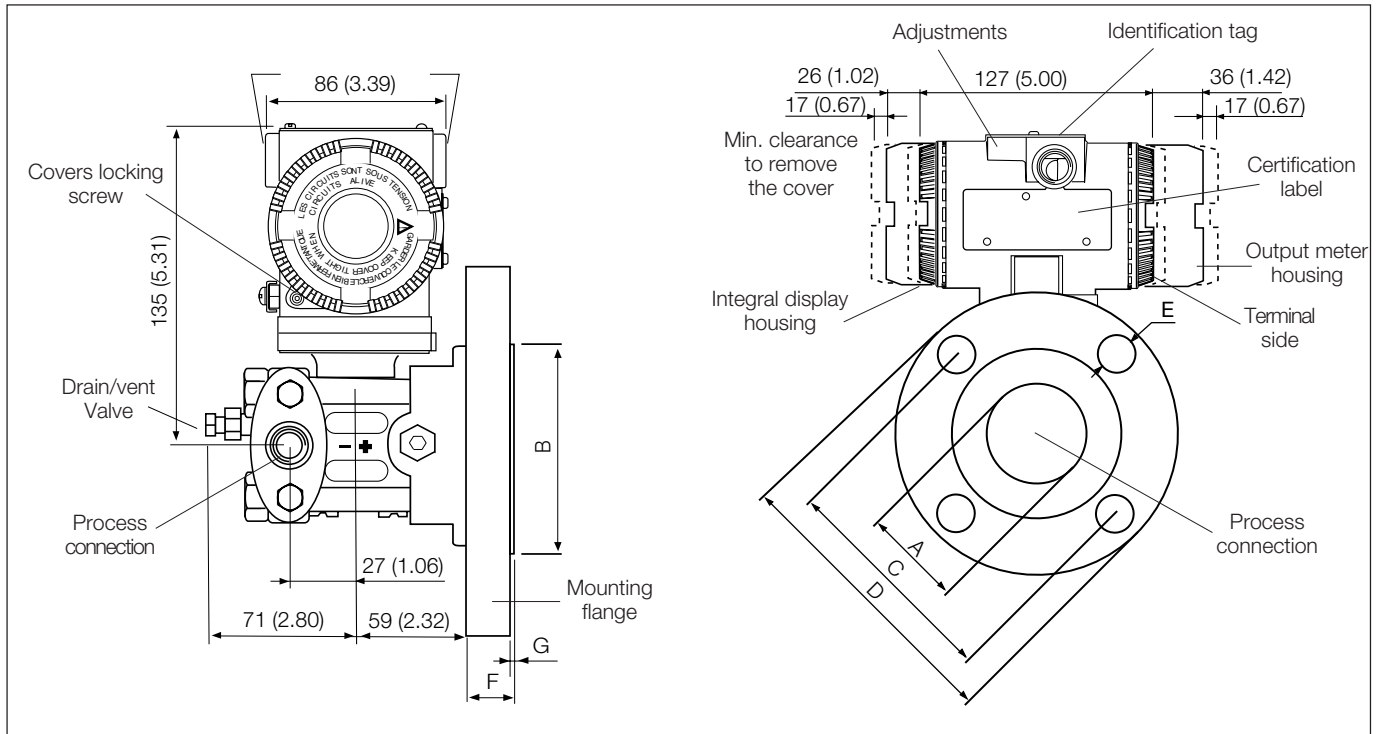

NOTE : Process connection, gasket groove and gaskets on low pressure side are in accordance with DIN 19213. Bolting threads for fixing adapter or other devices (i.e. manifold etc.) on process flange is  $\frac{7}{16}$  – 20 UNF.

Rating	Size	Dimensions mm (in)							N° of holes
		A (dia)	B (dia)	C (dia)	D (dia)	E (dia)	F	G	
ASME 150 R.F.	2in	53 (2.09)	92 (3.62)	120.5 (4.74)	152.5 (6)	20 (0.79)	19.5 (0.77)	1.6 (0.07)	4
ASME 150 R.F.	3in	77 (3.04)	127 (5)	152.5 (6)	190.5 (7.5)	20 (0.79)	24 (0.94)	1.6 (0.07)	4
ASME 300 R.F.	2in	53 (2.09)	92 (3.62)	127 (5)	165 (6.5)	20 (0.79)	22.5 (0.89)	1.6 (0.07)	8
ASME 300 R.F.	3in	77 (3.04)	127 (5)	168.5 (6.63)	210 (8.26)	22 (0.86)	28.5 (1.12)	1.6 (0.07)	8
EN PN 16 Type B1	DN50	53 (2.09)	102 (4.02)	125 (4.92)	165 (6.5)	18 (0.71)	20 (0.79)	3 (0.12)	4
EN PN 16 Type B1	DN80	77 (3.04)	138 (5.43)	160 (6.3)	200 (7.87)	18 (0.71)	20 (0.79)	2 (0.08)	8
EN PN 40 Type B1	DN50	53 (2.09)	102 (4.02)	125 (4.92)	165 (6.5)	18 (0.71)	20 (0.79)	3 (0.12)	4
EN PN 40 Type B1	DN80	77 (3.04)	138 (5.43)	160 (6.3)	200 (7.87)	18 (0.71)	24 (0.94)	2 (0.08)	8

Transmitter with DIN aluminium housing

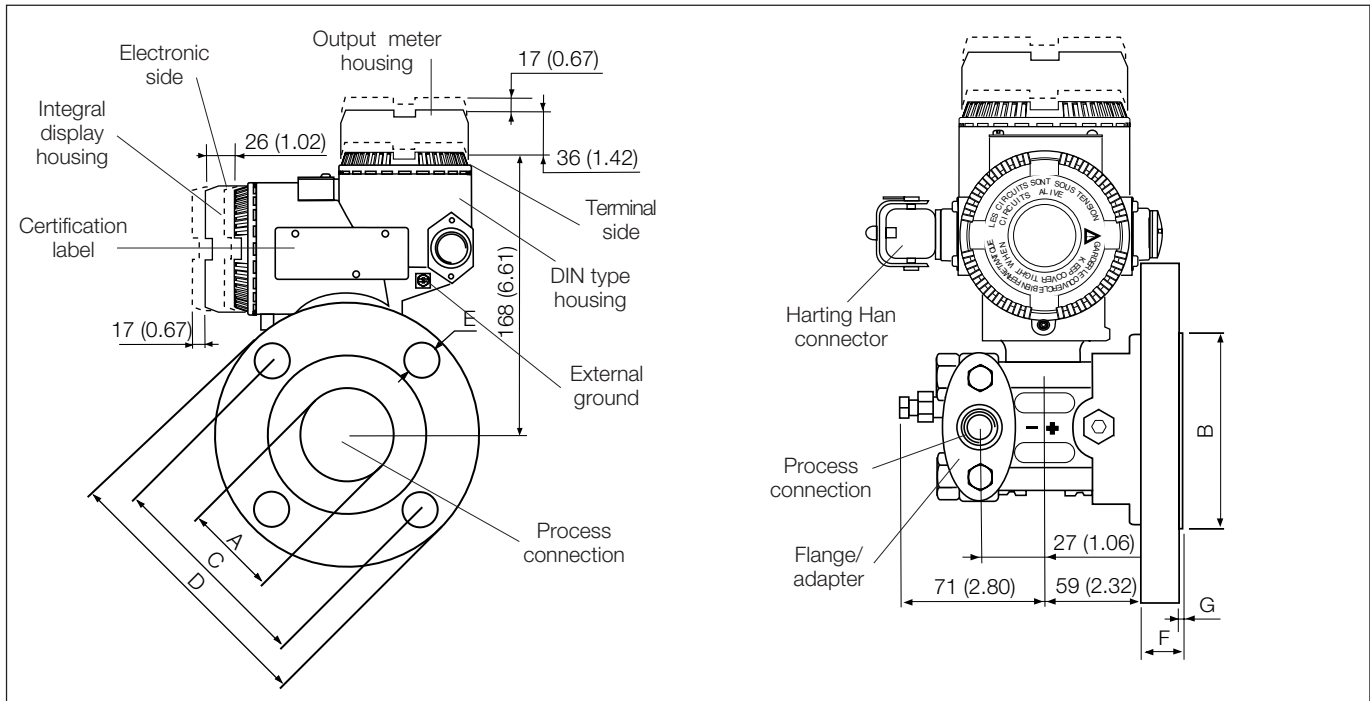

**Electrical connections**  
**HART Version**

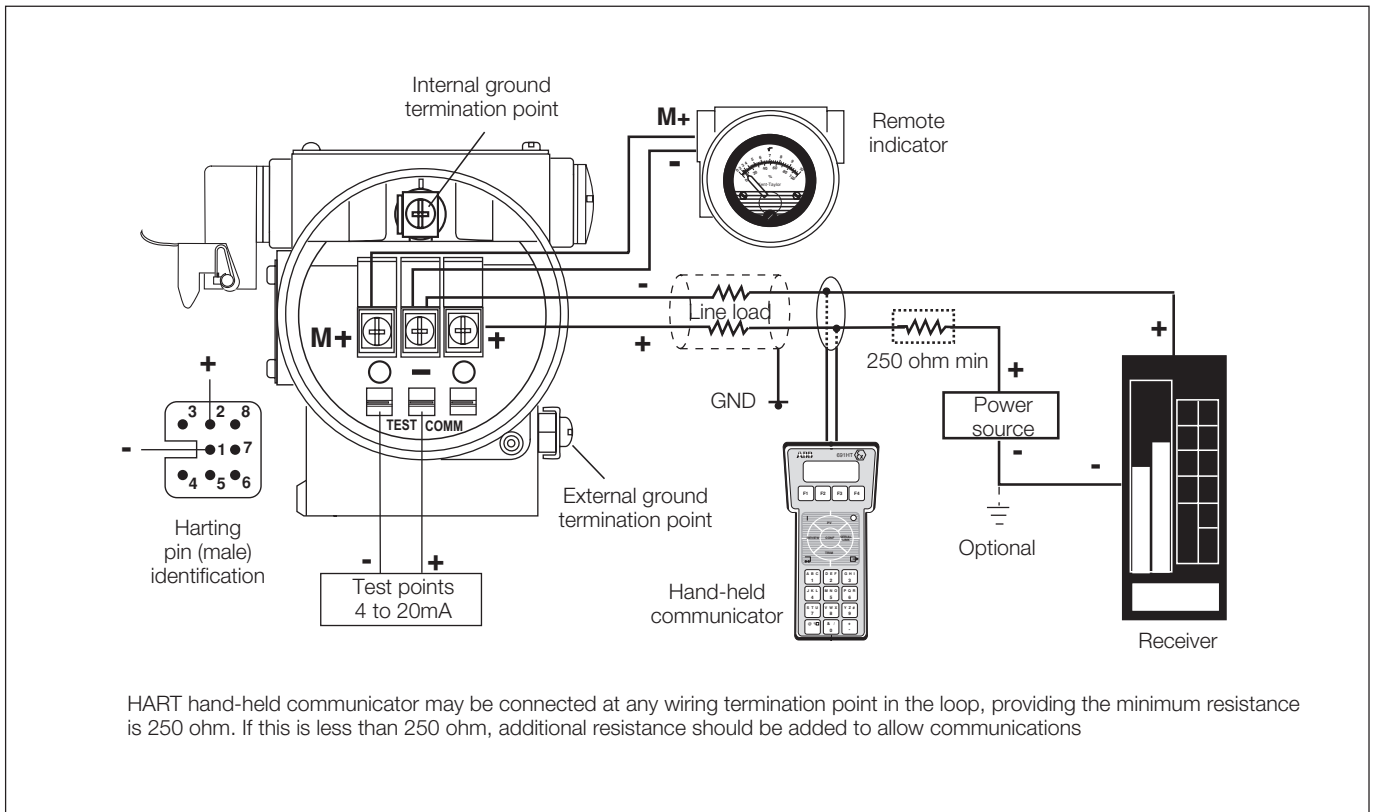

**FIELDBUS Versions**

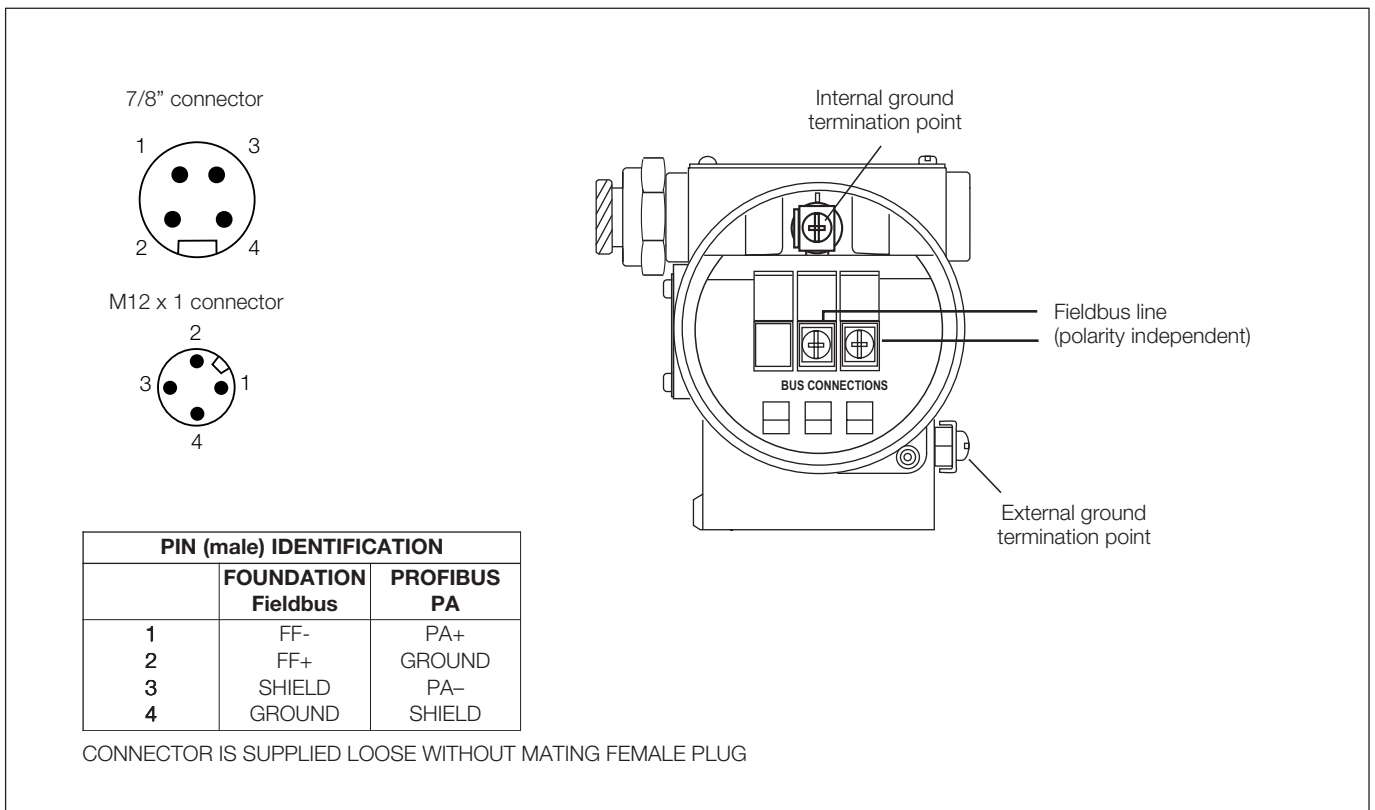

**BASIC ORDERING INFORMATION model 264DH Flange Mounted Differential Pressure Transmitter**

Select one character or set of characters from each category and specify complete catalog number.  
Refer to additional ordering information code and specify one or more codes for each transmitter if additional options are required.

BASE MODEL – 1 <sup>st</sup> to 5 <sup>th</sup> characters			2	6	4	D	H	X	X	X	X	X	X	X
Flange Mounted Differential Pressure Transmitter – BASE ACCURACY 0.075%														
<b>SENSOR - Span limits – 6<sup>th</sup> character</b>														
0.27 and 16kPa	2.7 and 160mbar	1.08 and 64inH <sub>2</sub> O						E						
0.4 and 40kPa	4 and 400mbar	1.6 and 160inH <sub>2</sub> O						F						
0.65 and 65kPa	6.5 and 650mbar	2.6 and 260inH <sub>2</sub> O						G						
1.6 and 160kPa	16 and 1600mbar	6.4 and 642inH <sub>2</sub> O						H						
6 and 600kPa	0.06 and 6bar	0.87 and 87psi						M						
24 and 2400kPa	0.24 and 24bar	3.5 and 348psi						P						
<b>HIGH PRESSURE SIDE - Process mounting flange size/rating – 7<sup>th</sup> character</b>														
2in	ASME CL150								A					
2in	ASME CL300								D					
3in	ASME CL150								B					
3in	ASME CL300								E					
DN50	EN PN16/40								M					
DN80	EN PN16								N					
DN80	EN PN40								L					
<b>HIGH PRESSURE SIDE - Mounting flange material/seat form – 8<sup>th</sup> character</b>														
AISI 316L ss	Form RF (raised face) - serrated finish	(Note 2)								D				
AISI 316L ss	EN 1092-1 Type B1 - serrated finish	(Note 3)								L				
<b>Diaphragm material / Fill fluid (wetted parts) – 9<sup>th</sup> character</b>														
AISI 316 L ss	Silicone oil											S		
Hastelloy C276™ (on AISI seat)	Silicone oil							NACE				H		
Hastelloy C276™	Silicone oil							NACE				K		
Monel 400™	Silicone oil							NACE				M		
Tantalum	Silicone oil							NACE				T		
AISI 316 L ss	Inert fluid - Galden	(Note 1)										A		
Hastelloy C276™ (on AISI seat)	Inert fluid - Galden	(Note 1)						NACE				B		
Hastelloy C276™	Inert fluid - Galden	(Note 1)						NACE				F		
Monel 400™	Inert fluid - Galden	(Note 1)						NACE				C		
Tantalum	Inert fluid - Galden	(Note 1)						NACE				D		
AISI 316 L ss	Inert fluid - Halocarbon	(Note 1)										L		
Hastelloy C276™ (on AISI seat)	Inert fluid - Halocarbon	(Note 1)						NACE				Q		
Hastelloy C276™	Inert fluid - Halocarbon	(Note 1)						NACE				P		
Monel 400™	Inert fluid - Halocarbon	(Note 1)						NACE				4		
Tantalum	Inert fluid - Halocarbon	(Note 1)						NACE				5		
<b>Low side process flanges/adapters material and connection (wetted parts) – 10<sup>th</sup> character</b>														
AISI 316 L ss (Horizontal connection)	1/4 – 18 NPT-f direct (7/16 – 20 UNF U.S. drilling)							NACE					A	
AISI 316 L ss (Horizontal connection)	1/2 – 14 NPT-f through adapter (7/16 – 20 UNF U.S. drilling)							NACE					B	
Hastelloy C276™ (Horizontal connection)	1/4 – 18 NPT-f direct (7/16 – 20 UNF U.S. drilling)	(Note 4)						NACE					D	
Hastelloy C276™ (Horizontal connection)	1/2 – 14 NPT-f through adapter (7/16 – 20 UNF U.S. drilling)	(Note 4)						NACE					E	
Monel 400™ (Horizontal connection)	1/4 – 18 NPT-f direct (7/16 – 20 UNF U.S. drilling)	(Note 4)						NACE					G	
Monel 400™ (Horizontal connection)	1/2 – 14 NPT-f through adapter (7/16 – 20 UNF U.S. drilling)	(Note 4)						NACE					H	
<b>Bolts/Gasket (wetted parts) – 11<sup>th</sup> character</b>														
AISI 316 ss (NACE) – (MWP = 16MPa)	Viton™							NACE						3
AISI 316 ss (NACE) – (MWP = 16MPa)	PTFE	(Note 1)						NACE						4
<b>Housing material and electrical connection – 12<sup>th</sup> character</b>														
Aluminium alloy (Barrel version)	1/2 – 14 NPT													A
Aluminium alloy (Barrel version)	M20 x 1.5 (CM 20)													B
Aluminium alloy (Barrel version)	Pg 13.5													D
Aluminium alloy (Barrel version)	1/2 GK													C
Aluminium alloy (Barrel version)	Harting Han connector	(general purpose only)							(Note 5)					E
Aluminium alloy (Barrel version)	Fieldbus connector	(general purpose only)							(Note 5)					G
Aluminium alloy copper-free (Barrel version)	1/2 – 14 NPT													H
Aluminium alloy copper-free (Barrel version)	M20 x 1.5 (CM 20)													L
Aluminium alloy copper-free (Barrel version)	Pg 13.5													N
Aluminium alloy copper-free (Barrel version)	1/2 GK													M
Aluminium alloy copper-free (Barrel version)	Harting Han connector	(general purpose only)							(Note 5)					P
Aluminium alloy copper-free (Barrel version)	Fieldbus connector	(general purpose only)							(Note 5)					R
AISI 316 L ss (Barrel version)	1/2 – 14 NPT													S
AISI 316 L ss (Barrel version)	M20 x 1.5 (CM20)													T
AISI 316 L ss (Barrel version)	Pg 13.5													V
AISI 316 L ss (Barrel version)	1/2 GK													U
AISI 316 L ss (Barrel version)	Fieldbus connector	(general purpose only)							(Note 5)					Z
Aluminium alloy (DIN version)	M20 x 1.5 (CM 20)	(general purpose only)												J
Aluminium alloy (DIN version)	Pg 13.5	(general purpose only)												Y
Aluminium alloy (DIN version)	Harting Han connector	(general purpose only)							(Note 5)					K
<b>Output/Additional options – 13<sup>th</sup> character</b>														
HART digital communication and 4 to 20mA	No additional options	(Notes 6, 7)												H
HART digital communication and 4 to 20mA	Options requested (to be ordered by "Additional ordering code")	(Note 6)												1
PROFIBUS PA	No additional options	(Notes 6, 7)												P
PROFIBUS PA	Options requested (to be ordered by "Additional ordering code")	(Note 7)												2
FOUNDATION Fieldbus	No additional options	(Notes 6, 7)												F
FOUNDATION Fieldbus	Options requested (to be ordered by "Additional ordering code")	(Note 7)												3

**ADDITIONAL ORDERING INFORMATION for model 264DH**

Add one or more 2-digit code(s) after the basic ordering information to select all required options

	XX	XX	XX	XX	XX	XX	XX	XX	XX	XX	Cont'd
<b>Drain/vent valve (material and position) (wetted parts)</b>											
AISI 316 L ss on process axis (Note 8)	NACE	V1									
AISI 316 L ss on flange side top (Note 8)	NACE	V2									
AISI 316 L ss on flange side bottom (Note 8)	NACE	V3									
Hastelloy C276™ on process axis (Note 9)	NACE	V4									
Hastelloy C276™ on flange side top (Note 9)	NACE	V5									
Hastelloy C276™ on flange side bottom (Note 9)	NACE	V6									
Monel 400™ on process axis (Note 10)	NACE	V7									
Monel 400™ on flange side top (Note 10)	NACE	V8									
Monel 400™ on flange side bottom (Note 10)	NACE	V9									
<b>Electrical certification</b>											
ATEX Group II Category 1 GD – Intrinsic Safety EEx ia		E1									
ATEX Group II Category 1/2 GD – Flameproof EEx d		E2									
ATEX Group II Category 3 GD – Type of protection "N" EEx nL design compliance (Note 11)		E3									
Canadian Standard Association (CSA) (only 1/2–14NPT, M20 and Pg 13.5 electrical connection)		E4									
Standards Australia SAA (Not Ex ia and Ex n for PROFIBUS PA and FOUNDATION Fieldbus)		E5									
Factory Mutual (FM) approval (only with 1/2–14NPT, M20 and Pg 13.5 electrical connection)		E6									
Combined ATEX - Intrinsic Safety and Flameproof		E7									
Combined ATEX, FM and CSA (only with 1/2–14NPT, M20 and Pg 13.5 electrical connection) (Note 11)		EN									
NEPSI (China) - Intrinsic Safety Ex ia		EY									
NEPSI (China) - Flameproof Ex d		EZ									
GOST (Russia) EEx ia		W1									
GOST (Russia) EEx d		W2									
GOST (Kazakistan) EEx ia		W3									
GOST (Kazakistan) EEx d		W4									
Inmetro (Brazil) EEx ia (Note 11)		W5									
Inmetro (Brazil) EEx d (Note 11)		W6									
Inmetro (Brazil) EEx nL (Note 11)		W7									
<b>Output meter</b>											
ProMeter, Standard calibration (Note 11)		D1									
ProMeter, Special calibration (Note 11)		D2									
Analog output indicator linear 0–100% scale (Note 11)		D3									
Analog output indicator square root 0–10 scale (Note 11)		D4									
Analog output indicator, special graduation (to be specified for linear scale) (Note 11)		D5									
Analog output indicator, special graduation (to be specified for square root scale) (Note 11)		D6									
Programmable signal meter and HART configurator (CoMeter) (Note 11)		D7									
Programmable signal meter and HART configurator (CoMeter – customer configuration) (Note 11)		D8									
<b>Integral LCD</b>											
Digital LCD integral display									L1		
<b>Surge</b>											
Surge/Transient Protector (Internal for HART / 4-20mA)											
Surge/Transient Protector (External supplied loose for PROFIBUS PA and FOUNDATION Fieldbus only suitable with 1/2–14NPT and M20 electrical connection and with ATEX, FM and CSA certifications, no DUST)									S1		
<b>Operating manual</b>											
German										M1	
Italian										M2	
Spanish										M3	
French										M4	
<b>Labels &amp; tag language</b>											
German											T1
Italian											T2
Spanish											T3
French											T4
<b>Additional tag plate</b>											
Laser printing of tag on stainless steel plate											I2
<b>Configuration</b>											
Standard – Pressure = inH <sub>2</sub> O/psi at 20° C; Temperature = deg. F											N2
Standard – Pressure = inH <sub>2</sub> O/psi at 4° C; Temperature = deg. F											N3
Standard – Pressure = inH <sub>2</sub> O/psi at 20° C; Temperature = deg.C											N4
Standard – Pressure = inH <sub>2</sub> O/psi at 4° C; Temperature = deg. C											N5
Custom											N6
<b>Preparation procedure</b>											
Oxygen service cleaning (only available with inert fill and PTFE gasket) – P <sub>max</sub> = 12MPa for Galden or 9MPa for Halocarbon; T <sub>max</sub> = 60° C/140° F											P1
Hydrogen service preparation											P2
Special services preparation											P4

## 2600T Pressure Transmitters

Model 264DH

SS/264DH\_5

ADDITIONAL ORDERING INFORMATION for model 264DH		XX	XX	XX
<b>Certificates</b>				
Inspection certificate EN 10204–3.1 of calibration (9-point)		C1		
Certificate of compliance with the order EN 10204–2.1 of instrument design		C6		
<b>Material traceability</b>				
Certificate of compliance with the order EN 10204–2.1 of process wetted parts			H1	
Inspection certificate EN 10204–3.1 of process wetted parts			H3	
<b>Connector</b>				
Fieldbus 7/8 (Recommended for FOUNDATION Fieldbus) - (supplied loose without mating female plug)	(Notes 6, 12)			U1
Fieldbus M12x1 (Recommended for PROFIBUS PA) - (supplied loose without mating female plug)	(Notes 6, 12)			U2
Harting Han – straight entry	(Notes 5, 12)			U3
Harting Han – angle entry	(Notes 5, 12)			U4

Note 1: Suitable for oxygen service

Note 2: Not available with DIN mounting flange code M, N, L

Note 3: Not available with ASME mounting flange code A, D, B, E

Note 4: Not available with diaphragm material/fill fluid code S, H, A, B, L, Q

Note 5: Select type in additional ordering code

Note 6: Not available with Electronic Housing code Z, R, G

Note 7: Not available with Electronic Housing code P, E and K

Note 8: Not available with Process flanges/adapters code D, E, G, H

Note 9: Not available with Process flanges/adapters code A, B, G, H

Note 10: Not available with Process flanges/adapters code A, B, D, E

Note 11: Not available with PROFIBUS PA and FF output code 2 or 3

Note 12: Not available with Electronic housing code U, S, T, V, H, M, L, N, D, C, A, B, J, Y

™ Hastelloy is a Cabot Corporation trademark

™ Monel is an International Nickel Co. trademark

™ Viton is a Dupont de Nemour trademark

™ Galden is a Montefluos trademark

™ Halocarbon is a Halocarbon Products Co. trademark

### Standard delivery items (can be differently specified by additional ordering code)

- Adapters supplied loose
- Plug on axis (no drain/vent valves)
- General purpose (no electrical certification)
- No meter/display, no mounting bracket, no surge protection
- English manual and labels
- Configuration with kPa and deg. C units
- No test, inspection or material traceability certificates

THE SELECTION OF SUITABLE WETTED PARTS AND FILLING FLUID FOR COMPATIBILITY WITH THE PROCESS MEDIA IS A CUSTOMER'S RESPONSIBILITY, IF NOT OTHERWISE NOTIFIED BEFORE MANUFACTURING.



## 2600T Pressure Transmitters

Model 264DH

---

ABB has Sales & Customer Support expertise in over 100 countries worldwide

[www.abb.com/instrumentation](http://www.abb.com/instrumentation)

The Company's policy is one of continuous product improvement and the right is reserved to modify the information contained herein without notice.

Printed in Italy (04.09)

© ABB 2009



**ABB Ltd**  
Howard Road, St. Neots  
Cambridgeshire, PE19 8EU  
UK  
Tel: +44(0)1480 475321  
Fax: +44(0)1480 217948

**ABB Inc.**  
125 E. County Line Road  
Warminster, PA 18974  
USA  
Tel: +1 215 674 6000  
Fax: +1 215 674 7183

**ABB SACE**  
A division of ABB S.p.A.  
Via Statale 113  
22016 Lenno (CO) Italy  
Tel: +39 0344 58111  
Fax: +39 0344 56278