

## 2600T Series Pressure Transmitters

Model 268DS Differential

Model 268PS Gauge

Model 268VS Absolute

maximum working pressure up to 21MPa, 3045psi

**IndustrialIT**  
enabled™



- **TÜV SIL2 certified to IEC 61508**
  - the smart solution in Safety loop application
- **Best in Class Safety protection for your plants**
  - Safe Failure Fraction (SFF) : 98.6%
  - Diagnostic Coverage (DC) : 97.7%
  - Undetected Dangerous Failures  $\lambda_{DU}$  : 11 FIT
- **In-situ hardware redundancy (HFT=1)**
  - a guarantee of true protection
- **SIL3 capability in redundant architecture (1oo2)**
  - Software and hardware development process certified by TÜV
- **Reduced maintenance costs thanks to the longest proof test interval of 10 years for SIL2 in 1oo1 architecture**
- **Base accuracy :  $\pm 0.075\%$**
- **Span limits**
  - 0.14 to 16000kPa; 0.56inH<sub>2</sub>O to 2320psi
  - 0.27 to 16000kPa abs; 2mmHg to 2320psia
- **Hardware and software redundancy with MTBF of over 100 years**
- **5-year stability**
- **Full compliance with PED Category IV**
  - suitable for safety accessory application

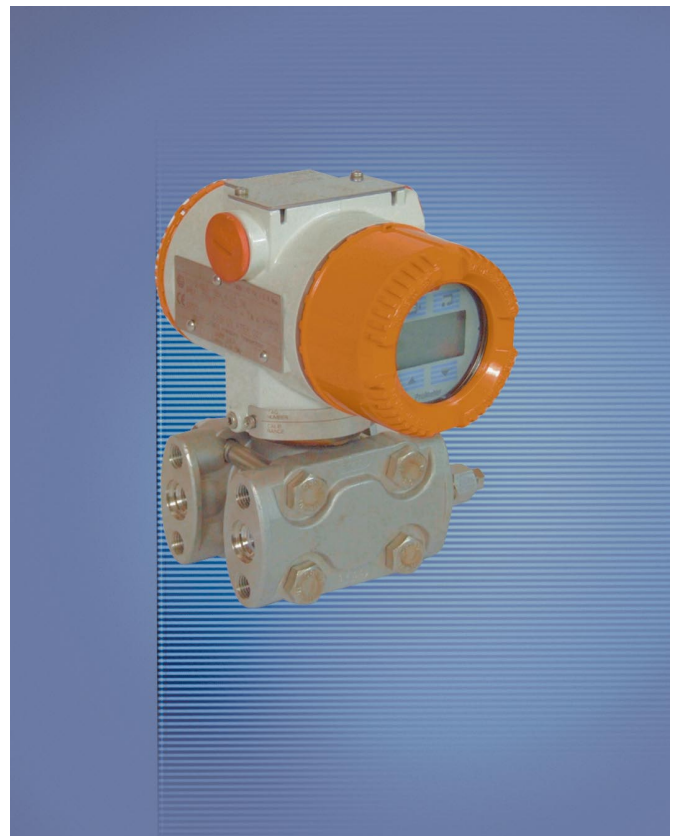

**ABB 2600T Series**  
**Engineered solutions**  
**for all applications**

## General Description

Model 268 is the IEC 61508 TÜV certified Safety 2600T transmitter for SIS and critical applications where safety and performances are the main requirement.

The transmitters detailed in this datasheets have been designed and manufactured according to a certified process which lead to a product specifically suitable for critical applications.

Thanks to the internal software and hardware redundancy, the 268 models have got the IEC 61508 certifications which not only allows installation in conformance with SIL2 (1oo1) but also to SIL3 in a 1oo2 architecture.

The 2600T Safety transmitter exceeds the IEC 61508 requirements for SIL2 with a Hardware Fault Tolerance of 1 (HFT = 1) and a Safe Failure Fraction of 98%.

In addition the following requirements of IEC 61508 have been assessed as part of the certification process:

- functional safety (hardware and software) testing;
- electrical safety testing;
- EMC testing;
- environmental testing;
- Quality Assurance in production and product maintenance;
- verification of the product development process.

Furthermore, with a very low Probability of Dangerous Undetected Failures ( $\lambda_{DU} = 11 \text{ FIT}$ ), the 2600T safety transmitters allow to extend the Proof Test Interval reducing maintenance costs by 50%.

## Functional Specifications

### Range and span limits

| Sensor Code | Upper Range Limit (URL)                     | Lower Range Limit (LRL)                        |  |   | Minimum span                                 |                               |
|-------------|---|--|--|---|--|-------------------------------|
|             |   | 268DS differential                             | 268PS gauge                                  | 268VS absolute                                    | 268DS differential<br>268PS gauge            | 268VS absolute                |
| <b>B</b>    | 4kPa<br>40mbar<br>16inH <sub>2</sub> O      | -4kPa<br>-40mbar<br>-16inH <sub>2</sub> O      | -4kPa<br>-40mbar<br>-16inH <sub>2</sub> O    |   | 0.14kPa<br>1.4mbar<br>0.56inH <sub>2</sub> O |                               |
| <b>E</b>    | 16kPa<br>160mbar<br>64inH <sub>2</sub> O    | -16kPa<br>-160mbar<br>-64inH <sub>2</sub> O    | -16kPa<br>-160mbar<br>-64inH <sub>2</sub> O  | 0.07kPa abs (§)<br>0.7mbar abs (§)<br>0.5mmHg (§) | 0.27kPa<br>2.7mbar<br>1.08inH <sub>2</sub> O | 0.27kPa<br>2.7mbar<br>2mmHg   |
| <b>F</b>    | 40kPa<br>400mbar<br>160inH <sub>2</sub> O   | -40kPa<br>-400mbar<br>-160inH <sub>2</sub> O   | -40kPa<br>-400mbar<br>-160inH <sub>2</sub> O | 0.07kPa abs (§)<br>0.7mbar abs (§)<br>0.5mmHg (§) | 0.4kPa<br>4mbar<br>1.6inH <sub>2</sub> O     | 0.67kPa<br>6.7mbar<br>5mmHg   |
| <b>G</b>    | 65kPa<br>650mbar<br>260inH <sub>2</sub> O   | -65kPa<br>-650mbar<br>-260inH <sub>2</sub> O   | -65kPa<br>-650mbar<br>-260inH <sub>2</sub> O | 0.07kPa abs (§)<br>0.7mbar abs (§)<br>0.5mmHg (§) | 0.65kPa<br>6.5mbar<br>2.6inH <sub>2</sub> O  | 1.1kPa<br>11mbar<br>8mmHg     |
| <b>H</b>    | 160kPa<br>1600mbar<br>642inH <sub>2</sub> O | -160kPa<br>-1600mbar<br>-642inH <sub>2</sub> O | 1kPa abs<br>10mbar abs<br>0.15 psia          | 0.07kPa abs (§)<br>0.7mbar abs (§)<br>0.5mmHg (§) | 1.6kPa<br>16mbar<br>6.4inH <sub>2</sub> O    | 2.67kPa<br>26.7mbar<br>20mmHg |
| <b>M</b>    | 600kPa<br>6bar<br>87psi                     | -600kPa<br>-6bar<br>-87psi                     | 1kPa abs<br>10mbar abs<br>0.15 psia          | 0.07kPa abs (§)<br>0.7mbar abs (§)<br>0.5mmHg (§) | 6kPa<br>0.06bar<br>0.87psi                   | 10kPa<br>0.1bar<br>1.45psi    |
| <b>P</b>    | 2400kPa<br>24bar<br>348psi                  | -2400kPa<br>-24bar<br>-348psi                  | 1kPa abs<br>10mbar abs<br>0.15 psia          | 0.07kPa abs (§)<br>0.7mbar abs (§)<br>0.5mmHg (§) | 24kPa<br>0.24bar<br>3.5psi                   | 40kPa<br>0.4bar<br>5.8psi     |
| <b>Q</b>    | 8000kPa<br>80bar<br>1160psi                 | -8000kPa<br>-80bar<br>-1160psi                 | 1kPa abs<br>10mbar abs<br>0.15 psia          | 0.07kPa abs (§)<br>0.7mbar abs (§)<br>0.5mmHg (§) | 80kPa<br>0.8bar<br>11.6psi                   | 134kPa<br>1.34bar<br>19.4psi  |
| <b>S</b>    | 16000kPa<br>160bar<br>2320psi               | -16000kPa<br>-160bar<br>-2320psi               | 1kPa abs<br>10mbar abs<br>0.15 psia          | 0.07kPa abs (§)<br>0.7mbar abs (§)<br>0.5mmHg (§) | 160kPa<br>1.6bar<br>23.2psi                  | 267kPa<br>2.67bar<br>38.7psi  |

(§) Lower Range Limits is 0.135kPa abs, 1.35mbar abs, 1mmHg for inert Galden or 0.4kPa abs, 4mbar abs, 3mmHg for inert Halocarbon.

### Span limits

Maximum span = URL  
(can be further adjusted up to  $\pm$  URL (TD = 0.5) for differential models, within the range limits)

IT IS RECOMMENDED TO SELECT THE TRANSMITTER SENSOR CODE PROVIDING THE TURNDOWN VALUE AS LOWEST AS POSSIBLE TO OPTIMIZE PERFORMANCE CHARACTERISTICS.

### Zero suppression and elevation

Zero and span can be adjusted to any value within the range limits detailed in the table as long as:

- calibrated span  $\geq$  minimum span

### Damping

Selectable time constant : 0, 0.25, 0.5, 1, 2, 4, 8 or 16s.  
This is in addition to sensor response time

### Turn on time

Operation within specification in less than 5s with minimum damping.

### Insulation resistance

> 100M $\Omega$  at 1000VDC (terminals to earth)

## Operative limits

### Temperature limits °C (°F) :

#### Ambient (is the operating temperature)

| Filling          | Models 268DS - 268PS          |                               | Model 268VS                   |                              |
|------------------|-------------------------------|-------------------------------|-------------------------------|------------------------------|
|                  | Sensors F to S                | Sensors B to E                | Sensors F to S                | Sensor code E                |
| Silicone oil     | -40 and +85<br>(-40 and +185) | -25 and +85<br>(-13 and +185) | -40 and +85<br>(-40 and +185) | -15 and +70<br>(+5 and +158) |
| Inert Galden     | -20 and +85<br>(-4 and +185)  | -10 and +85<br>(+14 and +185) | -10 and +65<br>(+14 and +150) | not applicable               |
| Inert Halocarbon | -20 and +85<br>(-4 and +185)  | -10 and +85<br>(+14 and +185) | -10 and +65<br>(+14 and +150) | not applicable               |

Inert fillings not available for sensor B

Lower ambient limit for LCD indicators: -20°C (-4°F)

Upper ambient limit for LCD indicators: +70°C (+158°F)

Note : For Hazardous Atmosphere applications see the temperature range specified on the certificate/approval relevant to the aimed type of protection

#### Process

Lower limit

- refer to lower ambient limits; -20°C (-4°F) for Viton gasket

Upper limit

- Silicone oil: 121°C (250°F) (1)

- Inert fluid: 100°C (212°F) (2)

(1) 100°C (212°F) for application below atmospheric pressure

(2) 65°C (150°F) for application below atmospheric pressure

#### Storage

Lower limit: -50°C (-58°F); -40°C (-40°F) for LCD indicators

Upper limit: +85°C (+185°F)

## Pressure limits

### Overpressure limits (without damage to the transmitter)

0.07kPa abs, 0.7mbar abs, 0.01psia (0.135kPa abs, 1.35mbar abs, 1mmHg for inert Galden or 0.4kPa abs, 4mbar abs, 3mmHg for inert Halocarbon) to

- 7MPa, 70bar, 1015psi for sensor code B

- 16MPa, 160bar, 2320psi for sensor code E

- 21MPa, 210bar, 3045psi for sensor codes F to S

### Static pressure

Transmitters for differential pressure model 268DS operates within specifications between the following limits

- sensor code B:

1.3kPa abs, 13mbar abs, 0.2psia and 7MPa, 70bar, 1015psi

- sensor code E:

1.3kPa abs, 13mbar abs, 0.2psia and 16MPa, 160bar, 2320psi

- sensor codes F to S:

1.3kPa abs, 13mbar abs, 0.2psia and 21MPa, 210bar, 3045psi

### Proof pressure

The transmitter can be exposed without leaking to line pressure of up to 48MPa, 480bar, 6960psi. Meet ANSI/ISA-S 82.03 hydrostatic test requirements.

## Environmental limits

### Electromagnetic compatibility (EMC)

Comply with EN 61000-6-3 for emission and EN 61000-6-2 for immunity requirements and test;

Radiated electromagnetic immunity level: 30V/m  
(according to IEC 1000-4-3, EN61000-4-3)

Conducted electromagnetic immunity level : 10V  
(according to IEC 1000-4-6, EN 61000-4-6)

Surge immunity level (with surge protector): 4kV  
(according to IEC 1000-4-5 EN 61000-4-5)

Fast transient (Burst) immunity level: 4kV  
(according to IEC 1000-4-4 EN 61000-4-4)

### Pressure equipment directive (PED)

Comply with 97/23/EEC Category IV Modules D and B.

### Humidity

Relative humidity: up to 100% annual average

Condensing, icing: admissible

### Vibration resistance

Accelerations up to 2g at frequency up to 1000Hz  
(according to IEC 60068-2-6)

### Shock resistance

Acceleration: 50g

Duration: 11ms

(according to IEC 60068-2-27)

### Wet and dust-laden atmospheres

The transmitter is dust and sand tight and protected against immersion effects as defined by EN 60529 (1989) to IP 67 (IP 68 on request) or by NEMA to 4X or by JIS to C0920. IP65 with Harting Han connector.

### Hazardous atmospheres

With or without output meter

- INTRINSIC SAFETY and EXPLOSION PROOF/EUROPE:

ATEX/ZELM approval

II 1G Ex ia IIC T6 and II 1/2G Ex ia IIC T6 and

II 1D Ex iaD 20 T95°C and II 1/2D Ex iaD 21 T95°C

resp. II 1/2G Ex d IIC T6 and II 1/2D Ex tD A21 IP67 T85°C

- CANADIAN STANDARD ASSOCIATION and FACTORY MUTUAL:

- Explosionproof: Class I, Div. 1, Groups A, B, C, D

- Dust ignitionproof : Class II, Div. 1, Groups E, F, G

- Suitable for : Class II, Div. 2, Groups F, G; Class III, Div. 1, 2

- Nonincendive: Class I, Div. 2, Groups A, B, C, D

- Intrinsically safe: Class I, II, III, Div. 1, Groups A, B, C, D, E, F, G  
AEx ia IIC T6/T4, Zone 0 (FM)

- GOST (Russia), GOST (Kazakistan), Inmetro (Brazil - pending)  
based on ATEX

## Electrical Characteristics and Options

### HART digital communication and 4 to 20mA output

#### Power Supply

The transmitter operates from 10.5 to 42VDC with no load and is protected against reverse polarity connection (additional load allows operations over 42VDC).

For EEx ia and other intrinsically safe approval power supply must not exceed 30VDC.

#### Ripple

20mV max on a 250Ω load as per HART specifications

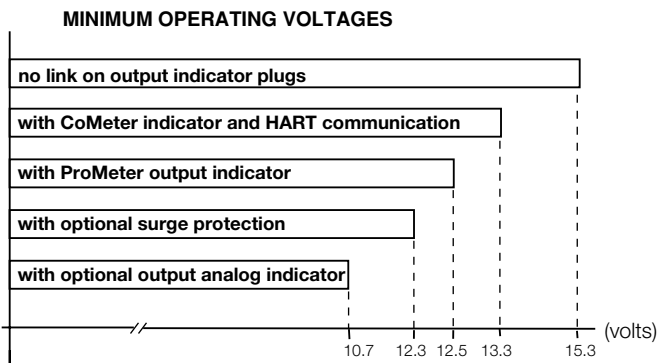

#### Load limitations

4 to 20mA and HART total loop resistance :

$$R(k\Omega) = \frac{\text{Supply voltage} - \text{min. operating voltage (VDC)}}{22.5}$$

A minimum of 250Ω is required for HART communication.

### Optional indicators

#### Output meter

CoMeter and Prometer LCD :

5-digit ( $\pm 99999$  counts) programmable with 7.6mm. high (3in), 7-segment numeric characters plus sign and digital point for digital indication of output value in percentage, current or engineer unit;

10-segment bargraph display (10% per segment) for analog indication of output in percentage;

7-digit with 6mm. high (2.3in), 14-segment alphanumeric characters, for engineer units and configuration display

Analog : 36mm (1.4in) scale on 90°.

#### Optional surge protection

Up to 4kV

– voltage 1.2 μs rise time / 50 μs delay time to half value

– current 8 μs rise time / 20 μs delay time to half value

#### Output signal

Two-wire 4 to 20mA, user-selectable for linear or square root output, power of  $3/2$  or  $5/2$ , 5th order or two 2nd order switching point selectable programmable polynomial output.

HART® communication provides digital process variable (% , mA or engineering units) superimposed on 4 to 20mA signal, with protocol based on Bell 202 FSK standard.

#### Output current limits (to NAMUR standard)

Low saturation: 3.8mA (field configurable from 3.5 to 4mA)

High saturation: 20.5mA (field configurable from 20 to 22.5mA)

#### Alarm current

Low alarm current: 3.7mA (field configurable from 3.5 to 4mA)

High alarm current: 22mA (field configurable from 20 to 22.5mA)

Factory setting: high alarm current

## Performance specifications

Stated at reference condition to IEC 60770 ambient temperature of 20°C (68°F), relative humidity of 65%, atmospheric pressure of 1013hPa (1013mbar), mounting position with vertical diaphragm and zero based range for transmitter with isolating diaphragms in AISI 316 L ss or Hastelloy and silicone oil fill and digital trim values equal to span end points, in linear mode.

Unless otherwise specified, errors are quoted as % of span.

Some performance data are affected by the actual turndown (TD) as ratio between Upper Range Limit (URL) and calibrated span.

IT IS RECOMMENDED TO SELECT THE TRANSMITTER SENSOR CODE PROVIDING THE TURNDOWN VALUE AS LOWEST AS POSSIBLE TO OPTIMIZE PERFORMANCE CHARACTERISTICS.

### Dynamic performance (according to IEC 61298–1 definition)

Dead time: 40ms

Time constant (63.2% of total step change):

– sensors M to S: ≤ 70ms

– sensor H: 100ms

– sensor G: 130ms

– sensor F: 180ms

Response time (total) = dead time + time constant

### Accuracy rating

% of calibrated span, including combined effects of terminal based linearity, hysteresis and repeatability.

Model 268DS, 268PS

– ±0.075% for TD from 1:1 to 15:1  
(±0.10% for sensor code B for TD from 1:1 to 10:1)

–  $\pm 0.005\% \times \frac{\text{URL}}{\text{Span}}$  for TD from 15:1 to 60:1  
(30:1 for sensor code E)

( $\pm 0.01\% \times \frac{\text{URL}}{\text{Span}}$  for sensor code B for TD from 10:1 to 20:1)

Models 268VS

– ±0.075% for TD from 1:1 to 10:1

–  $\pm 0.0075\% \times \frac{\text{URL}}{\text{Span}}$  for TD from 10:1 to 20:1

## Operating influences

### Ambient temperature

per 20K (36°F) change between the limits of –20°C to +65°C (–4 to +150°F) :

| Model          | Sensor Code | for TD up to |                             |
|----------------|-------------|--------------|-----------------------------|
| 268DS<br>268PS | E to S      | 15:1         | ± (0.04% URL + 0.065% span) |
|                | B           | 10:1         | ± (0.06% URL + 0.10% span)  |
| 268VS          | E to S      | 10:1         | ± (0.08% URL + 0.13% span)  |

### Optional CoMeter and ProMeter ambient temperature

Total reading error per 20K (36°F) change between the ambient limits of –20 and +70°C (–4 and +158°F) :

±0.15% of max span (16mA).

### Static pressure (zero errors can be calibrated out at line pressure)

per 2MPa, 20bar or 290psi (sensor code B)

per 7MPa, 70bar or 1015psi (sensor codes E to S)

#### Model 268DS

– zero error: ±0.08% of URL

– span error: ±0.08% of reading

Multiply by 2 the errors for sensor code E.

### Supply voltage

Within voltage/load specified limits the total effect is less than 0.005% of URL per volt.

### Load

Within load/voltage specified limits the total effect is negligible.

### Electromagnetic field

Total effect : less than 0.10% of span from 20 to 1000MHz and for field strengths up to 30V/m when tested with shielded conduit and grounding, with or without meter.

### Common mode interference

No effect from 100Vrms @ 50Hz, or 50VDC

### Mounting position

Rotations in plane of diaphragm have negligible effect. A tilt to 90° from vertical causes a zero shifts up to 0.5kPa, 5mbar or 2inH<sub>2</sub>O, which can be corrected with the zero adjustment. No span effect.

### Stability

±0.15% of URL over a ten years period  
(for 268DS and 268PS sensor F and G)

### Vibration effect

±0.10% of URL (according to IEC 61298–3)

## Physical Specification

(Refer to ordering information sheets for variant availability related to specific model or versions code)

### Materials

#### Process isolating diaphragms (\*)

AISI 316 L ss; AISI 316 L ss gold plated; Monel 400™; Tantalum;  
Hastelloy C276™; Hastelloy C276™ on AISI 316L ss gasket seat.

#### Process flanges, adapters, plugs and drain/vent valves (\*)

AISI 316 L ss; Hastelloy C276™; Monel 400™.

#### Blind flange (reference side of 268PS, 268VS)

AISI 316 L ss.

#### Sensor fill fluid

Silicone oil (DC200™); inert fill (Halocarbon™ 4.2 or Galden™).

#### Mounting bracket (\*\*)

Zinc plated carbon steel with chrome passivation;  
AISI 316 L ss.

#### Gaskets (\*)

Viton™; PTFE.

#### Sensor housing

AISI 316 L ss.

#### Bolts and nuts

AISI 316 ss bolts Class A4–80 and nuts Class A4–70 per UNI 7323 (ISO 3506);

AISI 316 ss bolts and nuts Class A4–50 per UNI 7323 (ISO 3506), in compliance with NACE MR0175 Class II.

Plated alloy steel bolts per ASTM-A-193-77a grade B7M and nuts per ASTM A194/A 194 M-90 grade 2HM, in compliance with NACE MR0175 Class II.

#### Electronic housing and covers

Barrel version

- Aluminium alloy with baked epoxy finish;
- Copper-free content aluminium alloy with baked epoxy finish;
- AISI 316 L ss.

DIN version

- Aluminium alloy with baked epoxy finish.

#### Covers O-ring

Buna N.

#### Local zero and span adjustments:

Glass filled polycarbonate plastic (removable).

#### Tagging

AISI 316ss data plate attached to the electronics housing.

## Calibration

Standard: at maximum span, zero based range, ambient temperature and pressure;

Optional: at specified range and ambient conditions.

## Optional extras

### Mounting brackets

For vertical and horizontal 60mm. (2in) pipes or wall mounting.

### Output indicator

plug-in rotatable type, LCD or analog.

### Supplemental customer tag

AISI 316 ss tag screwed/fastened to the transmitter for customer's tag data up to a maximum of 20 characters and spaces on one line for tag number and tag name, and up to a maximum of 3 spaced strings of 10 characters each for calibration details (lower and upper values plus unit). Special typing evaluated on request for charges.

### Surge protection

### Cleaning procedure for oxygen service

### Hydrogen or special service preparation

### Test Certificates (test, design, calibration, material traceability)

### Tag and manual language

### Communication connectors

### Process connections

on flanges :  $\frac{1}{4}$  – 18 NPT on process axis

on adapters :  $\frac{1}{2}$  – 14 NPT on process axis

centre distance (268DS): 54mm (2.13in) on flange;  
51,54 or 57mm (2.01, 2.13 or 2.24in) as per adapters fittings

fixing threads:  $\frac{7}{16}$  – 20 UNF at 41.3mm centre distance

### Electrical connections

Two  $\frac{1}{2}$  – 14 NPT or M20x1.5 or PG 13.5 or  $\frac{1}{2}$  GK threaded conduit entries, direct on housing.

Special communication connector (on request)

- HART : straight or angle Harting Han connector and one plug.

### Terminal block

HART version: three terminals for signal/external meter wiring up to 2.5mm<sup>2</sup> (14AWG) and three connection points for test and communication purposes.

### Grounding

Internal and external 6mm<sup>2</sup> (10AWG) ground termination points are provided.

### Mounting position

Transmitter can be mounted in any position.

Electronics housing may be rotated to any position. A positive stop prevents over travel.

### Mass (without options)

3.5kg approx (8lb); add 1.5kg (3.4lb) for AISI housing.  
Add 650g (1.5lb) for packing.

### Packing

Carton 26 x 26 x 18cm approx (10 x 10 x 7in).

(\*) Wetted parts of the transmitter.

(\*\*) U-bolt material: AISI 400 ss; screws material: high-strength alloy steel or AISI 316 ss.

**Configuration**

**Transmitter with HART communication and 4 to 20 mA**

**Standard configuration**

Transmitters are factory calibrated to customer's specified range. Calibrated range and tag number are stamped on the tag plate. If a calibration range and tag data are not specified, the transmitter will be supplied with the plate left blank and configured as follows:

|                                 |                         |
|---------------------------------|-------------------------|
| Engineering Unit                | kPa                     |
| 4 mA                            | Zero                    |
| 20 mA                           | Upper Range Limit (URL) |
| Output                          | Linear                  |
| Damping                         | 1 sec.                  |
| Transmitter failure mode        | Upscale                 |
| Software tag (8 characters max) | Blank                   |
| Optional LCD indicator/display  | 0 to 100.0% linear      |

Any or all the above configurable parameters, including Lower range-value and Upper range-value which must be the same unit of measure, can be easily changed using the HART hand-held communicator or by a PC running the configuration software SMART VISION with DTM for 2600T. The transmitter database is customized with specified flange type and material, O-ring and drain/vent materials and meter code option. Custom configuration (option)

The following data may be specified in addition to the standard configuration parameters:

|            |                            |
|------------|----------------------------|
| Descriptor | 16 alphanumeric characters |
| Message    | 32 alphanumeric characters |
| Date       | Day, month, year           |

For any protocol available engineering units of pressure measure are :  
 Pa, kPa, MPa  
 inH<sub>2</sub>O@4°C, mmH<sub>2</sub>O@4°C, psi  
 inH<sub>2</sub>O@20°C, ftH<sub>2</sub>O@20°C, mmH<sub>2</sub>O@20°C  
 inHg, mmHg, Torr  
 g/cm<sup>2</sup>, kg/cm<sup>2</sup>, atm  
 mbar, bar

**MOUNTING DIMENSIONS** (not for construction unless certified) – dimensions in mm (in)

**Transmitter with flanges for vertical connection (Barrel housing)**

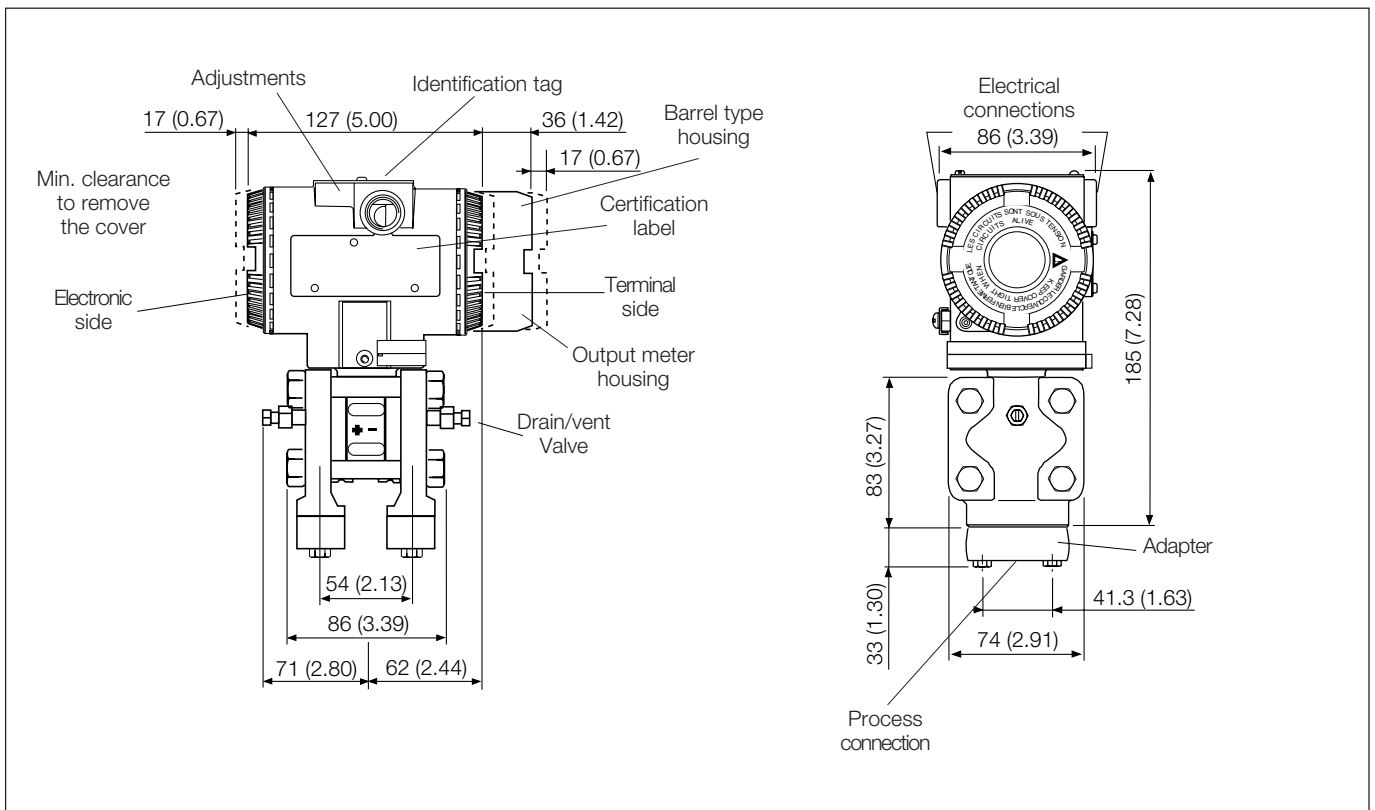

**Transmitter with barrel aluminium housing on bracket for vertical or horizontal 60mm (2in) pipe mounting**

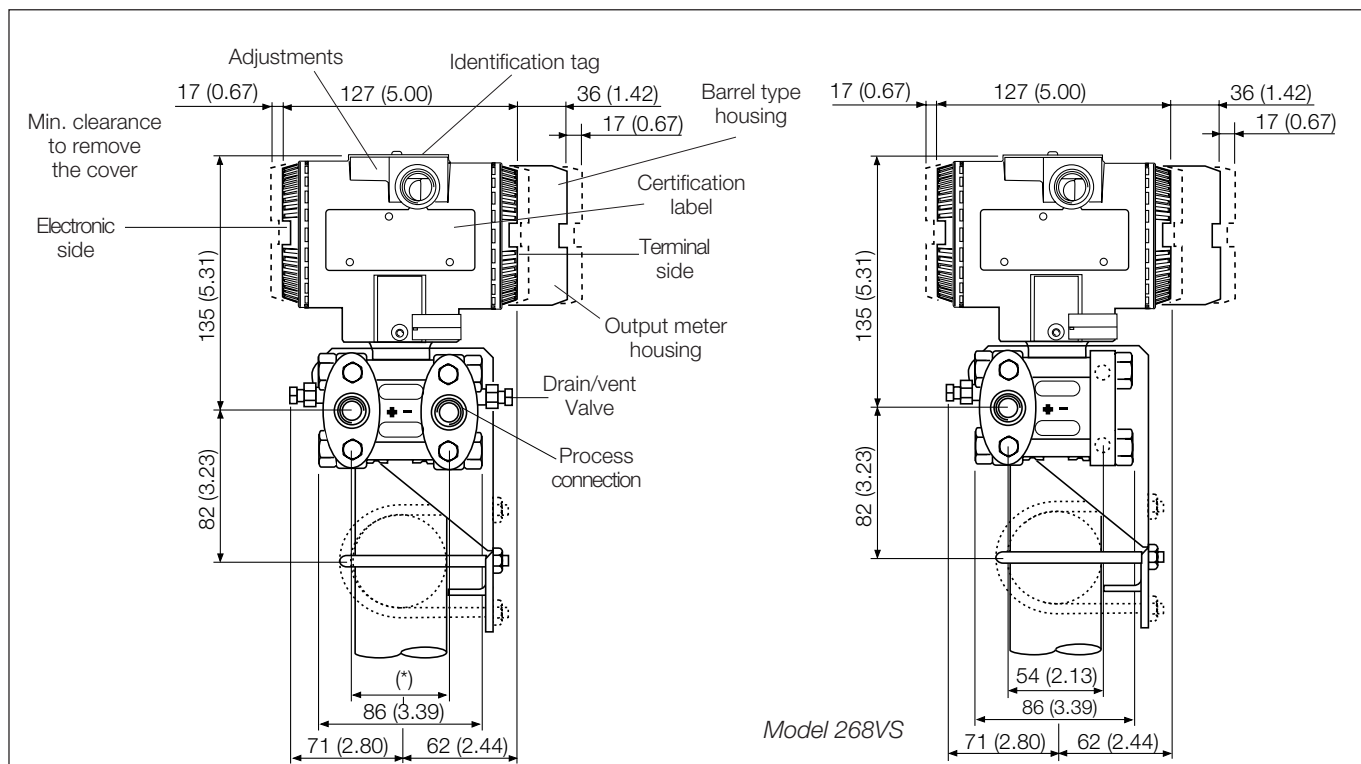

(\*) FOR MODEL 268DS  
 51 (2.01), 54 (2.13) or 57 (2.24) mm (in) according to 1/2 – 14 NPT adapters fitting; 54 (2.13) mm (in) on 1/4 – 18 NPT process flange  
 FOR MODEL 268PS  
 54 (2.13) mm (in) with low pressure side flange without process connection (a filter is fitted) and drain/vent valve

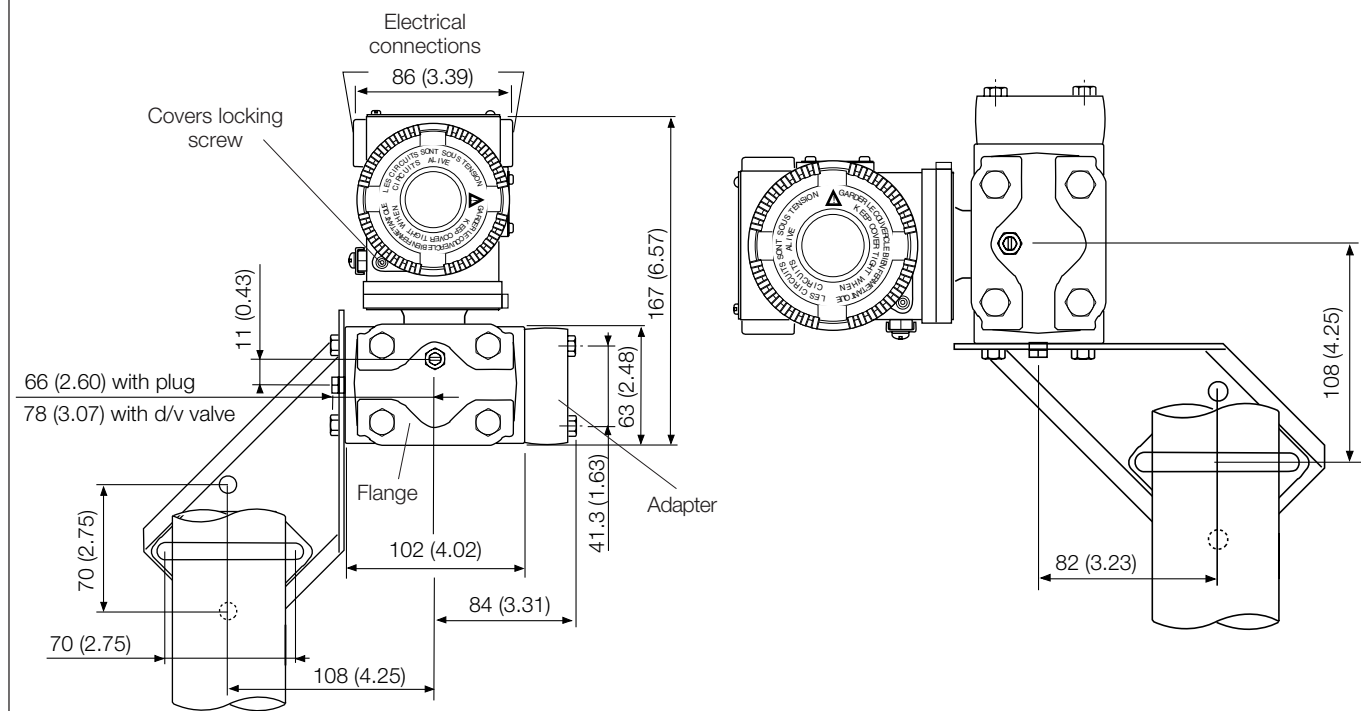

NOTE : Process connection, gasket groove and gaskets are in accordance with DIN 19213. Bolting threads for fixing adapter or other devices (i.e. manifold etc.) on process flange is 7/16 – 20 UNF.

**Transmitter on bracket for vertical or horizontal 60 mm (2in) pipe mounting (DIN housing)**

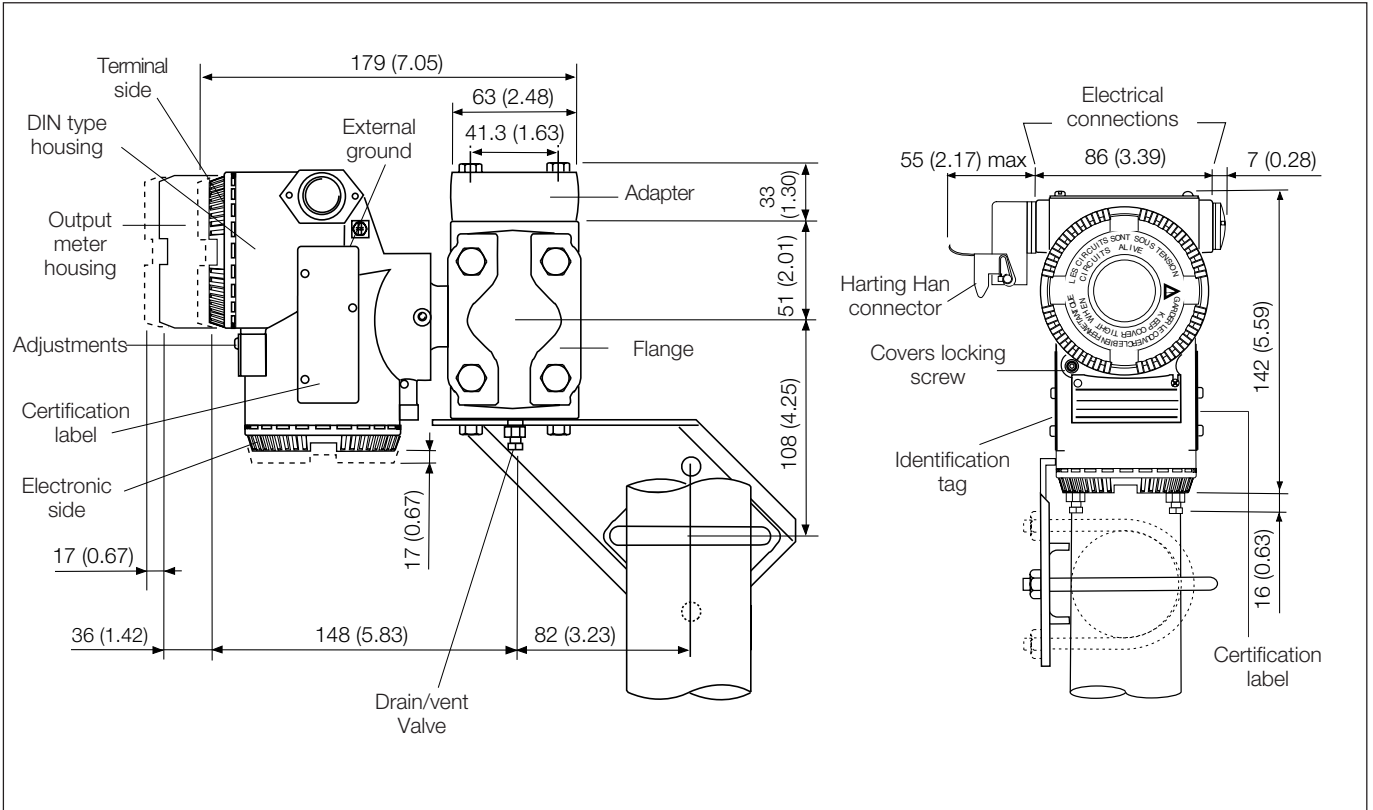

**Transmitter with barrel AISI ss housing on bracket (flat type for box) for vertical or horizontal 60mm (2in) pipe mounting**

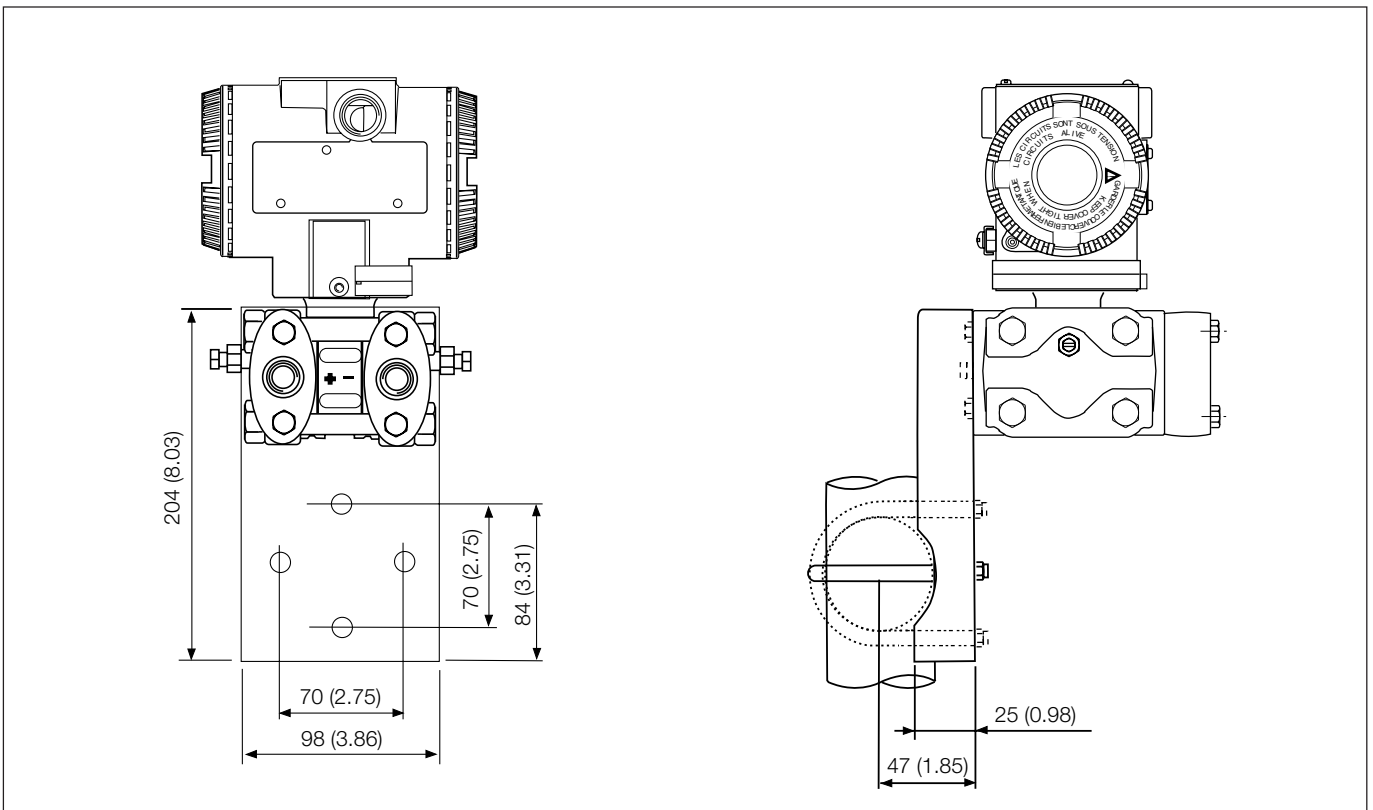

**Transmitter on bracket for wall mounting (by up to four M8 screws, NOT SUPPLIED)**

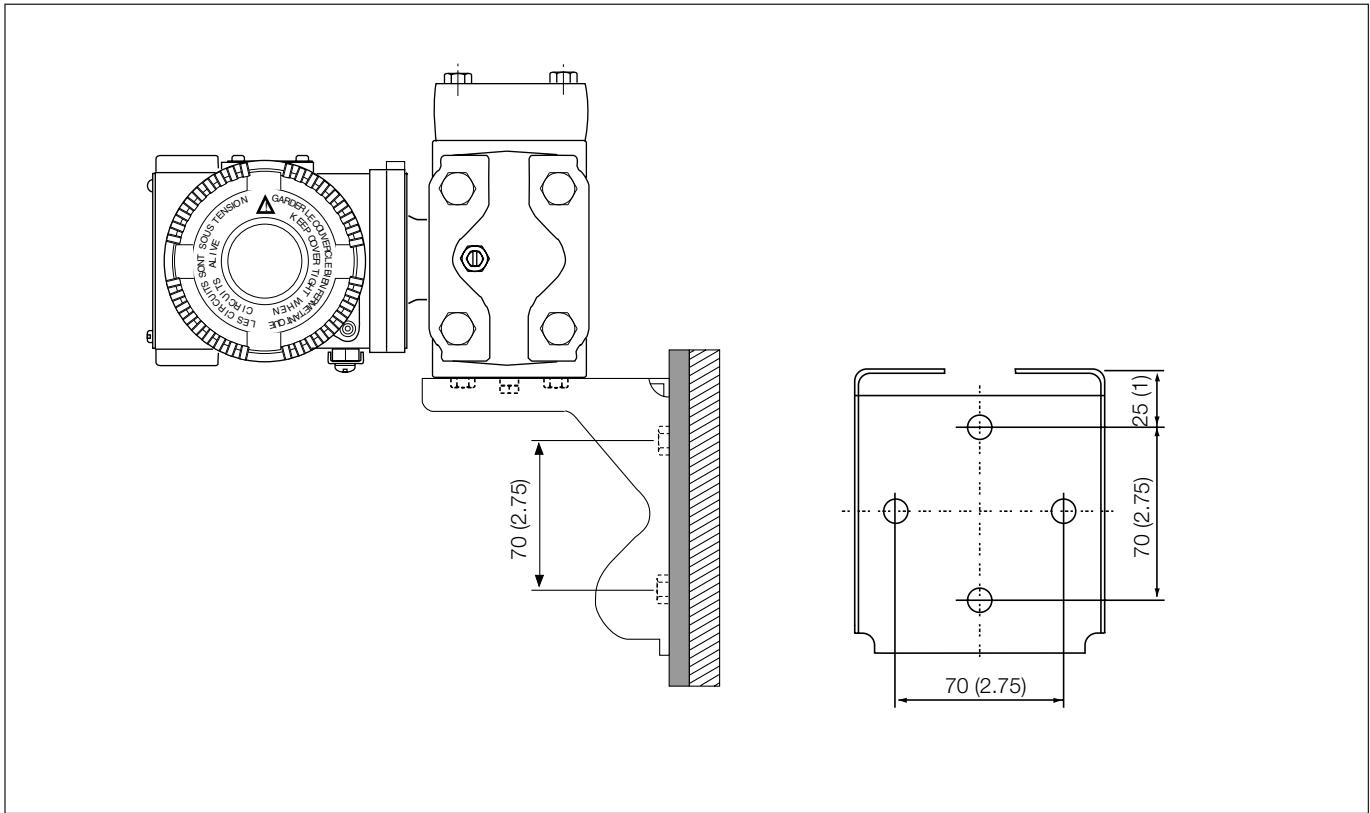

**Electrical connections**

**HART Version**

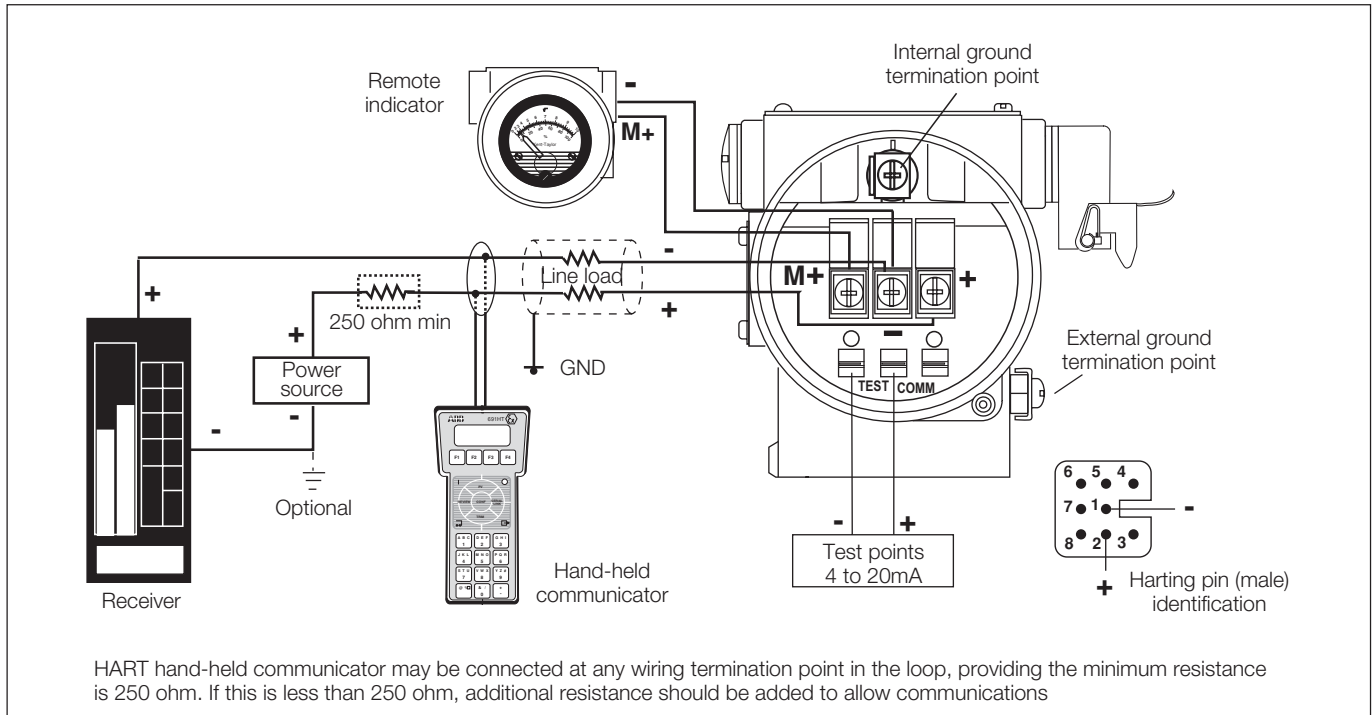

**BASIC ORDERING INFORMATION model 268DS Safety Differential Pressure Transmitter**

Select one character or set of characters from each category and specify complete catalog number.  
 Refer to additional ordering information code and specify one or more codes for each transmitter if additional options are required.

| BASE MODEL – 1 <sup>st</sup> to 5 <sup>th</sup> characters  |   |                               | 2 | 6 | 8 | D | S | X        | S | X | X | X | X | X |  |
|---|---|-------------------------------|---|---|---|---|---|----------|---|---|---|---|---|---|--|
| Safety Differential Pressure Transmitter – BASE ACCURACY 0.075%                                   |   |                               |   |   |   |   |   |          |   |   |   |   |   |   |  |
| <b>SENSOR - Span limits – 6<sup>th</sup> character</b>  |   |                               |   |   |   |   |   |          |   |   |   |   |   |   |  |
| 0.14 and 4kPa   | 1.4 and 40mbar  | 0.56 and 16inH <sub>2</sub> O |   |   |   |   |   | B        |   |   |   |   |   |   |  |
| 0.27 and 16kPa  | 2.7 and 160mbar   | 1.08 and 64inH <sub>2</sub> O |   |   |   |   |   | E        |   |   |   |   |   |   |  |
| 0.4 and 40kPa   | 4 and 400mbar   | 1.6 and 160inH <sub>2</sub> O |   |   |   |   |   | F        |   |   |   |   |   |   |  |
| 0.65 and 65kPa  | 6.5 and 650mbar   | 2.6 and 260inH <sub>2</sub> O |   |   |   |   |   | G        |   |   |   |   |   |   |  |
| 1.6 and 160kPa  | 16 and 1600mbar   | 6.4 and 642inH <sub>2</sub> O |   |   |   |   |   | H        |   |   |   |   |   |   |  |
| 6 and 600kPa  | 0.06 and 6bar   | 0.87 and 87psi                |   |   |   |   |   | M        |   |   |   |   |   |   |  |
| 24 and 2400kPa  | 0.24 and 24bar  | 3.5 and 348psi                |   |   |   |   |   | P        |   |   |   |   |   |   |  |
| 80 and 8000kPa  | 0.8 and 80bar   | 11.6 and 1160psi              |   |   |   |   |   | Q        |   |   |   |   |   |   |  |
| 160 and 16000kPa  | 1.6 and 160bar  | 23.2 and 2320psi              |   |   |   |   |   | S        |   |   |   |   |   |   |  |
| <b>Use code – 7<sup>th</sup> character</b>  |   |                               |   |   |   |   |   |          | S |   |   |   |   |   |  |
| <b>Diaphragm material / Fill fluid (wetted parts) – 8<sup>th</sup> character</b>                  |   |                               |   |   |   |   |   |          |   |   |   |   |   |   |  |
| AISI 316 L ss   | Silicone oil  | (Note 2)                      |   |   |   |   |   |          | S |   |   |   |   |   |  |
| Hastelloy C276™ (on AISI seat)  | Silicone oil  |                               |   |   |   |   |   | NACE     | H |   |   |   |   |   |  |
| Hastelloy C276™   | Silicone oil  |                               |   |   |   |   |   | NACE     | K |   |   |   |   |   |  |
| Monel 400™  | Silicone oil  | (Note 2)                      |   |   |   |   |   | NACE     | M |   |   |   |   |   |  |
| AISI 316 L ss gold plated   | Silicone oil  | (Note 2)                      |   |   |   |   |   |          | 8 |   |   |   |   |   |  |
| Tantalum  | Silicone oil  | (Note 2)                      |   |   |   |   |   | NACE     | T |   |   |   |   |   |  |
| AISI 316 L ss   | Inert fluid - Galden  | (Notes 1, 2)                  |   |   |   |   |   |          | A |   |   |   |   |   |  |
| Hastelloy C276™ (on AISI seat)  | Inert fluid - Galden  | (Notes 1, 2)                  |   |   |   |   |   | NACE     | B |   |   |   |   |   |  |
| Hastelloy C276™   | Inert fluid - Galden  | (Notes 1, 2)                  |   |   |   |   |   | NACE     | F |   |   |   |   |   |  |
| Monel 400™  | Inert fluid - Galden  | (Notes 1, 2)                  |   |   |   |   |   | NACE     | C |   |   |   |   |   |  |
| AISI 316 L ss gold plated   | Inert fluid - Galden  | (Notes 1, 2)                  |   |   |   |   |   |          | 9 |   |   |   |   |   |  |
| Tantalum  | Inert fluid - Galden  | (Notes 1, 2)                  |   |   |   |   |   | NACE     | D |   |   |   |   |   |  |
| AISI 316 L ss   | Inert fluid - Halocarbon  | (Notes 1, 2)                  |   |   |   |   |   |          | L |   |   |   |   |   |  |
| Hastelloy C276™ (on AISI seat)  | Inert fluid - Halocarbon  | (Notes 1, 2)                  |   |   |   |   |   | NACE     | Q |   |   |   |   |   |  |
| Hastelloy C276™   | Inert fluid - Halocarbon  | (Notes 1, 2)                  |   |   |   |   |   | NACE     | P |   |   |   |   |   |  |
| Monel 400™  | Inert fluid - Halocarbon  | (Notes 1, 2)                  |   |   |   |   |   | NACE     | 4 |   |   |   |   |   |  |
| AISI 316 L ss gold plated   | Inert fluid - Halocarbon  | (Notes 1, 2)                  |   |   |   |   |   |          | I |   |   |   |   |   |  |
| Tantalum  | Inert fluid - Halocarbon  | (Notes 1, 2)                  |   |   |   |   |   | NACE     | 5 |   |   |   |   |   |  |
| <b>Process flanges/adapters material and connection (wetted parts) – 9<sup>th</sup> character</b> |   |                               |   |   |   |   |   |          |   |   |   |   |   |   |  |
| AISI 316 L ss (Horizontal connection)   | 1/4 – 18 NPT-f direct (7/16 – 20 UNF U.S. drilling)             |                               |   |   |   |   |   | NACE     | A |   |   |   |   |   |  |
| AISI 316 L ss (Horizontal connection)   | 1/2 – 14 NPT-f through adapter (7/16 – 20 UNF U.S. drilling)    |                               |   |   |   |   |   | NACE     | B |   |   |   |   |   |  |
| Hastelloy C276™ (Horizontal connection)   | 1/4 – 18 NPT-f direct (7/16 – 20 UNF U.S. drilling)             | (Note 3)                      |   |   |   |   |   | NACE     | D |   |   |   |   |   |  |
| Hastelloy C276™ (Horizontal connection)   | 1/2 – 14 NPT-f through adapter (7/16 – 20 UNF U.S. drilling)    | (Note 3)                      |   |   |   |   |   | NACE     | E |   |   |   |   |   |  |
| Monel 400™ (Horizontal connection)  | 1/4 – 18 NPT-f direct (7/16 – 20 UNF U.S. drilling)             | (Note 3)                      |   |   |   |   |   | NACE     | G |   |   |   |   |   |  |
| Monel 400™ (Horizontal connection)  | 1/2 – 14 NPT-f through adapter (7/16 – 20 UNF U.S. drilling)    | (Note 3)                      |   |   |   |   |   | NACE     | H |   |   |   |   |   |  |
| AISI 316 L ss (Vertical connection)   | 1/4 – 18 NPT-f direct (7/16 – 20 UNF U.S. drilling)             |                               |   |   |   |   |   | NACE     | Q |   |   |   |   |   |  |
| AISI 316 L ss (Vertical connection)   | 1/2 – 14 NPT-f through adapter (7/16 – 20 UNF U.S. drilling)    |                               |   |   |   |   |   | NACE     | T |   |   |   |   |   |  |
| Hastelloy C276™ (Vertical connection)   | 1/4 – 18 NPT-f direct (7/16 – 20 UNF U.S. drilling)             | (Note 3)                      |   |   |   |   |   | NACE     | M |   |   |   |   |   |  |
| Hastelloy C276™ (Vertical connection)   | 1/2 – 14 NPT-f through adapter (7/16 – 20 UNF U.S. drilling)    | (Note 3)                      |   |   |   |   |   | NACE     | S |   |   |   |   |   |  |
| Monel 400™ (Vertical connection)  | 1/4 – 18 NPT-f direct (7/16 – 20 UNF U.S. drilling)             | (Note 3)                      |   |   |   |   |   | NACE     | U |   |   |   |   |   |  |
| Monel 400™ (Vertical connection)  | 1/2 – 14 NPT-f through adapter (7/16 – 20 UNF U.S. drilling)    | (Note 3)                      |   |   |   |   |   | NACE     | V |   |   |   |   |   |  |
| <b>Bolts/Gasket (wetted parts) – 10<sup>th</sup> character</b>                                    |   |                               |   |   |   |   |   |          |   |   |   |   |   |   |  |
| AISI 316 ss   | Viton™  |                               |   |   |   |   |   |          |   |   |   |   |   | 1 |  |
| AISI 316 ss   | PTFE  | (Note 1)                      |   |   |   |   |   |          |   |   |   |   |   | 2 |  |
| AISI 316 ss (NACE) – (MWP = 16MPa)  | Viton™  |                               |   |   |   |   |   | NACE     |   |   |   |   |   | 3 |  |
| AISI 316 ss (NACE) – (MWP = 16MPa)  | PTFE  | (Note 1)                      |   |   |   |   |   | NACE     |   |   |   |   |   | 4 |  |
| Alloy steel (NACE)  | Viton™  |                               |   |   |   |   |   | NACE     |   |   |   |   |   | 8 |  |
| Alloy steel (NACE)  | PTFE  | (Note 1)                      |   |   |   |   |   | NACE     |   |   |   |   |   | 9 |  |
| <b>Housing material and electrical connection – 11<sup>th</sup> character</b>                     |   |                               |   |   |   |   |   |          |   |   |   |   |   |   |  |
| Aluminium alloy (Barrel version)  | 1/2 – 14 NPT  |                               |   |   |   |   |   |          |   |   |   |   |   | A |  |
| Aluminium alloy (Barrel version)  | M20 x 1.5 (CM 20)   |                               |   |   |   |   |   |          |   |   |   |   |   | B |  |
| Aluminium alloy (Barrel version)  | Pg 13.5   |                               |   |   |   |   |   |          |   |   |   |   |   | D |  |
| Aluminium alloy (Barrel version)  | 1/2 GK  |                               |   |   |   |   |   |          |   |   |   |   |   | C |  |
| Aluminium alloy (Barrel version)  | Harting Han connector   | (general purpose only)        |   |   |   |   |   | (Note 4) |   |   |   |   |   | E |  |
| Aluminium alloy copper-free (Barrel version)  | 1/2 – 14 NPT  |                               |   |   |   |   |   |          |   |   |   |   |   | H |  |
| Aluminium alloy copper-free (Barrel version)  | M20 x 1.5 (CM 20)   |                               |   |   |   |   |   |          |   |   |   |   |   | L |  |
| Aluminium alloy copper-free (Barrel version)  | Pg 13.5   |                               |   |   |   |   |   |          |   |   |   |   |   | N |  |
| Aluminium alloy copper-free (Barrel version)  | 1/2 GK  |                               |   |   |   |   |   |          |   |   |   |   |   | M |  |
| Aluminium alloy copper-free (Barrel version)  | Harting Han connector   | (general purpose only)        |   |   |   |   |   | (Note 4) |   |   |   |   |   | P |  |
| AISI 316 L ss (Barrel version)  | 1/2 – 14 NPT  |                               |   |   |   |   |   |          |   |   |   |   |   | S |  |
| AISI 316 L ss (Barrel version)  | M20 x 1.5 (CM20)  |                               |   |   |   |   |   |          |   |   |   |   |   | T |  |
| AISI 316 L ss (Barrel version)  | Pg 13.5   |                               |   |   |   |   |   |          |   |   |   |   |   | V |  |
| AISI 316 L ss (Barrel version)  | 1/2 GK  |                               |   |   |   |   |   |          |   |   |   |   |   | U |  |
| Aluminium alloy (DIN version)   | M20 x 1.5 (CM 20)   | (general purpose only)        |   |   |   |   |   |          |   |   |   |   |   | J |  |
| Aluminium alloy (DIN version)   | Pg 13.5   | (general purpose only)        |   |   |   |   |   |          |   |   |   |   |   | Y |  |
| Aluminium alloy (DIN version)   | Harting Han connector   | (general purpose only)        |   |   |   |   |   | (Note 4) |   |   |   |   |   | K |  |
| <b>Output/Additional options – 12<sup>th</sup> character</b>                                      |   |                               |   |   |   |   |   |          |   |   |   |   |   |   |  |
| HART digital communication and 4 to 20mA (SIL 2)  | No additional options   |                               |   |   |   |   |   | (Note 5) |   |   |   |   |   | T |  |
| HART digital communication and 4 to 20mA (SIL 2)  | Options requested (to be ordered by "Additional ordering code") |                               |   |   |   |   |   |          |   |   |   |   |   | 8 |  |

**ADDITIONAL ORDERING INFORMATION for model 268DS**

Add one or more 2-digit code(s) after the basic ordering information to select all required options

|  | XX   | XX | XX | XX | XX | XX | XX | XX | XX | XX | XX | XX | XX |
|--|------|----|----|----|----|----|----|----|----|----|----|----|----|
| <b>Drain/vent valve (material and position) (wetted parts)</b>   |      |    |    |    |    |    |    |    |    |    |    |    |    |
| AISI 316 L ss on process axis (Note 6)   | NACE | V1 |    |    |    |    |    |    |    |    |    |    |    |
| AISI 316 L ss on flange side top (Note 7)  | NACE | V2 |    |    |    |    |    |    |    |    |    |    |    |
| AISI 316 L ss on flange side bottom (Note 7)   | NACE | V3 |    |    |    |    |    |    |    |    |    |    |    |
| Hastelloy C276™ on process axis (Note 8)   | NACE | V4 |    |    |    |    |    |    |    |    |    |    |    |
| Hastelloy C276™ on flange side top (Note 9)  | NACE | V5 |    |    |    |    |    |    |    |    |    |    |    |
| Hastelloy C276™ on flange side bottom (Note 9)   | NACE | V6 |    |    |    |    |    |    |    |    |    |    |    |
| Monel 400™ on process axis (Note 10)   | NACE | V7 |    |    |    |    |    |    |    |    |    |    |    |
| Monel 400™ on flange side top (Note 11)  | NACE | V8 |    |    |    |    |    |    |    |    |    |    |    |
| Monel 400™ on flange side bottom (Note 11)   | NACE | V9 |    |    |    |    |    |    |    |    |    |    |    |
| <b>Electrical certification</b>  |      |    |    |    |    |    |    |    |    |    |    |    |    |
| ATEX Group II Category 1G and 1/2G, Category 1D and 1/2D - Intrinsic Safety Ex ia  |      | E1 |    |    |    |    |    |    |    |    |    |    |    |
| ATEX Group II Category 1/2 GD – Explosion Proof Ex d   |      | E2 |    |    |    |    |    |    |    |    |    |    |    |
| Canadian Standard Association (CSA) (only 1/2–14NPT, M20 and Pg 13.5 electrical connection)  |      | E4 |    |    |    |    |    |    |    |    |    |    |    |
| Factory Mutual (FM) approval (only with 1/2–14NPT, M20 and Pg 13.5 electrical connection)  |      | E6 |    |    |    |    |    |    |    |    |    |    |    |
| GOST (Russia) EEx ia   |      | W1 |    |    |    |    |    |    |    |    |    |    |    |
| GOST (Russia) EEx d  |      | W2 |    |    |    |    |    |    |    |    |    |    |    |
| GOST (Kazakhstan) EEx ia   |      | W3 |    |    |    |    |    |    |    |    |    |    |    |
| GOST (Kazakhstan) EEx d  |      | W4 |    |    |    |    |    |    |    |    |    |    |    |
| Inmetro (Brazil) EEx ia (pending)  |      | W5 |    |    |    |    |    |    |    |    |    |    |    |
| Inmetro (Brazil) EEx d (pending)   |      | W6 |    |    |    |    |    |    |    |    |    |    |    |
| Inmetro (Brazil) EEx nL (pending)  |      | W7 |    |    |    |    |    |    |    |    |    |    |    |
| Metrologic (Russia)  |      | WD |    |    |    |    |    |    |    |    |    |    |    |
| <b>Output meter</b>  |      |    |    |    |    |    |    |    |    |    |    |    |    |
| ProMeter, Standard calibration   |      | D1 |    |    |    |    |    |    |    |    |    |    |    |
| ProMeter, Special calibration  |      | D2 |    |    |    |    |    |    |    |    |    |    |    |
| Analog output indicator linear 0–100% scale  |      | D3 |    |    |    |    |    |    |    |    |    |    |    |
| Analog output indicator square root 0–10 scale   |      | D4 |    |    |    |    |    |    |    |    |    |    |    |
| Analog output indicator, special graduation (to be specified for linear scale)   |      | D5 |    |    |    |    |    |    |    |    |    |    |    |
| Analog output indicator, special graduation (to be specified for square root scale)  |      | D6 |    |    |    |    |    |    |    |    |    |    |    |
| Programmable signal meter and HART configurator (CoMeter)  |      | D7 |    |    |    |    |    |    |    |    |    |    |    |
| Programmable signal meter and HART configurator (CoMeter – customer configuration)   |      | D8 |    |    |    |    |    |    |    |    |    |    |    |
| <b>Mounting bracket (shape and material)</b>   |      |    |    |    |    |    |    |    |    |    |    |    |    |
| For pipe mounting (Not suitable for AISI housing) Carbon steel   |      | B1 |    |    |    |    |    |    |    |    |    |    |    |
| For pipe mounting (Not suitable for AISI housing) AISI 316 L ss  |      | B2 |    |    |    |    |    |    |    |    |    |    |    |
| For wall mounting (Not suitable for AISI housing) Carbon steel   |      | B3 |    |    |    |    |    |    |    |    |    |    |    |
| For wall mounting (Not suitable for AISI housing) AISI 316 L ss  |      | B4 |    |    |    |    |    |    |    |    |    |    |    |
| Flat type for box AISI 316 L ss  |      | B5 |    |    |    |    |    |    |    |    |    |    |    |
| <b>Surge</b>   |      |    |    |    |    |    |    |    |    |    |    |    |    |
| Surge/Transient Protector  |      | S1 |    |    |    |    |    |    |    |    |    |    |    |
| <b>Operating manual</b>  |      |    |    |    |    |    |    |    |    |    |    |    |    |
| German   |      | M1 |    |    |    |    |    |    |    |    |    |    |    |
| Italian  |      | M2 |    |    |    |    |    |    |    |    |    |    |    |
| French   |      | M4 |    |    |    |    |    |    |    |    |    |    |    |
| <b>Labels &amp; tag language</b>   |      |    |    |    |    |    |    |    |    |    |    |    |    |
| German   |      | T1 |    |    |    |    |    |    |    |    |    |    |    |
| Italian  |      | T2 |    |    |    |    |    |    |    |    |    |    |    |
| Spanish  |      | T3 |    |    |    |    |    |    |    |    |    |    |    |
| French   |      | T4 |    |    |    |    |    |    |    |    |    |    |    |
| <b>Additional tag plate</b>  |      |    |    |    |    |    |    |    |    |    |    |    |    |
| Laser printing of tag on stainless steel plate   |      | I2 |    |    |    |    |    |    |    |    |    |    |    |
| <b>Configuration</b>   |      |    |    |    |    |    |    |    |    |    |    |    |    |
| Standard – Pressure = inH <sub>2</sub> O/psi at 20° C; Temperature = deg. F  |      | N2 |    |    |    |    |    |    |    |    |    |    |    |
| Standard – Pressure = inH <sub>2</sub> O/psi at 4° C; Temperature = deg. F   |      | N3 |    |    |    |    |    |    |    |    |    |    |    |
| Standard – Pressure = inH <sub>2</sub> O/psi at 20° C; Temperature = deg.C   |      | N4 |    |    |    |    |    |    |    |    |    |    |    |
| Standard – Pressure = inH <sub>2</sub> O/psi at 4° C; Temperature = deg. C   |      | N5 |    |    |    |    |    |    |    |    |    |    |    |
| Custom   |      | N6 |    |    |    |    |    |    |    |    |    |    |    |
| <b>Preparation procedure</b>   |      |    |    |    |    |    |    |    |    |    |    |    |    |
| Oxygen service cleaning (only available with inert fill and PTFE gasket) – P <sub>max</sub> = 12MPa for Galden or 9MPa for Halocarbon; T <sub>max</sub> = 60° C/140° F |      | P1 |    |    |    |    |    |    |    |    |    |    |    |
| Hydrogen service preparation   |      | P2 |    |    |    |    |    |    |    |    |    |    |    |
| Special services preparation   |      | P4 |    |    |    |    |    |    |    |    |    |    |    |
| <b>Certificates</b>  |      |    |    |    |    |    |    |    |    |    |    |    |    |
| Inspection certificate EN 10204–3.1 of calibration (9-point)   |      | C1 |    |    |    |    |    |    |    |    |    |    |    |
| Certificate of compliance with the order EN 10204–2.1 of instrument design   |      | C6 |    |    |    |    |    |    |    |    |    |    |    |
| <b>Material traceability</b>   |      |    |    |    |    |    |    |    |    |    |    |    |    |
| Certificate of compliance with the order EN 10204–2.1 of process wetted parts  |      | H1 |    |    |    |    |    |    |    |    |    |    |    |
| Inspection certificate EN 10204–3.1 of process wetted parts  |      | H3 |    |    |    |    |    |    |    |    |    |    |    |
| <b>Connector</b>   |      |    |    |    |    |    |    |    |    |    |    |    |    |
| Harting Han – straight entry (Note 12)   |      | U3 |    |    |    |    |    |    |    |    |    |    |    |
| Harting Han – angle entry (Note 12)  |      | U4 |    |    |    |    |    |    |    |    |    |    |    |

## 2600T Pressure Transmitters

Model 268DS, 268PS, 268VS

SS/268XS\_7

- Note 1: Suitable for oxygen service
- Note 2: Not available with sensor code B
- Note 3: Not available with diaphragm material/fill fluid code S, H, A, B, L, Q
- Note 4: Select type in additional ordering code
- Note 5: Not available with Electronic Housing code P, E and K
- Note 6: Not available with Process flanges/adapters code D, E, G, H, Q, T, M, S, U, V
- Note 7: Not available with Process flanges/adapters code D, E, G, H, M, S, U, V
- Note 8: Not available with Process flanges/adapters code A, B, G, H, Q, T, M, S, U, V
- Note 9: Not available with Process flanges/adapters code A, B, G, H, Q, T, U, V
- Note 10: Not available with Process flanges/adapters code A, B, D, E, Q, T, M, S, U, V
- Note 11: Not available with Process flanges/adapters code A, B, D, E, Q, T, M, S
- Note 12: Not available with Electronic housing code U, S, T, V, H, M, L, N, D, C, A, B, J, Y

### Standard delivery items (can be differently specified by additional ordering code)

- Adapters supplied loose
- Plug on axis of horizontal connection flange; nothing for vertical connection blind flange (no drain/vent valves)
- General purpose (no electrical certification)
- No meter/display, no mounting bracket, no surge protection
- English manual and labels
- Configuration with kPa and deg. C units
- No test, inspection or material traceability certificates

THE SELECTION OF SUITABLE WETTED PARTS AND FILLING FLUID FOR COMPATIBILITY WITH THE PROCESS MEDIA IS A CUSTOMER'S RESPONSIBILITY, IF NOT OTHERWISE NOTIFIED BEFORE MANUFACTURING.

### BASIC ORDERING INFORMATION model 268PS Safety Gauge Pressure Transmitter

Select one character or set of characters from each category and specify complete catalog number.

Refer to additional ordering information code and specify one or more codes for each transmitter if additional options are required.

| BASE MODEL – 1 <sup>st</sup> to 5 <sup>th</sup> characters  |                 |   | 2 | 6 | 8 | P | S | X | S    | X        | X | X | X | X |
|---|-----------------|---|---|---|---|---|---|---|------|----------|---|---|---|---|
| Safety Gauge Pressure Transmitter – BASE ACCURACY 0.075%  |                 |   |   |   |   |   |   |   |      |          |   |   |   |   |
| <b>SENSOR - Span limits – 6<sup>th</sup> character</b>  |                 |   |   |   |   |   |   |   |      |          |   |   |   |   |
| 0.14 and 4kPa   | 1.4 and 40mbar  | 0.56 and 16inH <sub>2</sub> O   |   |   |   |   |   | B |      |          |   |   |   |   |
| 0.27 and 16kPa  | 2.7 and 160mbar | 1.08 and 64inH <sub>2</sub> O   |   |   |   |   |   | E |      |          |   |   |   |   |
| 0.4 and 40kPa   | 4 and 400mbar   | 1.6 and 160inH <sub>2</sub> O   |   |   |   |   |   | F |      |          |   |   |   |   |
| 0.65 and 65kPa  | 6.5 and 650mbar | 2.6 and 260inH <sub>2</sub> O   |   |   |   |   |   | G |      |          |   |   |   |   |
| 1.6 and 160kPa  | 16 and 1600mbar | 6.4 and 642inH <sub>2</sub> O   |   |   |   |   |   | H |      |          |   |   |   |   |
| 6 and 600kPa  | 0.06 and 6bar   | 0.87 and 87psi  |   |   |   |   |   | M |      |          |   |   |   |   |
| 24 and 2400kPa  | 0.24 and 24bar  | 3.5 and 348psi  |   |   |   |   |   | P |      |          |   |   |   |   |
| 80 and 8000kPa  | 0.8 and 80bar   | 11.6 and 1160psi  |   |   |   |   |   | Q |      |          |   |   |   |   |
| 160 and 16000kPa  | 1.6 and 160bar  | 23.2 and 2320psi  |   |   |   |   |   | S |      |          |   |   |   |   |
| <b>Use code – 7<sup>th</sup> character</b>  |                 |   |   |   |   |   |   |   | S    |          |   |   |   |   |
| <b>Diaphragm material / Fill fluid (wetted parts) – 8<sup>th</sup> character</b>                  |                 |   |   |   |   |   |   |   |      |          |   |   |   |   |
| AISI 316 L ss   |                 | Silicone oil (Note 2)   |   |   |   |   |   |   |      | S        |   |   |   |   |
| Hastelloy C276™ (on AISI seat)  |                 | Silicone oil  |   |   |   |   |   |   | NACE | H        |   |   |   |   |
| Hastelloy C276™   |                 | Silicone oil  |   |   |   |   |   |   | NACE | K        |   |   |   |   |
| Monel 400™  |                 | Silicone oil (Note 2)   |   |   |   |   |   |   | NACE | M        |   |   |   |   |
| AISI 316 L ss gold plated   |                 | Silicone oil (Note 2)   |   |   |   |   |   |   |      | 8        |   |   |   |   |
| Tantalum  |                 | Silicone oil (Note 2)   |   |   |   |   |   |   | NACE | T        |   |   |   |   |
| AISI 316 L ss   |                 | Inert fluid - Galden (Notes 1, 2)                                     |   |   |   |   |   |   |      | A        |   |   |   |   |
| Hastelloy C276™ (on AISI seat)  |                 | Inert fluid - Galden (Notes 1, 2)                                     |   |   |   |   |   |   | NACE | B        |   |   |   |   |
| Hastelloy C276™   |                 | Inert fluid - Galden (Notes 1, 2)                                     |   |   |   |   |   |   | NACE | F        |   |   |   |   |
| Monel 400™  |                 | Inert fluid - Galden (Notes 1, 2)                                     |   |   |   |   |   |   | NACE | C        |   |   |   |   |
| AISI 316 L ss gold plated   |                 | Inert fluid - Galden (Notes 1, 2)                                     |   |   |   |   |   |   |      | 9        |   |   |   |   |
| Tantalum  |                 | Inert fluid - Galden (Notes 1, 2)                                     |   |   |   |   |   |   | NACE | D        |   |   |   |   |
| AISI 316 L ss   |                 | Inert fluid - Halocarbon (Notes 1, 2)                                 |   |   |   |   |   |   |      | L        |   |   |   |   |
| Hastelloy C276™ (on AISI seat)  |                 | Inert fluid - Halocarbon (Notes 1, 2)                                 |   |   |   |   |   |   | NACE | Q        |   |   |   |   |
| Hastelloy C276™   |                 | Inert fluid - Halocarbon (Notes 1, 2)                                 |   |   |   |   |   |   | NACE | P        |   |   |   |   |
| Monel 400™  |                 | Inert fluid - Halocarbon (Notes 1, 2)                                 |   |   |   |   |   |   | NACE | 4        |   |   |   |   |
| AISI 316 L ss gold plated   |                 | Inert fluid - Halocarbon (Notes 1, 2)                                 |   |   |   |   |   |   |      | I        |   |   |   |   |
| Tantalum  |                 | Inert fluid - Halocarbon (Notes 1, 2)                                 |   |   |   |   |   |   | NACE | 5        |   |   |   |   |
| <b>Process flanges/adapters material and connection (wetted parts) – 9<sup>th</sup> character</b> |                 |   |   |   |   |   |   |   |      |          |   |   |   |   |
| AISI 316 L ss (Horizontal connection)   |                 | 1/4 – 18 NPT-f direct (7/16 – 20 UNF U.S. drilling)                   |   |   |   |   |   |   | NACE |          | A |   |   |   |
| AISI 316 L ss (Horizontal connection)   |                 | 1/2 – 14 NPT-f through adapter (7/16 – 20 UNF U.S. drilling)          |   |   |   |   |   |   | NACE |          | B |   |   |   |
| Hastelloy C276™ (Horizontal connection)   |                 | 1/4 – 18 NPT-f direct (7/16 – 20 UNF U.S. drilling) (Note 3)          |   |   |   |   |   |   | NACE |          | D |   |   |   |
| Hastelloy C276™ (Horizontal connection)   |                 | 1/2 – 14 NPT-f through adapter (7/16 – 20 UNF U.S. drilling) (Note 3) |   |   |   |   |   |   | NACE |          | E |   |   |   |
| Monel 400™ (Horizontal connection)  |                 | 1/4 – 18 NPT-f direct (7/16 – 20 UNF U.S. drilling) (Note 3)          |   |   |   |   |   |   | NACE |          | G |   |   |   |
| Monel 400™ (Horizontal connection)  |                 | 1/2 – 14 NPT-f through adapter (7/16 – 20 UNF U.S. drilling) (Note 3) |   |   |   |   |   |   | NACE |          | H |   |   |   |
| AISI 316 L ss (Vertical connection)   |                 | 1/4 – 18 NPT-f direct (7/16 – 20 UNF U.S. drilling)                   |   |   |   |   |   |   | NACE |          | Q |   |   |   |
| AISI 316 L ss (Vertical connection)   |                 | 1/2 – 14 NPT-f through adapter (7/16 – 20 UNF U.S. drilling)          |   |   |   |   |   |   | NACE |          | T |   |   |   |
| Hastelloy C276™ (Vertical connection)   |                 | 1/4 – 18 NPT-f direct (7/16 – 20 UNF U.S. drilling) (Note 3)          |   |   |   |   |   |   | NACE |          | M |   |   |   |
| Hastelloy C276™ (Vertical connection)   |                 | 1/2 – 14 NPT-f through adapter (7/16 – 20 UNF U.S. drilling) (Note 3) |   |   |   |   |   |   | NACE |          | S |   |   |   |
| Monel 400™ (Vertical connection)  |                 | 1/4 – 18 NPT-f direct (7/16 – 20 UNF U.S. drilling) (Note 3)          |   |   |   |   |   |   | NACE |          | U |   |   |   |
| Monel 400™ (Vertical connection)  |                 | 1/2 – 14 NPT-f through adapter (7/16 – 20 UNF U.S. drilling) (Note 3) |   |   |   |   |   |   | NACE |          | V |   |   |   |
| <b>Bolts/Gasket (wetted parts) – 10<sup>th</sup> character</b>                                    |                 |   |   |   |   |   |   |   |      |          |   |   |   |   |
| AISI 316 ss   |                 | Viton™  |   |   |   |   |   |   |      |          |   |   |   | 1 |
| AISI 316 ss   |                 | PTFE (Note 1)   |   |   |   |   |   |   |      |          |   |   |   | 2 |
| AISI 316 ss (NACE) – (MWP = 16MPa)  |                 | Viton™  |   |   |   |   |   |   | NACE |          |   |   |   | 3 |
| AISI 316 ss (NACE) – (MWP = 16MPa)  |                 | PTFE (Note 1)   |   |   |   |   |   |   | NACE |          |   |   |   | 4 |
| Alloy steel (NACE)  |                 | Viton™  |   |   |   |   |   |   | NACE |          |   |   |   | 8 |
| Alloy steel (NACE)  |                 | PTFE (Note 1)   |   |   |   |   |   |   | NACE |          |   |   |   | 9 |
| <b>Housing material and electrical connection – 11<sup>th</sup> character</b>                     |                 |   |   |   |   |   |   |   |      |          |   |   |   |   |
| Aluminium alloy (Barrel version)  |                 | 1/2 – 14 NPT  |   |   |   |   |   |   |      |          |   |   |   | A |
| Aluminium alloy (Barrel version)  |                 | M20 x 1.5 (CM 20)   |   |   |   |   |   |   |      |          |   |   |   | B |
| Aluminium alloy (Barrel version)  |                 | Pg 13.5   |   |   |   |   |   |   |      |          |   |   |   | D |
| Aluminium alloy (Barrel version)  |                 | 1/2 GK  |   |   |   |   |   |   |      |          |   |   |   | C |
| Aluminium alloy (Barrel version)  |                 | Harting Han connector (general purpose only) (Note 4)                 |   |   |   |   |   |   |      |          |   |   |   | E |
| Aluminium alloy copper-free (Barrel version)  |                 | 1/2 – 14 NPT  |   |   |   |   |   |   |      |          |   |   |   | H |
| Aluminium alloy copper-free (Barrel version)  |                 | M20 x 1.5 (CM 20)   |   |   |   |   |   |   |      |          |   |   |   | L |
| Aluminium alloy copper-free (Barrel version)  |                 | Pg 13.5   |   |   |   |   |   |   |      |          |   |   |   | N |
| Aluminium alloy copper-free (Barrel version)  |                 | 1/2 GK  |   |   |   |   |   |   |      |          |   |   |   | M |
| Aluminium alloy copper-free (Barrel version)  |                 | Harting Han connector (general purpose only) (Note 4)                 |   |   |   |   |   |   |      |          |   |   |   | P |
| AISI 316 L ss (Barrel version)  |                 | 1/2 – 14 NPT  |   |   |   |   |   |   |      |          |   |   |   | S |
| AISI 316 L ss (Barrel version)  |                 | M20 x 1.5 (CM20)  |   |   |   |   |   |   |      |          |   |   |   | T |
| AISI 316 L ss (Barrel version)  |                 | Pg 13.5   |   |   |   |   |   |   |      |          |   |   |   | V |
| AISI 316 L ss (Barrel version)  |                 | 1/2 GK  |   |   |   |   |   |   |      |          |   |   |   | U |
| Aluminium alloy (DIN version)   |                 | M20 x 1.5 (CM 20) (general purpose only)                              |   |   |   |   |   |   |      |          |   |   |   | J |
| Aluminium alloy (DIN version)   |                 | Pg 13.5 (general purpose only)  |   |   |   |   |   |   |      |          |   |   |   | Y |
| Aluminium alloy (DIN version)   |                 | Harting Han connector (general purpose only) (Note 4)                 |   |   |   |   |   |   |      |          |   |   |   | K |
| <b>Output/Additional options – 12<sup>th</sup> character</b>                                      |                 |   |   |   |   |   |   |   |      |          |   |   |   |   |
| HART digital communication and 4 to 20mA (SIL 2)  |                 | No additional options   |   |   |   |   |   |   |      | (Note 5) |   |   |   | T |
| HART digital communication and 4 to 20mA (SIL 2)  |                 | Options requested (to be ordered by "Additional ordering code")       |   |   |   |   |   |   |      |          |   |   |   | 8 |

**ADDITIONAL ORDERING INFORMATION for model 268PS**

Add one or more 2-digit code(s) after the basic ordering information to select all required options

|  | XX   | XX | XX | XX | XX | XX | XX | XX | XX | XX | XX | XX | XX | XX |
|--|------|----|----|----|----|----|----|----|----|----|----|----|----|----|
| <b>Drain/vent valve (material and position) (wetted parts)</b>   |      |    |    |    |    |    |    |    |    |    |    |    |    |    |
| AISI 316 L ss on process axis (Note 6)   | NACE | V1 |    |    |    |    |    |    |    |    |    |    |    |    |
| AISI 316 L ss on flange side top (Note 7)  | NACE | V2 |    |    |    |    |    |    |    |    |    |    |    |    |
| AISI 316 L ss on flange side bottom (Note 7)   | NACE | V3 |    |    |    |    |    |    |    |    |    |    |    |    |
| Hastelloy C276™ on process axis (Note 8)   | NACE | V4 |    |    |    |    |    |    |    |    |    |    |    |    |
| Hastelloy C276™ on flange side top (Note 9)  | NACE | V5 |    |    |    |    |    |    |    |    |    |    |    |    |
| Hastelloy C276™ on flange side bottom (Note 9)   | NACE | V6 |    |    |    |    |    |    |    |    |    |    |    |    |
| Monel 400™ on process axis (Note 10)   | NACE | V7 |    |    |    |    |    |    |    |    |    |    |    |    |
| Monel 400™ on flange side top (Note 11)  | NACE | V8 |    |    |    |    |    |    |    |    |    |    |    |    |
| Monel 400™ on flange side bottom (Note 11)   | NACE | V9 |    |    |    |    |    |    |    |    |    |    |    |    |
| <b>Electrical certification</b>  |      |    |    |    |    |    |    |    |    |    |    |    |    |    |
| ATEX Group II Category 1G and 1/2G, Category 1D and 1/2D - Intrinsic Safety Ex ia  |      | E1 |    |    |    |    |    |    |    |    |    |    |    |    |
| ATEX Group II Category 1/2 GD – Explosion Proof Ex d   |      | E2 |    |    |    |    |    |    |    |    |    |    |    |    |
| Canadian Standard Association (CSA) (only 1/2–14NPT, M20 and Pg 13.5 electrical connection)  |      | E4 |    |    |    |    |    |    |    |    |    |    |    |    |
| Factory Mutual (FM) approval (only with 1/2–14NPT, M20 and Pg 13.5 electrical connection)  |      | E6 |    |    |    |    |    |    |    |    |    |    |    |    |
| GOST (Russia) EEx ia   |      | W1 |    |    |    |    |    |    |    |    |    |    |    |    |
| GOST (Russia) EEx d  |      | W2 |    |    |    |    |    |    |    |    |    |    |    |    |
| GOST (Kazakistan) EEx ia   |      | W3 |    |    |    |    |    |    |    |    |    |    |    |    |
| GOST (Kazakistan) EEx d  |      | W4 |    |    |    |    |    |    |    |    |    |    |    |    |
| Inmetro (Brazil) EEx ia (pending)  |      | W5 |    |    |    |    |    |    |    |    |    |    |    |    |
| Inmetro (Brazil) EEx d (pending)   |      | W6 |    |    |    |    |    |    |    |    |    |    |    |    |
| Inmetro (Brazil) EEx nL (pending)  |      | W7 |    |    |    |    |    |    |    |    |    |    |    |    |
| Metrologic (Russia)  |      | WD |    |    |    |    |    |    |    |    |    |    |    |    |
| <b>Output meter</b>  |      |    |    |    |    |    |    |    |    |    |    |    |    |    |
| ProMeter, Standard calibration   |      | D1 |    |    |    |    |    |    |    |    |    |    |    |    |
| ProMeter, Special calibration  |      | D2 |    |    |    |    |    |    |    |    |    |    |    |    |
| Analog output indicator linear 0–100% scale  |      | D3 |    |    |    |    |    |    |    |    |    |    |    |    |
| Analog output indicator, special graduation (to be specified for linear scale)   |      | D5 |    |    |    |    |    |    |    |    |    |    |    |    |
| Programmable signal meter and HART configurator (CoMeter)  |      | D7 |    |    |    |    |    |    |    |    |    |    |    |    |
| Programmable signal meter and HART configurator (CoMeter – customer configuration)   |      | D8 |    |    |    |    |    |    |    |    |    |    |    |    |
| <b>Mounting bracket (shape and material)</b>   |      |    |    |    |    |    |    |    |    |    |    |    |    |    |
| For pipe mounting (Not suitable for AISI housing) Carbon steel   |      | B1 |    |    |    |    |    |    |    |    |    |    |    |    |
| For pipe mounting (Not suitable for AISI housing) AISI 316 L ss  |      | B2 |    |    |    |    |    |    |    |    |    |    |    |    |
| For wall mounting (Not suitable for AISI housing) Carbon steel   |      | B3 |    |    |    |    |    |    |    |    |    |    |    |    |
| For wall mounting (Not suitable for AISI housing) AISI 316 L ss  |      | B4 |    |    |    |    |    |    |    |    |    |    |    |    |
| Flat type for box AISI 316 L ss  |      | B5 |    |    |    |    |    |    |    |    |    |    |    |    |
| <b>Surge</b>   |      |    |    |    |    |    |    |    |    |    |    |    |    |    |
| Surge/Transient Protector  |      |    |    |    |    |    |    | S1 |    |    |    |    |    |    |
| <b>Operating manual</b>  |      |    |    |    |    |    |    |    |    |    |    |    |    |    |
| German   |      |    |    |    |    |    |    |    |    | M1 |    |    |    |    |
| Italian  |      |    |    |    |    |    |    |    |    | M2 |    |    |    |    |
| French   |      |    |    |    |    |    |    |    |    | M4 |    |    |    |    |
| <b>Labels &amp; tag language</b>   |      |    |    |    |    |    |    |    |    |    |    |    |    |    |
| German   |      |    |    |    |    |    |    |    |    |    |    | T1 |    |    |
| Italian  |      |    |    |    |    |    |    |    |    |    |    | T2 |    |    |
| Spanish  |      |    |    |    |    |    |    |    |    |    |    | T3 |    |    |
| French   |      |    |    |    |    |    |    |    |    |    |    | T4 |    |    |
| <b>Additional tag plate</b>  |      |    |    |    |    |    |    |    |    |    |    |    |    |    |
| Laser printing of tag on stainless steel plate   |      |    |    |    |    |    |    |    |    |    |    |    | I2 |    |
| <b>Configuration</b>   |      |    |    |    |    |    |    |    |    |    |    |    |    |    |
| Standard – Pressure = inH <sub>2</sub> O/psi at 20° C; Temperature = deg. F  |      |    |    |    |    |    |    |    |    |    |    |    |    | N2 |
| Standard – Pressure = inH <sub>2</sub> O/psi at 4° C; Temperature = deg. F   |      |    |    |    |    |    |    |    |    |    |    |    |    | N3 |
| Standard – Pressure = inH <sub>2</sub> O/psi at 20° C; Temperature = deg.C   |      |    |    |    |    |    |    |    |    |    |    |    |    | N4 |
| Standard – Pressure = inH <sub>2</sub> O/psi at 4° C; Temperature = deg. C   |      |    |    |    |    |    |    |    |    |    |    |    |    | N5 |
| Custom   |      |    |    |    |    |    |    |    |    |    |    |    |    | N6 |
| <b>Preparation procedure</b>   |      |    |    |    |    |    |    |    |    |    |    |    |    |    |
| Oxygen service cleaning (only available with inert fill and PTFE gasket) – P <sub>max</sub> = 12MPa for Galden or 9MPa for Halocarbon; T <sub>max</sub> = 60° C/140° F |      |    |    |    |    |    |    |    |    |    |    |    |    | P1 |
| Hydrogen service preparation   |      |    |    |    |    |    |    |    |    |    |    |    |    | P2 |
| Special services preparation   |      |    |    |    |    |    |    |    |    |    |    |    |    | P4 |
| <b>Certificates</b>  |      |    |    |    |    |    |    |    |    |    |    |    |    |    |
| Inspection certificate EN 10204–3.1 of calibration (9-point)   |      |    |    |    |    |    |    |    |    |    |    |    |    | C1 |
| Certificate of compliance with the order EN 10204–2.1 of instrument design   |      |    |    |    |    |    |    |    |    |    |    |    |    | C6 |
| <b>Material traceability</b>   |      |    |    |    |    |    |    |    |    |    |    |    |    |    |
| Certificate of compliance with the order EN 10204–2.1 of process wetted parts  |      |    |    |    |    |    |    |    |    |    |    |    |    | H1 |
| Inspection certificate EN 10204–3.1 of process wetted parts  |      |    |    |    |    |    |    |    |    |    |    |    |    | H3 |
| <b>Connector</b>   |      |    |    |    |    |    |    |    |    |    |    |    |    |    |
| Harting Han – straight entry (Note 12)   |      |    |    |    |    |    |    |    |    |    |    |    |    | U3 |
| Harting Han – angle entry (Note 12)  |      |    |    |    |    |    |    |    |    |    |    |    |    | U4 |

- Note 1: Suitable for oxygen service
- Note 2: Not available with sensor code B
- Note 3: Not available with diaphragm material/fill fluid code S, H, A, B, L, Q
- Note 4: Select type in additional ordering code
- Note 5: Not available with Electronic Housing code P, E and K
- Note 6: Not available with Process flanges/adapters code D, E, G, H, Q, T, M, S, U, V
- Note 7: Not available with Process flanges/adapters code D, E, G, H, M, S, U, V
- Note 8: Not available with Process flanges/adapters code A, B, G, H, Q, T, M, S, U, V
- Note 9: Not available with Process flanges/adapters code A, B, G, H, Q, T, U, V
- Note 10: Not available with Process flanges/adapters code A, B, D, E, Q, T, M, S, U, V
- Note 11: Not available with Process flanges/adapters code A, B, D, E, Q, T, M, S
- Note 12: Not available with Electronic housing code U, S, T, V, H, M, L, N, D, C, A, B, J, Y

**Standard delivery items (can be differently specified by additional ordering code)**

- Adapters supplied loose
- Plug on axis of horizontal connection flange; nothing for vertical connection blind flange (no drain/vent valves)
- General purpose (no electrical certification)
- No meter/display, no mounting bracket, no surge protection
- English manual and labels
- Configuration with kPa and deg. C units
- No test, inspection or material traceability certificates

THE SELECTION OF SUITABLE WETTED PARTS AND FILLING FLUID FOR COMPATIBILITY WITH THE PROCESS MEDIA IS A CUSTOMER'S RESPONSIBILITY, IF NOT OTHERWISE NOTIFIED BEFORE MANUFACTURING.

**BASIC ORDERING INFORMATION model 268VS Safety Absolute Pressure Transmitter**

Select one character or set of characters from each category and specify complete catalog number.  
 Refer to additional ordering information code and specify one or more codes for each transmitter if additional options are required.

| BASE MODEL – 1 <sup>st</sup> to 5 <sup>th</sup> characters  |                   |  | 2                      | 6 | 8 | V | S | X        | S    | X | X | X | X | X |
|---|-------------------|--|------------------------|---|---|---|---|----------|------|---|---|---|---|---|
| Safety Absolute Pressure Transmitter - BASE ACCURACY 0.075%                                       |                   |  |                        |   |   |   |   |          |      |   |   |   |   |   |
| <b>SENSOR – Span limits – 6th character</b>   |                   |  |                        |   |   |   |   |          |      |   |   |   |   |   |
| 0.27 and 16kPa  | 2.7 and 160mbar   | 2 and 120mmHg  |                        |   |   |   |   |          | E    |   |   |   |   |   |
| 0.67 and 40kPa  | 6.7 and 400mbar   | 5 and 300mmHg  |                        |   |   |   |   |          | F    |   |   |   |   |   |
| 1.1 and 65kPa   | 11 and 650mbar    | 8 and 480mmHg  |                        |   |   |   |   |          | G    |   |   |   |   |   |
| 2.67 and 160kPa   | 26.7 and 1600mbar | 20 and 1200mmHg  |                        |   |   |   |   |          | H    |   |   |   |   |   |
| 10 and 600kPa   | 0.1 and 6bar      | 1.45 and 87psi   |                        |   |   |   |   |          | M    |   |   |   |   |   |
| 40 and 2400kPa  | 0.4 and 24bar     | 5.8 and 348psi   |                        |   |   |   |   |          | P    |   |   |   |   |   |
| 134 and 8000kPa   | 1.34 and 80bar    | 19.4 and 1160psi   |                        |   |   |   |   |          | Q    |   |   |   |   |   |
| 267 and 16000kPa  | 2.67 and 160bar   | 38.7 and 2320psi   |                        |   |   |   |   |          | S    |   |   |   |   |   |
| <b>Use code – 7<sup>th</sup> character</b>  |                   |  |                        |   |   |   |   |          |      | S |   |   |   |   |
| <b>Diaphragm material / Fill fluid (wetted parts) – 8<sup>th</sup> character</b>                  |                   |  |                        |   |   |   |   |          |      |   |   |   |   |   |
| AISI 316 L ss   |                   | Silicone oil   |                        |   |   |   |   |          |      |   |   |   |   | S |
| Hastelloy C276™ (on AISI seat)  |                   | Silicone oil   |                        |   |   |   |   |          | NACE |   |   |   |   | H |
| Hastelloy C276™   |                   | Silicone oil   |                        |   |   |   |   |          | NACE |   |   |   |   | K |
| AISI 316 L ss   |                   | Inert fluid - Galden   | (Notes 1, 2)           |   |   |   |   |          |      |   |   |   |   | A |
| Hastelloy C276™ (on AISI seat)  |                   | Inert fluid - Galden   | (Notes 1, 2)           |   |   |   |   |          | NACE |   |   |   |   | B |
| Hastelloy C276™   |                   | Inert fluid - Galden   | (Notes 1, 2)           |   |   |   |   |          | NACE |   |   |   |   | F |
| AISI 316 L ss   |                   | Inert fluid - Halocarbon                                       | (Notes 1, 2)           |   |   |   |   |          |      |   |   |   |   | L |
| Hastelloy C276™ (on AISI seat)  |                   | Inert fluid - Halocarbon                                       | (Notes 1, 2)           |   |   |   |   |          | NACE |   |   |   |   | Q |
| Hastelloy C276™   |                   | Inert fluid - Halocarbon                                       | (Notes 1, 2)           |   |   |   |   |          | NACE |   |   |   |   | P |
| <b>Process flanges/adapters material and connection (wetted parts) – 9<sup>th</sup> character</b> |                   |  |                        |   |   |   |   |          |      |   |   |   |   |   |
| AISI 316 L ss (Horizontal connection)   |                   | 1/4 – 18 NPT-f direct (7/16 - 20 UNF U.S. drilling)            |                        |   |   |   |   |          | NACE |   |   |   |   | A |
| AISI 316 L ss (Horizontal connection)   |                   | 1/2 – 14 NPT-f through adapter (7/16 - 20 UNF U.S. drilling)   |                        |   |   |   |   |          | NACE |   |   |   |   | B |
| Hastelloy C276™ (Horizontal connection)   |                   | 1/4 – 18 NPT-f direct (7/16 - 20 UNF U.S. drilling)            | (Note 3)               |   |   |   |   |          | NACE |   |   |   |   | D |
| Hastelloy C276™ (Horizontal connection)   |                   | 1/2 – 14 NPT-f through adapter (7/16 - 20 UNF U.S. drilling)   | (Note 3)               |   |   |   |   |          | NACE |   |   |   |   | E |
| Monel 400™ (Horizontal connection)  |                   | 1/4 – 18 NPT-f direct (7/16 - 20 UNF U.S. drilling)            | (Note 3)               |   |   |   |   |          | NACE |   |   |   |   | G |
| Monel 400™ (Horizontal connection)  |                   | 1/2 – 14 NPT-f through adapter (7/16 - 20 UNF U.S. drilling)   | (Note 3)               |   |   |   |   |          | NACE |   |   |   |   | H |
| AISI 316 L ss (Vertical connection)   |                   | 1/4 – 18 NPT-f direct (7/16 - 20 UNF U.S. drilling)            |                        |   |   |   |   |          | NACE |   |   |   |   | Q |
| AISI 316 L ss (Vertical connection)   |                   | 1/2 – 14 NPT-f through adapter (7/16 - 20 UNF U.S. drilling)   |                        |   |   |   |   |          | NACE |   |   |   |   | T |
| Hastelloy C276™ (Vertical connection)   |                   | 1/4 – 18 NPT-f direct (7/16 - 20 UNF U.S. drilling)            | (Note 3)               |   |   |   |   |          | NACE |   |   |   |   | M |
| Hastelloy C276™ (Vertical connection)   |                   | 1/2 – 14 NPT-f through adapter (7/16 - 20 UNF U.S. drilling)   | (Note 3)               |   |   |   |   |          | NACE |   |   |   |   | S |
| Monel 400™ (Vertical connection)  |                   | 1/4 – 18 NPT-f direct (7/16 - 20 UNF U.S. drilling)            | (Note 3)               |   |   |   |   |          | NACE |   |   |   |   | U |
| Monel 400™ (Vertical connection)  |                   | 1/2 – 14 NPT-f through adapter (7/16 - 20 UNF U.S. drilling)   | (Note 3)               |   |   |   |   |          | NACE |   |   |   |   | V |
| <b>Bolts/Gasket (wetted parts) – 10<sup>th</sup> character</b>                                    |                   |  |                        |   |   |   |   |          |      |   |   |   |   |   |
| AISI 316 ss   |                   | Viton™   |                        |   |   |   |   |          |      |   |   |   |   | 1 |
| AISI 316 ss   |                   | PTFE   | (Note 1)               |   |   |   |   |          |      |   |   |   |   | 2 |
| AISI 316 ss (NACE) – (MWP = 16MPa)  |                   | Viton™   |                        |   |   |   |   |          | NACE |   |   |   |   | 3 |
| AISI 316 ss (NACE) – (MWP = 16MPa)  |                   | PTFE   | (Note 1)               |   |   |   |   |          | NACE |   |   |   |   | 4 |
| Alloy steel (NACE)  |                   | Viton™   |                        |   |   |   |   |          | NACE |   |   |   |   | 8 |
| Alloy steel (NACE)  |                   | PTFE   | (Note 1)               |   |   |   |   |          | NACE |   |   |   |   | 9 |
| <b>Housing material and electrical connection – 11<sup>th</sup> character</b>                     |                   |  |                        |   |   |   |   |          |      |   |   |   |   |   |
| Aluminium alloy (Barrel version)  |                   | 1/2 – 14 NPT   |                        |   |   |   |   |          |      |   |   |   |   | A |
| Aluminium alloy (Barrel version)  |                   | M20 x 1.5 (CM 20)  |                        |   |   |   |   |          |      |   |   |   |   | B |
| Aluminium alloy (Barrel version)  |                   | Pg 13.5  |                        |   |   |   |   |          |      |   |   |   |   | D |
| Aluminium alloy (Barrel version)  |                   | 1/2 GK   |                        |   |   |   |   |          |      |   |   |   |   | C |
| Aluminium alloy (Barrel version)  |                   | Harting Han connector  | (general purpose only) |   |   |   |   | (Note 4) |      |   |   |   |   | E |
| Aluminium alloy copper-free (Barrel version)  |                   | 1/2 – 14 NPT   |                        |   |   |   |   |          |      |   |   |   |   | H |
| Aluminium alloy copper-free (Barrel version)  |                   | M20 x 1.5 (CM 20)  |                        |   |   |   |   |          |      |   |   |   |   | L |
| Aluminium alloy copper-free (Barrel version)  |                   | Pg 13.5  |                        |   |   |   |   |          |      |   |   |   |   | N |
| Aluminium alloy copper-free (Barrel version)  |                   | 1/2 GK   |                        |   |   |   |   |          |      |   |   |   |   | M |
| Aluminium alloy copper-free (Barrel version)  |                   | Harting Han connector  | (general purpose only) |   |   |   |   | (Note 4) |      |   |   |   |   | P |
| AISI 316 L ss (Barrel version)  |                   | 1/2 – 14 NPT   |                        |   |   |   |   |          |      |   |   |   |   | S |
| AISI 316 L ss (Barrel version)  |                   | M20 x 1.5 (CM20)   |                        |   |   |   |   |          |      |   |   |   |   | T |
| AISI 316 L ss (Barrel version)  |                   | Pg 13.5  |                        |   |   |   |   |          |      |   |   |   |   | V |
| AISI 316 L ss (Barrel version)  |                   | 1/2 GK   |                        |   |   |   |   |          |      |   |   |   |   | U |
| Aluminium alloy (DIN version)   |                   | M20 x 1.5 (CM 20)  | (general purpose only) |   |   |   |   |          |      |   |   |   |   | J |
| Aluminium alloy (DIN version)   |                   | Pg 13.5  | (general purpose only) |   |   |   |   |          |      |   |   |   |   | Y |
| Aluminium alloy (DIN version)   |                   | Harting Han connector  | (general purpose only) |   |   |   |   | (Note 4) |      |   |   |   |   | K |
| <b>Output/Additional options – 12<sup>th</sup> character</b>                                      |                   |  |                        |   |   |   |   |          |      |   |   |   |   |   |
| HART digital communication and 4 to 20mA (SIL 2)  |                   | No additional options  |                        |   |   |   |   | (Note 5) |      |   |   |   |   | T |
| HART digital communication and 4 to 20mA (SIL 2)  |                   | Options requested (to be ordered by "Additional ordering code) |                        |   |   |   |   |          |      |   |   |   |   | 8 |

**ADDITIONAL ORDERING INFORMATION for model 268VS**

Add one or more 2-digit code(s) after the basic ordering information to select all required options

|  | XX   | XX | XX | XX | XX | XX | XX | XX | XX | XX | XX | XX | XX | XX |
|--|------|----|----|----|----|----|----|----|----|----|----|----|----|----|
| <b>Drain/vent valve (material and position) (wetted parts)</b>   |      |    |    |    |    |    |    |    |    |    |    |    |    |    |
| AISI 316 L ss on process axis (Note 6)   | NACE | V1 |    |    |    |    |    |    |    |    |    |    |    |    |
| AISI 316 L ss on flange side top (Note 7)  | NACE | V2 |    |    |    |    |    |    |    |    |    |    |    |    |
| AISI 316 L ss on flange side bottom (Note 7)   | NACE | V3 |    |    |    |    |    |    |    |    |    |    |    |    |
| Hastelloy C276™ on process axis (Note 8)   | NACE | V4 |    |    |    |    |    |    |    |    |    |    |    |    |
| Hastelloy C276™ on flange side top (Note 9)  | NACE | V5 |    |    |    |    |    |    |    |    |    |    |    |    |
| Hastelloy C276™ on flange side bottom (Note 9)   | NACE | V6 |    |    |    |    |    |    |    |    |    |    |    |    |
| Monel 400™ on process axis (Note 10)   | NACE | V7 |    |    |    |    |    |    |    |    |    |    |    |    |
| Monel 400™ on flange side top (Note 11)  | NACE | V8 |    |    |    |    |    |    |    |    |    |    |    |    |
| Monel 400™ on flange side bottom (Note 11)   | NACE | V9 |    |    |    |    |    |    |    |    |    |    |    |    |
| <b>Electrical certification</b>  |      |    |    |    |    |    |    |    |    |    |    |    |    |    |
| ATEX Group II Category 1G and 1/2G, Category 1D and 1/2D - Intrinsic Safety Ex ia  |      | E1 |    |    |    |    |    |    |    |    |    |    |    |    |
| ATEX Group II Category 1/2 GD – Explosion Proof Ex d   |      | E2 |    |    |    |    |    |    |    |    |    |    |    |    |
| Canadian Standard Association (CSA) (only 1/2–14NPT, M20 and Pg 13.5 electrical connection)  |      | E4 |    |    |    |    |    |    |    |    |    |    |    |    |
| Factory Mutual (FM) approval (only with 1/2–14NPT, M20 and Pg 13.5 electrical connection)  |      | E6 |    |    |    |    |    |    |    |    |    |    |    |    |
| GOST (Russia) EEx ia   |      | W1 |    |    |    |    |    |    |    |    |    |    |    |    |
| GOST (Russia) EEx d  |      | W2 |    |    |    |    |    |    |    |    |    |    |    |    |
| GOST (Kazakhstan) EEx ia   |      | W3 |    |    |    |    |    |    |    |    |    |    |    |    |
| GOST (Kazakhstan) EEx d  |      | W4 |    |    |    |    |    |    |    |    |    |    |    |    |
| Inmetro (Brazil) EEx ia (pending)  |      | W5 |    |    |    |    |    |    |    |    |    |    |    |    |
| Inmetro (Brazil) EEx d (pending)   |      | W6 |    |    |    |    |    |    |    |    |    |    |    |    |
| Inmetro (Brazil) EEx nL (pending)  |      | W7 |    |    |    |    |    |    |    |    |    |    |    |    |
| Metrologic (Russia)  |      | WD |    |    |    |    |    |    |    |    |    |    |    |    |
| <b>Output meter</b>  |      |    |    |    |    |    |    |    |    |    |    |    |    |    |
| ProMeter, Standard calibration   |      | D1 |    |    |    |    |    |    |    |    |    |    |    |    |
| ProMeter, Special calibration  |      | D2 |    |    |    |    |    |    |    |    |    |    |    |    |
| Analog output indicator linear 0–100% scale  |      | D3 |    |    |    |    |    |    |    |    |    |    |    |    |
| Analog output indicator, special graduation (to be specified for linear scale)   |      | D5 |    |    |    |    |    |    |    |    |    |    |    |    |
| Programmable signal meter and HART configurator (CoMeter)  |      | D7 |    |    |    |    |    |    |    |    |    |    |    |    |
| Programmable signal meter and HART configurator (CoMeter – customer configuration)   |      | D8 |    |    |    |    |    |    |    |    |    |    |    |    |
| <b>Mounting bracket (shape and material)</b>   |      |    |    |    |    |    |    |    |    |    |    |    |    |    |
| For pipe mounting (Not suitable for AISI housing) Carbon steel   |      | B1 |    |    |    |    |    |    |    |    |    |    |    |    |
| For pipe mounting (Not suitable for AISI housing) AISI 316 L ss  |      | B2 |    |    |    |    |    |    |    |    |    |    |    |    |
| For wall mounting (Not suitable for AISI housing) Carbon steel   |      | B3 |    |    |    |    |    |    |    |    |    |    |    |    |
| For wall mounting (Not suitable for AISI housing) AISI 316 L ss  |      | B4 |    |    |    |    |    |    |    |    |    |    |    |    |
| Flat type for box AISI 316 L ss  |      | B5 |    |    |    |    |    |    |    |    |    |    |    |    |
| <b>Surge</b>   |      |    |    |    |    |    |    |    |    |    |    |    |    |    |
| Surge/Transient Protector  |      | S1 |    |    |    |    |    |    |    |    |    |    |    |    |
| <b>Operating manual</b>  |      |    |    |    |    |    |    |    |    |    |    |    |    |    |
| German   |      | M1 |    |    |    |    |    |    |    |    |    |    |    |    |
| Italian  |      | M2 |    |    |    |    |    |    |    |    |    |    |    |    |
| French   |      | M4 |    |    |    |    |    |    |    |    |    |    |    |    |
| <b>Labels &amp; tag language</b>   |      |    |    |    |    |    |    |    |    |    |    |    |    |    |
| German   |      | T1 |    |    |    |    |    |    |    |    |    |    |    |    |
| Italian  |      | T2 |    |    |    |    |    |    |    |    |    |    |    |    |
| Spanish  |      | T3 |    |    |    |    |    |    |    |    |    |    |    |    |
| French   |      | T4 |    |    |    |    |    |    |    |    |    |    |    |    |
| <b>Additional tag plate</b>  |      |    |    |    |    |    |    |    |    |    |    |    |    |    |
| Laser printing of tag on stainless steel plate   |      | I2 |    |    |    |    |    |    |    |    |    |    |    |    |
| <b>Configuration</b>   |      |    |    |    |    |    |    |    |    |    |    |    |    |    |
| Standard – Pressure = inH <sub>2</sub> O/psi at 20° C; Temperature = deg. F  |      | N2 |    |    |    |    |    |    |    |    |    |    |    |    |
| Standard – Pressure = inH <sub>2</sub> O/psi at 4° C; Temperature = deg. F   |      | N3 |    |    |    |    |    |    |    |    |    |    |    |    |
| Standard – Pressure = inH <sub>2</sub> O/psi at 20° C; Temperature = deg. C  |      | N4 |    |    |    |    |    |    |    |    |    |    |    |    |
| Standard – Pressure = inH <sub>2</sub> O/psi at 4° C; Temperature = deg. C   |      | N5 |    |    |    |    |    |    |    |    |    |    |    |    |
| Custom   |      | N6 |    |    |    |    |    |    |    |    |    |    |    |    |
| <b>Preparation procedure</b>   |      |    |    |    |    |    |    |    |    |    |    |    |    |    |
| Oxygen service cleaning (only available with inert fill and PTFE gasket) - P <sub>max</sub> = 12MPa for Galden or 9MPa for Halocarbon; T <sub>max</sub> = 60° C/140° F |      | P1 |    |    |    |    |    |    |    |    |    |    |    |    |
| Hydrogen service preparation   |      | P2 |    |    |    |    |    |    |    |    |    |    |    |    |
| Special services preparation   |      | P4 |    |    |    |    |    |    |    |    |    |    |    |    |
| <b>Certificates</b>  |      |    |    |    |    |    |    |    |    |    |    |    |    |    |
| Inspection certificate EN 10204–3.1 of calibration (9-point)   |      | C1 |    |    |    |    |    |    |    |    |    |    |    |    |
| Certificate of compliance with the order EN 10204–2.1 of instrument design   |      | C6 |    |    |    |    |    |    |    |    |    |    |    |    |
| <b>Material traceability</b>   |      |    |    |    |    |    |    |    |    |    |    |    |    |    |
| Certificate of compliance with the order EN 10204–2.1 of process wetted parts  |      | H1 |    |    |    |    |    |    |    |    |    |    |    |    |
| Inspection certificate EN 10204–3.1 of process wetted parts  |      | H3 |    |    |    |    |    |    |    |    |    |    |    |    |
| <b>Connector</b>   |      |    |    |    |    |    |    |    |    |    |    |    |    |    |
| Harting Han – straight entry (Note 12)   |      | U3 |    |    |    |    |    |    |    |    |    |    |    |    |
| Harting Han – angle entry (Note 12)  |      | U4 |    |    |    |    |    |    |    |    |    |    |    |    |

- Note 1: Suitable for oxygen service
- Note 2: Not available with sensor code E
- Note 3: Not available with diaphragm material/fill fluid code S, H, A, B, L, Q
- Note 4: Select type in additional ordering code
- Note 5: Not available with Electronic Housing code P, E and K
- Note 6: Not available with Process flanges/adapters code D, E, G, H, Q, T, M, S, U, V
- Note 7: Not available with Process flanges/adapters code D, E, G, H, M, S, U, V
- Note 8: Not available with Process flanges/adapters code A, B, G, H, Q, T, M, S, U, V
- Note 9: Not available with Process flanges/adapters code A, B, G, H, Q, T, U, V
- Note 10: Not available with Process flanges/adapters code A, B, D, E, Q, T, M, S, U, V
- Note 11: Not available with Process flanges/adapters code A, B, D, E, Q, T, M, S
- Note 12: Not available with Electronic housing code U, S, T, V, H, M, L, N, D, C, A, B, J, Y

**Standard delivery items (can be differently specified by additional ordering code)**

- Adapters supplied loose
- Plug on axis of horizontal connection flange; nothing for vertical connection blind flange (no drain/vent valves)
- General purpose (no electrical certification)
- No meter/display, no mounting bracket, no surge protection
- English manual and labels
- Configuration with kPa and deg. C units
- No test, inspection or material traceability certificates

THE SELECTION OF SUITABLE WETTED PARTS AND FILLING FLUID FOR COMPATIBILITY WITH THE PROCESS MEDIA IS A CUSTOMER'S RESPONSIBILITY, IF NOT OTHERWISE NOTIFIED BEFORE MANUFACTURING.

™ Hastelloy C276 is a Cabot Corporation trademark

™ Hastelloy C2000 is an Haynes International trademark

™ Monel is an International Nickel Co. trademark

™ Viton is a Dupont de Nemour trademark

™ DC200 is a Dow Corning Corporation trademark

™ Galden is a Montefluos trademark

™ Halocarbon is a Halocarbon Products Co. trademark

™ AN140 is a Wacker-Chemie trademark

™ Neobee M20 is a Stepan Company trademark

™ Marcol is a Esso Italiana trademark

™ Syltherm is a Dow Chemical Company trademark

## 2600T Pressure Transmitters

Model 268DS, 268PS, 268VS

---

ABB has Sales & Customer Support expertise in over 100 countries worldwide

[www.abb.com/instrumentation](http://www.abb.com/instrumentation)

The Company's policy is one of continuous product improvement and the right is reserved to modify the information contained herein without notice.

Printed in Italy (07.2008)

© ABB 2008



### ABB Ltd

Howard Road, St. Neots  
Cambridgeshire, PE19 8EU  
UK  
Tel: +44(0)1480 475321  
Fax: +44(0)1480 217948

### ABB Inc.

125 E. County Line Road  
Warminster, PA 18974  
USA  
Tel: +1 215 674 6000  
Fax: +1 215 674 7183

### ABB SACE

A division of ABB S.p.A.  
Via Statale 113  
22016 Lenno (CO) Italy  
Tel: +39 0344 58111  
Fax: +39 0344 56278