

ABB Softstarters

- The complete range

ABB Softstarters now cover the whole range from 3 A to 840 A

The PS D line has established an excellent, worldwide reputation for fine control, long life and reliability running large motors – up to 450 kW (400 V).

The new PS S line brings these benefits in a flexible and compact form for smaller motors.

Range of ABB Softstarters

PS S (Normal duty)	3 – 25 A
PS S (Normal duty)	18 – 300 A (inline)
	30 – 515 A (inside Delta)
PS DH (Heavy duty)	30 – 720 A
PS D (Normal duty)	75 – 840 A

Full load current (A)

Typical applications for softstarters:
Pumps (1)
Conveyor Belts (2)
Fans (3)
Lifts and Escalators (4)



ABB Building Technologies

ABB Softstarters

Ready for applications up to 515 A

ABB Softstarters

- the easy solution that will save you time and money

Using direct-on-line (DoL) and Star-Delta starting of squirrel cage motors results in very rough and jerky starts. High starting currents and torques are characteristics of direct-on-line starts while Star-Delta starts cause very high current and torque peaks when switching from star to delta connection.

- The high starting torques and torque peaks will over time wear and reduce life on all transmissions, such as gearboxes, belts, chains, couplings, bearings, etc. This leads to high maintenance costs, frequent stoppages and unnecessary down time. It can also create direct operational problems when starting and stopping pumps with water hammering in pipe systems and damaged goods when starting and stopping conveyor belts.

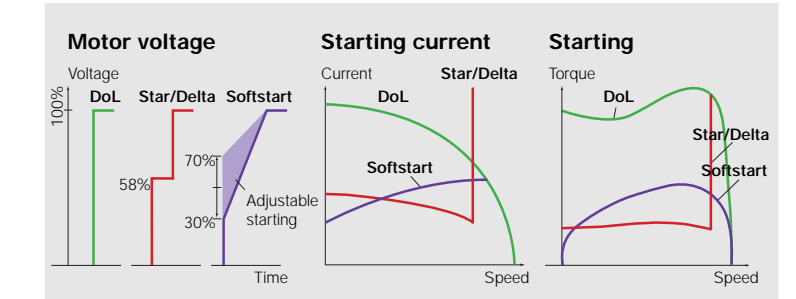

- High starting currents and current peaks result in voltage drops on the network that can cause severe overall operational problems.

The easy solution

The easy solution to all these problems is to install an ABB Softstarter type PS S, offering smooth and controlled starts and stops. This will save you both time and money.



CARE OF: Reference number TSFC 288006-en
ABB Control AB, SE-721 61 Västerås, Sweden. Phone +46 21 32 07 00, fax +46 21 12 60 01

ABB Softstarters

– the PS S line



	PS S 03...PS S 25		
Line connected, normal start, 400 V	1,1 kW	5,5 kW	11 kW
Inside Delta connected, normal start, 400 V	–	–	–
Type	PS S 03	PS S 12	PS S 25
Order code	PS S 03-220B	PS S 12-220B	PS S 25-220B
400 V	PS S 03-400B	PS S 12-400B	PS S 25-400B
480 V	PS S 03-480B	PS S 12-480B	PS S 25-480B
690 V	–	–	–
Rated current Ie/A	3	12	25

Fuse protection 400 V, 65 kA			
Bussmann Type	170M1359	170M1363	170M1364

Switch fuse			
Type	OS160R0380	OS160R0380	OS160R0380

Line contactor			
Type	B6	A12	A26

Thermal overload relay			
Type	T 6 DU	TA 25 DU	TA 25 DU

Current transformers			
Type	–	–	–

PS S 18/30...PS S 72/124			
7,5 kW	15 kW	18,5 kW	22 kW
15 kW	25 kW	30 kW	37 kW
Type	PS S 18/30	PS S 30/52	PS S 37/64
PS S 18/30-500	PS S 30/52-500	PS S 37/64-500	PS S 44/76-500
PS S 18/30-500	PS S 30/52-500	PS S 37/64-500	PS S 44/76-500
PS S 18/30-500	PS S 30/52-500	PS S 37/64-500	PS S 44/76-500
PS S 18/30-690	PS S 30/52-690	PS S 37/64-690	PS S 44/76-690
18	30	37	44

170M1364	170M1366	170M1368	170M1369
----------	----------	----------	----------

OS160R0380	OS160R0380	OS160R0380	OS160R0380
------------	------------	------------	------------

A16	A30	A40	A50
-----	-----	-----	-----

TA 25 DU	TA 25 DU	TA 42 DU	TA 42 DU
----------	----------	----------	----------

PS CT-60 2 turns	PS CT-40 1 turn	PS CT-50 1 turn	PS CT-60 1 turn
------------------	-----------------	-----------------	-----------------

25 kW	30 kW	37 kW
45 kW	55 kW	59 kW
PS S 50/85	PS S 60/105	PS S 72/124
PS S 50/85-500	PS S 60/105-500	PS S 72/124-500
PS S 50/85-500	PS S 60/105-500	PS S 72/124-500
PS S 50/85-500	PS S 60/105-500	PS S 72/124-500
PS S 50/85-690	PS S 60/105-690	PS S 72/124-690
50	60	72

170M1369	170M1370	170M1371
----------	----------	----------

OS160R0380	OS160R0380	OS160R0380
------------	------------	------------

A50	A63	A75
-----	-----	-----

TA 75 DU	TA 75 DU	TA 75 DU
----------	----------	----------

PS CT-75 1 turn	PS CT-75 1 turn	PS CT-100 1 turn
-----------------	-----------------	------------------

PS S 85/147...300/515					
45 kW	55 kW	75 kW	90 kW	132 kW	160 kW
75 kW	90 kW	132 kW	160 kW	220 kW	257 kW
PS S 85/147	PS S 105/181	PS S 142/245	PS S 175/300	PS S 250/430	PS S 300/515
PS S 85/147-500	PS S 105/181-500	PS S 142/245-500	PS S 175/300-500	PS S 250/430-500	PS S 300/515-500
PS S 85/147-500	PS S 105/181-500	PS S 142/245-500	PS S 175/300-500	PS S 250/430-500	PS S 300/515-500
PS S 85/147-500	PS S 105/181-500	PS S 142/245-500	PS S 175/300-500	PS S 250/430-500	PS S 300/515-500
PS S 85/147-690	PS S 105/181-690	PS S 142/245-690	PS S 175/300-690	PS S 250/430-690	PS S 300/515-690
85	105	142	175	250	300

Fuse protection 400 V, 65 kA					
170M1372	170M3019	170M3020	170M3021	170M4017	170M5015

Switch fuse					
OS 160R0380	OESA 250R03D80	OESA 250R03D80	OESA 250R03D80	OESA 250R03D80	OESA 250R03D80

Line contactor					
A95	A110	A145	A185	A260	A300

Thermal overload relay					
TA 110 DU	TA 110 DU	TA 200 DU	TA 200 DU	TA 450 DU	TA 450 DU

Current transformers					
PS CT-125 1 turn	PS CT-150 1 turn	PS CT-200 1 turn	PS CT-250 1 turn	PS CT-400 1 turn	PS CT-400 1 turn

ABB Softstarters type PS S 18/30 – PS S 300/515 are available in two versions: code F for supply voltage 110 – 120 V 50/60 Hz and code L for 220 – 240 V 50/60 Hz.
Example: 37 kW motor, connected in-line, 400 V network and supply voltage 230 V 50Hz – use order code: PS S 72/124-500L.

The PS S line

- Inside delta connection
- Safe and robust design
- Flexible and compact solution
- Total solid state solution
- Easy to use
- Solution for 690 V

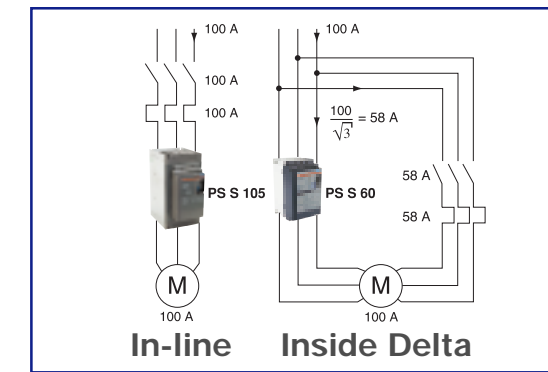

These units can be used both for 'In-line' or 'Inside delta' configuration. The latter gives a compact and flexible alternative to Y/D-starters. The 'Inside delta' configuration reduces costs as the current is only 58 % of the rated motor current.

The PS S line covers rated motor currents from 3 up to 515 A and main voltages between 208 V and 690 V. Common for the complete range is that they are compact and extremely easy to install and set up.

The flexible line for 18 up to 515 A: PS S 18/30...300/515

These softstarters provide a flexible solution. Rated motor currents in the range from 18 up to 300 A are covered. The unit can also be wired inside the motor-delta, like a star-delta starter, covering motors up to 515 A. This flexibility makes it easier than ever before to replace star delta starters.

The total solid state solution, e.g. no moving contacts in the main circuit, is an attractive solution for applications with many starts per hour. The clear marking on the front makes the installation and settings very easy. The adjustable parameters ramp time for start, ramp time for stop and initial voltage make it possible to adjust the softstarter for nearly all applications.



A typical 'Inside Delta' combination as a replacement for a Y/D-starter

All these units will reduce the current during start but the set up will be even easier if the optional current limit function is used. This function allows you to set a maximum starting current independently of starting time. This option can be added on during installation on site.

The units are provided with four LED's for *Supply On, Top of ramp, External fault and General fault*. This in addition to a built-in signal relay for faults make it easy to check the status and simplify service. Sometimes a motor is used above its own rated current, e.g. under well-cooled conditions. This is not a problem as PS S 18/30...250/430 are able to handle 15 % over current continuously (service factor 115 %).

The built-in signal contact, by-pass, can either be used for bypassing the unit or for sequential start of several motors.

The compact line for 3 up to 25 A: PS S 03...25

This is a very compact solution for starting up small motors with rated current from 3 to 25 A. It is suitable for 230, 400, 500 and 600 V and designed for DIN rail mounting.

The built-in by-pass contacts allow you to build space saving, compact systems.

The clear marking will make the installation and set up very easy. Possible setting of ramp time for start and stop including initial voltage make it possible to use the softstarter for a large number of different applications. The fact that the units cover a control voltage range of 24...110 Vac/dc and 110 V-480 Vac will only make things easier.

