



- Danger to life by electric voltage!
Power supplies must only be installed and taken into operation by adequately qualified personnel and under consideration of the local regulations (e.g. VDE, etc.).
- For further information and data, please refer to the product catalogs and data sheets or contact your local ABB office or visit our website under www.abb.com.
- No responsibility is taken for the correctness of technical information.
- Subject to technical changes without prior notice.
- The German original text is authoritative in case of doubt.

Without the express written permission of ABB Stotz-Kontakt GmbH, no part of this manual may be reproduced (by printing, photocopying, microfilming or any other technique) or copied, distributed or processed using electronic systems.

© ABB Stotz-Kontakt GmbH, Heidelberg, 09/2006

Contents

1. Introduction	3
2. Basic Principles of Power Supplies for Industrial Use	4
2.1 Electrical design	4
2.2. Power supply types and their design	5
2.2.1 Unregulated power supplies	6
2.2.2 Linearly regulated power supplies.....	7
2.2.3 Primary switch mode power supplies	8
2.2.4 Secondary switch mode power supplies	9
2.2.5 Summary	10
2.3. Safety	11
2.3.1 Electrical isolation.....	11
2.3.2 Insulation.....	11
2.3.3 Safe isolation.....	11
2.3.4 Secondary grounding	12
2.3.5 SELV	13
2.3.6 PELV	13
2.3.7 Class of protection	14
2.3.8 Degree of protection.....	14
2.3.9 Pollution degree	16
2.4. Approvals	17
2.5. Standards.....	19
2.6. Input voltage ranges.....	21
2.6.1 Wide-range input	21
2.6.2 Autorange	21
2.6.3 Manual range selection	21
2.7. Protective functions.....	22
2.7.1. Short-circuit and overload protection (output characteristics).....	22
2.7.2. Thermal protection	27
2.7.3. Open-circuit protection.....	28
2.7.4. Resistance to reverse feed	28
2.7.5. Overvoltage protection (secondary side).....	28
2.7.6. Power failure buffering.....	28
2.8. Fusing.....	29
2.8.1 Input fusing	29
2.8.2 Output fusing	29
2.8.3 Conductor cross section	29
2.8.4 Selectivity.....	30
2.9. PFC (Power Factor Correction).....	36
2.9.1 Harmonics	36
2.9.2 Passive PFC.....	37
2.9.3 Active PFC	37

Contents

3. ABB Product Range	38
3.1. Primary switch mode power supplies	38
3.1.1 Product overview CP-E, CP-S and CP-C	38
3.1.2 CP-E	40
3.1.3 CP-S.....	41
3.1.4 CP-C.....	42
3.1.5 CL-LAS.SD.....	43
3.2. Accessories	44
3.2.1 Redundancy unit CP-RUD for CP-E	44
3.2.2 Messaging module CP-C MM for CP-C.....	44
3.2.3 Redundancy unit CP-A RU for CP-S/C.....	45
3.2.4 Control module CP-A CM for CP-A RU	45
4. Applications	46
4.1. Engineering	46
4.2. Output voltage adjustment	49
4.2.1 Compensation of line losses.....	49
4.2.2 Balancing of power supplies.....	50
4.3. Parallel connection of power supplies	51
4.3.1 Parallel connection of power supplies for increased capacity.....	51
4.3.2 Parallel connection of power supplies for redundancy	53
4.3.3 Current balance.....	55
4.4. Series connection of power supplies	57
4.5. Monitoring functions	58
4.5.1 Monitoring of a single power supply using a CP-C with a CP-C MM.....	58
4.5.2 Monitoring of two power supplies using a CP-A RU with a CP-A CM	59
4.5.3 Monitoring of one power supply using a CP-A RU with a CP-A CM.....	60
4.6. Application example	61
4.6.1 Supply for an AF185 contactor.....	61
5. Appendix	62
5.1. Selectivity tables for section 2.8.4	62
5.2. List of figures	65
5.3. Index	66

1. Introduction

For today's applications, e.g. in control engineering, it is essential to take the right decision regarding the selection and planning of the power supply. Incorrect dimensioning or wrong connection of a power supply can seriously affect the safety and/or the availability of an entire installation.

This manual provides a general overview of switch mode power supplies and thus helps to choose the optimal power supply and to avoid problems during engineering and commissioning.

The manual generally shows and explains the fundamentals of and the differences between power supplies, and gives a detailed introduction to the ABB product range on the basis of the selection criteria.

Finally, it describes and explains application examples for engineering.

ABB STOTZ-KONTAKT GmbH
September 2006

Fabian Spranz

Markus Klein

2. Basic Principles of Power Supplies for Industrial Use

2.1 Electrical design

A simplified consideration of the electrical design of power supplies allows to consider them as a device with an input side and an output side. The input side and the output side are electrically isolated against each other.

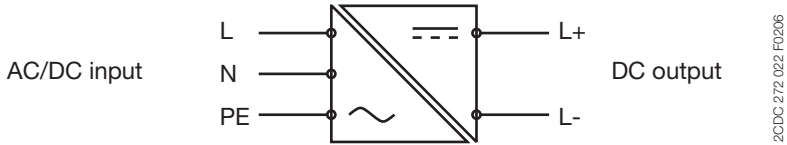

Figure 1 – Simplified consideration of the electrical design

The following table lists the most important terms regarding the input side and the output side.

Input side	Output side
Primary side	Secondary side
Input voltage	Output voltage
Primary grounding	Secondary grounding
Current consumption	Short-circuit current
Inrush current	Residual ripple
Input fuse	Output characteristics
Frequency	Output current
DC supply	
Power failure buffering	
Power factor correction (PFC)	

Table 1 – Terms regarding input and output side

2. Basic Principles of Power Supplies for Industrial Use

2.2. Power supply types and their design

Two major types of power supplies are distinguished: regulated power supplies and unregulated power supplies. Regulated power supplies are further divided into linearly regulated power supplies and switch mode power supplies.

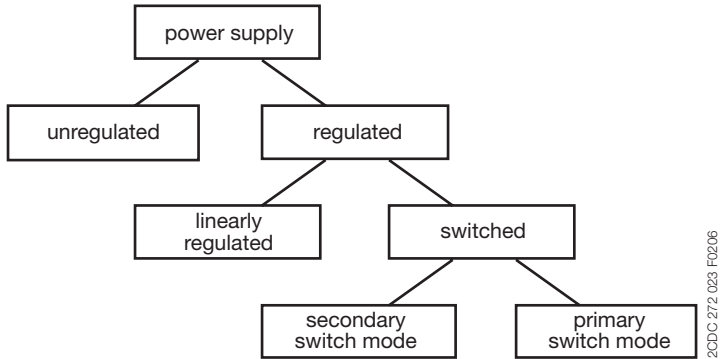

Figure 2 – Overview of power supply types

The various power supply types are explained below in more detail. However, the explanations only deal with the basic technology and not with circuit engineering details.

2. Basic Principles of Power Supplies for Industrial Use

2.2.1 Unregulated power supplies

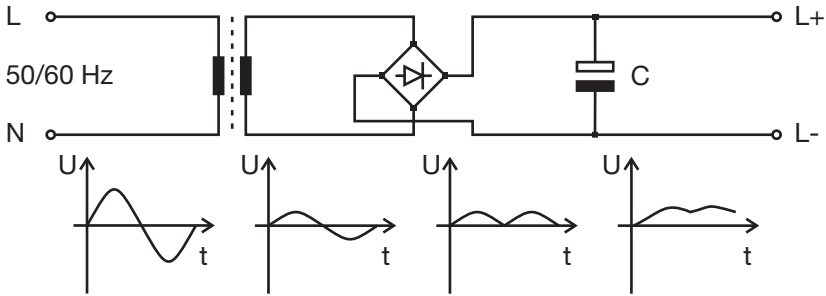

Figure 3 – Unregulated power supply

2CDC 272-024 F0606

The AC mains voltage (50/60 Hz) applied at the input side is transformed to a lower level and rectified by a subsequent rectifier. Then, a capacitor C smooths the output voltage of the rectifier. The dimension of the transformer depends on the desired output voltage.

Due to the design of the electric circuit, the output voltage directly depends on the input voltage which in turn means that variations of the mains voltage have direct effect to the output side. Since no regulation is done on the secondary side, the residual ripple of the output voltage is in the dimension of volts and specified as a percentage of the DC output voltage.

Due to their simple design, unregulated power supplies are very robust and durable. Their efficiency is approx. 80 %.

Unregulated power supplies are primarily used for simple electromechanical applications that do not require exact output voltages, e.g. for the supply of contactors.

Advantages	Disadvantages
High efficiency Durable Cost-efficient	Large size High residual ripple No DC supply

2. Basic Principles of Power Supplies for Industrial Use

2.2.2 Linearly regulated power supplies

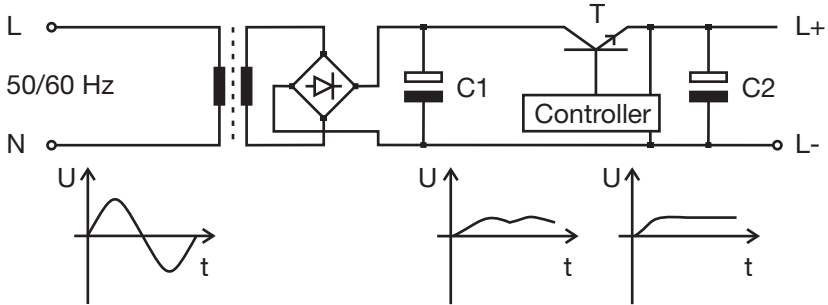

Figure 4 – Linearly regulated power supply

2CDC 272 02S F0006

The AC mains voltage is transformed to a lower level, rectified and smoothed by capacitor C1. Then, voltage regulation is performed, typically using a power transistor. The power transistor acts as a variable resistor, controlled to keep the output voltage constant.

The efficiency of linearly regulated power supplies is only approx. 50 % due to the high losses inside the power transistor. The remaining energy is emitted in the form of heat. Due to this, sufficient ventilation is required to cool the power supply. Compared with unregulated power supplies, linearly regulated power supplies have a very small residual ripple of the output voltage (in the dimension of millivolts).

Linearly regulated power supplies are used for all applications that require a very exact output voltage, e.g. for highly precise medical devices.

Advantages	Disadvantages
Short regulation times	Poor efficiency
Small residual ripple	Large size
Simple circuitry	No DC supply

2. Basic Principles of Power Supplies for Industrial Use

2.2.3 Primary switch mode power supplies

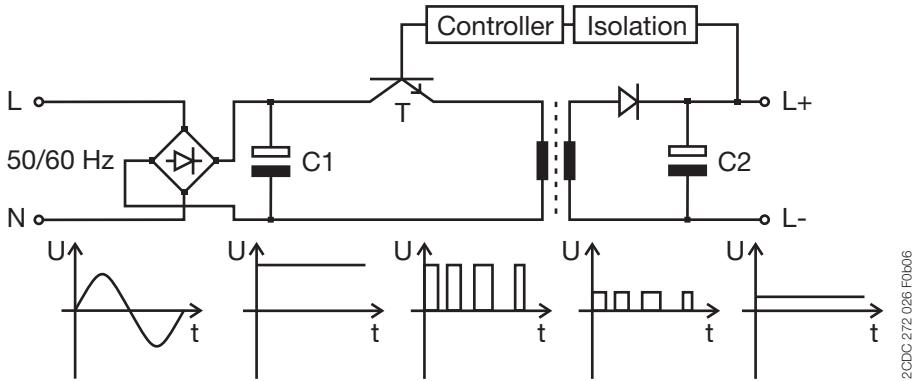

Figure 5 – Primary switch mode power supply

2006 272 026 F0006

In primary switch mode power supplies, the AC mains voltage is first rectified and smoothed and then chopped ("switched"). Chopping means that the DC voltage is switched periodically at a frequency of 40 to 200 kHz using a power transistor.

In contrast to linearly regulated power supplies, the power transistor does not act as a variable resistor but as a switch instead. This generates a square-wave AC voltage that is transformed to the secondary circuit using a high-frequency transformer. In the secondary circuit, the voltage is rectified and smoothed. The quantity of energy transformed to the secondary circuit is controlled, depending on the load, by varying the chopping rate. The longer the transistor is conductive, the higher is the quantity of energy transformed to the secondary circuit (pulse width modulation).

Due to the use of high-frequency AC voltage, primary switch mode power supplies have the decisive advantage that their transformer can be of much smaller size than required for the transformation of low frequencies. This reduces the weight and the dissipation inside the unit. The efficiency of these units is between 85 and 95 %. Since the output voltage does not directly depend on the input voltage, these units can be used for a wide input voltage range and can even be supplied with DC voltage. Furthermore, it is possible to buffer short-time mains voltage breakdowns up to 200 ms. However, the power failure buffering time is limited by the size of capacitor C1 since a longer buffering time requires a higher capacity and thus a bigger size of the capacitor. Especially in case of small power supplies this is not desirable. Therefore, a practicable compromise has to be made between the size of the power supply and the buffering time.

Primary switch mode power supplies can be used for all purposes. For example, they are suitable for the supply of all kind of electronics as well as for electromechanical applications.

2. Basic Principles of Power Supplies for Industrial Use

Advantages	Disadvantages
Small size Light weight Wide input voltage range Easy to regulate High efficiency DC supply Buffering in case of mains voltage breakdown	Complex circuitry Mains pollution High frequency requires interference suppression measures Expensive

2.2.4 Secondary switch mode power supplies

The design of secondary switch mode power supplies differs in only one detail from the design of primary switch mode power supplies. Chopping is performed on the secondary side. As a result, a much bigger transformer has to be used since it has to transform the mains voltage of 50/60 Hz. However, the transformer also acts as a filter and thus minimizes the mains pollution.

Advantages	Disadvantages
High efficiency Easy to regulate Wide input voltage range Low mains pollution	Large size No DC supply Expensive

2. Basic Principles of Power Supplies for Industrial Use

2.2.5 Summary

During the last years, primary switch mode power supplies became particularly accepted in the field of industrial applications. Their ability to accept almost any input voltage, their high efficiency and their compact design make these power supplies a first class choice for the engineering of new or the extension of existing installations.

The following table compares the different types of power supplies, taking into account their most important characteristics.

	Unregulated	Linearly regulated	Primary switch mode
Efficiency	+	--	++
Regulation time	--	++	+
Weight and size	--	-	++
Residual ripple	--	++	+
Costs	++	-	--
Fields of application	--	+	++

Table 2 - Comparison of different power supply types

2. Basic Principles of Power Supplies for Industrial Use

2.3. Safety

The safety of persons and installation equipment is a major aspect even for power supplies. The requirements to be fulfilled in order to guarantee this safety are specified by standardized regulations. The most important terms from this field are listed and explained below.

2.3.1 Electrical isolation

Electrical isolation means that no current flow can occur from one electric circuit to a neighboring other electric circuit.

In case of power supplies, this means that no electric connection exists between the input side and the output side.

2.3.2 Insulation

Different insulation types are defined in the standard IEC/EN 60950.

- **Functional insulation**
Insulation necessary for the proper operation of the equipment.
- **Basic insulation**
Insulation providing basic protection against electric shock.
- **Supplementary insulation**
Protection against electric shock in the event of failure of the basic insulation.
- **Double insulation**
Insulation comprising both basic insulation and supplementary insulation.
- **Reinforced insulation**
A single insulation system which provides a degree of protection against electric shock equivalent to double insulation.

2.3.3 Safe isolation

Safe isolation according to EN 50178 is required for all interfaces between different electric circuits, e.g. between an SELV circuit and a mains circuit.

Safe isolation means that no current flow can occur from one electric circuit to another. This isolation has to be implemented either by double or reinforced insulation or by means of protective shielding.

2. Basic Principles of Power Supplies for Industrial Use

2.3.4 Secondary grounding

In case of secondary grounding, the output side of the power supply is connected to protective earth (PE) in order to prevent dangerous ground faults.

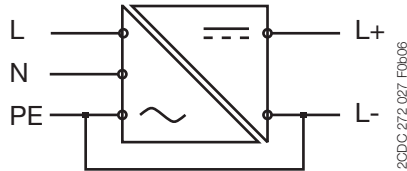

Figure 6 – Secondary grounding

A ground fault occurs if a current-carrying line has contact to earth. In the worst case, two simultaneous ground faults can lead to a bridging of switches and thus can start equipment accidentally.

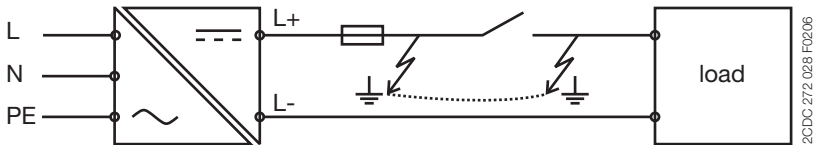

Figure 7 – Ground fault

If secondary grounding is used, the occurrence of such a ground fault leads to a so-called short circuit to earth which causes the fuses in the secondary circuit to trip.

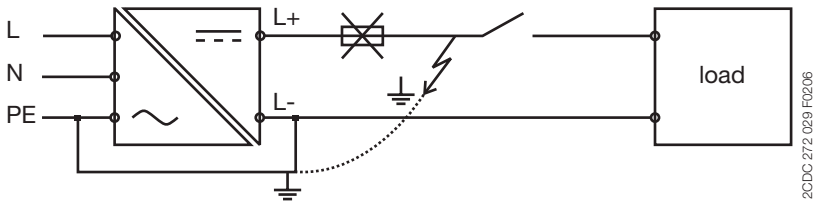

Figure 8 – Short circuit to earth

2. Basic Principles of Power Supplies for Industrial Use

2.3.5 SELV

SELV according to IEC/EN 60950 is a safety extra low voltage. This voltage is so small that no danger due to current flowing through the human body can occur in case of direct contact, neither during rated operation nor in case of a single fault. In case of power supplies, this is achieved through electrical isolation and double or reinforced insulation between the primary side and the secondary side. Grounding of the secondary side is not required but permitted.

The peak value must not exceed 42.4 V in case of AC voltages and 60 V in case of DC voltages. Lower voltages are defined for particular applications (e.g. toys).

2.3.6 PELV

PELV according to IEC/EN 60950 is a protective extra low voltage. In case of PELV, the electric circuits are grounded and (like SELV) safely isolated from circuits of higher voltages. The voltage limits are identical to SELV.

2. Basic Principles of Power Supplies for Industrial Use

2.3.7 Class of protection

The standard IEC/EN 61140 defines protection classes for electrical equipment. The devices are classified according to the safety measures taken to prevent electric shock.

The protection classes are divided into the classes 0, I, II and III.

- **Protection class 0**

Apart from the basic insulation there is no protection against electric shock. These devices cannot be connected to electrical installations with PE. Equipment of class 0 is not allowed in Germany. Protection class 0 will no longer be considered in future versions of the standard.

- **Protection class I**

In addition to the basic insulation, all electrically conductive parts of the housing are connected to PE. This guarantees that no electric shock can occur in the event of an insulation failure.



- **Protection class II**

Protection against electric shock is not only based on the basic insulation. The housing is equipped with reinforced or double insulation.



If the housing is made of electrically conductive material, no direct contact between the housing and current-carrying parts is possible. The housings of class II devices are not equipped with a PE connection.

It is important to note that the PE connection is not only used for the grounding of housings but also to connect filters for EMC measures (electromagnetic compatibility) to ground. This is why even devices the housings of which are completely made of plastic material can be equipped with a PE connection.

- **Protection class III**

The device is operated with safety extra-low voltage and thus does not require any protection measures.



Power supplies are usually class I or II equipment.

2.3.8 Degree of protection

According to DIN EN 60529, electrical equipment is classified using so-called IP codes. IP stands for "International Protection" or "Ingress Protection". The IP code consists of two figures: The first digit specifies the protection against accidental contact and against ingress of solid foreign bodies, the second digit specifies the protection against ingress of water.

2. Basic Principles of Power Supplies for Industrial Use

Digit 1: Protection against accidental contact and ingress of solid foreign bodies

Digit	Protection against accidental contact	Protection against ingress of solid foreign bodies
0	No protection	No protection
1	Safe against touch of large body parts (diameter: 50 mm)	Large solid foreign bodies (diameter: > 50 mm)
2	Safe against finger touch (diameter: 12 mm)	Medium-sized solid foreign bodies (diameter: > 12.5 mm; length: < 80 mm)
3	Tools and wires (diameter: > 2.5 mm)	Small solid foreign bodies (diameter: > 2.5 mm)
4	Tools and wires (diameter: > 1 mm)	Granular solid foreign bodies (diameter: > 1 mm)
5(K)	Completely safe against contact	Deposit of dust
6(K)	Completely safe against contact	Ingress of dust

Table 3 – Degrees of protection against accidental contact and ingress of solid foreign bodies

Digit 2: Degrees of protection against ingress of water

Digit	Protection against ingress of water
0	No protection
1	Protection against dripping water falling vertically
2	Protection against water drops falling up to 15° from the vertical
3	Protection against spray-water, sprayed at an angle of up to 60° either side of the vertical
4	Protection against splash-water (against the housing from every direction)
4k	Protection against splash-water at increased pressure (against the housing from every direction), only applicable for road vehicles
5	Protection against jet-water
6	Protection against strong jet-water (conditions on ships deck)
6k	Protection against strong jet-water at increased pressure (conditions on ships deck), only applicable for road vehicles
7	Protection against the effects of temporary submersion in water
8	Protection against the effects of permanent submersion in water
9k	Protection against water during high pressure/ steam cleaning, only applicable for road vehicles

Table 4 – Degrees of protection against ingress of water

Power supplies usually are classified with **IP20**. This is sufficient for use in control cabinets.

2. Basic Principles of Power Supplies for Industrial Use

2.3.9 Pollution degree

The pollution degree according to DIN EN 50178 defines the type of pollution to be expected at the device's place of installation. To be allowed for use in a specific environment, devices must be resistant against this particular type of pollution.

The pollution degree is divided into four classes.









Pollution degree	Conditions in the immediate environment
1	Occurrence of dry, non-conductive pollution only. The pollution has no effect to the device.
2	Only non-conductive pollution occurs under normal conditions. Occasional short-term conductivity due to condensation has to be expected when the device is out of operation.
3	Occurrence of conductive pollution or occurrence of dry, non-conductive pollution that becomes conductive due to expected condensation.
4	Pollution leads to permanent conductivity, e.g. caused by conductive dust, rain or snow.

Table 5 – Pollution degrees

Power supplies that are intended for industrial use are usually classified for pollution degree 2.

2. Basic Principles of Power Supplies for Industrial Use

2.4. Approvals and marks

- **UL 508** 
Underwriters Laboratories (UL) Listing
The product is approved for installation in systems and for sale as individual component in the USA.
- **UR** 
Recognition
The component is approved for installation in systems, if the respective system was completely mounted and wired by qualified personnel.
- **CSA** 
Canadian Standards Association
The Canadian counterpart of UL. The contents of Canadian standards are equivalent to US standards.
- **cULus** 
cURus 
The combined UL marks for USA and Canada are accepted by the authorities of both countries. Devices with this certificate meet the requirements of both countries.
- **CB scheme** 
CB scheme is based on the principle of mutual acceptance of test results by over 30 participating certification bodies. It was introduced to facilitate international trading. CB scheme was founded by the "International Electrotechnical Committee for Conformity Testing to Standards for Electrical Equipment" (IECEE). Product testing is performed by an independent institute according to an IEC standard.
- **GOST** 
Mark for low-voltage switchgear components in Russia.
Gost R certification is mandatory for many products. It is based on safety tests (acc. to IEC standards with specific differences for Russia) and an EMC test.
- **CCC** 
China Compulsory Certification
In China, the CCC mark is a mandatory mark for products intended for sale on the Chinese market. The CCC mark deals with product safety and is based on IEC standards.

2. Basic Principles of Power Supplies for Industrial Use

- **UL 1604 (Class I, Div. 2)**
CSA 22.2/213

A "Class I, Div. 2" environment is an environment where dangerous gases and fluids are used or produced ("hazardous area"). However, the gases and fluids are stored in safe containers from where they can only escape in the event of an accident or a defect.

Devices that are approved according to UL 1604 (Class I, Div. 2) are not able to ignite these substances or mixtures of these substances with air in case of an accident.

- **UL 1310 (class 2 power supply)**

A "class 2 power supply" is a power supply the input power consumption of which does not exceed 660 W, independent of its output load. The output voltage must not exceed 42.4 V AC or 60 V DC.

- **CE** 

Conformité Européen (CE)

All products that comply with the European low voltage directive and the EMC directive and that are intended for sale within the European Union must have the CE mark applied.

The CE mark must not be confused with a certificate of quality issued by the EU. It is solely used to confirm that the respective product complies with the applicable European directives. The CE mark is part of an administrative procedure to guarantee free movement of goods within the European Community.

Manufacturers apply the CE mark on their own responsibility to the products and confirm the observance of the applicable guidelines by a certificate of conformity.

- **C-Tick** 

This mark confirms the observance of the Australian standards for electromagnetic compatibility. It is also accepted in New Zealand.

2. Basic Principles of Power Supplies for Industrial Use

2.5. Standards

Standards define and regulate standardized terms, methods and systems.

The standardization of definitions has the following goals:

- Avoid misunderstanding in communication
- Guarantee the quality
- Cost reductions
- Enable the transfer of technology
- Support of cross-company and international cooperation
- Equal safety standards

The most important standards committee is the "International Electrotechnical Commission (IEC)" based in Geneva. This committee consists of representatives of the member countries representing the individual national electrotechnical interests.

Its European counterpart is the "European Committee for Electrotechnical Standardization" (Comité Européen de Normalisation Electrotechnique, CENELEC).

The following table provides a brief overview of standards applicable for power supplies.

Product standard	IEC/EN 61204	Low-voltage power supply units with DC output
Low Voltage Directive	73/23/EEC	Directive from 19 February 1973 of the council of the European community for meeting the requirements of the member states regarding electrical equipment for use within particular voltage limits
Electrical safety	EN 50178	Electronic equipment for use in power installations
	UL 508	US safety standard for industrial control systems, content similar to EN 50178
	IEC/EN 60950	Information technology equipment – Safety – Part 1: General requirements
	UL 60950 CSA 22.2	US version or Canadian version of the standard IEC/EN 60950
EMC directive	89/336/EEC	Directive from 3 May 1989 of the council of the European community for meeting the requirements of the member states regarding the electromagnetic compatibility

2. Basic Principles of Power Supplies for Industrial Use

EMC (immunity) (in parts)	IEC/EN 61000-6-1	Generic standards, noise immunity - Immunity for residential, commercial and light-industrial environments
	IEC/EN 61000-6-2	Generic standards, noise immunity - Immunity for industrial environments
	IEC/EN 61000-4-2	Testing of immunity to electrostatic discharge
	IEC/EN 61000-4-3	Testing of immunity to high-frequency electromagnetic fields
	IEC/EN 61000-4-4	Testing of immunity to fast electrical transients (bursts)
	IEC/EN 61000-4-5	Testing of immunity to impulse voltages (surges)
	IEC/EN 61000-4-6	Immunity to conduction-bound interferences, induced by high-frequency fields
EMC (emission) (in parts)	IEC/EN 61000-6-3	Generic standards - Emission standard for residential, commercial and light-industrial environments
	IEC/EN 61000-6-4	Generic standards - Emission standard for industrial environments
	EN 55022 IEC/CISPR 22	Information technology equipment, radio disturbance characteristics - Limits and methods of measurement
PFC (Power Factor Correction)	IEC/EN 61000-3-2	Limits for harmonic current emissions (equipment input current ≤ 16 A per phase)

Table 6 – Overview of standards

2. Basic Principles of Power Supplies for Industrial Use

2.6. Input voltage ranges

2.6.1 Wide-range input

Wide-range input means that the device can be operated with any voltage within the specified limits. Therefore, many modern power supplies can be operated with AC voltages between 85 and 264 V and DC voltages between 100 and 350 V without any loss of power, i.e. the device is able to deliver the specified rated power over the entire input voltage range. Due to this technology, the devices are immune against mains voltage variations within these limits.

Power supplies with wide-range input can be connected to almost any power supply system all over the world and thus can reduce costs for stock keeping and logistics since one variant is able to cover almost all needs.

2.6.2 Autorange

Power supplies that are equipped with autorange behavior perform an internal measurement of the applied supply voltage and automatically switch between the available input voltage ranges.

However, if the input voltage level is outside of the defined ranges, the autorange behavior turns to a drawback since no reliable operation is possible in this case.

Power supplies with autorange input are often also described as wide-range devices by mistake.

2.6.3 Manual range selection

In case of manual range selection, the housing of the device is equipped with a selector switch for manual input voltage range selection.

Usual switch settings are "110 V" and "230 V". When set to "110 V", the devices often can be operated with AC voltages between 85 and 132 V. When set to "230 V", the devices usually can be operated with AC voltages between 184 and 264 V and with DC voltages between 220 and 350 V (refer to data sheet!).

2. Basic Principles of Power Supplies for Industrial Use

2.7. Protective functions

Modern power supplies are equipped with various protective functions to protect the device itself as well as the connected loads against damage.

2.7.1. Short-circuit and overload protection (output characteristics)

Various output characteristics are available for power supplies to provide electronic protection of the devices against damages due to overload or short circuit. The term overload means that the current consumed by the loads exceeds the rated output current of the power supply. A short circuit is a special form of an overload. In the event of a short circuit, the output conductors of the power supply are connected to each other very low-resistively and thus cause the output current to reach its maximum value, the so-called short circuit current.

The output characteristic of a power supply is important for engineering. It plays a major role, if it is required to start motors or other loads with high inrush currents, to perform a selective switch-off of secondary branches, to bring an installation into a safe condition in case of an overload or to switch off the power supply in case of a fault for reasons of process safety.

Fold-back characteristic / Hiccup mode

Power supplies usually are able to deliver a current of 1.1 times the rated current. They automatically switch off, if the current consumption of the connected load exceeds this value or if a short circuit occurs. After a defined period of time, the power supplies try to restart the load and automatically switch off again, if the overload or the short circuit still exists. This procedure repeats until the fault is cleared, i.e. the power supply will go into hiccup mode.

This mode is exclusively used for power supplies with low output power since there are several drawbacks. For example, if the power supply has to start high loads (e.g. a motor), the high inrush current will cause the power supply to go into hiccup mode. A further drawback is that the power supply switches off very fast in case of a short circuit which makes secondary fusing very difficult.

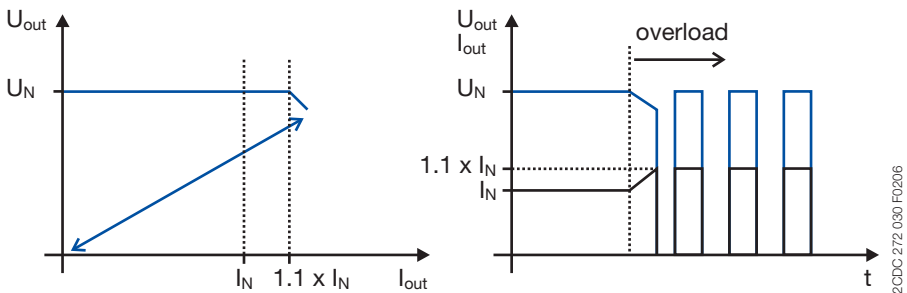

Figure 9 – Hiccup mode

2. Basic Principles of Power Supplies for Industrial Use

U/I characteristic

Power supplies with a U/I characteristic perform current limiting to typically 1.1 to 1.2 times the rated current at constant output voltage. This current is still available in case of an overload or a short circuit. In this case, the power supply either immediately cuts the output voltage to zero (rectangular current limiting) or performs slow lowering of the output voltage, what, however, can possibly lead to a further increase of the output current (triangular current limiting).

Since the current does not sag in case of an overload, this method enables reliable starting of high loads.

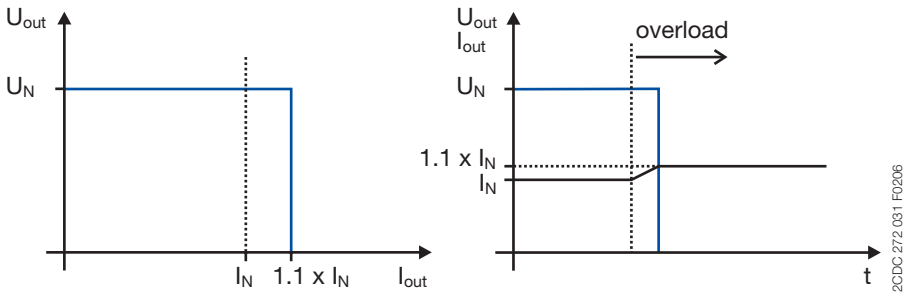

Figure 10 – Rectangular current limiting

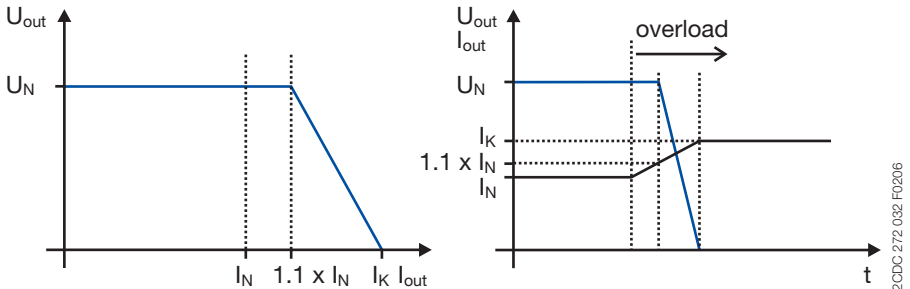

Figure 11 – Triangular current limiting

2. Basic Principles of Power Supplies for Industrial Use

U/I characteristic with power reserves (fold-forward)

Power supplies with a U/I characteristic and power reserves are able to deliver output currents of up to 1.5 times the specified rated current at the rated output voltage. In addition to this reserve, the power supply is able to manage a further output current increase of up to 50 %, however at decreasing output voltage (refer to "U/I characteristic"). The amount of current reserves the power supply can deliver and how long it is able to deliver the reserves primarily depends on the ambient temperature.

This method guarantees reliable starting even of very high loads. The high output current delivered in case of a short circuit makes secondary fusing easy. Therefore, this kind of power supplies is particularly suitable for industrial use.

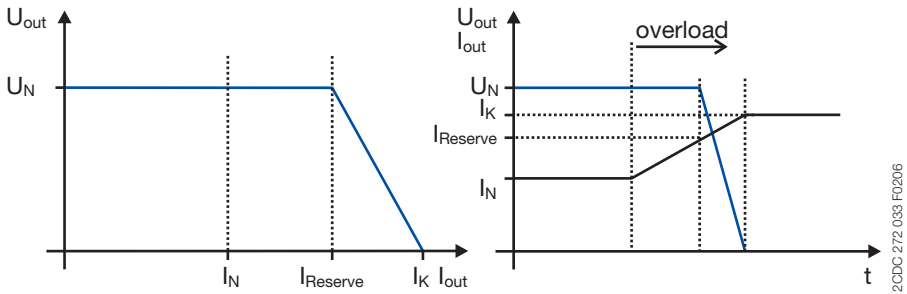

Figure 12 – U/I characteristic with power reserves

2CDC 27/2 033 F0206

2. Basic Principles of Power Supplies for Industrial Use

Effects of the ambient temperature to the output characteristic

The ambient temperature has direct effects to the maximum possible output power of a power supply and thus also to its behavior in case of an overload or a short circuit.

The temperature inside of control cabinets can rise to more than 60 °C due to the waste heat of the internal devices, solar irradiation or its place of installation. Power supplies must be able to work reliably even under these high temperatures.

However, starting from a certain temperature value, the maximum available output power will decrease depending on the temperature. The limit value starting from which this derating process takes place, ranges from 40 °C to 60 °C, depending on the technical design and the manufacturer of the power supply. The difference in temperature at which the derating process starts is caused by the quality of the internal components.

The difference between the ambient temperature and the internal temperature of the power supply is approximately 25 °C. As a result, no reserves will be available and the internal components will be operated at their temperature maximum, if a manufacturer specifies a maximum ambient temperature of 60 °C for a power supply the internal components of which are specified with a rated operating temperature of maximum 85 °C. ABB almost exclusively uses components with a rated operating temperature of up to 105 °C and guarantees proper operation of their power supplies up to an ambient temperature of 70 °C resulting in a maximum internal temperature of approx. 95 °C. This increases the lifetime of our power supplies since the components are not operated at their limits.

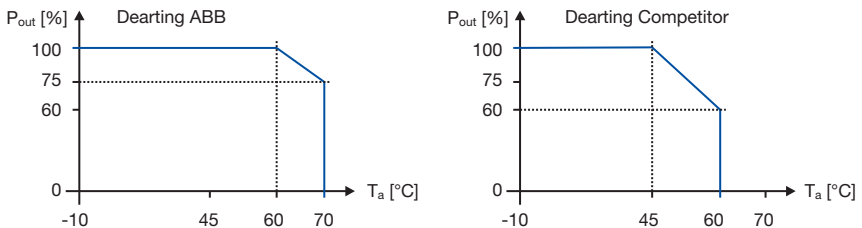

Figure 13 – Derating diagrams

Depending on the device it is also possible that power supplies are not able to deliver their full output power at very low ambient temperatures. This behavior is caused by an NTC thermistor attached to the input circuits to limit the inrush current. In case of very low temperatures, the resistance of this thermistor rises so high that the power supply is not able to deliver its full output power.

2. Basic Principles of Power Supplies for Industrial Use

Example:

Figure 14 shows the effects of the ambient temperature to the possibly available power reserves. At ambient temperatures below 40 °C, the power supply is able to deliver a continuous current of 7.25 A with constant rated output voltage instead of its specified rated current of 5 A. Starting at a load of 7.25 A, the output voltage decreases continuously until the maximum output current of 11 A is reached. When the ambient temperature is between 40 °C and 60 °C, the decrease of the output voltage already starts at a current of 5 A and again ends at 11 A.

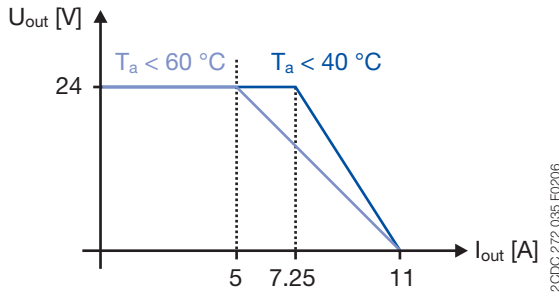

Figure 14 – Derating example

Summary

Today, most power supplies for industrial use with output currents of approx. 5 A and higher are equipped with a U/I output characteristic behavior. The advantage is clear: A constantly high output current in case of overload or short circuit.

However, for increased requirements the U/I characteristic with power reserve gains more and more acceptance due to its clear advantages.

The following table lists all available output characteristics with an assessment of their suitability for different tasks.

	Hiccup	U/I	U/I + reserve
Starting of motors	-	+	++
Tripping of fuses	--	+	++
Tripping of circuit breakers	--	o	+

Table 7 – Comparison of output characteristics

2. Basic Principles of Power Supplies for Industrial Use

2.7.2. Thermal protection

When operating a power supply under extreme conditions for a long duration, e.g. in case of permanent operation within the power limits or in case of very high ambient temperatures, the power supply can heat up to a degree where safe operation is no longer guaranteed. There are several methods to protect the power supply against damaging due to overtemperature.

- Reduction of the maximum output power to allow the power supply to cool down.
- The device is switched off completely and cannot resume operation until a manual reset is performed. Depending on the manufacturer, the reset is done either using a corresponding switch or by disconnecting the supply voltage.
- The device only switches off the output and does not switch it on until the temperature falls below a certain limit value (refer to Figure 15).
This is the most frequently used method for modern power supplies.

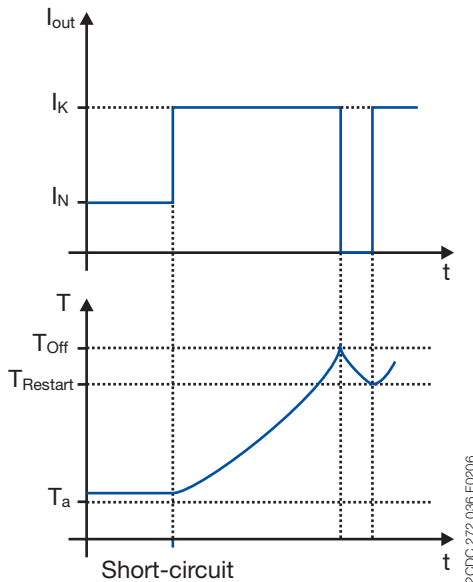

Figure 15 – Thermal switch-off

2. Basic Principles of Power Supplies for Industrial Use

2.7.3. Open-circuit protection

Open-circuit protected power supplies do not require any minimum load to deliver a stable output voltage. This is important e.g. for time-critical applications where a connected load has to be supplied with voltage immediately. In case of power supplies that are not open-circuit protected, it can last up to seconds until a connected load is actually supplied with voltage.

2.7.4. Resistance to reverse feed

The resistance to reverse feed specifies up to which voltage a power supply is immune against the feeding of voltages into the secondary side.

Such a current flow can occur, if further voltage supplies are connected in parallel to the power supply.

2.7.5. Overvoltage protection (secondary side)

In case of an internal error of the power supply, this protection mechanism prevents the occurrence of overvoltage on the secondary side that could possibly damage or even destroy a connected load or exceed the SELV voltage limit.

2.7.6. Power failure buffering

Modern power supplies are able to maintain their output voltage for a certain time in case of supply voltage dips. Usually, a power failure buffering time of at least 20 ms is aspired in order to provide buffering for one complete cycle of the mains voltage.

2. Basic Principles of Power Supplies for Industrial Use

2.8. Fusing

2.8.1 Input fusing

If the power supply is equipped with an internal fuse, it is not necessary to protect the device by an additional external fuse. If this internal fuse blows, the device can be considered as defective.

However, the standards define that it has to be possible to externally isolate power supplies from the supplying mains. The use of circuit breakers on the primary side is particularly suitable for this purpose.

2.8.2 Output fusing

Almost all power supplies intended for industrial use are protected against overload and short circuit by their internal electronics (refer to "Short-circuit and overload protection (output characteristics)"). Therefore, if not explicitly stated, no additional fusing on the secondary side is required for the purpose of device protection (refer to "Selectivity").

2.8.3 Conductor cross section

If the power supply is equipped with a U/I output characteristic with power reserves, the output current will exceed the rated current in case of an overload or a short circuit. This has to be considered when dimensioning the conducting wires on the secondary side. For instance, the continuous short-circuit current of a power supply rated with 20 A can be up to 25 A depending on the manufacturer.

The following table provides an overview of the current-carrying capacities of flexible multi-stranded copper conductors depending on the conductor cross section for a temperature of 30 °C and rated voltages up to 1000 V (acc. to DIN 57100-523).

Conductor cross section in mm²	0.75	1.0	1.5	2.5	4	6
Current-carrying capacity in A	12	15	18	26	34	44

Table 8 – Current-carrying capacities of copper conductors

2. Basic Principles of Power Supplies for Industrial Use

2.8.4 Selectivity

Selectivity means the tripping coordination. In electrical systems, distinction can be made between the "series selectivity" which means that individual fuses connected in series are selective against each other and the "parallel selectivity" which means that electric circuits connected in parallel are selective against each other.

Series selectivity

In case of series-connected fuses, the tripping coordination of fuses is considered as selective, if only the fuse installed nearest to the fault trips. Fuses that are located nearer to the energy feeding point do not trip. This guarantees that as many system parts as possible remain operative in the event of one single fault resulting in an increased availability of electrical systems.

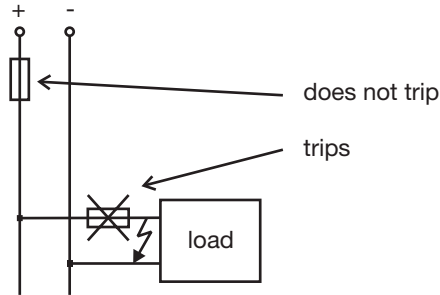

20DC 272 037 F0206

Figure 16 – Series selectivity

2. Basic Principles of Power Supplies for Industrial Use

Parallel selectivity

If one power supply is used to supply several loads, the occurrence of a short circuit at one consumer will cause the power supply to enter its current limiting mode. This results in a supply voltage dip at all connected load branches. To prevent this, the supply lines of the individual load branches are equipped with fuses or circuit breakers. In order to guarantee reliable isolation of the faulty load and to keep the remaining system operative in case of a short circuit, the tripping time of the corresponding fuse or circuit breaker has to be sufficiently short.

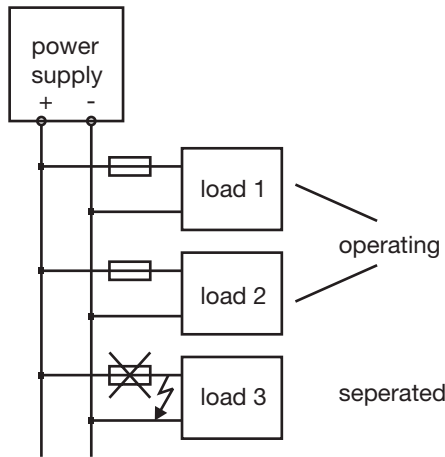

Figure 17 – Parallel selectivity

2. Basic Principles of Power Supplies for Industrial Use

Tripping of fuses / circuit breakers

Tripping of fuses is always based on a thermal mechanism. In case of an overload, the conductor inside the fuse heats and finally blows as a result. Depending on the type of fuse and the amount of overload, the tripping time can range from milliseconds up to hours.

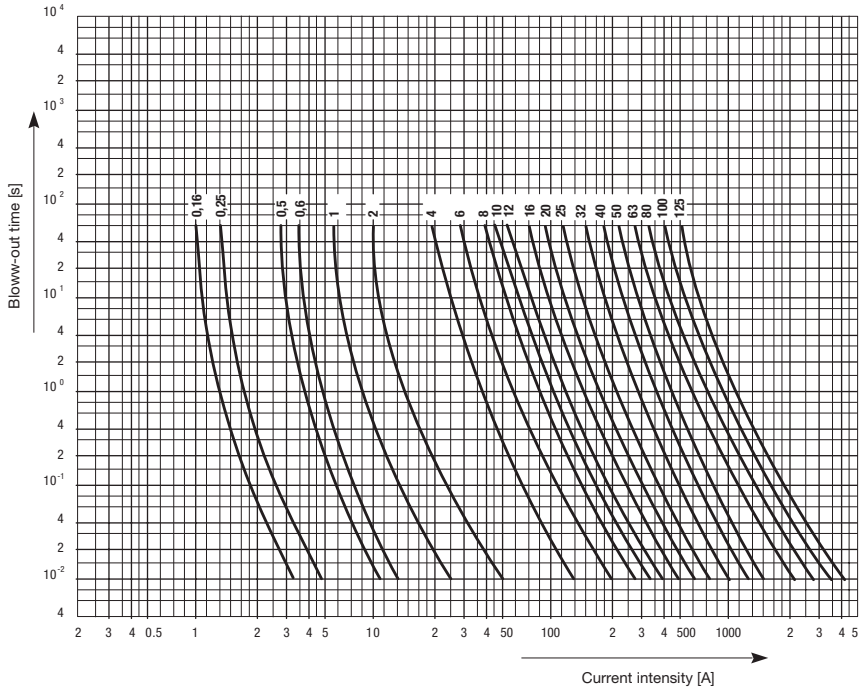

Figure 18 – Tripping characteristic curve of a fuse (tripping time vs. current)

Circuit breakers are equipped with two tripping mechanisms, a thermal and a magnetic mechanism.

Magnetic tripping is performed within milliseconds and typically caused by a short circuit. The current required for magnetic tripping is a multiple of the rated current. Magnetic tripping can also be caused by high overloads.

The thermal tripping mechanism of circuit breakers is similar to fuses but based on a bimetal mechanism. The bimetal deforms depending on the current intensity and the duration of current flow and thus trips the breaker latching mechanism which in turn disconnects the electric circuit. The tripping times depend on the respective tripping characteristic and can range from seconds to minutes.

2. Basic Principles of Power Supplies for Industrial Use

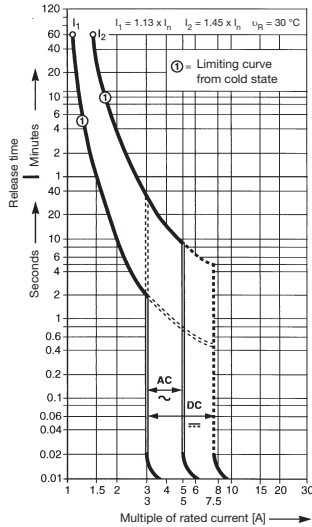

Figure 19 – Tripping characteristic curve of a circuit breaker (tripping time vs. current, tripping characteristic "B")

Setting up a protection system with series selectivity using fuses and circuit breakers

Fuses are considered as selective if their rated currents differ clearly. The determination whether particular fuses are selective against each other or not, can be done on the basis of the tripping characteristic curves (tripping time vs. current). Fuses are considered as selective, if their characteristic curves do not touch or cross each other.

As an approximate general rule it can be assumed that fuses of the same rated characteristic are selective, if the rated current of the first fuse is at least 1.6 times the rated current of the following fuse.

Since circuit breakers always perform magnetic tripping in case of a short circuit, circuit breakers are only considered selective, if the following circuit breaker performs delayed tripping in case of a short circuit (so-called "selective circuit breakers").

2. Basic Principles of Power Supplies for Industrial Use

Characteristic curves in case of a short circuit on the output side

An occurring short circuit (t_1) causes a high short-time impulse current (I_p), the intensity of which is multiple times the rated current (I_N). This impulse current causes a fast thermal tripping of fuses and a magnetic tripping of circuit breakers.

In power supplies, this impulse current is produced by the discharge of the capacitors on the output side. After the capacitors are discharged (t_2), the power supply delivers its continuous short-circuit current (I_k).

The area under the impulse current curve is called the heat of fusion (I^2t) and represents the tripping energy of fuses.

Since short circuits will never have an ideal connection resistance of zero, it is not possible to give any general statement about the intensity of I_p and its duration. This mainly depends on the internal design of the power supply, the line resistances on the output side, the contact resistances of the terminals, the ambient temperature and whether it is a high-resistance or a low-resistance short circuit.

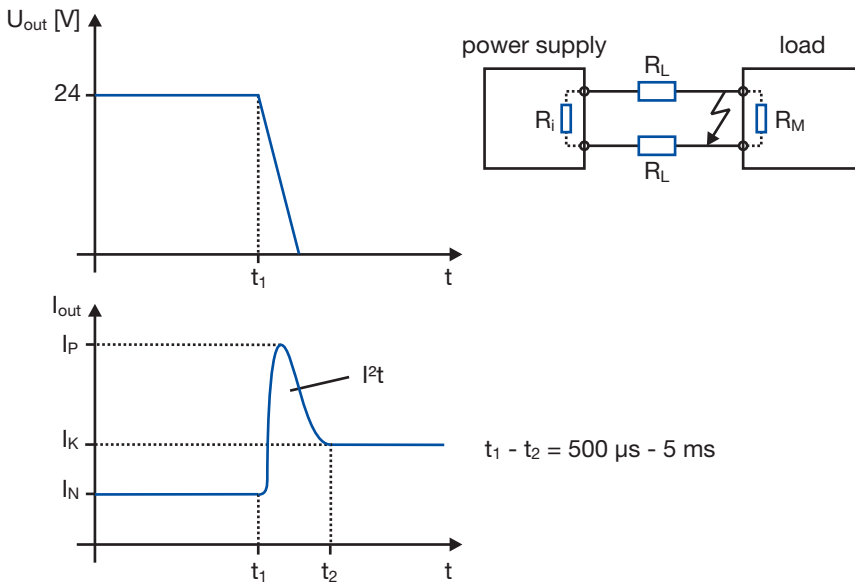

Figure 20 – Short-circuit behavior

2. Basic Principles of Power Supplies for Industrial Use

Selectivity example: PLC application

For specific PLC applications, the output voltage must not fall below 19 V since this would cause the PLC to start an emergency process for the purpose of data storage and stop the system controlled by the PLC. Consequently, the fuses have to trip before the output voltage of the power supply can fall below 19 V as a result of the short circuit.

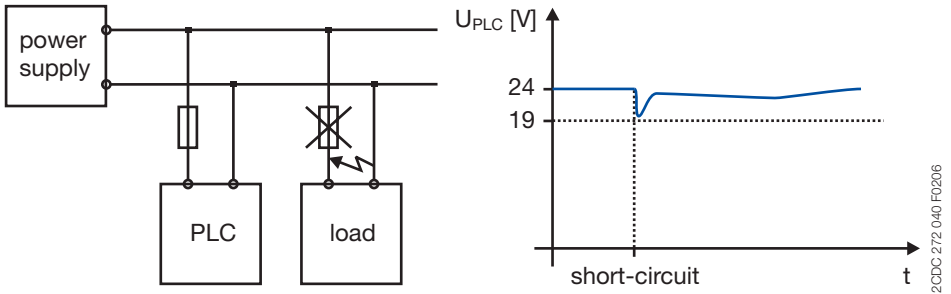

Figure 21 – Selectivity example (PLC)

Summary

Selectivity coordination always depends on the application and thus does not allow any general statements about the types of fuses and circuit breakers to be used.

Annex 5.1 contains a table listing which circuit breakers will provide reliable tripping at which conductor cross sections and line lengths in case of a short circuit. The values given in this table have been determined in the laboratory and must not be used for other applications. They are only intended as an aid to orientation instead.

Your ABB representative will be pleased to assist you in finding the best possible solution for your individual application.

2. Basic Principles of Power Supplies for Industrial Use

2.9. PFC (Power Factor Correction)

Since 1 January 2001, the European standard regarding the limits for harmonic current emissions (IEC/EN 61000-3-2) is in force. This standard defines the maximum allowed intensity of harmonic currents fed back into the supplying mains system. It is applicable for consuming devices with an active-power input between 75 and 100 W that are directly connected to the public electricity supply.

Power supplies for industrial applications often do not require PFC, since large installations are equipped with a central PFC, installed between the internal electric system and the public electricity supply.

2.9.1 Harmonics

All non-linear consuming devices, e.g. switch mode power supplies or rectifiers with capacitors, cause non-sinusoidal cyclic currents.

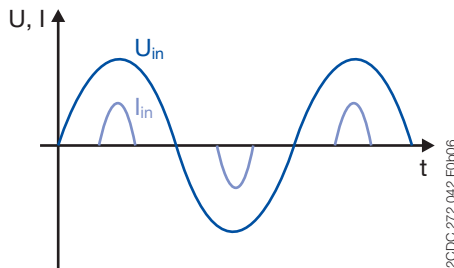

Figure 22 – Behavior of voltage and current

According to Fourier, each cyclic function can be separated into sinusoidal components. Consequently, a non-sinusoidal current can be separated into several superimposed sinusoidal currents the frequencies of which are integer multiples of the mains frequency. These so-called harmonics are fed back into the supplying mains system where they can have negative effects to the mains voltage and thus can cause malfunctioning of other sensitive consumers supplied by the same mains. Harmonic currents furthermore increase the power consumption of the power supplies since the energy of the harmonics (reactive power) cannot be utilized. This is why the supply lines have to be dimensioned with increased cross sections.

Minimizing the harmonic currents can be done using two methods:

- passive harmonic reduction (PFC) (→ 2.9.2)
- active harmonic reduction (PFC) (→ 2.9.3)

2. Basic Principles of Power Supplies for Industrial Use

2.9.2 Passive PFC

For passive PFC, a reactance coil is connected to the input circuit. This reactance coil buffers energy from the mains and thus reduces the current pulses. The lower the pulses, the less harmonics are produced.

The advantage of this solution is its easy implementation into existing circuitry, however, with the drawback that it is not able to reduce all harmonics.

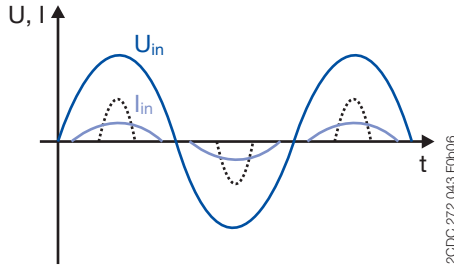

Figure 23 – Passive PFC

2.9.3 Active PFC

Active PFC is able to deliver considerably better results. In a very simplified consideration one could say that the actual power supply is preceded by another power supply that performs a regulation of the current consumption from the mains. This consumption is oriented towards the sinusoidal supply voltage.

Using this technology, it is possible to avoid the production of almost every kind of harmonics. However, the circuitry is much more complex than for passive PFC.

The ABB power supplies of the CP-C series are equipped with active PFC.

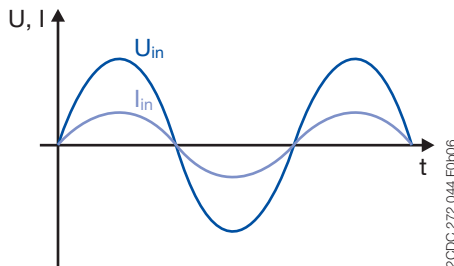

Figure 24 – Active PFC

3. ABB Product Range

3.1. Primary switch mode power supplies

It is hard to imagine today's power engineering and industrial automation without modern power supplies. ABB is a global partner in this field and well prepared to fulfill these requirements with its new product range of switch mode power supplies.

Of course, all switch mode power supplies from ABB have been ecologically beneficial, cost-effective and equipped with primary switch mode technology for a long time. This is innovative industrial electronics at the highest stage.

3.1.1 Product overview CP-E, CP-S and CP-C

ABB's product range of power supplies can be divided into three categories.

The power supplies of the CP-E series (E = "economy") are the ideal solution for basic applications without requirements for high currents.

The power supplies of the CP-S series (S = "standard") are designed for higher currents and represent a very economic solution due to their limited functionality.

The power supplies of the CP-C series (C = "comfort") cover the same output power range as the devices of the CP-S series but provide additional functionality and can be expanded by plug-in modules on the front side.

Features	CP-E	CP-S	CP-C
Wide-range input	•	• (5 A version)	•
Manual range selection	-	• (10 A & 20 A version)	-
Output voltage	5 V, 12 V, 24 V, 48 V	24 V	
Adjustable output voltage	•	-	•
Output current	0.625-3 A	5 A, 10 A, 20 A	
Efficiency	75-90 %	> 88 %	
Overload behavior	U/I (fold-forward) / hiccup	U/I (fold-forward)	
Temperature range	-10...+70 °C	-25...+70 °C	
Derating above	60 °C		
Parallel connection for increased capacity	-	-	•
Parallel connection for redundancy	•	•	•
PFC	-	-	•

Table 9 – Overview of features for CP-E, CP-S, CP-C

3. ABB Product Range

Approvals	CP-E	CP-S	CP-C
UL 508	•	•	•
UL 1604 (Class 1, Div. 2)	(in preparation)	•	•
UL 1310 (Class 2)	(some devices)		
UL 60950	•	•	•
GOST	•	•	•
CB scheme		•	•
CCC	•	•	•
Marks	CP-E	CP-S	CP-C
CE	•	•	•
C-TICK	•	•	•

Table 10 – Approvals and marks for CP-E, CP-S, CP-C

3. ABB Product Range

2CDC 271 015 F0606



3.1.2 CP-E

This series includes various versions with output voltages from 5 V DC up to 48 V DC at output currents from 0.625 A to 3 A. Their high efficiency of up to 89 % and their low power dissipation and heating allow the operation of these units without forced cooling. Despite the expansions in functionality it was possible to reduce the number of different types. Of course, all CP-E series power supplies are approved according to all world-wide applicable standards (cULus, IEC/EN 60950, etc.) and have the CE and the C-TICK sign applied.

Features

- Output voltages 5 V, 12 V, 24 V, 48 V DC
- Adjustable output voltages
- Output currents 0.625 A, 0.75 A, 1.25 A, 2.5 A, 3 A
- Power ranges 18 W, 30 W, 60 W
- Wide-range input 100-240 V AC (85-265 V AC, 90-375 V DC)
- High efficiency of up to 87-89 %
- Low power dissipation and heating
- Cooling by natural convection (no forced cooling by fan)
- Operating temperature range -10...+70 °C
- Open-circuit and overload protected, protected against permanent short circuits, automatic restart
- Integrated input fuse
- U/I output characteristic (fold-forward behavior in case of overload – no switch-off) for units > 18 W
- Isolating module CP-RUD for applications with "real" redundancy (refer to "Accessories")
- Status LED "OUTPUT OK"
- "DC OK" output (transistor) for 24 V units (> 18 W)

3. ABB Product Range

2CDC271.061.F0b04



3.1.3 CP-S

The CP-S series power supplies provide very high efficiency and higher output power than the CP-E series units. For the 10 A and 20 A units, the input voltage range can be selected using a switch on the front. The 5 A unit is equipped with a wide-range input.

Due to their integrated power reserve of up to 50 % of the rated output power, these units are able to start even high loads without any problems.

Features

- Current ranges 5 A, 10 A and 20 A
- Up to 50 % power reserve
- Fix output voltage of 24 V
- Wide-range input (5 A unit only)
- Input voltage adjustment by front-face selector switch (10 A and 20 A unit only)
- High efficiency of typically 88-89 %
- Low power dissipation and heating
- Open-circuit and overload protected, protected against permanent short circuits, automatic restart
- Integrated input fuse
- Parallel connection for redundancy purposes possible (unbalanced currents)
- Redundancy unit CP-A RU for real redundancy (refer to "Accessories")
- Control module CP-A CM pluggable onto CP-A RU (refer to "Accessories")
- Plug-in terminals for 5 A and 10 A units
- Status LED "OUTPUT OK"

3. ABB Product Range

2CDC 271 065 F0604



3.1.4 CP-C

The CP-C series power supplies provide extended functionality compared to the CP-S series. The power supplies can be further equipped with additional functionality by means of the innovative concept of expansion module slots on the front side. This saves space and enables easy retrofitting with an additional module since no further wiring is required to connect the module to the power supply.

The units are equipped with a wide-range input and thus can be operated with all common mains voltages, even in difficult environments with high supply voltage variations.

Like the CP-S series units, the CP-C series power supplies provide internal power reserves enabling the starting of high loads.

Features

- Current ranges 5 A, 10 A and 20 A
- Up to 50 % power reserve
- Adjustable output voltage from 22 to 28 V
- Wide-range input 85-264 V AC, 100-350 V DC
- High efficiency of typically 88-89 %
- Low power dissipation and heating
- Open-circuit and overload protected, protected against permanent short circuits, automatic restart
- Integrated input fuse
- Parallel connection possible for increased capacity and/or redundancy purposes (unbalanced currents)
- Redundancy unit CP-A RU for real redundancy (refer to "Accessories")
- Control module CP-A CM pluggable onto CP-A RU (refer to "Accessories")
- Plug-in terminals for 5 A and 10 A units
- Status LED "OUTPUT OK"
- Power factor correction (PFC) according to EN 61000-3-2
- Module slots on the front side for plug-in mounting of modules for functionality expansion (refer to "Accessories")

3. ABB Product Range

3.1.5 CL-LAS.SD...

The units of the CL-LAS.SD... range are power supplies in so-called modular design.

The CL-LAS.SD001 provides two different output voltages: 24 V and 12 V. The maximum output current is 0.25 A at 24 V and 20 mA at 12 V. The unit occupies a space of 4 MW.

The CL-LAS.SD002 provides an output voltage of 24 V and a maximum output current of 1.25 A. The unit occupies a space of 2 MW.

Features

- Current ranges 20 mA, 0.25 A, 1.25 A
- Output voltage 12 V, 24 V
- Wide-range input 85-264 V AC
- High efficiency of typically > 87 %
- Open-circuit and overload protected, protected against permanent short circuits
- Hiccup mode
- Operating temperature range -25...+55 °C
- Integrated input fuse
- Status LED "POWER"

3. ABB Product Range

3.2. Accessories

Apart from the usual requirements made for power supplies, there is an increasing need particularly for features regarding the monitoring of systems. ABB is able to meet these requirements with a new module series for monitoring purposes.

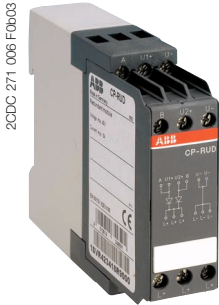

3.2.1 Redundancy unit CP-RUD for CP-E

The redundancy unit CP-RUD can be used to provide decoupling of two CP-E series power supplies for the purpose of real redundancy.

The maximum output current is 5 A which allows the connection of two power supplies with a current of 2.5 A each or one 5 A power supply.

If one power supply fails, the decoupling provided by this module prevents that this failure can affect the operation of the second power supply.



3.2.2 Messaging module CP-C MM for CP-C

The messaging module is plugged to the front side of CP-C series power supplies and thus enables the monitoring of this power supply.

The module is supplied with voltage by the power supply itself and therefore does not require any further wiring for voltage supply.

The "Remote off" input allows external remote controlled switch on/off for the power supply.

The module performs monitoring of the input and output voltages and indicates the present state by means of LEDs and relays.

The relays operate according to the closed-circuit principle which means that they are energized during normal operation and de-energized in case of a fault. This allows fault detection even in case of a total supply voltage loss.

3. ABB Product Range

2CDC 271 010 F0b06



3.2.3 Redundancy unit CP-A RU for CP-S/C

The redundancy unit for the CP-S/C series can be used to provide decoupling of two power supply units in order to set up a power supply system with real redundancy. The maximum output current must not exceed 40 A. This unit can be expanded by the control module CP-A CM.

2CDC 271 002 F0b05



3.2.4 Control module CP-A CM for CP-A RU

This expansion module enables comfortable input voltage monitoring for the redundancy unit CP-A RU. The threshold values for the output relays can be adjusted for each channel individually in the range of 14-28 V. The corresponding relay de-energizes, if the voltage in one channel falls below the adjusted threshold due to a fault (e.g. power supply failure, blown fuse). If the corresponding voltage is above the adjusted threshold value, the green LEDs "IN 1" and "IN 2" are on. The green LED "OUT" is on, if the output voltage is > 3 V.

4. Applications

This chapter contains hints for engineering and practical application examples.

4.1. Engineering

The questions to be answered when choosing a power supply are always the same. The most frequently asked questions are listed below. The answers serve as decision making aids in order to obtain best possible results for the respective application.

Most of the terms used below either have been discussed in chapter 2 or will be discussed in the following sections.

- **Which output voltage is required?**

The following voltages are commonly used in industrial applications: 5 V, 12 V, 15 V, 24 V and 48 V. Most applications require a supply voltage of 24 V.

- **How much load is applied?**

ABB power supplies are available for currents from 0.25 A up to 20 A. Therefore, suitable power supplies of the required output current class are available for almost every application without any need for oversizing.

- **What kind of load is applied?**

Particularly in case of difficult loads, e.g. motors or large contactors (refer to chapter 4.6 - "Supply for an AF185 contactor"), the power supply must provide sufficient reserves in order to be able to drive high inrush currents. All power supplies providing power reserves (e.g. CP-S/C series) are able to start such kinds of loads reliably without any need for oversizing.

- **Is it necessary to protect the installation against failure?**

In case of increased requirements regarding the availability, it is recommended to set up a redundant system. Using ABB's decoupling modules and optional control modules, such systems can be set up without problems.

For more detailed information, please refer to chapter "Parallel connection of power supplies".

4. Applications

- **Is it necessary to monitor the power supply?**

If the power supply is installed in a remote control cabinet, it is recommended to equip it with a messaging module in order to receive immediate notification in case of a possible failure.

This furthermore allows remote controlled switch-off for the power supply and thus additionally enables it for use in inaccessible areas.

All power supplies of the CP-C series can be equipped with the messaging module CP-C MM.

The 24 V power supplies of the CP-E series are equipped with a "DC OK" signalling output as a standard feature.

- **What kind of protection against accidental contact is required?**

The degree of protection of all ABB units is IP 20. This guarantees that there is no danger when devices are touched with the fingers. IP 20 is sufficient for use in control cabinets.

- **What are the conditions in the supplying mains?**

If large voltage variations are possible in the supplying mains, it is recommended to use power supplies with a wide-range input since these units are able to deliver stable output voltages even in case of input voltage variations.

The use of wide-range input power supplies is also recommended, if they are intended for world-wide use. This will reduce costs since only one power supply type per power class has to be kept in stock.

- **Is PFC required?**

Since 1 January 2001, all power supplies above 75 W, that can be directly connected to the mains, must meet the limit values for harmonic currents according to IEC/EN 61000-3-2.

However, PFC can also make sense when the power supply is not directly connected to the public electricity supply, e.g. if the electric system contains consumers that are sensitive to mains pollutions caused by the power supply.

All power supplies of the CP-C series are equipped with active PFC.

4. Applications

The following should be considered for the installation of power supplies:

- **Dimensioning of lines and line protection devices**

The supply lines have to be dimensioned sufficiently according to all possible currents of the application.

Please refer to the respective power supply data sheets for information about the current loads in the supply lines of the power supply and the corresponding conductor cross section recommendations.

On the output side it has to be considered that the output current in case of a short circuit can amount to 1.5 times the rated output current.

It is recommended to use circuit breakers in order to allow external switch-off for the power supplies. The tripping current of the circuit breakers has to be higher than the expected input current.

- **Mounting**

The minimum clearances towards other devices (e.g. CP-S/C: 1 cm on each side, 8 cm on top and bottom) and the installation instructions have to be observed in order to guarantee safe and reliable operation and to prevent excessive heating of the power supply.

All ABB power supplies are designed for DIN rail mounting. This allows quick and easy mounting and removal.

- **Ambient temperature**

All CP series power supplies from ABB can be operated without any restrictions of the output power up to an ambient temperature of 60 °C. From 60 °C to 70 °C, the maximum possible output power decreases steadily. Operation above 70 °C is not possible.

It has to be observed that the temperatures inside of control cabinets can be considerably higher than outside of the cabinet, depending on the environment and the installed components.

For more information about this, please refer to chapter "Effects of the ambient temperature to the output characteristic".

4. Applications

4.2. Output voltage adjustment

All power supplies of the series CP-E and CP-C allow an adjustment of the output voltage. The following subsections describe different applications that require an adjustment of the output voltage.

4.2.1 Compensation of line losses

Voltage drops on the secondary lines can be compensated by adjusting the output voltage. The following formula can be used to calculate the voltage drop on the lines:

$$\Delta U = \frac{I \cdot \rho \cdot (2 \cdot l)}{A} \quad [1]$$

Where ΔU = voltage drop in [V]

I = current in [A]

ρ = resistivity (copper: $0,0178 \frac{\Omega \cdot m^2}{m}$)

l = line length in [m] (multiplied by 2 to consider feeding and return wire)

A = conductor cross section in [mm²]

Example:

The power supply feeds a current of 10 A to a load that is connected by a cable with a length of 5 m and a conductor cross section of 2.5 mm².

The voltage drop according to [1] is as follows:

$$\Delta U = \frac{10 \text{ A} \cdot 0,0178 \frac{\Omega \cdot m^2}{m} \cdot (2 \cdot 5 \text{ m})}{2,5 \text{ m}^2 \cdot m} = 0,712 \text{ V}$$

The output voltage of the power supply has to be increased by this value in order to have the rated voltage available at the load.

4. Applications

4.2.2 Balancing of power supplies

When used in parallel connection (refer to figure below), the power supplies must deliver exactly the same output voltage. They require output voltage balancing.

Proceed as follows to balance the output voltages:

- 1) Adjust the desired output voltage at one power supply using a voltmeter (e.g. to 24.0 V).

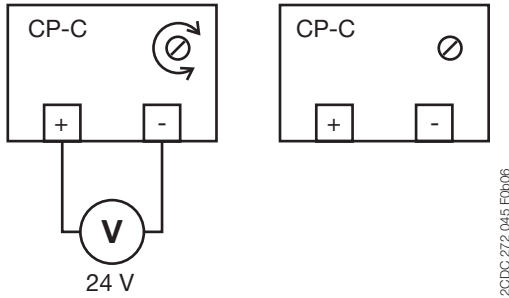

Figure 25 – Output voltage balancing of power supplies (1)

- 2) Then you have to measure the voltage difference between the power supplies. For this purpose, connect the voltmeter to the plus terminals of both power supplies and apply a direct wire connection between the minus terminals of the power supplies. Then, adjust the output voltage of the second power supply until the voltmeter displays a voltage difference of 0 V.

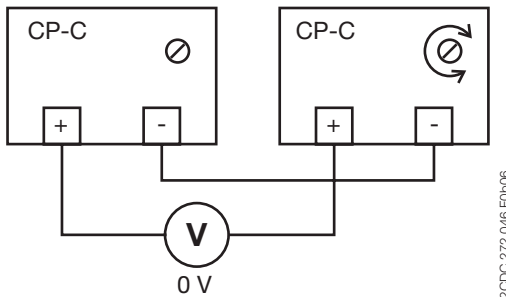

Figure 26 – Output voltage balancing of power supplies (2)

The output voltage is now balanced and the power supplies can be used in parallel connection. For further details, please refer to the following chapter.

4. Applications

4.3. Parallel connection of power supplies

There are two reasons for a parallel connection of power supplies:

- Increase of capacity
- Fail-safety, redundancy

Warning:

Parallel connection is only allowed for power supplies that are specified for this use in their data sheet!

4.3.1 Parallel connection of power supplies for increased capacity

An increase of the output power can be obtained by connecting power supplies in parallel. This can be necessary, if the current required by the load is higher than a single power supply can deliver, for example after the expansion of an existing installation.

The following prerequisites have to be fulfilled when connecting power supplies in parallel for the purpose of increased capacity:

- Parallel connection is only allowed for identical power supplies.
- The power supplies have to be switched on simultaneously, e.g. by means of a common master switch.
- The following has to be observed when connecting the power supplies in order to prevent different voltage drops on the supply lines or at the terminals which would lead to unbalanced load at the common connection point (refer to "Current balance"):
 - Identical lengths of the supply lines.
 - Identical conductor cross sections of the supply lines.
 - Terminal screws have to be fastened with the same torque to guarantee equal contact resistances.
- The output voltages of the power supplies must not differ by more than 50 mV. Otherwise, safe operation is not possible (refer to "Balancing of power supplies").

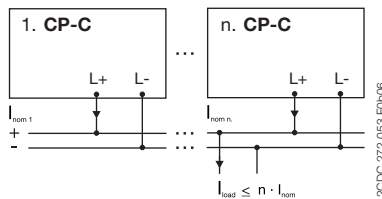
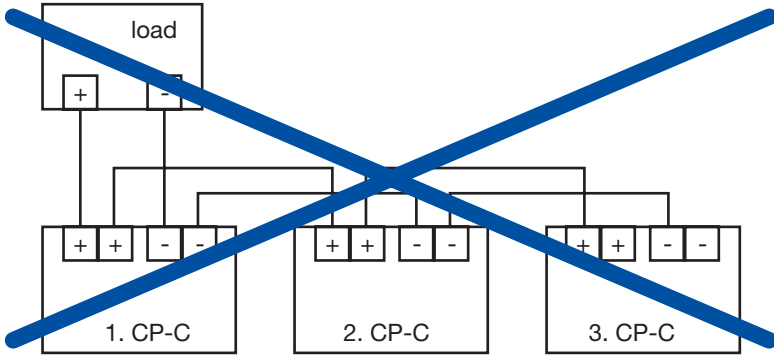

Figure 27 – Increased capacity

4. Applications

Important:

The devices must not be connected directly to each other! This could lead to an overload of the terminals since the terminals are dimensioned for the maximum output current of a single power supply only. Always use a common connection point!



2CDC 272 047 F0206

Figure 28 – Incorrect wiring for increased capacity

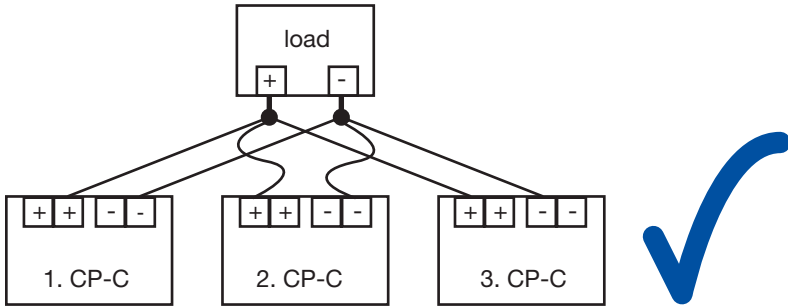

2CDC 272 048 F0206

Figure 29 – Correct wiring for increased capacity

4. Applications

4.3.2 Parallel connection of power supplies for redundancy

The term redundancy generally denotes the existence of several objects that are identical in functionality, content or nature. In case of industrial systems, this means for example that several power supplies are connected in parallel in order to guarantee continuous operation of the system if one power supply fails.

In this context, the term "n+1 redundancy" is often used, meaning that one more device is used than required for normal trouble-free operation.

Two modes have to be distinguished for the parallel connection of power supplies for the purpose of redundancy:

- a) Simple redundancy
- b) True redundancy

a) Simple redundancy

For simple redundancy, the power supplies are connected in parallel like for the increase of capacity. However, in case of redundancy, the current required by the load must not exceed the maximum output power of one single power supply (in case of "1+1 redundancy").

If one power supply fails, the load current is supplied by the other power supply. This is why it is recommended to connect the primary sides of the power supplies to different phases of the mains in order to obtain continuous operation of the system, if one phase fails.

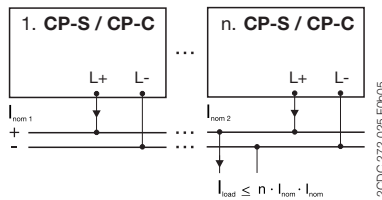

Figure 30 – Simple redundancy

4. Applications

b) True redundancy

For true redundancy it is necessary to provide decoupling of the individual power supplies. Otherwise, the failed power supply could possibly act as a load for the other power supply or, in the worst case, cause a short circuit on the secondary side resulting in a failure of the second power supply.

Decoupling of the power supplies has to be performed by connecting decoupling diodes (so-called O-ring diodes) to the secondary outputs. These diodes prevent mutual loading of the power supplies in case of a fault and thus guarantee continuous supply.

For the setup of redundant power supply systems, ABB offers two redundancy units, the CP-RUD (for output currents of up to 5 A) and the CP-A RU (for output currents of up to 40 A). The inputs of these units are connected to the terminals L+ and L- of the power supplies (many other manufacturers often consider L+ only). The loads are supplied directly from the outputs of the redundancy unit.

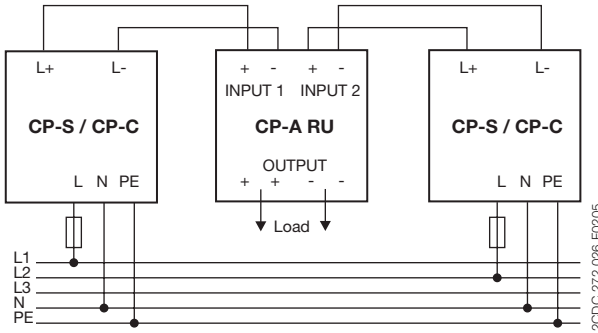

Figure 31 – True redundancy using a CP-A RU

4. Applications

4.3.3 Current balance

Current balance means that all power supplies involved in a parallel connection deliver the same share of the entire load current.

Balanced sharing of the current is of particular importance, if parallel connection is used for the purpose of capacity increase. In case of unbalanced loading, the device bearing the higher load would be exposed to increased aging and thus possibly fail prematurely. As a result, the other power supplies involved in the parallel connection would become overloaded resulting in a total failure of the entire installation.

Origination of current unbalances

Unbalanced sharing of the load currents can for example be caused by slightly different output voltages of the involved units.

For example, if one power supply in a parallel connection delivers 24.3 V and the other only 24.0 V, the higher voltage is also effective at the output of the power supply delivering the lower voltage. In this case, the regulator of the power supply delivering only 24.0 V will prevent the output of current. As a result, the unit delivering the higher voltage will supply the entire load current until it enters its current limiting mode and, as a result, decreases its output voltage (refer to "Short-circuit and overload protection (output characteristics)"). Since the output voltage of the first power supply has decreased now, the regulator of the second power supply will allow the output of current and supply the remaining load current.

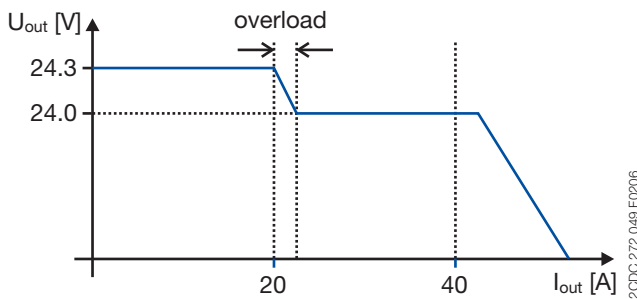

Figure 32 – Current unbalance

As a result, the first power supply permanently operates in current limiting and is thus exposed to considerably higher aging than the other power supply.

There are two basic approaches to obtain current balance:

- Passive current balancing
- Active current balancing

4. Applications

a) Passive current balancing

For passive current balancing, the output characteristics of the power supplies are changed slightly: An increase of the current causes a slight decrease of the voltage. In parallel operation, this leads to a fixed operating point.

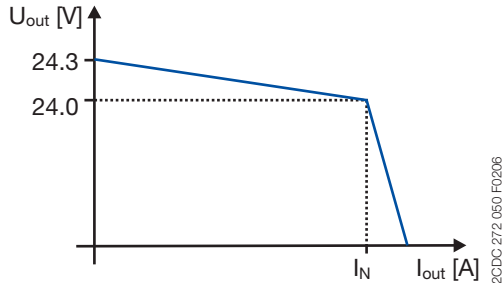

Figure 33 – Passive current balancing

Transferred to the example mentioned above, this has the following effect: At the beginning, the power supply with the higher output voltage supplies the entire load current until its output voltage (which is slowly decreased due to the increase of the current) reaches the rated voltage of the other power supply. Then, the load current is supplied by both power supplies. One disadvantage of this method is that the load is not shared equally to the power supplies. The smaller the difference of the output voltages, the better the result. This is why manual balancing of the output voltages is recommended. It is furthermore recommended to use secondary lines of identical lengths and identical conductor cross sections.

b) Active current balancing

In case of active current balancing, the device is equipped with additional terminals to connect the individual power supplies to each other. Via this connection, the power supplies perform mutual regulation with the result that each power supply delivers exactly the same current. A major advantage of this method is that no exact balancing of the output voltages is required and that the output lines to the load can be of different lengths.

4. Applications

4.4. Series connection of power supplies

All ABB power supplies can be connected in series for the purpose of voltage doubling. However, this is restricted to the series connection of two power supplies of the same type and with identical output power.

Depending on the specification of the reference ground on the output side, the following voltages can be obtained using two 24 V power supplies: +48 V, -48 V and ± 24 V.

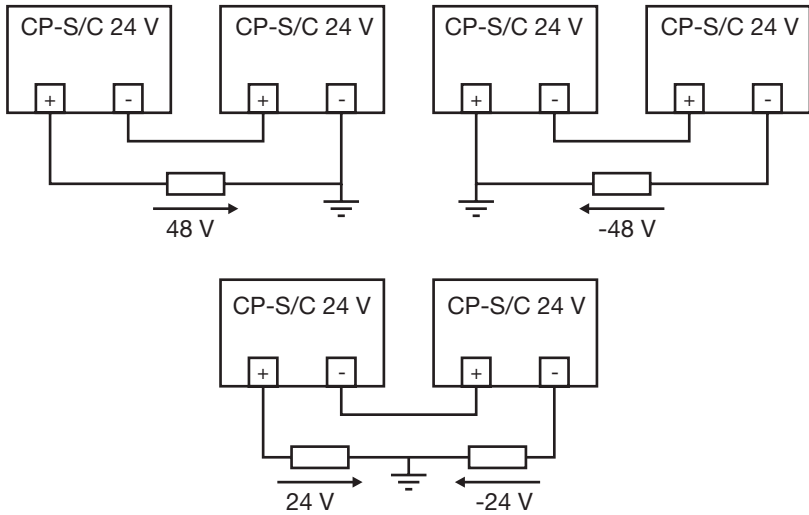

2CDC272 051 F0b06

Figure 34 – Series connection of power supplies

Note:

When connecting power supplies in series, the permitted SELV voltage of 60 V DC can be exceeded possibly in case of a fault!

4. Applications

4.5. Monitoring functions

The following sections describe the possible use of the ABB monitoring modules using various example applications.

4.5.1 Monitoring of a single power supply using a CP-C with a CP-C MM

Action in case of a fault: Output of a fault indication.

If both relays are de-energized, no supply voltage is available at the power supply or the power supply is defective or switched off.

If the signaling relay for the "OUTPUT OK" indication is de-energized and the "INPUT OK" relay is energized, either a short circuit exists on the secondary side that caused the power supply to decrease its output voltage or the power supply itself is defective and thus not able to supply any output voltage.

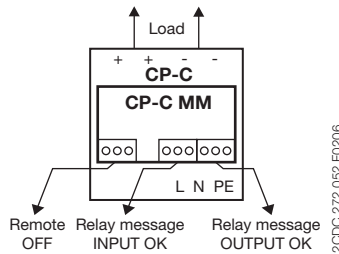

Figure 35 – CP-C with a CP-C MM

Remark:

The messaging module is suitable for monitoring a single power supply! If power supplies are connected in parallel, the redundancy unit CP-A RU has to be used together with the monitoring module CP-A CM (refer to next subsection).

4. Applications

4.5.2 Monitoring of two power supplies using a CP-A RU with a CP-A CM

Action in case of a fault: Output of a fault indication.

If both relays are de-energized, the voltages of both channels are below the adjusted threshold value (e.g. 20 V). This could indicate that both power supplies failed or were switched off or that an overload exists on the secondary side. A short-time de-energization of both relays followed by the normal state with both relays energized could indicate that the connected load has reached its normal operation again after a switch-on process. If only one relay de-energizes, one power supply has possibly failed or has been switched off and, as a result, redundancy is no longer given.

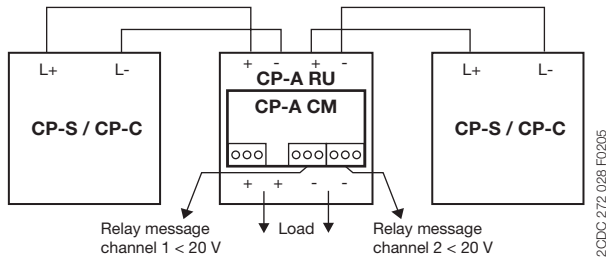

Figure 36 – CP-A RU with a CP-A CM

4. Applications

4.5.3 Monitoring of one power supply using a CP-A RU with a CP-A CM

Action in case of a fault: Switch-over to an alternative power supply.

The following application example shows the implementation of a switch-over functionality to an alternative power supply (e.g. a battery) in the event of a fault in the monitored power supply unit.

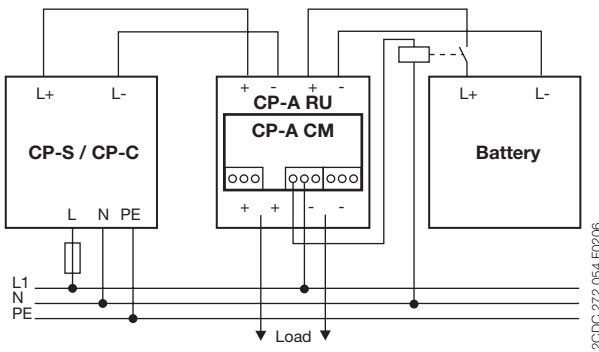

Figure 37 – Application example: CP-A RU with a CP-A CM

A power supply and a battery are connected to a redundancy unit CP-A RU equipped with a CP-A CM monitoring unit. During normal operation, the load connected to the redundancy unit is supplied by the power supply unit. If the output voltage of the power supply unit drops below the adjusted threshold value due to an internal fault or due to a supply voltage failure, the monitoring module CP-A CM will recognize this and de-energize the corresponding relay. This connects the battery to the redundancy unit. As a result, the power supply of the load is provided by the battery. If the power supply unit returns to normal operation within the adjusted output voltage tolerances, the battery is disconnected from the redundancy unit again.

4. Applications

4.6. Application example

4.6.1 Supply for an AF185 contactor

Contactor of the type AF185 are used for example to switch high loads, such as motors. To energize this type of contactors (t_1), a high inrush current is required until the magnet has closed (t_2). The power supply has to be able to deliver this high inrush current, the intensity of which can exceed the rated current of the power supply multiple times. If these power reserves are not available, the magnet inside the contactor will close slower which can result in contact bonding (slow closing can cause an electric arc between the contacts and thus lead to contact welding).

For this special application, ABB could help the customer to find the ideal power supply in order to obtain the best possible result.

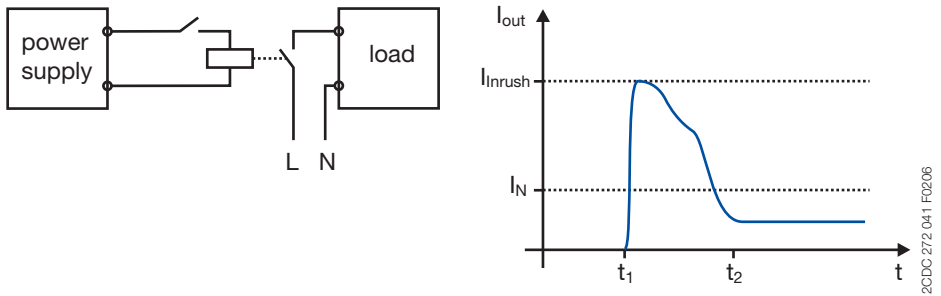

Figure 38 – Application example: Contactor

20DC 27/2 041 F0206

5. Appendix

5.1. Selectivity tables for section 2.8.4

Power supply		CP-S 24/5.0 CP-C 24/5.0																							
		0.75 mm ²						1.0 mm ²						1.5 mm ²						2.5 mm ²					
Conductor cross section	Total length	4	6	8	10	20	40	4	6	8	10	20	40	4	6	8	10	20	40	4	6	8	10	20	40
		Length [m] (both directions)		2+	3+	4+	5+	10+	20+	2+	3+	4+	5+	10+	20+	2+	3+	4+	5+	10+	20+	2+	3+	4+	5+
Line resistance [mΩ]		96	144	192	240	480	960	72	108	144	180	360	720	48	72	96	120	240	480	28	42	56	70	140	280
Miniature circuit breakers																									
Z1		X	X	X	X	X	X	X	X	X	X	X	X	X	X	X	X	X	X	X	X	X	X	X	X
Z1.6		X	X	X	X	X	X	X	X	X	X	X	X	X	X	X	X	X	X	X	X	X	X	X	X
Z2		X	X	X	X	X	X	X	X	X	X	X	X	X	X	X	X	X	X	X	X	X	X	X	X
Z3		X	X	X	X	X	X	X	X	X	X	X	X	X	X	X	X	X	X	X	X	X	X	X	X
Z4		X	X	X	X	X	X	X	X	X	X	X	X	X	X	X	X	X	X	X	X	X	X	X	X
Z6		X	X	X	X	X	X	X	X	X	X	X	X	X	X	X	X	X	X	X	X	X	X	X	X
Z8		X	X	X	X	X	X	X	X	X	X	X	X	X	X	X	X	X	X	X	X	X	X	X	X
B6		X	X	X	X	X	X	X	X	X	X	X	X	X	X	X	X	X	X	X	X	X	X	X	X
C1.6		X	X	X	X	X	X	X	X	X	X	X	X	X	X	X	X	X	X	X	X	X	X	X	X

Legend: x: Circuit breaker trips

o: Thermal tripping of the circuit breaker

5. Appendix

Power supply		CP-S 24/10.0 CP-C 24/10.0																														
Conductor cross section		0.75 mm ²						1.0 mm ²						1.5 mm ²						2.5 mm ²												
Total length	Length [m] (both directions)	4	6	8	10	20	40	4	6	8	10	20	40	4	6	8	10	20	40	4	6	8	10	20	40	4	6	8	10	20	40	
Line resistance [mΩ]		96	144	192	240	480	960	72	108	144	180	360	720	48	72	96	120	240	480	28	42	56	70	140	280							
Miniature circuit breakers																																
Z1		X	X	X	X	X	X	X	X	X	X	X	X	X	X	X	X	X	X	X	X	X	X	X	X	X	X	X	X	X	X	
Z1.6		X	X	X	X	X	X	X	X	X	X	X	X	X	X	X	X	X	X	X	X	X	X	X	X	X	X	X	X	X	X	
Z2		X	X	X	X	X	X	X	X	X	X	X	X	X	X	X	X	X	X	X	X	X	X	X	X	X	X	X	X	X	X	
Z3		X	X	X	X	X	0	X	X	X	X	X	X	X	X	X	X	X	X	X	X	X	X	X	X	X	X	X	X	X	X	
Z4		X	X	X	X	X	0	X	X	X	X	0	X	X	X	X	X	X	X	X	X	X	X	X	X	X	X	X	X	X	X	
Z6		X	X	X	X	X	0	X	X	X	X	0	X	X	X	X	X	X	X	X	X	X	X	X	X	X	X	X	X	X	X	
Z8		0	0	0	0	0	0	0	0	0	0	0	0	0	0	0	0	0	0	0	0	0	0	0	0	0	0	0	0	0	0	
B6		0	0	0	0	0	0	0	0	0	0	0	0	0	0	0	0	0	0	0	0	0	0	0	0	0	0	0	0	0	0	
C1.6		0	0	0	0	0	0	0	0	0	0	0	0	X	0	0	0	0	0	X	0	0	0	0	0	X	0	0	0	0	0	

Legend: x: Circuit breaker trips
 o: Thermal tripping of the circuit breaker

5. Appendix

Power supply		CP-S 24/20.0 CP-C 24/20.0																													
Conductor cross section		0.75 mm ²						1.0 mm ²						1.5 mm ²						2.5 mm ²											
Total length	Length [m] (both directions)	4	6	8	10	20	40	4	6	8	10	20	40	4	6	8	10	20	40	4	6	8	10	20	40	4	6	8	10	20	40
		2+	3+	4+	5+	10+	20+	2+	3+	4+	5+	10+	20+	2+	3+	4+	5+	10+	20+	2+	3+	4+	5+	10+	20+	2+	3+	4+	5+	10+	20+
Line resistance [mΩ]		96	144	192	240	480	960	72	108	144	180	360	720	48	72	96	120	240	480	28	42	56	70	140	280						
Miniature circuit breakers																															
Z1		X	X	X	X	X	X	X	X	X	X	X	X	X	X	X	X	X	X	X	X	X	X	X	X	X	X	X	X	X	X
Z1.6		X	X	X	X	X	X	X	X	X	X	X	X	X	X	X	X	X	X	X	X	X	X	X	X	X	X	X	X	X	X
Z2		X	X	X	X	X	X	X	X	X	X	X	X	X	X	X	X	X	X	X	X	X	X	X	X	X	X	X	X	X	X
Z3		X	X	X	X	X	X	X	X	X	X	X	X	X	X	X	X	X	X	X	X	X	X	X	X	X	X	X	X	X	X
Z4		X	X	X	X	X	X	X	X	X	X	X	X	X	X	X	X	X	X	X	X	X	X	X	X	X	X	X	X	X	X
Z6		X	X	X	X	X	X	X	X	X	X	X	X	X	X	X	X	X	X	X	X	X	X	X	X	X	X	X	X	X	X
Z8		X	X	X	X	X	X	X	X	X	X	X	X	X	X	X	X	X	X	X	X	X	X	X	X	X	X	X	X	X	X
Z10		X	X	X	X	X	X	X	X	X	X	X	X	X	X	X	X	X	X	X	X	X	X	X	X	X	X	X	X	X	X
B6		X	X	X	X	X	X	X	X	X	X	X	X	X	X	X	X	X	X	X	X	X	X	X	X	X	X	X	X	X	X
C1.6		X	X	X	X	X	X	X	X	X	X	X	X	X	X	X	X	X	X	X	X	X	X	X	X	X	X	X	X	X	X

Legend: x: Circuit breaker trips
 o: Thermal tripping of the circuit breaker

5. Appendix

5.2 List of figures

Figure 1 – Simplified consideration of the electrical design.....	4
Figure 2 – Overview of power supply types.....	5
Figure 3 – Unregulated power supply	6
Figure 4 – Linearly regulated power supply	7
Figure 5 – Primary switch mode power supply.....	8
Figure 6 – Secondary grounding.....	12
Figure 7 – Ground fault.....	12
Figure 8 – Short circuit to earth	12
Figure 9 – Hiccup mode	22
Figure 10 – Rectangular current limiting	23
Figure 11 – Triangular current limiting.....	23
Figure 12 – U/I characteristic with power reserves	24
Figure 13 – Derating diagrams.....	25
Figure 14 – Derating example.....	26
Figure 15 – Thermal switch-off	27
Figure 16 – Series selectivity.....	30
Figure 17 – Parallel selectivity	31
Figure 18 – Tripping characteristic curve of a fuse	32
Figure 19 – Tripping characteristic curve of a circuit breaker (B characteristic) .	33
Figure 20 – Short-circuit behavior.....	34
Figure 21 – Selectivity example (PLC)	35
Figure 22 – Behavior of voltage and current.....	36
Figure 23 – Passive PFC	37
Figure 24 – Active PFC.....	37
Figure 25 – Output voltage balancing of power supplies (1)	50
Figure 26 – Output voltage balancing of power supplies (2)	50
Figure 27 – Increased capacity	51
Figure 28 – Incorrect wiring for increased capacity	52
Figure 29 – Correct wiring for increased capacity	52
Figure 30 – Simple redundancy	53
Figure 31 – True redundancy using a CP-A RU.....	54
Figure 32 – Current unbalance	55
Figure 33 – Passive current balancing	56
Figure 34 – Series connection of power supplies.....	57
Figure 35 – CP-C with a CP-C MM	58
Figure 36 – CP-A RU with a CP-A CM.....	59
Figure 37 – Application example: CP-A RU with a CP-A CM	60
Figure 38 – Application example: Contactor	61

5. Appendix

5.3 Index

A		F	
Ambient temperature	25	Fold-back characteristic	22
Approvals	17	Fold-forward characteristic	24
CB scheme	17	Fuses	30, 31, 32
CCC	17	Fusing	29
CSA	17	Input fusing	29
CSA 22.2/213	18	Output fusing	29
cULus	17	G	
cURus	17	Ground fault	12
GOST	17	H	
UL 1310 (class 2 power supply) ...	18	Harmonic reduction	36
UL 1604 (Class I, Div. 2)	18	Harmonics	36
UL 508	17, 19	Hiccup mode	22
UR	17	I	
Aurorange	21	Increased capacity	51
B		Input side	4
Balancing of power supplies	50	Insulation	11
C		Basic insulation	11
Class of protection	14	Double insulation	11
Protection class 0	14	Functional insulation	11
Protection class I	14	Reinforced insulation	11
Protection class II	14	Supplementary insulation	11
Protection class III	14	IP code	14
Compensation of line losses	49	M	
Conductor cross section	29	Manual range selection	21
Current-carrying capacities	29	Marks	17
Current balance	55	C-Tick	18
Current balancing	56	CE	18
Active current balancing	56	Monitoring functions	58
Passive current balancing	56	O	
Current limiting	23	Open-circuit protection	28
Rectangular current limiting	23	Output characteristic	22, 25, 26
Triangular current limiting	23	Output side	4
D		Overload protection	22
Degree of protection	14	Overvoltage protection	28
Derating	25, 26, 38	P	
E		Parallel connection of power supplies	51
Electrical design	4	PELV	13
Electrical isolation	11	PFC (Power Factor Correction) ...	20, 36
EMC	20	Active PFC	37
Engineering	46	Passive PFC	37
		Pollution degree	16

5. Appendix

Power failure buffering.....	4, 28	IEC/EN 61000-6-... (EMC).....	20
Power supply types	5	IEC/EN 61140 (Class of protection) ..	14
Linearly regulated power supplies...7		IEC/EN 61204 (Product standard) 19	
Primary switch mode power			
supplies	8	T	
Secondary switch mode power		Thermal protection.....	27
supplies	9	U	
Unregulated power supplies.....	6	U/I characteristic.....	23
Protection against accidental contact.....	14, 15	U/I characteristic with power reserve..	24
Protection against ingress of water ...	15	W	
Protective extra low voltage	13	Wide-range input	21
Protective functions	22		
Pulse width modulation.....	8		
R			
Reactive power.....	36		
Redundancy	53		
Simple redundancy	53		
True redundancy	54		
Resistance to reverse feed.....	28		
S			
Safe isolation	11		
Safety	11		
Safety extra low voltage.....	13		
Secondary grounding.....	12		
Selectivity.....	30		
Parallel selectivity	31		
Series selectivity.....	30		
SELV.....	13		
Series connection of power supplies..	57		
Short-circuit protection	22		
Standards	19		
73/23/EEC (Low Voltage Directive) ...	19		
89/336/EEC (EMC directive).....	19		
DIN EN 60529 (IP code)	14		
EN 50178 (Electrical isolation)	11		
EN 50178 (Electrical safety)....	16, 19		
EN 55022 IEC/CISPR 22 (EMC) ...	20		
IEC/EN 60950 (Electrical safety)	11, 13, 19		
IEC/EN 61000-3-2 (PFC).....	20		
IEC/EN 61000-4-... (EMC).....	20		



ABB STOTZ-KONTAKT GmbH

Export Department

Eppelheimer Straße 82

69123 Heidelberg

Germany

www.abb.com/lowvoltage → Control Products → Power Supplies

Publication No. 2CDC 114 048 M0201 (02/07)
Printed in the Federal Republic of Germany