

- **The flowrate or the total volume of single phase steam, gases and liquids can be metered with these instruments over a wide flow range, independent of the properties of the fluid**
- **No moving parts, no wear, no maintenance**
- **Ex-Design**
 - II 2G EEx ia/ib IIC T4
 - II 2G EEx d [ib] IIC T6
 - II 3G EEx nA [L] IIC T4
 - II 2D T85 °C ... Tmed IP67
 - FM Approval Class I DIV 1
- **Easy Installation and Start-up**
 - Simply install in pipeline and complete the electrical connections
- **Converter with DSP-Technology**
 - Most modern digital filter techniques assure accurate detection of even the weakest sensor signals
- **Operate without opening the housing using a Magnet Stick**
- **Contact Output**
 - Can be used as an alarm or pulse output
- **Optional integrated Pt100 used as a temperature monitor or for saturated steam calculations**
- **Very short conditioning sections for FS4000**



**2-Wire Compact Design Meter
Digital-Signal-Processor
Converter Technology**

Operating Principle

Vortex Flowmeter

The operation of the Vortex Flowmeter is based on the Karman Vortex Street principle. As a fluid flows past a shedder body, vortices are alternately formed on both sides. These vortices are shed due to the flow stream forming a vortex street (Karman Vortex Street) as shown in (Fig. 1).

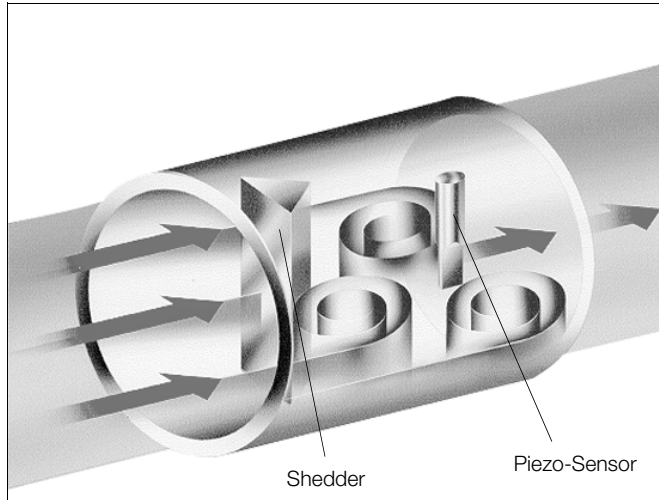

Fig. 1: Principle of Operation FV4000

The frequency f of the vortex shedding is proportional to the flow velocity v and inversely proportional to the width of the shedder d :

$$f \propto N \cdot St \times \frac{v}{d}$$

St , the Strouhal Number is a dimensionless number which defines the quality of the vortex flowrate measurements.

When the shedder is dimensioned appropriately, the Strouhal No. St is constant over a wide Reynolds No. range (Fig. 2).

$$Re = \frac{v \times D}{\nu}$$

ν = kinematic viscosity
 D = meter pipe diameter

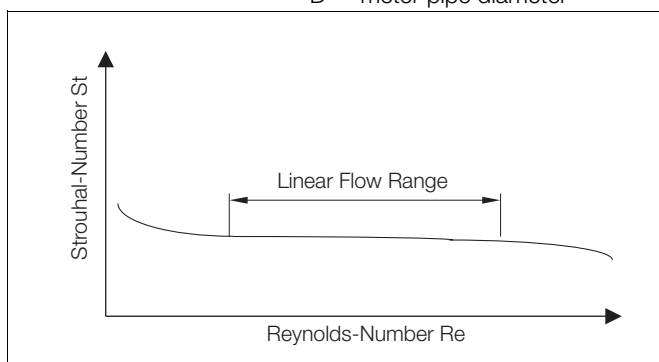

Fig. 2: Strouhal No. / Reynolds No. Relationship

The vortex shedding frequency to be measured is therefore only a function of the flow velocity and is independent of the fluid density and viscosity.

The local pressure changes associated with the vortex shedding are detected by a Piezo-Sensor and converted into electrical pulses representing the vortex shedding frequency.

This flowrate proportional frequency signal coming from the flowmeter primary is processed in the converter.

Swirl Flowmeter

The inlet guide body forces the entering fluid to rotate. In the center of this rotation a vortex core is formed which is forced into a secondary spiral shaped rotation by the backflow (Fig. 3).

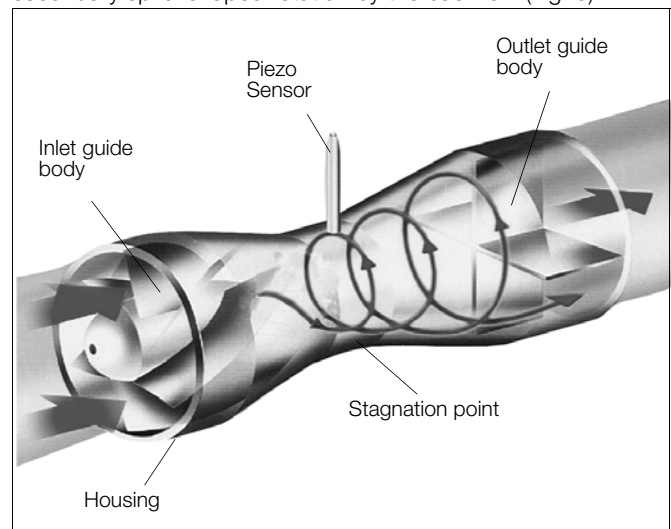
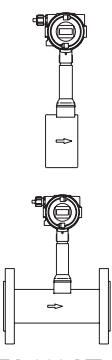
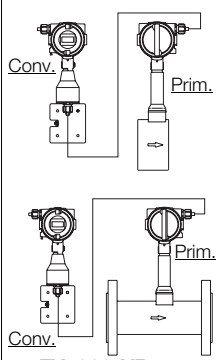
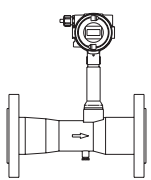
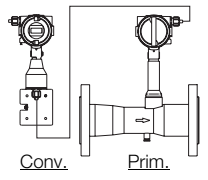

Fig. 3: Principle of Operation FS4000

The frequency of this secondary rotation is proportional to the flowrate and for an optimally designed internal geometry is linear over a wide flow range. This frequency is measured by a Piezo Sensor.

The flowrate proportional frequency signal coming from the flowmeter primary is processed in the converter.

Version Overview

					
		FV4000-VT4 (TRIO-WIRL VT)	FV4000-VR4 (TRIO-WIRL VR)	FS4000-ST4 (TRIO-WIRL ST)	FS4000-SR4 (TRIO-WIRL SR)
Accuracy	Liquids	$\leq \pm 0.75\%$ of rate at reference conditions		$\leq \pm 0.5\%$ of rate at reference conditions	
	Gases and Steam	$\leq \pm 1\%$ of rate at reference conditions			
Reproducibility		$DN15[1/2"] \leq \pm 0.3\%$ of rate $DN15-DN150[1/2"-6"] \leq \pm 0.2\%$ of rate from $DN200[8"] \leq \pm 0.25\%$ of rate		$DN15[1/2"] \leq \pm 0.3\%$ of rate from $DN20[3/4"] \leq \pm 0.2\%$ of rate	
Allowable Viscosity for liquids (> 7.5 mPas requires a field calibration in the FS4000)		$DN15[1/2"] \leq 4$ mPas $DN25[1"] \leq 5$ mPas from $DN40[1-1/2"] \leq 7.5$ mPas		$DN15[1/2"]$ to $DN32[1-1/4"] \leq 5$ mPa s $DN40[1-1/2"]$ to $DN50[2"] \leq 10$ mPa s from $DN80[3"] \leq 30$ mPa s	
Typical flow range		1:20		1:25	
Typical in-/outlet sections		15 x D / 5 x D		3 x D / 1 x D	
Flowmeter Primary					
Process connections	Flanges (DIN, ANSI, JIS)	DN 15 to DN 300 (1/2" to 12")		DN 15 to DN 400 (1/2" to 16")	
	Wafer Design (DIN, ANSI, JIS)	DN 15 to DN 150 (1/2" to 6")		-	
Sensor design	Single sensor	yes, optional with integrated temperature measurement			
	Double sensor ($\geq DN50[2"]$)	yes, optional with integrated temperature measurement			
Fluid temperature	Standard	-55 °C to 280 °C		-55 °C to 280 °C	
	High temperature ($\geq DN25[1"]$)	-55 °C to 400 °C		-	
Protection Class		IP 67 / NEMA 4X		IP 67 / NEMA 4X	
Materials	Sensor	1.4571[316Ti] opt. Hast. C/Titanium		1.4571[316Ti] opt. Hast. C/Titanium	
	In-/outlet guide body	-		1.4571[316Ti] opt. Hast. C	
	Shedder	1.4571[316Ti] opt. Hast. C		-	
	Meter housing	1.4571[316Ti] opt. Hast. C		1.4571[316Ti] opt. Hast. C	
	Sensor seals	Graphite, Kalrez, Viton, PTFE		Graphite, Kalrez, Viton, PTFE	
Only FVR4000 or FSR4000	2" pipe mount for converter	-	yes, optional	-	yes, optional
	Signal cable length betw. primary & converter	-	max. 10 m	-	max. 10 m
Converter					
Supply power	For analog output 4-20 mA	14-46 V (EEx ib ≤ 28 V)			
	For PROFIBUS PA and FOUNDATION Fieldbus	$I < 10$ mA (9 - 32 V; EEx ia ≤ 24 V)			
Self monitoring		yes			
Display	2 x 8 char. / 2 x 16 char.	Local indication / totalization with Magnet Stick operation Configure using HART-Protocol / PROFIBUS PA / FOUNDATION Fieldbus selectable yes, for storing converter parameters and flowmeter primary calibration data			
External FRAM		yes, for storing converter parameters and flowmeter primary calibration data			
Contact output	(Optocoupler is standard) NAMUR-Contact (EEx ia/ib)	Can be configured as an limit contact (flowrate, temperature), alarm or pulse output			
Sat. steam calc's/temperature compensation		yes, when a temperature sensor is installed			
Communication		HART-Protocol, PROFIBUS PA (Profile 3.0), FOUNDATION Fieldbus			
Approvals / Certificates (Approval specifications see Ex-Chapter starting on Page 32)					
Ex-Design (communication capable)					
HART	Ex „ib“ intrinsically safe	II 2G EEx ib IIC T4 II 2D T85°C ... Tmed IP67			
	Ex „d“ flameproof	II 2G EEx d [ib] IIC T6 II 2D T85°C ... Tmed IP67	Conv.: II 2G EEx d [ib] IIC T6 II 2D T85°C IP67 Prim: II 2G EEx ib IIC T4 II 2D T85°C ... Tmed IP67	II 2G EEx d [ib] IIC T6 II 2D T85°C ... Tmed IP67	Conv.: II 2G EEx d [ib] IIC T6 II 2D T85°C IP67 Prim: II 2G EEx ib IIC T4 II 2D T85°C ... Tmed IP67
	FM	XP/Class I/Div 1/BCD/T4; IS/Class I, II, III/Div 1/A-G/T4; NI/Class I/Div 2/A-D/T4 DIP/Class II, III/Div 1/E-G/T4; S/Class II, III/Div 2/FG/T4			
PROFIBUS PA FOUNDATION Fieldbus	Ex „ia“ intrinsically safe	II 2G EEx ia IIC T4 II 2D T85°C ... Tmed IP67 (FISCO-Model)			
EN10204	(DIN 50049-3.1b)	yes, Option			

Specifications Vortex Flowmeter FV4000-VT4/VR4

Flowmeter Size Selection

The flowmeter size is determined from the maximum operating flowrate Q_{Vmax} . To achieve the maximum flow range, this value should not be less than one half of the maximum flowrate for the meter size (RangeMax), but can be selected as low as 0.15 RangeMax. The start of the linear flow range is a function of the Reynolds Number (see Accuracy Specifications).

If the flowrate to be measured is specified as normal flowrate, (normal conditions: 0 °C, 1013 mbar) or as mass flowrate, the values must first be converted to actual flowrate values at operating conditions and then the appropriate meter size can be selected from the Flow Range Tables (Tbils. 1, 2, 3).

1. Convert normal density (ρ_n) --> operating density (ρ)

$$\rho = \rho_n \times \frac{1,013 + p}{1,013} \times \frac{273}{273 + T}$$

2. Convert to flowrate at operating conditions (Q_V)

a) starting with normal flowrate (Q_n) -->

$$Q_V = Q_n \frac{\rho_n}{\rho} = Q_n \frac{1,013}{1,013 + p} \times \frac{273 + T}{273}$$

b) starting with Mass flowrate (Q_m) -->

$$Q_V = \frac{Q_m}{\rho}$$

3. Dynamic viscosity (η) --> kinematic viscosity (ν)

$$\nu = \frac{\eta}{\rho}$$

- ρ = Operating density [kg/m³]
- ρ_N = Normal density [kg/m³]
- p = Operating pressure [bar]
- T = Operating temperature [°C]
- Q_V = Operating flowrate [m³/h]
- Q_n = Normal flowrate [m³/h]
- Q_m = Mass flowrate [kg/h]
- η = Dynamic viscosity [Pas]
- ν = Kinematic viscosity [m²/s]

Product Selection and Sizing Program

For the selection of suitable flowmeter designs for specific application requirements, a software program "AP-Calc" is available from ABB at no charge. (Requires WINDOWS).

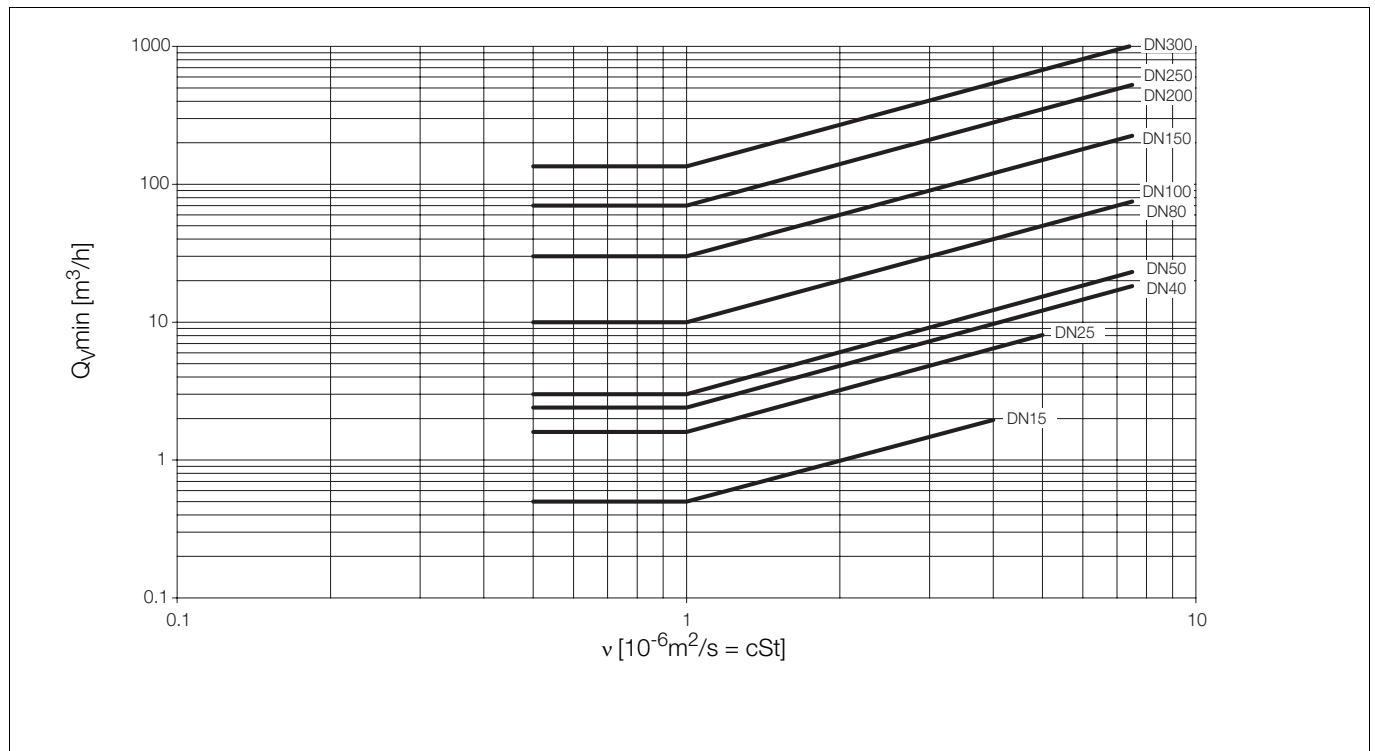

Fig. 4: Minimum Flowrate, Liquids as a Function of the Kinematic Viscosity

Flow Ranges, Liquids

Meter Size		DIN			ANSI				
DN	Inch	Q _{v,min} ¹⁾ [m ³ /h]		RangeMax [m ³ /h]	Q _{v,min} ¹⁾ [m ³ /h]		RangeMax [m ³ /h]	Frequency [Hz]	
		Std.	HT	at Q _{v,max}	Std.	HT	at Q _{v,max}		
15	1/2"	0.5	-	6	0.5	-	5.5	370	450
25	1"	1.6	3.6	18	1.6	3.6	18	240	400
40	1-1/2"	2.4	9.6	48	2.5	9.6	48	190	270
50	2"	3	14	70	3	13	66	140	176
80	3"	10	34	170	10	32	160	102	128
100	4"	10	54	270	12	43	216	72	75
150	6"	30	126	630	33	106	530	50	50
200	8"	70	220	1100	45	187	935	45	40
250	10"	70	340	1700	29	82	289	29	36
300	12"	135	480	2400	26	135	408	26	23

Tbl. 1: Flow Ranges, Liquids at 20 °C, 1013 mbar, ρ = 998 kg/m³
1) Std. 280 °C Version / HT = High temperature design (fmax = 400 °C)

Pressure Drop, Liquids

See Fig. 5 for water (20 °C, 1013 mbar, ρ = 998 kg/m³).
For other densities (ρ) the pressure drop can be calculated using the following equation:

$$\Delta p' = \frac{\rho}{998} \times \Delta p$$

Δp' = Pressure drop fluid [mbar]

Δp = Pressure drop water [mbar] (from Fig. 5)

Static Overpressure, Liquids

To avoid cavitation when metering liquids a positive static pressure (back pressure) is required downstream from the flowmeter. The required pressure can be calculated using the following equation:

$$p_2 \geq 1.3 \times p_{\text{vapor}} + 2.6 \times \Delta p'$$

p₂ = positive downstream static pressure [mbar]

p_{vapor} = vapor pressure of fluid at the operating temperature [mbar]

Δp' = pressure drop, fluid [mbar]

Example for liquids:

Find the flowmeter size for metering 55 m³/h liquid with a density of 850 kg/m³ and a kinematic viscosity of 2 cSt = (2 × 10⁻⁶ m²/s).

- Q_v = max. 55 m³/h --> DN50[2"] (per Tbl. 1): Q_{v,max} = 70 m³/h
- Flow range start, linear, at 2 cSt, (from Fig. 5): Q_{v,min} = 6 m³/h
- Press. drop (Q_v = 55 m³/h) at ρ = 850 kg/m³: Δp' = 425 mbar

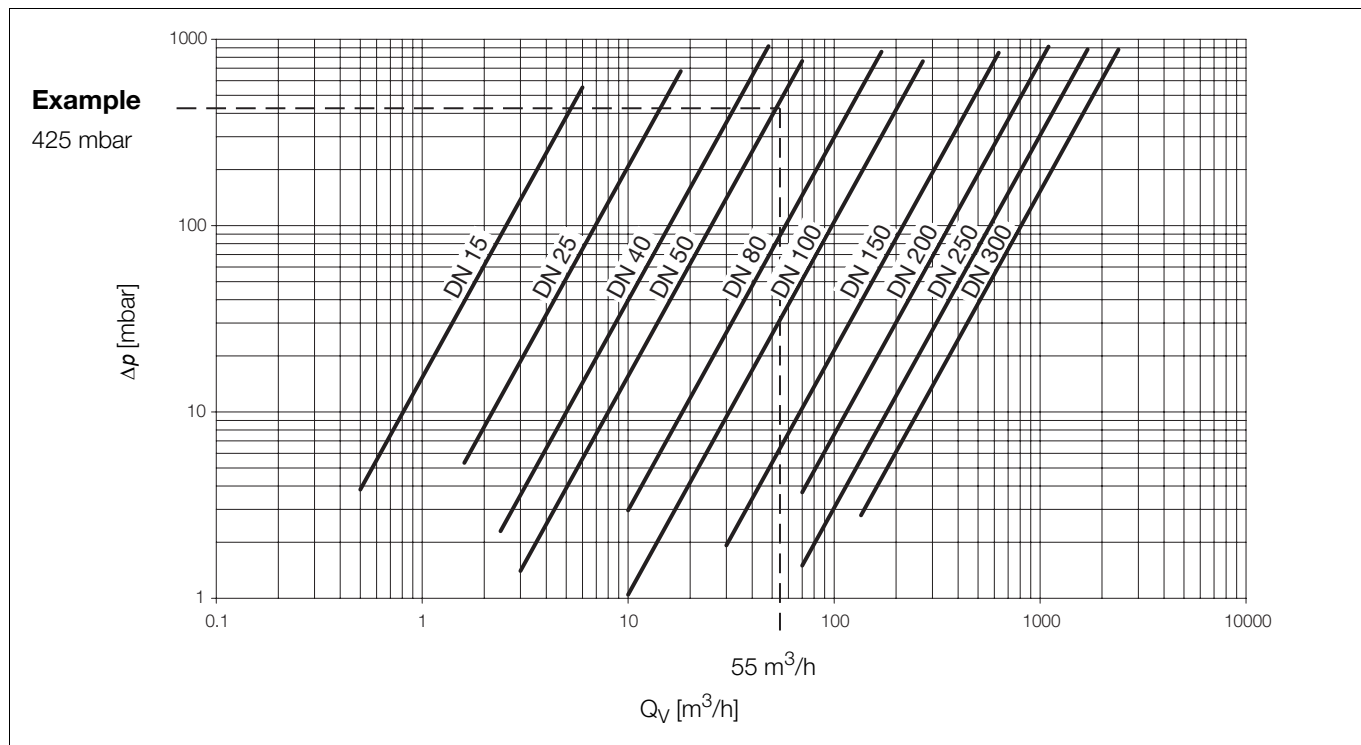

Fig. 5: Pressure Drop, Water (20 °C, 1013 mbar, ρ = 998 kg/m³), DIN-Design

Flow Ranges, Gas/Steam

Meter Size		DIN				ANSI			
DN	Inch	Q _{v,min} ⁽¹⁾ [m ³ /h]		RangeMax [m ³ /h]	Frequency [Hz] at Q _{v,max}	Q _{v,min} ⁽¹⁾ [m ³ /h]		RangeMax [m ³ /h]	Frequency [Hz] at Q _{v,max}
		Std.	HT			Std.	HT		
15	1/2"	4	-	24	1520	5	-	22	1980
25	1"	15	30	150	2040	12	16	82	1850
40	1-1/2"	30	78	390	1550	21	68	340	1370
50	2"	40	100	500	1030	43	90	450	1180
80	3"	100	240	1200	700	78	190	950	780
100	4"	150	380	1900	500	120	360	1800	635
150	6"	300	900	4500	360	260	810	4050	405
200	8"	430	1600	8000	285	420	1360	6800	240
250	10"	810	2800	14000	260	820	2400	12000	225
300	12"	1410	4000	20000	217	1300	3400	17000	195

Tbl. 2: Flow Ranges, Gases at ρ = 1.2 kg/m³

1) Std. 280 °C Version / HT = High temperature design (fmax = 400 °C)

Example for Gases:

Find the flowmeter size for metering 2540 m³/h (q_n) CO₂-Gas;
 Temp. = 85 °C, Press. = 5 bar a.
 For details see Page 4 "Flowmeter Size Selection"

ρ_n = 1.97 kg/m³ (CO₂)

- Convert ρ_n --> ρ : ρ = 7.4 kg/m³
- Convert m³/h (q_n) --> m³/h (q_v): Q_v = 676 m³/h (q_v)
 --> Selection : DN 80[3"] (Q_{v,max} = 1200 m³/h (q_v))
- Pressure drop at ρ = 7.4 kg/m³: Δp' = 100 mbar
- Flow range start at ρ = 7.4 kg/m³ (from Fig. 7):
 Q_{v,min} = 45m³/h,
 Convert m³/h (q_v) --> m³/h (q_n): Q_{v,min} = 169 m³/h (q_n)

Pressure Drop, Gas/Steam

See Fig. 8 for air (at 20 °C, 1013 mbar, ρ = 1.2 kg/m³)
 For other fluid densities the pressure drop can be calculated using the following equation:

$$\Delta p' = \frac{\rho}{1,2} \times \Delta p$$

Δp' = Pressure drop fluid [mbar]

Δp = Pressure drop air [mbar] (from Fig. 8)

Normal Densities of Various Gases:

Gas	Normal Density [kg/m ³]
Acetylene	1.172
Air	1.290
Ammonia	0.771
Argon	1.780
Butane	2.700
Carbon dioxide	1.970
Carbon monoxide	1.250
Ethan	1.350
Ethylene	1.260
Hydrogen	0.0899
Methane	0.717
Natural gas	0.828
Neon	0.890
Nitrogen	1.250
Oxygen	1.430
Propane	2.020
Propylene	1.915

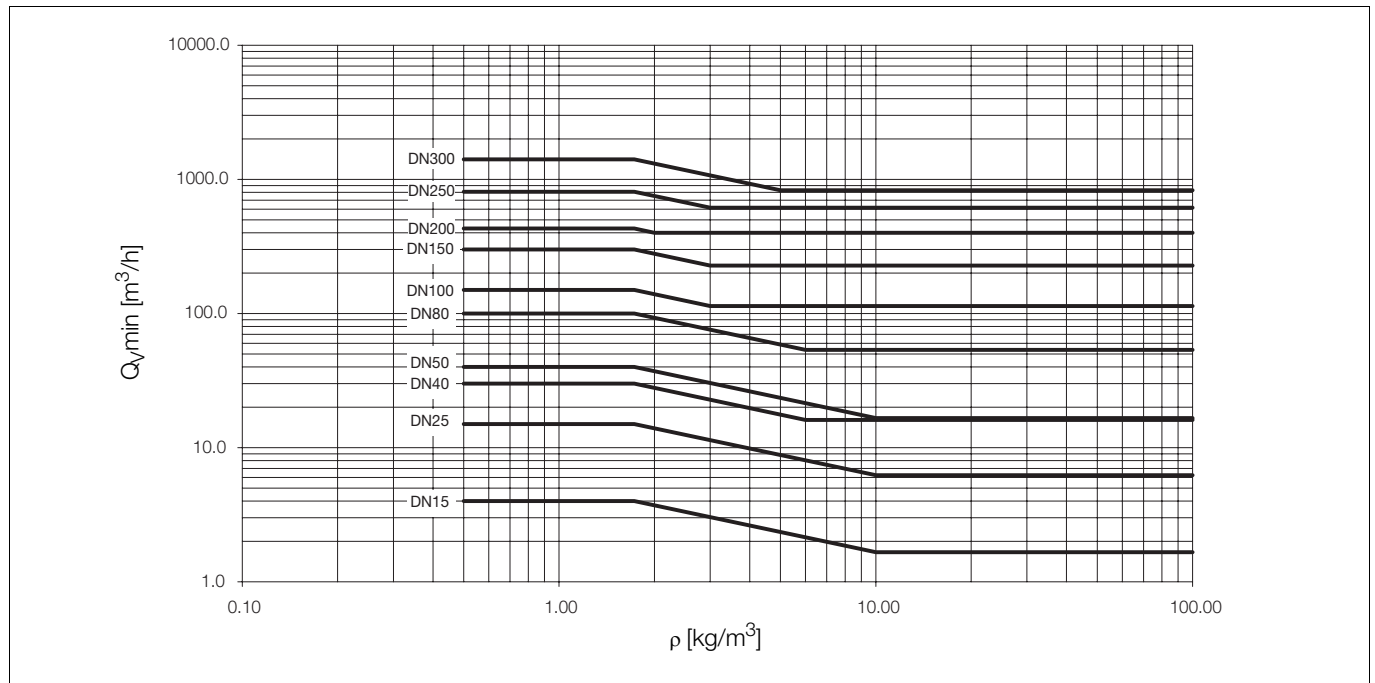

Fig. 6: Minimum Flowrates, Gas/Steam as a Function of the Fluid Density, DIN-Design (280 °C)

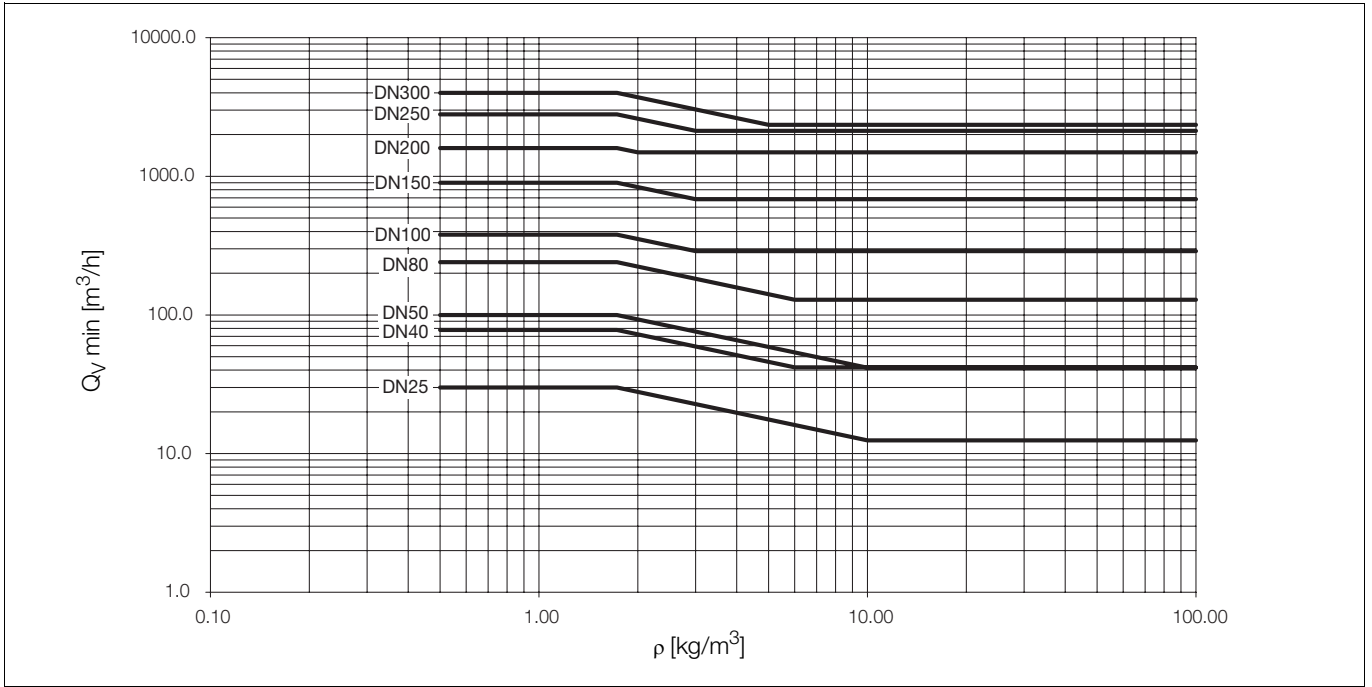

Fig. 7: Minimum Flowrates, Gas/Steam as a Function of the Fluid Density, DIN-Design (HT)

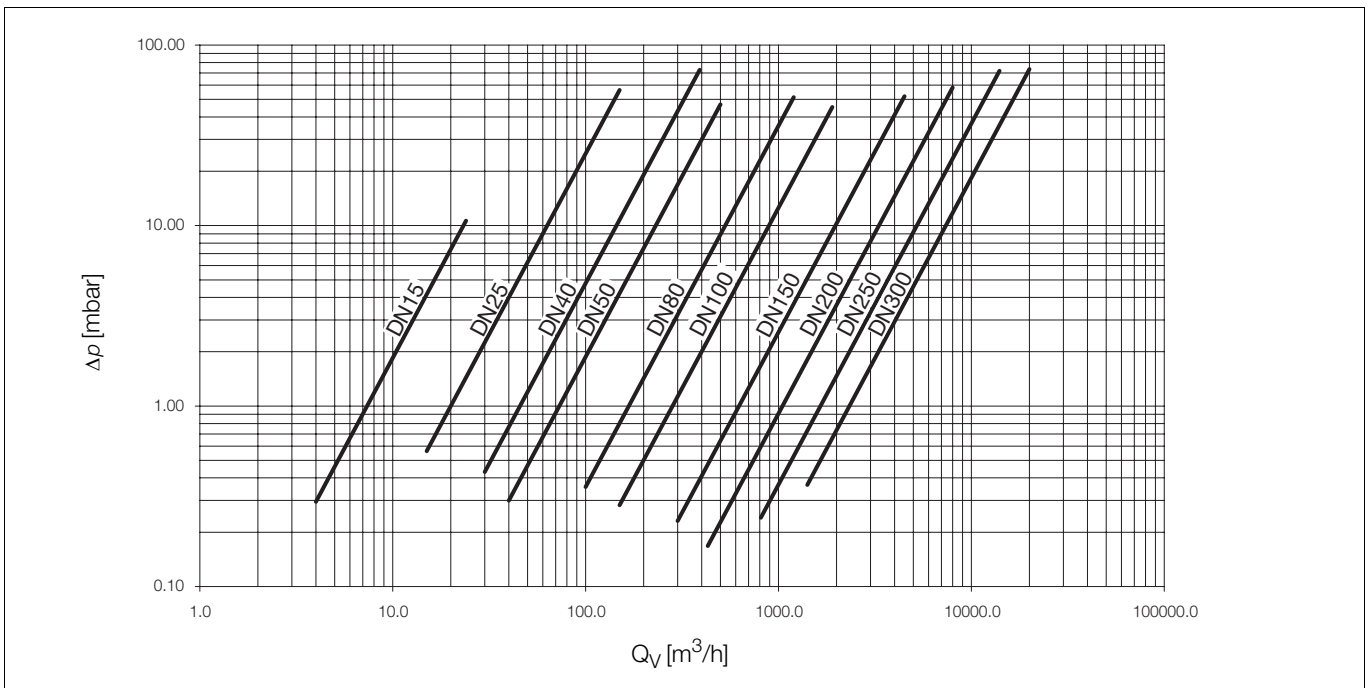

Fig. 8: Pressure Drop, Air (20 °C, 1013 mbar, = 1.2 kg/m^3), DIN-Design

Flowrates Saturated Steam [kg/h]

Example for Saturated Steam:

Find the flow range for DN 50 [2"] at 7 bar (a).

--> from Tbl. 3: DN 50[2"]: 101 - 1835 kg/h

Additional information:

Sat. steam temp.= 165 °C

Sat. steam dens.= 3.67 kg/m³

p[bar a]		1	1.5	2	3	4	5	6	7	8	9	10	12	15	25	30	35	40	45	50	
Meter Size Inch	DN																				
1/2"	15	min	2	3	5	7	8	9	9	10	11	11	12	13	14	21	25	29	33	38	42
		max	14	21	27	40	52	64	76	88	100	112	124	147	182	300	360	420	480	544	609
1"	25	min	9	13	17	25	29	32	35	38	40	43	45	49	54	78	94	109	125	141	158
		max	89	129	170	248	324	401	476	551	624	699	773	849	920	1140	1875	2250	2625	3000	3401
1-1/2"	40	min	18	26	34	50	58	64	70	76	80	85	89	99	122	201	241	282	322	365	408
		max	230	335	441	644	842	1041	1236	1431	1622	1817	2009	2391	2964	4875	5850	6825	7800	8841	9890
2"	50	min	24	34	45	66	77	86	94	101	107	114	119	130	145	208	249	291	333	377	422
		max	295	430	565	825	1080	1335	1585	1835	2080	2330	2575	3065	3800	6250	7500	8750	10000	11335	12680
3"	80	min	59	86	113	165	193	215	234	252	268	284	298	329	408	671	805	939	1073	1217	1361
		max	708	1032	1356	1980	2592	3204	3804	4404	4992	5592	6180	6756	7356	9120	15000	18000	21000	24000	27204
4"	100	min	89	129	170	248	290	322	361	418	474	531	586	698	865	1423	1708	1992	2277	2581	2887
		max	1121	1634	2147	3135	4104	5073	6023	6973	7904	8854	9785	11647	14440	23750	28500	33250	38000	43073	48184
6"	150	min	177	258	339	495	580	644	722	836	947	1061	1173	1396	1730	2846	3415	3984	4554	5162	5774
		max	2655	3870	5085	7425	9720	12015	14265	16515	18720	20970	23175	27585	34200	56250	67500	78750	90000	102015	114120
8"	200	min	254	370	486	710	863	1067	1267	1467	1663	1863	2058	2450	3038	4996	5995	6995	7994	9061	10136
		max	4720	6880	9040	13200	17280	21360	25360	29360	33280	37280	41200	49040	60800	100000	120000	140000	160000	181360	202880
10"	250	min	478	697	915	1337	1565	1740	1949	2256	2557	2865	3166	3768	4672	7684	9221	10758	12295	13936	15590
		max	8260	12040	15820	23100	30240	37380	44380	51380	58240	65240	72100	85820	106400	175000	210000	245000	280000	317380	355040
12"	300	min	832	1213	1593	2327	2724	3092	3300	3551	3780	4001	4269	5081	6300	10361	12434	14506	16578	18791	21021
		max	11800	17200	22600	33000	43200	53400	63400	73400	83200	93200	103000	122600	152000	250000	300000	350000	400000	453400	507200
Density ρ_{sat} [kg/m ³]			0.59	0.86	1.13	1.65	2.16	2.67	3.17	3.67	4.16	4.66	5.15	6.13	7.60	12.50	15.00	17.50	20.00	22.67	25.36
Temp. T _{sat} [°C]			99.6	111.4	120	133	144	152	159	165	170	175	180	188	198	224	234	242	250	258	264

Tbl. 3: Saturated Steam Flow Ranges, DIN-Design

Flowrate Measurement Accuracy and Reproducibility

Accuracy (incl. converter),

linear flow range (Re min (see Tbl. 4)

Gases/Steam: $\leq \pm 1$ % of rate at reference conditions

Liquids: $\leq \pm 0.75$ % of rate at reference conditions.

Reproducibility

DN	Inch	Reproducibility
15	1/2"	0.3 %
25 - 150	1" - 6"	0.2 %
200 - 300	8" - 12"	0.25 %

Reference Conditions for Flow Metering

Flow range setting:	0.5*RangeMax....1*RangeMax
Ambient temperature:	20 °C +/- 2K
Humidity:	65 % rel. humidity +/- 5 %
Barometric press.:	86 kPa 106 kPa
Supply power:	24 VDC
Signal cable length:	10 m (only FV4000)
Current output load:	250 Ohm (only for 4-20mA)
Calibration fluid:	Air: 20 °C, atmospheric press. Water: approx. 20 °C, 2 bar
Calibration loop internal diameter:	Same as meter inside diameter
Unobstructed str. upstream section:	15 x D
Downstream section:	5 x D
Pressure tap:	3-5 x D downstream from shedder
Temperature measurement:	2-3 x D downstream from pressure tap.

Overload:

Gases:

15 % over maximum flowrate

Liquids:

15 % over maximum flowrate

Note: Cavitation may not exist

Temperature Measurement Accuracy and Reproducibility

Accuracy (incl. converter)

± 2 °C

Allowable Pipeline Vibrations

Guide Values:

The acceleration values listed below are to be used a guidelines.

Since the actual value is a function of the flowmeter size, the flowrate within the flow range and the frequency of the vibrations, these acceleration values can only be used conditionally.

Liquids: max. 1.0 g 0-130 Hz

Gases/Steam: max. 0.3 g 0-130 Hz

Process Connections

Flanges: DIN PN 10 to 40, Option to PN 160
ASME Class 150/300, Option to CI 900
Flat gasket (Graphite) maximum
PN 64/ASME Class 300

Wafer design: DIN PN 10 to 40, Option to PN 100
ASME Class 150/300, Option to CI 600
Flat gasket (Graphite) maximum
PN 64/ASME Class 300

Meter Size		Re min * 1000	
DN	Inch	DIN	ANSI
15	1/2"	10	11
25	1"	20	23
40	1-1/2"	20	23
50	2"	20	22
80	3"	43	48
100	4"	33	44
150	6"	67	80
200	8"	120	128
250	10"	96	115
300	12"	155	157

Tbl. 4: Minimum Reynolds No. Re_{min} for Linear Flow Range Start

Materials:

Flowmeter Primary

Process Conn.	Meter Housing	Materials	
		Flanges	Shedder
Flanged DN15, DN200 - DN300 [1/2", 8"-12"]	Std. 1.4571/316Ti opt. Hast.-C	Std. 1.4571/316Ti opt. Hast.-C	Std. 1.4571/316Ti opt. Hast.-C
Flanged * DN25 -DN150 1" - 6"	Std. 1.4571/316Ti opt. Hast.-C	Std. 1.4571/316Ti opt. Hast.-C	Std. 1.4571/316Ti opt. Hast.-C
Wafer design	Std. 1.4571/316Ti opt. Hast.-C	-	Std. 1.4571/316Ti opt. Hast.-C

Sensor: 1.4571[316Ti] opt. Hast.-C

Sensor Gasket

- Kalrez (3018) O-Ring: 0 °C to 280 °C
- Kalrez (6375) O-Ring: -20 °C to 275 °C
- Viton O-Ring: -55 °C to 230 °C
- PTFE O-Ring: -55 °C to 200 °C
- Graphite: -55 °C to 280 °C
- Graphite-Special: -55 °C to 400 °C (High temperature)
- Other materials upon request.

Housing, Electronic Module

Die cast Alum., painted

Weight:

see Dimensions

Fluid Temperature (Standard and Ex):



Attention!

Observe the specifications in the Chapter, Explosion Protection starting on Page 32

- 55 °C to +280 °C (Standard)
- 55 °C to +400 °C (HT-Design)
- Allowable temperature of gaskets must be considered

Ambient Conditions:

Climate Resistance per DIN 40040)

Ex-Prot. Model	Allow. Ambient Temperature Range	Climate Class	
		Standard	Climate Resistance
None / VT40 & VR40	-20 °C ... +70 °C	Z ¹ SG ²	Z ¹ SA
	-55 °C ... +70 °C	FSG ²	FSA
Ex ib / VT41 & VR41	-20 °C ... +70 °C	Z ¹ SG ²	Z ¹ SA
	-55 °C ... +70 °C	FSG ²	FSA
Ex ia / VT4A & VR4A	-20 °C ... +60 °C	Z ¹ UG ²	Z ¹ UA
	-40 °C ... +60 °C	GUG ²	GUA
Ex d / VT42 & VR42	-20 °C ... +60 °C	Z ¹ UG ²	Z ¹ UA
	-40 °C ... +60 °C	GUG ²	GUA
FM VT43 u. VR43	-20 °C ... +70 °C	Z ¹ SG ²	Z ¹ SA

1) Z = Lower ambient temperature limit = -20 °C
2) G = Relative humidity max. 85 %, yearly average ≤ 65 %

Allowable Process Pressures as a Function of the Fluid Temperature

Process Connections DIN-Flanges

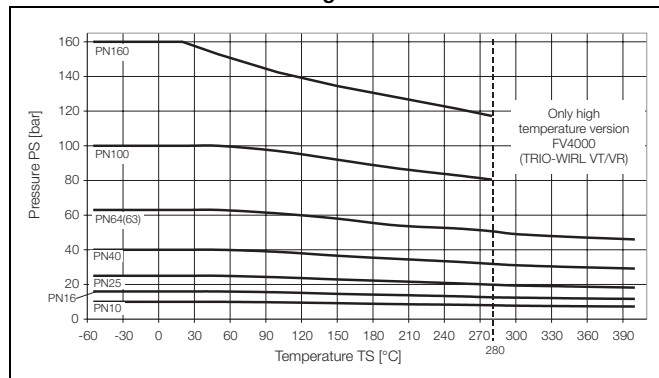

Process Connections ASME-Flanges

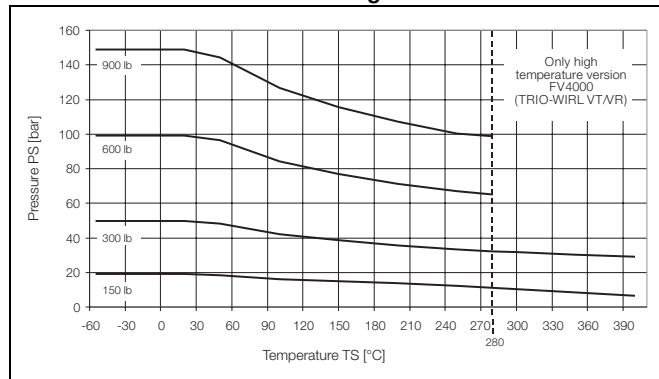

Process Connections DIN-Wafer Design

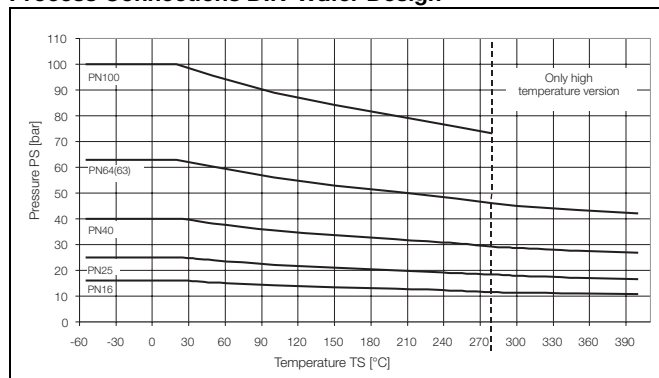

Process Connections ASME-Wafer Design

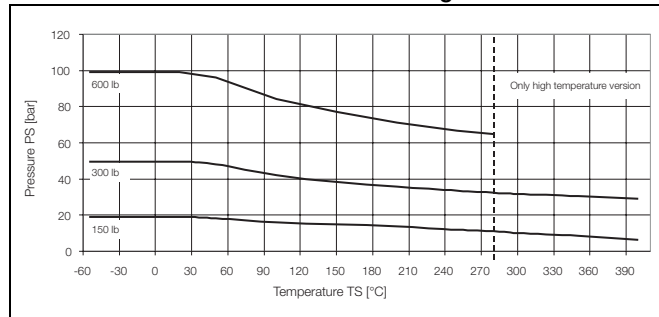

Installation, Vortex Flowmeter FV4000-VT4/VR4

Fluid /Ambient Temperatures:

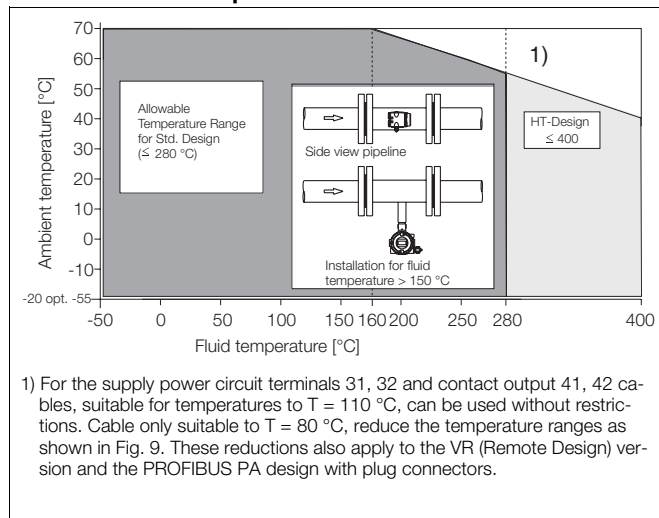

Fig. 9: Relationship. Fluid Temperature/Ambient Temperature



Information!

For temperatures $< 0\text{ °C}$ and $> 55\text{ °C}$ the readability of the display may be compromised. The functionality and the outputs of the instrument are unaffected. Ambient temperatures $< -20\text{ °C}$ see Ordering Information.

Converter specifications begin on Page 28

Installation Information

In- and Outlet Sections

In order to guarantee complete functionality, the flow profile at the inlet should be undisturbed.

A inlet straight section length 15 times the nominal diameter should be provided.

After elbows the straight length should be at least 25 times, for double elbows at least 50 times the nominal diameter.

At the outlet, a straight length of 5 times the nominal diameter should be maintained (Fig. 10).

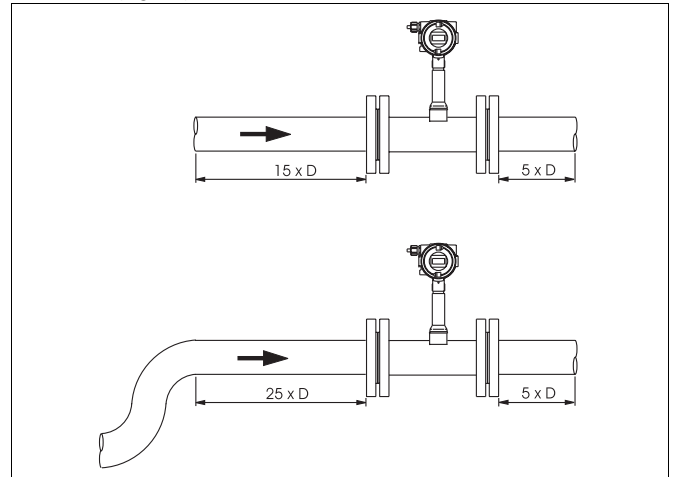

Fig. 10:

Regulating and control devices should be installed at least $5 \times D$ downstream (Fig. 11).

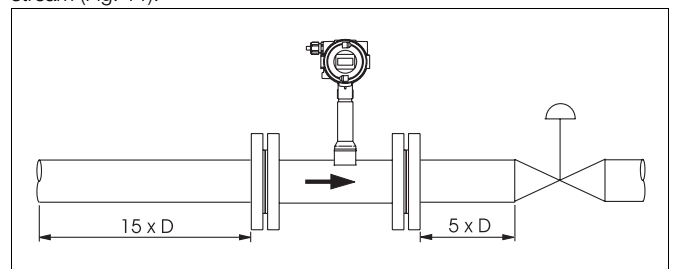

Fig. 11: Installation of Control Devices

If the system utilizes a piston pump or compressor to produce the flow, (pressures for liquids $> 10\text{ bar}$) water hammer may occur when the valve is closed. In this case it is essential that the valves be installed upstream of the flowmeter. Otherwise a suitable dampening device (e.g. a tank when using a compressor) should be provided.

Supplementary Installation Information

- For liquids assure that the flowmeter primary is always completely filled with fluid.
- In horizontal installations with fluid temperatures > 150 °C see Fig. 12 for installation requirements.
- If gas bubbles may be present, a gas separator should be provided.
- For installation in long pipelines susceptible to vibrations, they should be damped up- and downstream of the instrument.

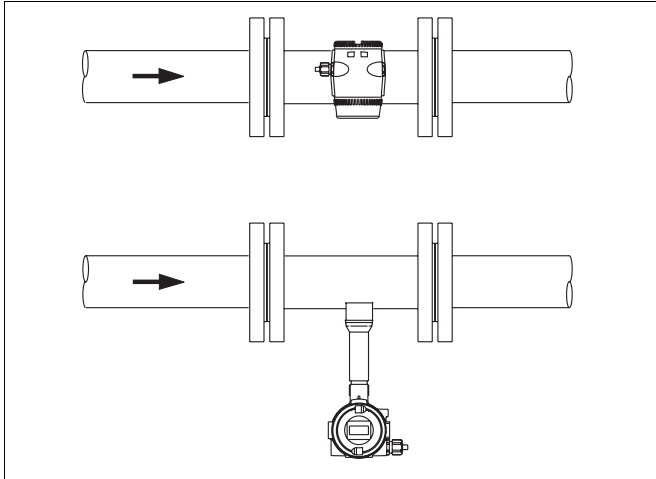

Fig. 12: Installation for High Fluid Temperatures

Pressure and temperature measurements should be made downstream from the flowmeter (Fig. 13). To use the internal temperature measurement see the information in the converter section.

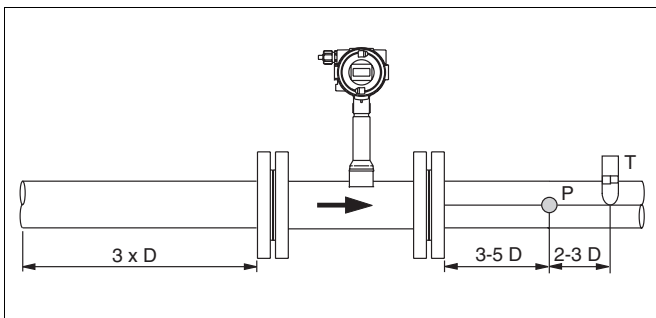

Fig. 13: Pressure and Temperature Measurement Locations

Centering the Wafer Design Flowmeters

The wafer design flowmeter is centered using the outside diameter of the flowmeter primary body and by its mounting bolts. In addition, as a function of the pressure rating, centering sleeves for the bolts, a centering ring (to DN 80 [3"] or segments may be ordered as accessories (see Fig. 14).

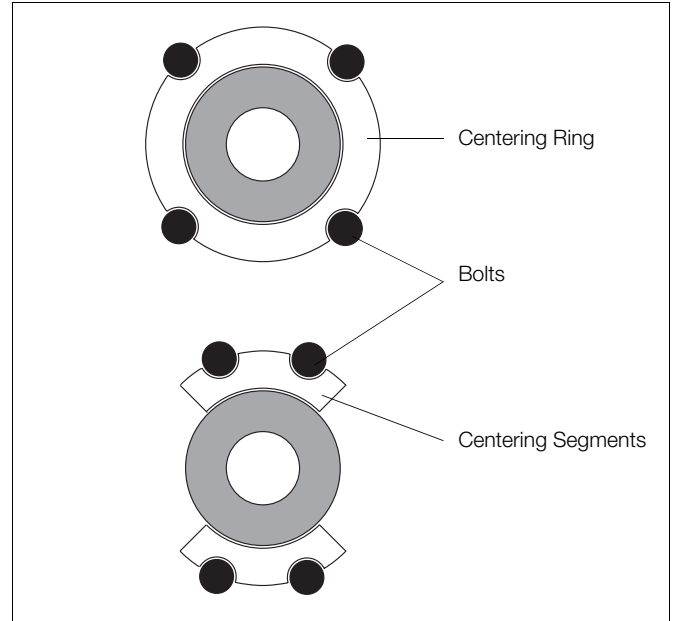

Fig. 14: Centering the Wafer Design using Centering Rings or Segments

Dimensions FV4000-VT4/VR4 (TRIO-WIRL V), Wafer Design

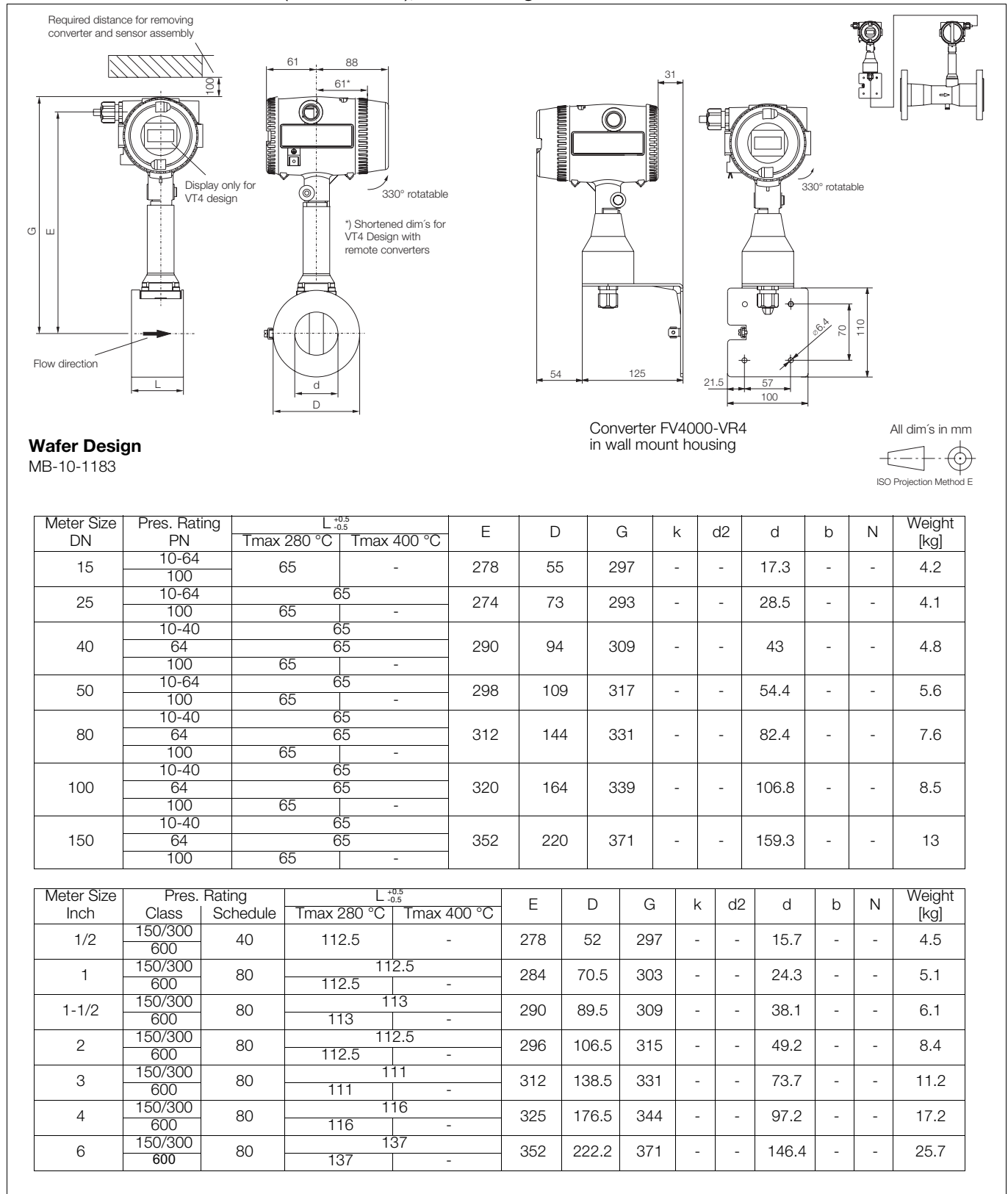

Fig. 15: Dimensions FV4000-VT4/VR4, DIN & ANSI

Dimensions FV4000-VT4/VR4 (TRIO-WIRL V), Flanged Design, DIN

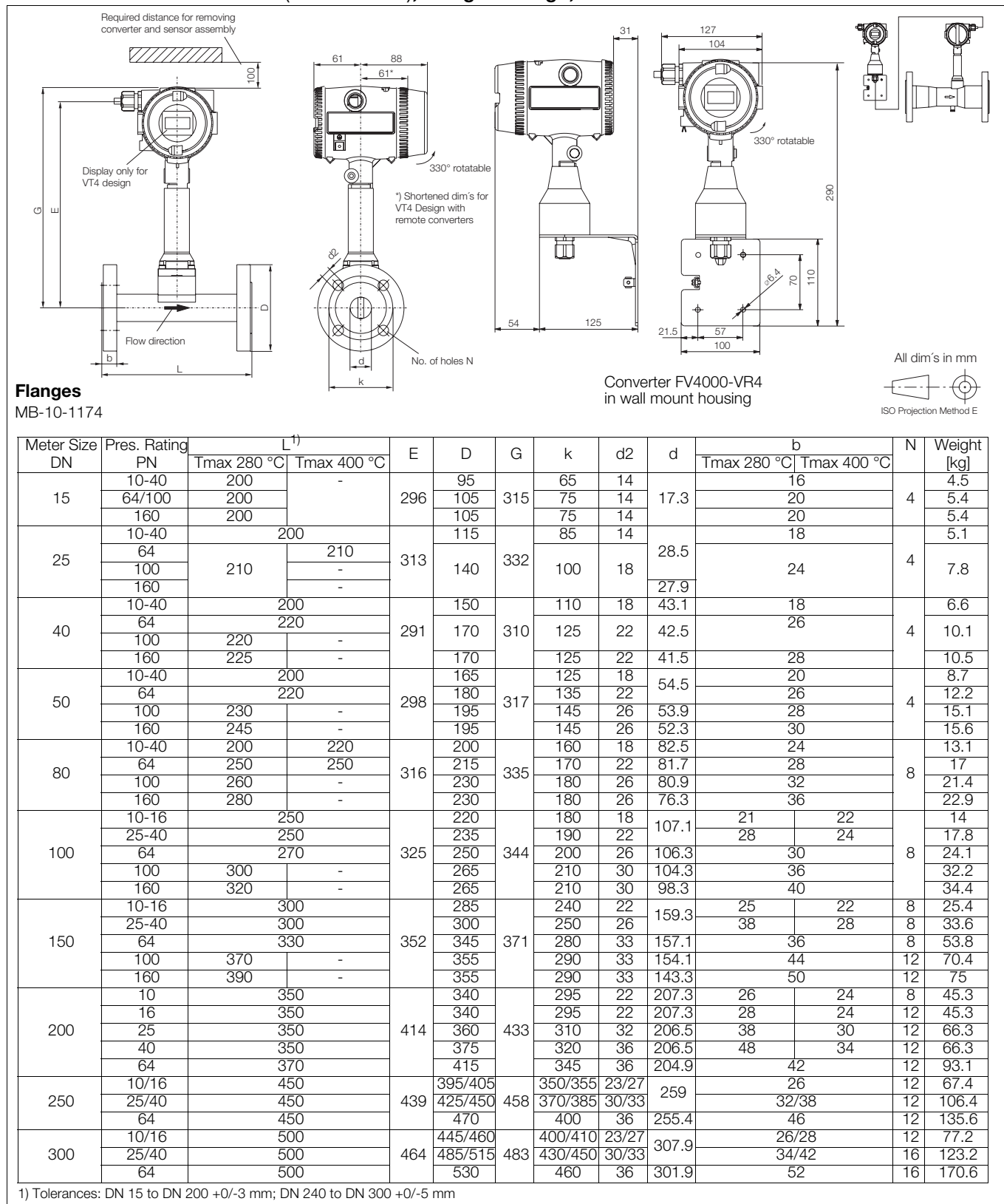

Fig. 16: Dimensions FV4000-VT4/VR4, Flanged Design, DIN

Dimensions FV4000-VT4/VR4 (TRIO-WIRL V), Flanged Design, ASME

Meter Size	Pres. Rating		L ¹⁾		E	D	G	k	d2	d	b	N	Weight [kg]
	Class	Schedule	Tmax 280°C	Tmax 400°C									
1/2"	150	40	200	-	296	88.9	315	60.5	15.9	15.7	11.2	4	5.0
	300	40	200					95.2	15.9		14.2		5.1
	600	40	200					95.3	15.9		20.6		5.2
	900	40	200					120.6	22.3		28.8		7.9
1"	150	80	200	205	313	108	332	79.4	15.9	24.3	14.2	4	5.7
	300	80	200	220		124		19	17.5		6.7		
	600	80	220	-		124		19	23.9		7.3		
	900	80	240	-		149.3		25.4	34.8		11.2		
1-1/2"	150	80	200	220	291	127	310	98.4	15.9	38.1	17.5	4	8.5
	300	80	200	230		155.6		22.6	20.6		10.9		
	600	80	235	-		155.6		22.6	28.8		12.1		
	900	80	260	-		177.8		28.4	38.2		17.0		
2"	150	80	200	220	298	152.4	317	120.6	19	49.2	19.1	4	10.1
	300	80	200	235		165		19	22.4		11.7		
	600	80	240	-		165		19	31.8		13.6		
	900	80	300	-		215.9		25.4	44.5		26.5		
3"	150	80	200	240	316	190.5	335	152.4	19	73.7	23.9	4	17.6
	300	80	200	260		209.5		22.2	28.4		21.7		
	600	80	265	-		209.5		22.2	38.2		25.8		
	900	80	305	-		241.3		25.4	44.5		35.0		
4"	150	80	250	260	325	228.6	344	190.5	19	97.2	23.9	8	20.1
	300	80	250	280		254		22.2	31.8		28.8		
	600	80	315	-		273.1		25.4	44.5		41.4		
	900	80	340	-		292.1		31.7	50.8		51.4		
6"	150	80	300	310	352	279.4	371	241.3	22.2	146.4	25.4	8	32.8
	300	80	300	330		317.5		22.2	36.6		49.8		
	600	80	365	-		355.6		28.4	54.2		81.6		
	900	80	410	-		381		31.7	62		106.8		
8"	150	80	350		414	343	433	298.4	22.2	194	28.4	8	
	300	80	350	370		381		25.4	41.1				
	600	80	415	-		419.1		31.8	62				
	900	80	470	-		469.9		38.1	69.9				
10"	150	40	450		439	406.4	458	362	25.4	253	30.2	12	
	300	40	450			444.5		28.4	47.7		16		
	600	80	470	-		508		35.1	69.9		16		
12"	150	40	500		464	482.6	483	431.8	25.4	303.9	31.8	12	
	300	40	500			520.7		31.7	50.8		16		
	600	80	500	-		558.8		35.1	72.9		20		

1) Tolerances: 1/2" to 8" +0/-3 mm; 10" to 12": +0/-5 mm

Fig. 17: Dimensions FV4000-VT4/VR4, Flanges, ASME

Ordering Information Vortex Flowmeter FV4000-VT4/VR4 (TRIO-WIRL V)

Ordering Number		V																		
Instrument Design																				
Compact		T																		
Remote		R																		
Series			4																	
Ex-Approvals (function of communication option)																				
None																				
CENELEC „Intrinsic Safety“ HART ¹⁾																				
CENELEC „Pressure Tight“ HART ²⁾																				
FM-Approval (Class 1 / Div. 1) HART																				
CSA-Approval HART ³⁾																				
CENELEC „Intrinsic Safety“ PA/FF ³⁾																				
Others																				
Process Connections																				
Flanges																				
Flanges with groove (DIN 2512)																				
Wafer design (<DN 200[8"]) max PN 100/CL 600																				
Others																				
Fluid																				
Liquids																				
Gas																				
Steam																				
Oxygen ⁴⁾																				
Materials																				
Housing	Shedder	Sensor																		
SS 1.4571[316Ti]	SS 1.4571[316Ti]	SS 1.4571[316Ti]																		
SS 1.4571[316Ti]	Hastelloy C	SS 1.4571[316Ti]																		
Hastelloy C	Hastelloy C	Hastelloy C																		
SS 1.4571[316Ti]	Hastelloy C	Hastelloy C																		
Others																				
Meter Sizes		Standard Pressure Rating																		
DN 15 / 1/2"	PN 40																			
DN 25 / 1"	PN 40																			
DN 40 / 1-1/2"	PN 40																			
DN 50 / 2"	PN 40																			
DN 80 / 3"	PN 40																			
DN 100 / 4"	PN 16																			
DN 150 / 6"	PN 16																			
DN 200 / 8"	PN 16																			
DN 250 / 10"	PN 16																			
DN 300 / 12"	PN 16																			
Pressure Rating																				
DIN PN 10																				
DIN PN 16																				
DIN PN 25																				
DIN PN 40																				
DIN PN 64																				
DIN PN 100 ⁵⁾ 6)																				
DIN PN 160 ⁵⁾ 6)	(only flanged designs)																			
ASME CL 150																				
ASME CL 300																				
ASME CL 600 ⁵⁾ 6)																				
ASME CL 900 ⁵⁾ 6)	(only flanged designs)																			
Others																				

1) Design also for use in Ex-Zone 2 (II 3G EEx nA [L] IIC T4) and for use in areas with combustible dust (II 2D T85 °C ... Tmed IP67) approved.
 2) Design also for use in Ex-Zone 2 (II 3G EEx nA [L] IIC T4) and Zone 1 (II 2G EEx ib IIC T4) and for use in areas with combustible dust (II 2D T85 °C ... Tmed IP67) approved.
 3) Also for use in areas with combustible dust (II 2D T85 °C ... Tmed IP67) approved.
 4) Flowmeter primary cleaned and marked for Oxygen service.
 5) For meter sizes > DN 25 [1"] always with Matl.-Traceability EN10204-3.1C for Applicability Range EC/23/97 (Pressure Equipment Directive)
 6) Not in design with FM or CSA Approvals

Accessories:

When P/T compensation is required, see Specifications Sensycal Flow Computer .

Wafer Design Accessories (Option)

Meter size / pressure rating dependent. Included in the optional standard accessories (these include the bolts, nuts, lock washers) and when required, the centering elements.

Gaskets are not included in the accessories.

Material: Stn. stl. No.: 1.4571[316Ti]

Meter Size	Pressure Rating	Ordering Number
DN 15	PN 10-40	D614L384U01
	PN 64-100	D614L384U15
DN 25	PN 10-40	D614L384U01
	PN 64-100	D614L384U11
DN 40	PN 10-40	D614L384U02
	PN 64	
DN 50	PN 10-40	D614L384U03
	PN 64	D614L384U13
DN 80	PN 10-40	D614L384U04
	PN 64	D614L384U12
DN 100	PN 10-16	D614L384U05
	PN 25-40	D614L384U06
	PN 64	D614L384U16
DN 150	PN 10-16	D614L384U07
	PN 25-40	D614L384U08
	PN 64	D614L384U17

Meter Size	Pressure Rating	Ordering Number
1/2"	CL 150	D614L498U01
	CL 300	
	CL 600	
1"	CL 150	D614L414U01
	CL 300	D614L414U02
	CL 600	
1-1/2"	CL 150	D614L414U03
	CL 300	D614L414U04
	CL 600	
2"	CL 150	D614L414U05
	CL 300	D614L414U06
	CL 600	D614L414U14
3"	CL 150	D614L414U07
	CL 300	D614L414U08
	CL 600	
4"	CL 150	D614L414U09
	CL 300	D614L414U10
	CL 600	D614L414U13
6"	CL 150	D614L414U11
	CL 300	D614L414U12
	CL 600	D614L414U15

Specifications Swirl Flowmeters FS4000-ST4/SR4 (TRIO-WIRL S)

Meter Size Selection

The flowmeter size is determined from the maximum operating flow-rate Q_{Vmax} . To achieve the maximum flow range, this value should not be less than one half of the maximum flowrate for the meter size (RangeMax), but can be selected as low as approx. 0.15 RangeMax. The start of the linear flow range is a function of the Reynolds Number (see Accuracy Specifications Page 22). If the flowrate to be measured is specified as normal flowrate, (normal conditions: 0 °C, 1013 mbar) or as mass flowrate, the values must first be converted to actual flow-rate values at operating conditions and then the appropriate meter size selected from the Flow Range Tables (TbIs. 5, 6, 7).

1. Convert normal density (ρ_n) --> operating density (ρ)

$$\rho = \rho_n \times \frac{1,013 + p}{1,013} \times \frac{273}{273 + T}$$

2. Convert to flowrate at operating conditions (Q_V)

a) starting with normal flowrate (Q_n) -->

$$Q_V = Q_n \frac{\rho_n}{\rho} = Q_n \frac{1,013}{1,013 + p} \times \frac{273 + T}{273}$$

b) starting with mass flowrate (Q_m) -->

$$Q_V = \frac{Q_m}{\rho}$$

3. Dynamic viscosity (η) --> kinematic viscosity (ν)

$$\nu = \frac{\eta}{\rho}$$

ρ = Operating density [kg/m³]

ρ_n = Normal density [kg/m³]

p = Operating pressure [bar]

T = Operating temperature [°C]

Q_V = Operating flowrate [m³/h]

Q_n = Normal flowrate [m³/h]

Q_m = Mass flowrate [kg/h]

η = Dynamic viscosity [Pas]

ν = Kinematic viscosity [m²/s]

Product Selection and Sizing Program

For the selection of suitable flowmeter designs for specific application requirements, a software program "AP-Calc" is available from ABB at no charge. (Requires WINDOWS).

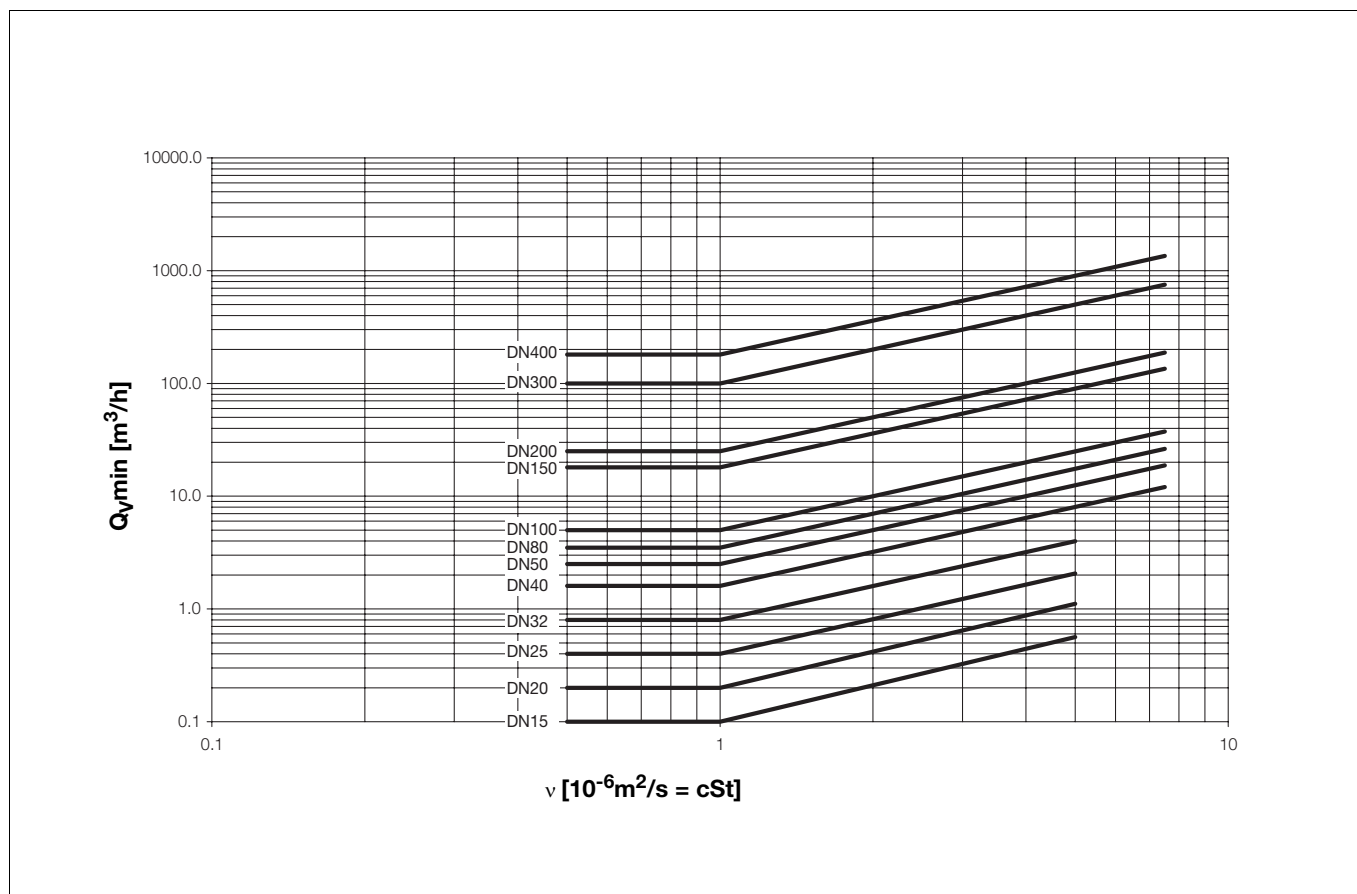

Fig. 18: Minimum Flowrates, for Liquids as a Function of the Kinematic Viscosity

Flowrates, Liquids

Meter Size DN	Inch	Q _v min [m ³ /h]	RangeMax [m ³ /h]	Frequency [Hz] at RangeMax	Re min
15	½"	0.1	1.6	185	2100
20	¾"	0.2	2	100	3500
25	1"	0.4	6	135	5200
32	1-1/4"	0.8	10	107	7600
40	1-1/2"	1.6	16	110	13500
50	2"	2.5	25	90	17300
80	3"	3.5	100	78	15000
100	4"	5	150	77	17500
150	6"	18	370	50	43000
200	8"	25	500	30	44000
300	12"	100	1000	16	115000
400	16"	180	1800	13	160000

Tbl. 5: Flowrates, Liquids at 20 °C, 1013mbar,
 v N 1 cSt, ρ N 998 kg/m³

Pressure Drop, Liquids

See Fig. 19 for water (20 °C, 1013 mbar, ρ = 998 kg/m³).
 For other fluid densities (ρ) the pressure drop can be calculated using
 the following equation:

$$\Delta p' = \frac{\rho}{998} \times \Delta p$$

Δp' = Pressure drop fluid [mbar]

Δp = Pressure drop water [mbar] (from Fig. 19)

Static Overpressure, Liquids

To avoid cavitation when metering liquids, a positive static pressure (back pressure) is required downstream from the flowmeter. The required pressure can be calculated from the following equation:

$$p_2 \geq 1.3 \times p_{\text{vapor}} + 2.6 \times \Delta p'$$

p₂ = positive downstream static pressure [mbar]

p_{vapor} = liquid vapor pressure at the operating temperature [mbar]

Δp' = pressure drop fluid [mbar]

Example for liquids:

Find the flowmeter size for metering 55 m³/h liquid with a density of 850 kg/m³ and a kinematic viscosity of 3cSt = (3 x 10⁻⁶ m²/s).

1. Q_v = max. 55 m³/h --> DN 80 [3"] (per Tbl. 5): RangeMax = 100 m³/h
2. Flow range start, linear, at 3 cSt, (from Fig.18): Q_v min = 10.5 m³/h
3. Pressure drop (Q_v = 55 m³/h) for = 850 kg/m³: = 259 mbar

Information for liquids with higher viscosities

The Swirl Flowmeter FS4000-ST4/SR4 can also be used to meter the flowrate of liquids with higher viscosities (for limits see Page 3). To maintain the accuracy a field calibration is required if the viscosity is 7.5 mPaS or higher.

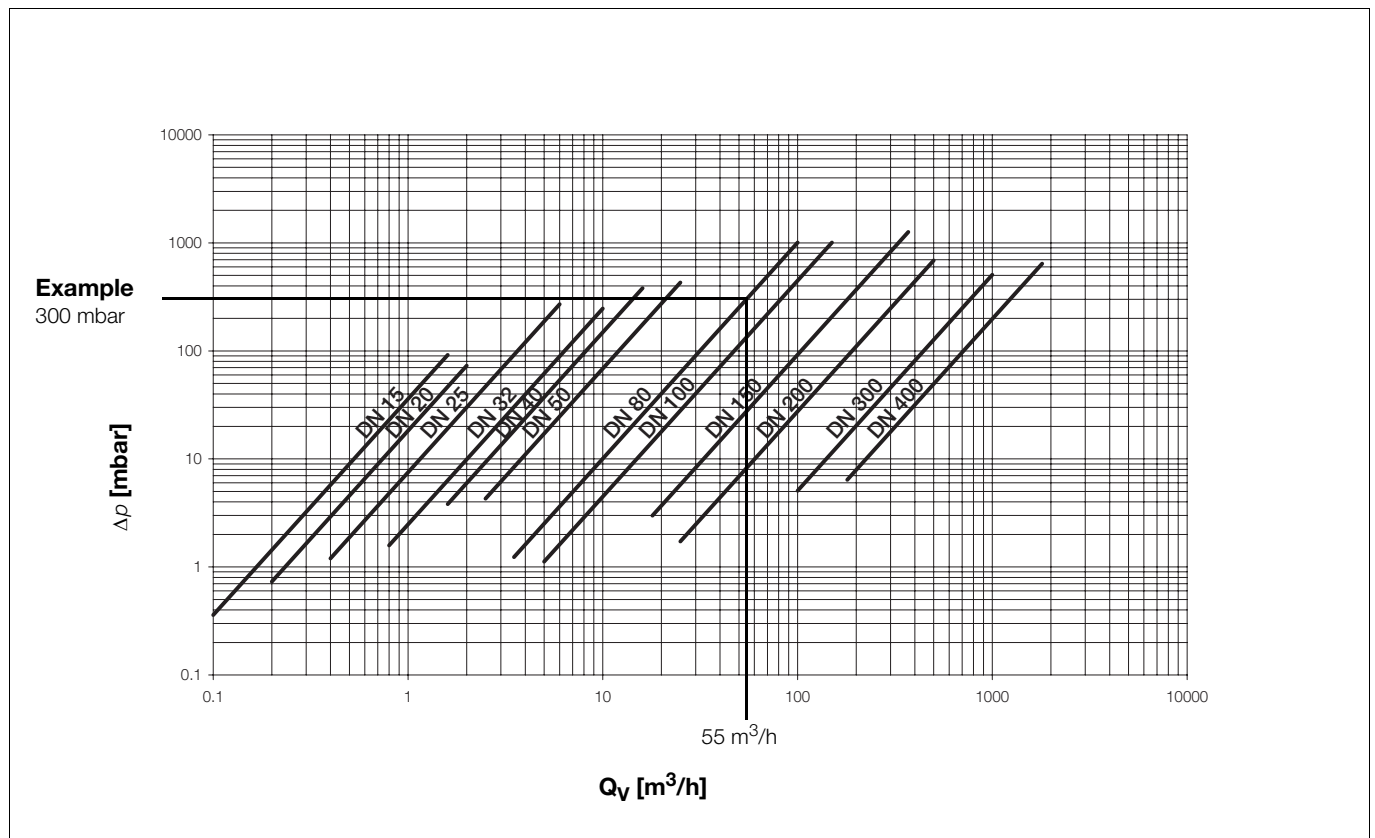

Fig. 19: Pressure Drop, Water (20 °C), 1013 mbar, ρ = 998 kg/m³

Flowrates, Gases/Steam

Meter Size DN	Inch	Q _v min [m ³ /h]	RangeMax [m ³ /h]	Frequency [Hz] at RangeMax
15	1/2"	2.5	16	1900
20	3/4"	5	25	1200
25	1"	5	50	1200
32	1-1/4"	8	130	1300
40	1-1/2"	12	200	1400
50	2"	18	350	1200
80	3"	60	850	690
100	4"	65	1500	700
150	6"	150	3600	470
200	8"	200	4900	320
300	12"	530	10000	160
400	16"	1050	20000	150

Tbl. 6: Flowrates, Gases/Steam for ρ = 1.2 kg/m³

Example for gases:

Find the flowmeter size for metering 2540 m³/h (q_n) CO₂-Gas; temperature = 85 °C, pressure = 5 bar a. For details see Page 18 „Meter Size Selection“

ρ_n = 1.97 kg/m³ (CO₂)

- Convert ρ_n --> ρ : ρ = 7.4 kg/m³
- Convert m³/h (q_n) --> m³/h (q_v): Q_v = 676 m³/h (q_v)
--> Selection: DN 80[3"] (Q_v max = 1200 m³/h) (q_v)
- Pressure drop for ρ = 7.4 kg/m³: Δp' = 340 mbar
- Flow range start for ρ = 7.4 kg/m³ (from Fig. 20):
Q_vmin = 29 m³/h, convert m³/h (q_v) --> m³/h (q_n):
Q_vmin = 109 m³/h (q_n)

Pressure Drop Gases/Steam

See Fig. 21 for air (at 20 °C, 1013 mbar, ρ = 1.2 kg/m³). For other fluid densities the pressure drop can be calculated using the following equation:

$$\Delta p' = \frac{\rho}{1,2} \times \Delta p$$

Δp' = Pressure drop fluid [mbar]

Δp = Pressure drop air [mbar] (from Fig. 21)

Normal Density for Various Gases:

Gas	Normal Density [kg/m ³]
Acetylene	1.172
Air	1.290
Ammonia	0.771
Argon	1.780
Butane	2.700
Carbon dioxide	1.970
Carbon monoxide	1.250
Ethane	1.350
Ethylene	1.260
Hydrogen	0.0899
Methane	0.717
Natural gas	0.828
Neon	0.890
Nitrogen	1.250
Oxygen	1.430
Propane	2.020
Propylene	1.915

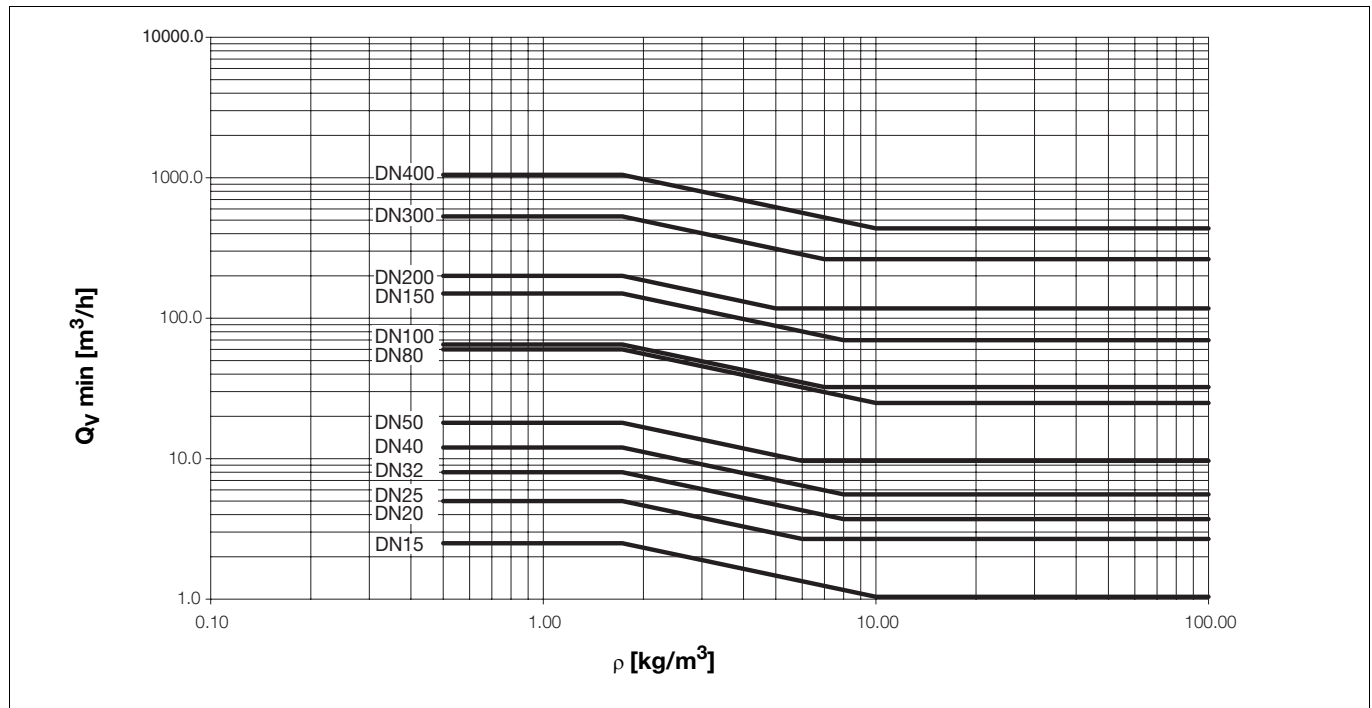

Fig. 20: Minimum Flowrate, Gases/Steam as a Function of the Fluid Density

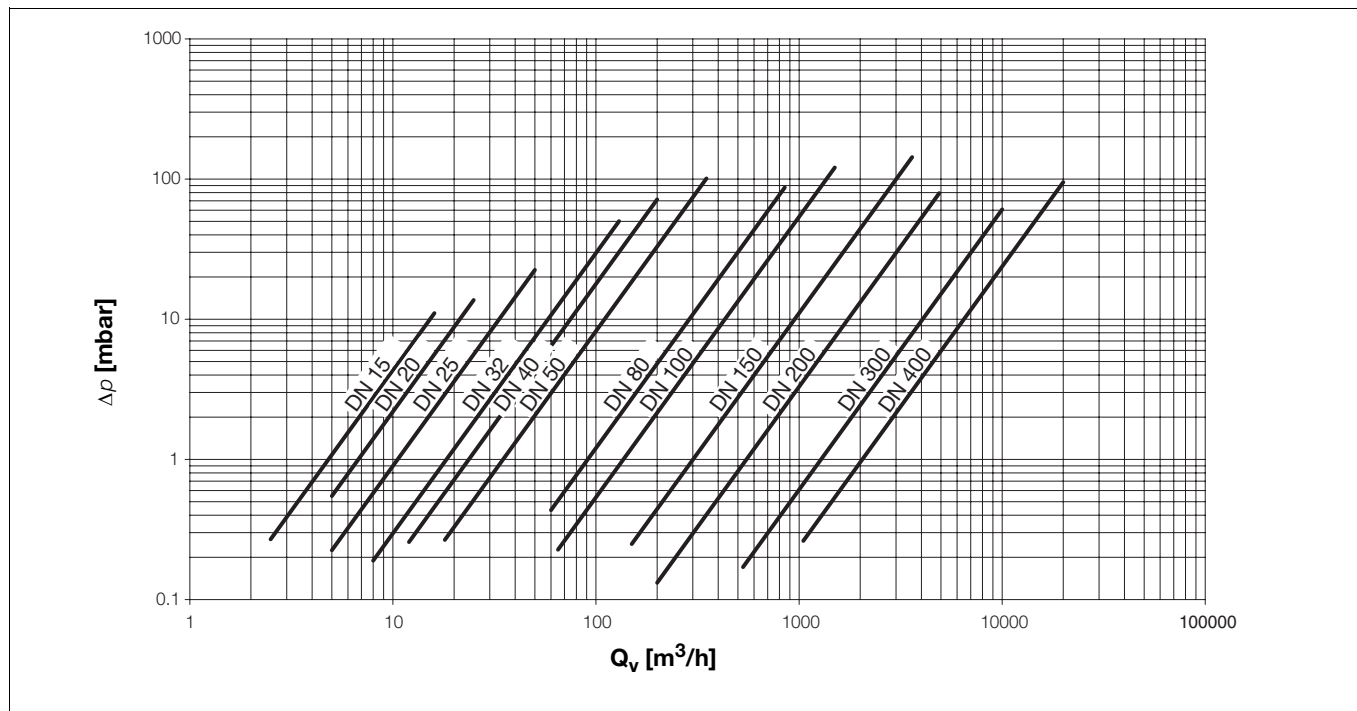

Fig. 21: Pressure Drop Air (20 °C, 1013 mbar, $\rho = 1.205 \text{ kg/m}^3$)

Flowrates, Saturated Steam [kg/h]

Example for saturated steam:

Find the flow range for DN 50[2"] at 7 bar a.

--> from Tbl. 7: DN 50[2"]: 66 - 1285 kg/h

Additional information: Sat. steam temp.= 165 °C
Sat, steam density = 3.67 kg/m³

p[bar a] Meter Size	0.5	1	1.5	2	3	4	5	6	7	8	9	10	12	15	25	30	35	40
DN15 1/2" min	2	2	3	3	4	4	4	5	5	6	6	6	7	8	11	13	15	17
max	5	9	14	18	26	35	43	51	59	67	75	82	98	122	200	240	280	320
DN20 3/4" min	4.8	3	2.8	3	4	5	7	8	9	10	12	13	15	19	31.5	37.5	43.7	50
max	7.5	15	21.5	28	41	54	67	79	92	104	117	129	153	190	312.5	375	437.5	500
DN25 1" min	9.7	7	5.7	6	8	11	13	16	18	21	23	26	31	38	62.5	75	87.5	100
max	15	30	43	56	83	108	134	159	184	208	233	258	307	380	625	750	875	1000
DN32 1-1/4" min	31.3	15.2	12.3	12.7	17.8	23.7	29.6	34.7	38.9	54.2	51.6	56.7	67.7	83.8	137.5	165	192.5	220
max	39	77	111.8	147	215	281	347	412	477	541	606	670	797	988	1625	1950	2275	2600
DN40 1-1/2" min	6.9	9.7	11.7	13.4	19	24.9	30.7	36.5	42.3	41.9	53.6	59.2	70.5	87.5	143.8	112.5	201.3	230
max	63	1239	180	237	346	453.6	561	665	770	873	978	1081	1287	1596	2625	3150	3675	4200
DN50 2" min	34.9	25	20.6	20	30	39	48	57	66	75	84	93	110	137	225	270	315	360
max	105	207	301	395	578	756	935	1110	1285	1456	1631	1803	1803	2660	4375	5250	6125	7000
DN80 3" min	77.6	55	45.8	45	66	86	107	127	147	166	186	206	245	304	500	600	700	800
max	255	502	731	960	1403	1836	2270	2695	3120	3536	3961	4378	5211	6460	10625	12750	14875	17000
DN100 4" min	126.1	90	74.4	73	107	140	174	206	239	270	303	335	398	494	812.5	975	1137.5	1300
max	450	885	1290	1694	2475	3240	4005	4755	5505	6240	6990	7725	9195	11400	18750	22500	26250	30000
DN150 6" min	232.8	166	137.4	135	198	259	320	380	440	499	559	618	736	912	1500	1800	2100	2400
max	1110	2182	3181	4181	6105	7992	9879	11779	13679	15579	17479	19379	22681	28120	46250	55500	64750	74000
DN200 8" min	388	277	229	226	330	432	534	634	734	832	932	1030	1226	1520	2500	3000	3500	4000
max	1500	2950	4300	5645	8250	10800	13350	15850	18350	20800	23300	25750	30650	38000	62500	75000	87500	100000
DN300 12" min	776	553	458	452	660	864	1068	1268	1468	1664	1864	2060	2452	3040	5000	6000	7000	8000
max	3000	5900	8600	11290	16500	21600	26700	31700	36700	41600	46600	51500	61300	76000	125000	150000	175000	200000
DN400 16" min	1940	1383	1146	1129	1650	2160	2670	3170	3670	4160	4660	5150	6130	7600	12500	15000	17500	20000
max	6000	11800	17200	22580	33000	43200	53400	63400	73400	83200	93200	103000	122600	152000	250000	300000	350000	400000
Density ρ_{sat} [kg/m ³]	0.3	0.59	0.86	1.13	1.65	2.16	2.67	3.17	3.67	4.16	4.66	5.15	6.13	7.6	12.5	15	17.5	20
Temp. T _{sat} [°C]	81.3	99.6	111.4	120	133	144	152	159	165	170	175	180	188	198	224	234	242	250

Tbl. 7: Saturated Steam Flow Ranges

Specifications Swirl Flowmeter FS4000-ST4/SR4 (TRIO-WIRL S)

Flowrate Measurement Accuracy and Reproducibility

Accuracy (incl. converter), linear flow range beginning at Re min (see Tbl. 8)

≤ ± 0.5 % of rate (at reference conditions)

Reproducibility

≤ 0.2 % of rate

Meter Size		Re min
DN	Inch	
15	½"	2100
20	¾"	3500
25	1"	5200
32	1-1/4"	7600
40	1-1/2"	13500
50	2"	17300
80	3"	15000
100	4"	17500
150	6"	43000
200	8"	44000
300	12"	115000
400	16"	160000

Tbl. 8: Minimum Reynolds No. (Re min) for Linear Flow Range Start

Reference Conditions for Flow Metering

Flow range setting:	$0.5 \cdot Q_{vmax}^{DN} \dots 1 \cdot Q_{vmax}^{DN}$
Ambient temperature:	20 °C +/- 2K
Humidity:	65 % rel. humidity +/- 5 %
Barometric press.:	86 kPa 106 kPa
Supply power:	24 VDC
Signal cable length:	10 m (only FS4000-SR4)
Current output load:	250 Ohm (only for 4-20mA)
Calibration fluid:	Air: 20 °C, atmospheric press. Water: approx. 20 °C, 2 bar
Calibration loop internal diameter:	Same as meter inside diameter
Unobstructed str. upstream section:	3 x D
Downstream section:	1 x D
Pressure tap:	Pressure tap at primary
Temperature measurement:	3xD downstream.

Overload:

Gases:

15 % over maximum flowrate

Liquids:

15 % over maximum flowrate:

Note: Cavitation may not exist

Temperature Measurement Accuracy and Reproducibility

Accuracy (incl. converter)

± 2 °C

Reproducibility

≤ 0.2 % of rater

Allowable Pipeline Vibrations:

Guide Values:

The acceleration values listed below are to be used only as guidelines. Since the actual value is a function of the flowmeter size, the flowrate within the flow range and the frequency of the vibrations, these acceleration values can only be used as a guideline.

Liquids: max. 0.3 g 0 - 130 Hz

Gases/Steam: max. 0.3 g 0 - 130 Hz

Process Connections / Operating Pressure

Flanges: DN15-DN200: DIN PN 10 to 40
1/2" - 8" ASME Class 150/300
DN300-DN400: DIN PN 10 to 16
12" - 16" ASME Class 150

Additional designs upon request.

Flanged design: DIN PN 10 to 40, Option to PN 160
ANSI Class 150/300, Option to CI 1200

Additional designs upon request.

Materials:

Meter Housing

SS No. 1.4571[316Ti], option: Hastelloy-C

Flanges

SS No. 1.4571[316Ti], option: Hastelloy-C

In-/Outlet Guide Body

SS No. 1.4571[316Ti], option: Hastelloy-C

Sensor

SS No. 1.4571[316Ti], option: Hastelloy-C

Sensor Gaskets

Kalrez O-Ring: 0 °C to 280 °C

Kalrez (6375) O-Ring: -20 °C to 275 °C

Viton O-Ring: -55 °C to 230 °C

PTFE O-Ring: -55 °C to 200 °C

Graphite: -55 °C to 280 °C

Other designs upon request.

Housing, Electronic Module

Die cast Alum., painted

Weight:

see Dimensions

Fluid Temperature (Standard and Ex):



Attention!

Observe the specifications in the Chapter Explosion Protection starting on Page 32

-55 °C to +280 °C (Standard)

Allowable temperatures of gaskets must be considered

Ambient Conditions:

Climate Resistance (per DIN 40040)

Ex-Prot. Model	Allow. Ambient Temperature Range	Climate Class	
		Standard	Climate Resistance
None / ST40 & SR40	-20° C ... +70 °C	Z ¹ SG ²⁾	Z ¹ SA
	-55 °C ... +70 °C	FSG ²⁾	FSA
Ex ib / ST41 & SR41	-20 °C ... +70 °C	Z ¹ SG ²⁾	Z ¹ SA
	-55 °C ... +70 °C	FSG ²⁾	FSA
Ex ia / ST4A & SR4A	-20 °C ... +60 °C	Z ¹ UG ²⁾	Z ¹ UA
	-40 °C ... +60 °C	GUG ²⁾	GUA
Ex d / ST42 & SR42	-20 °C ... +60 °C	Z ¹ UG ²⁾	Z ¹ UA
	-40 °C ... +60 °C	GUG ²⁾	GUA
FM ST43 & SR43	-20 °C ... +70 °C	Z ¹ SG ²⁾	Z ¹ SA

1) Z = Lower ambient temperature limit = -20 °C

2) G = Relative humidity max. 85 %, yearly average ≤ 65 %

Allowable Operating Pressure as a Function of the Fluid Temperature

Process Connections DIN-Flanges

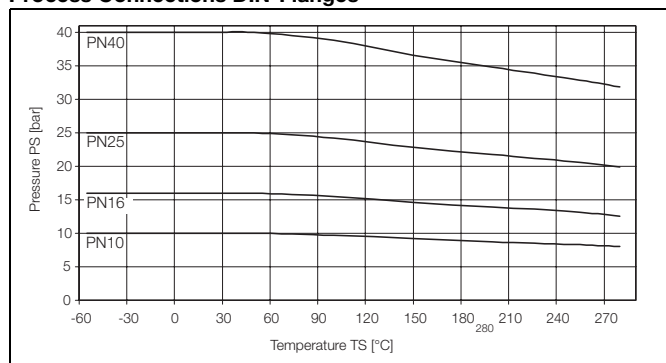

Process Connections ASME-Flanges

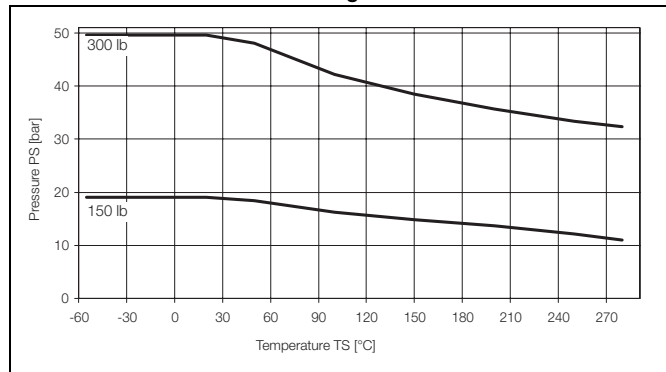

Ambient / Fluid Temperatures:

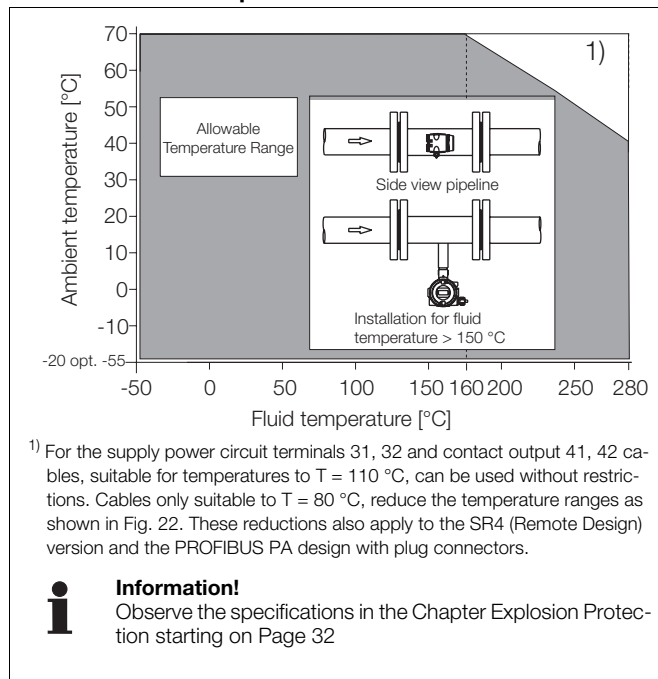

Fig. 22: Ambient / Fluid Temperature Relationship

Information!
For temperatures < 0 °C and > 55 °C the readability of the display may be compromised. The functionality and the outputs of the instrument are unaffected.
Ambient temperatures < -20 °C see Ordering Information.

Converter specifications begin on Page 28

Installation Swirl Flowmeter FS4000-ST4/SR4 (TRIO-WIRL S)

The flowmeter primary should be installed in the pipeline taking into consideration the following information.

In- and Outlet Sections

Based on the operating principles the Swirl Flowmeter, it essentially does not require any in- or outlet straight sections. Fig. 23 shows the in- and outlet sections for various piping conditions. No additional in- or outlet sections are required when single or double elbows with a radius larger than $1.8 \times D$ are installed up- or downstream from the instrument. Likewise, no additional in- or outlet sections are required downstream from flanged reducers per DIN 28545 ($a/2 = 8^\circ$).

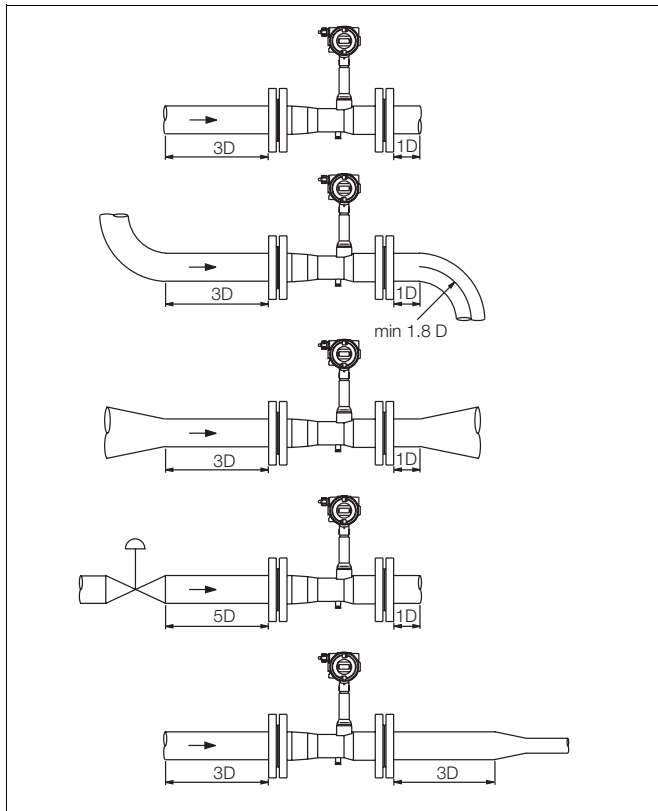

Fig. 23: In- and Outlet Sections

Information for Installation of Regulating and Control Devices

If the system utilizes a piston pump or compressor to produce the flow, (pressures for liquids > 10 bar) water hammer may occur when the valve is closed. In this case it is essential that the valves be installed upstream of the flowmeter. Otherwise a suitable dampening device (e.g. compression tank when using a compressor) should be provided. Pressure and temperature measurements should be installed as shown in Fig. 25. To use the internal temperature measurement see information in the Chapter Converter.

Supplementary Installation Information

- For liquids assure that the flowmeter primary is always completely filled with fluid.
- In horizontal installations with fluid temperatures $> 150^\circ\text{C}$ see Fig. 24 for installation requirements.
- If gas bubbles may be present a gas separator should be provided.
- For installation in long pipelines susceptible to vibrations, these should be damped up- and downstream of the instrument.

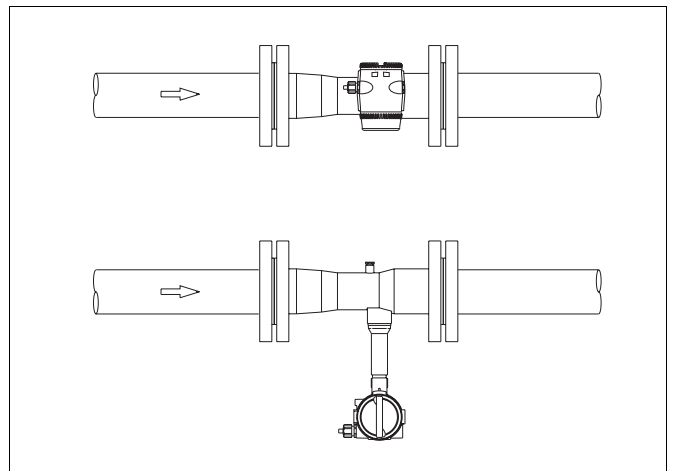

Fig. 24: Installation for High Fluid Temperatures

Pressure and Temperature Measurements

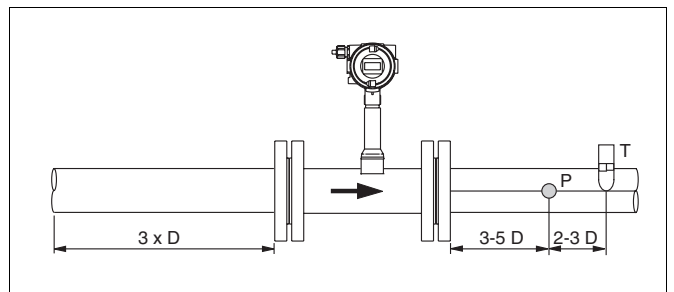
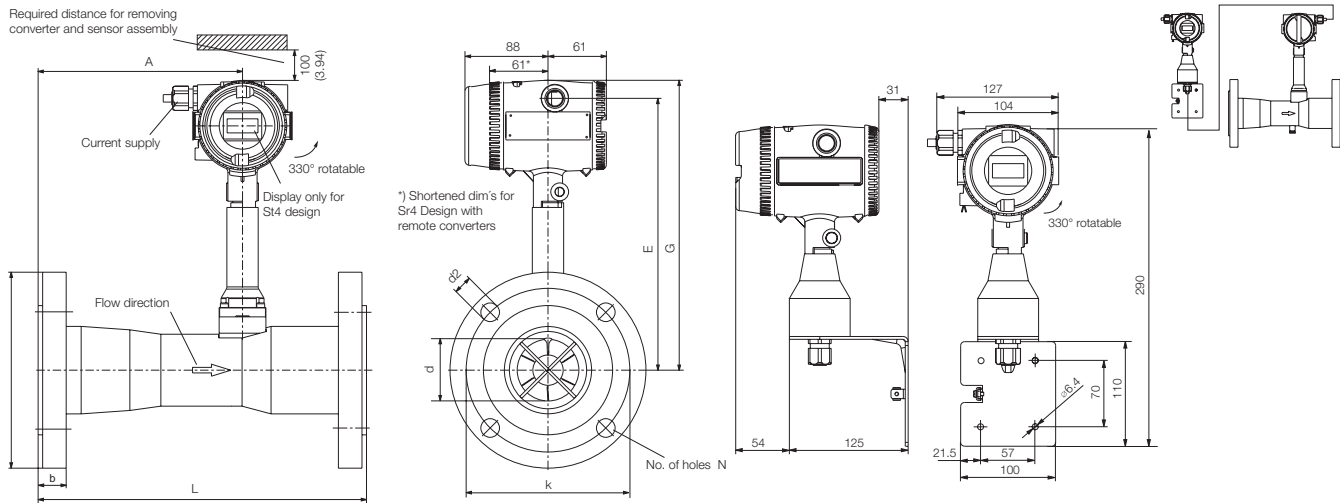

Fig. 25: Installation with Pressure and Temperature Measurements

Dimensions Swirl Flowmeter FS4000-ST4/SR4 (TRIO-WIRL S)



Converter FS4000-SR4
 in wall mount housing

All dim's in mm

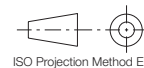

MB-10-2004

Meter Size DN	Pressure Rating PN	L ¹⁾	G	E	A	D	k	d2	d	b	N	Weight [kg]
15	10-40	200	319	300	83	95	65	14	17.3	16	4	5.8
20	10-40	120	322	303	68	105	75	14	22.6	18	4	2.4
25	10-40	150	321	302	67	115	85	14	28.1	18	4	3.5
32	10-40	150	319	300	68	140	100	18	37.1	18	4	4.7
40	10-40	200	323	304	79	150	110	18	42.1	18	4	8
50	10-40	200	326	307	106	165	125	18	51.1	20	4	7.2
80	10-40	300	329	310	159	200	160	18	82.6	24	8	12.2
100	10-16	350	333	314	189	220	180	18	101.1	22	8	14.2
	25-40	350			189	235	190	22	101	24		18
150	10-16	480	357	338	328	285	240	22	150.1	28	8	28.5
	25-40	480			328	300	250	26	150.1	28		34.5
200	10/16	600	377	358	436	340	295	22	203.1	24/28	8/12	50
	25/40	600			436	360/375	310/320	26/30	203.1	38/48	12	59/66
300	10/16	1000	423	404	662	445/460	400/410	30/33	309.7	26/28	12	171/186
400	10/16	1274	459	440	841	565/580	515/525	36/39	390.4	26/32	16	245/266

Meter Size Inch	Pressure Rating Class	L ¹⁾	G	E	A	D	k	d2	d	b	N	Weight [kg]
1/2"	150	200	319	300	83	88.9	60.5	15.9	15.8	11.2	4	5.3
	300	200			83	95.2	66.5			14.2		5.8
3/4"	150	120	322	303	68	98.4	70	15.9	22.6	13	4	2.1
	300	120			68	117.5	82.5	19	22.6	15.9		3.0
1"	150	150	321	302	67	108	79.4	15.9	28.1	14.2	4	3.4
	300	150			67	124	88.9	19	28.1	17.5		3.6
1-1/4"	150	150	319	300	68	118	89	16	37.1	16	4	3.7
	300	150			68	133	98.4	19		19		5.4
1-1/2"	150	200	323	304	79	127	98.4	16.9	42.1	17.5	4	6.8
	300	200			79	155.6	114.3	22.6	42.1	20.6		8.9
2"	150	200	326	307	106	152.4	120.6	19	51.1	19.1	4	7.1
	300	200			106	165	127		51.1	22.3		8
3"	150	300	329	310	159	190.5	152.4	19	82.6	23.9	4	11.7
	300	300			159	209.5	168.3	22.2	82.6	28.4		8
4"	150	350	333	314	189	228.6	190.5	19	101.1	23.9	8	18.0
	300	350			189	254	200	22.2	101.1	31.7		27.5
6"	150	480	357	338	328	279.4	241.3	22.2	150.1	25.4	8	30.0
	300	480			328	317.5	269.9	22.2	150.1	36.5		12
8"	150	600	377	358	436	343	298.4	22.2	203.1	28.4	8	45.0
	300	600			436	381	330.2	25.4	203.1	46.6		12
12"	150	1000	423	404	662	482.6	431.8	25.4	309.7	31.8	12	182
16"	150	1274	459	440	841	596.9	540	28.6	390.4	37	16	260

Fig. 26: Dimensions FS4000-ST4/SR4

Ordering Information Swirl Flowmeter FS4000 (TRIO-WIRL S)

Ordering Number		S																		
Instrument Design																				
Compact		T																		
Remote		R																		
Series			4																	
EEx Approvals (function of communication option)																				
None																				
CENELEC „Intrinsic Safety“ HART ¹⁾																				
CENELEC „Pressure Tight“ HART ²⁾																				
FM-Approval (Class 1 / Div. 1) HART																				
CSA-Approval HART ⁵⁾																				
CENELEC „Intrinsic Safety“ PA/FF ³⁾																				
Others																				
Process Connections																				
Flanges																				
Flanges with groove (DIN 2512)																				
Others																				
Fluid																				
Liquid																				
Gas																				
Steam																				
Oxygen ⁴⁾																				
Materials																				
Housing		In-/Outlet Guide Body Sensor																		
SS 1.4571[316Ti]		SS 1.4571[316Ti]		SS 1.4571[316Ti]																
SS 1.4571[316Ti]		Hastelloy C		SS 1.4571[316Ti]																
Hastelloy C		Hastelloy C		Hastelloy C																
SS 1.4571[316Ti]		Hastelloy C		Hastelloy C																
Meter Sizes		Standard Pressure Rating																		
DN 15 / 1/2"		PN 40																		
DN 20 / 3/4"		PN 40																		
DN 25 / 1"		PN 40																		
DN 32 / 1-1/4"		PN 40																		
DN 40 / 1-1/2"		PN 40																		
DN 50 / 2"		PN 40																		
DN 80 / 3"		PN 40																		
DN 100 / 4"		PN 16																		
DN 150 / 6"		PN 16																		
DN 200 / 8"		PN 16																		
DN 300 / 12"		PN 10																		
DN 400 / 16"		PN 10																		
Pressure Rating																				
DIN PN 10																				A
DIN PN 16																				B
DIN PN 25 (<DN 300)																				C
DIN PN 40 (<DN 300)																				D
ASME CL 150																				Q
ASME CL 300 (<12")																				R
Others																				Z
Gasket Surface Roughness⁶⁾																				
Rz 16 µm																				B
Rz 63 µm																				D
Others																				Z

- 1) Design also for use in Ex-Zone 2 (II 3G EEx nA [L] IIC T4) and for use in areas with combustible dust (II 2D T85 °C ... Tmed IP67) approved.
- 2) Design also for use in Ex-Zone 2 (II 3G EEx nA [L] IIC T4) and Zone 1 (II 2G EEx ib IIC T4) and for use in areas with combustible dust (II 2D T85 °C ... Tmed IP67) approved
- 3) Also for use in areas with combustible dust (II 2D T85 °C ... Tmed IP67) approved.
- 4) Flowmeter primary cleaned and marked for Oxygen service.
- 5) Upon request
- 6) Roughness

Process Connections	Flanges/Flanges with groove
Pres. Rating	
PN 10-40	Rz63 (41-160 µm)
CL150 - 300	Rz16 (12.5-22 µm)

Other roughnesses upon request

Continued Ordering Information

Ordering Number	S																			
Sensor Design																				
Standard single sensor (Tmax = 280 °C)	1																			
Standard single sensor with integr.temperature sensor (Tmax = 280 °C)	2																			
Double sensor (Tmax = 280 °C) ≥ DN 50 ⁵⁾⁷⁾	3																			
Double sensor (Tmax = 280 °C) with integr.temperature sensor ≥ DN 50 ⁵⁾⁷⁾	4																			
Temperature Range Fluid/Gaskets																				
Graphite -55 °C to 280 °C	1																			
Kalrez (3018) O-Ring 0 °C to 280 °C	3																			
Viton O-Ring -55 °C to 230 °C (not for steam)	4																			
PTFE O-Ring -55 °C to 200 °C	5																			
Kalrez (6375) O-Ring -20 °C to 275 °C ⁷⁾	8																			
Certifications																				
None		A																		
Inspection Certificate EN10204-3.1B ⁷⁾		B																		
Material traceability per EN10204-3.1B and Pressure Test per AD2000		C																		
Pressure Test per AD2000 ⁷⁾		D																		
Others		Z																		
Communication																				
With display with HART																			2	
With display with PROFIBUS PA ⁷⁾																			4	
With display with FOUNDATION Fieldbus ⁷⁾																			6	
Name Plate Language																				
German																			G	
English																			E	
French																			F	
Design Level/Software Level (specified by ABB)																				
*																				
Accessories																				
None																				0
2" Pipe mount (only FS4000-SR4)																				1
Climate resistant Version																				2
Climate resistant Version + 2" Pipe mount (only FS4000-SR4)																				3
Operating Mode																				
Continuous flowrate																				A
Cable Connector																				
M20 x 1.5 (not with EEx-Approval "2" or "3" or „4“)																				A
1/2" NPT																				B
Plug connection M12 (only with communication option: "4"/EEx-Approval "0" or "A" ^{7) 8) 9)}																				C
Calibration																				
Test report																				A
Calibration report																				B
Gas / & liquid test report																				C
Gas / & liquid calibration report																				D
Ambient Temperature Range																				
-20 °C to +70 °C (only for Ex-Approval „0“, „1“, „3“ or „A“ ¹⁰⁾)																				1
-55 °C to +70 °C (only for Ex-Approval „0“, „1“ ¹⁰⁾)																				2
-20 °C to +60 °C (only for Ex-Approval „2“)																				3
-40 °C to +60 °C (only for Ex-Approval „2“ or „A“ ¹⁰⁾)																				4
Others																				9

7) Not for designs with FM- or CSA-Approval
 8) Socket (Type EPG300) is not included with shipment. Please order separately (see Specification 63-6-41 DE)
 9) Not for use in Ex-Zone 21/22
 10) Suitable for Ex-Zone 21/22 only in the range -20 °C to +60 °C

Specifications Converter

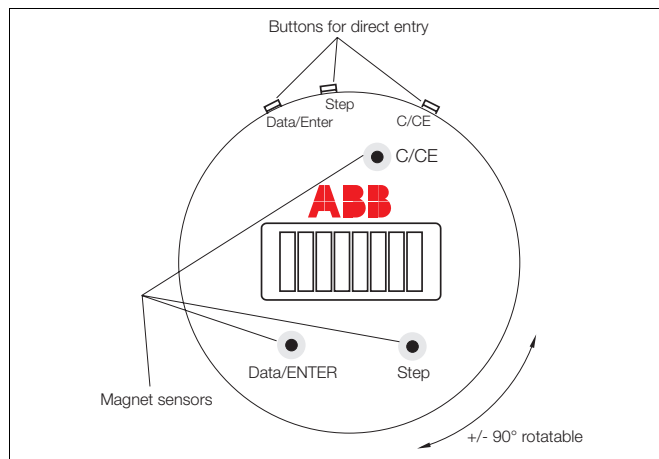

Fig. 27: Converter Keypad and Display

Flow Ranges

The flow range end value can be set anywhere between the max. possible end value RangeMax and 0.15 x RangeMax. For Vortex Flowmeter FV4000 flow ranges see Pages 5 and 6 or for Swirl Flowmeter FS4000 see Pages 19 and 20.

Parameter Settings

Data is entered using the 3 buttons (not in the Ex-Design Ex „d“) or directly using a Magnet Stick from the outside without opening the housing.

The data is entered in a clear text dialog with the display or by using the digital communication modes HART-Protocol, PROFIBUS PA or FOUNDATION Fieldbus.

Flowrate Operating Modes

Based on the design ordered, (with or without a Pt100 sensor) the following operating modes can be selected:

Fluid Liquid:

- Actual flowrate,
- Mass flowrate at a constant or temperature dependent density

Fluid Gas/Steam:

- Actual flowrate,
- Mass flowrate at a constant or temperature dependent density (at constant pressure),
- Normal flowrate at a constant or temperature dependent density (at constant pressure),
- Mass flowrate of saturated steam at temperature dependent density

Data Security

The totalizer values and the meter location parameters are stored in a FRAM (for 10 years without supplementary power) when the supply power is turned off or during a power outage.

Information:

The instrument satisfies the NAMUR-Recommendations NE21. Electromagnetic Compatibility of Equipment in Process or Laboratory Applications 5/93 and EMC Guideline 89/336/EWG (EN 50081-1, EN 50082-2).

Attention: When the housing is opened, the EMC and personnel contact protection is limited.

Damping

Settable between 1 and 100 s, corresponds to 5 τ .

$Q_{v \min}$ (low flow cutoff)

Settable between 0 and 10 % v. RangeMax (max. actual flowrate for the meter size). The actual low flow cutoff value is a function of the application and the installation.

Function Tests

Internal function tests incorporated in the software can be used to test the internal subassemblies. At start-up, a user selected the flowrate can be simulated (manual process control) for checking the current output (for designs with 4-20 mA) and the digital output (for the fieldbus designs). The contact output can be actuated to check its operation.

Electrical Connections

Screw terminals, plug connector for PROFIBUS PA (option)
cable connector: standard, Ex "ib"/Ex "ia": M20 x 1.5;
NPT 1/2" Ex "d": NPT 1/2"

Protection Class

IP 67 per EN 60529 / NEMA 4X

Display

High contrast LC-Display, 2 x 8 characters (4-20 mA design) or 4 x 16 characters (fieldbus design PROFIBUS PA / FOUNDATION Fieldbus). For display of the instantaneous flowrate, totalized flow values or fluid temperature (option).

In the 4-20 mA design it is possible using the multiplex mode to display 2 additional values (e.g. flowrate and totalized flow) quasi in parallel. In the fieldbus design up to 4 values can be displayed.

Example: (shown is the display for the 4-20 mA design)

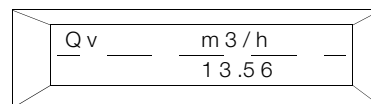

Actual flowrate

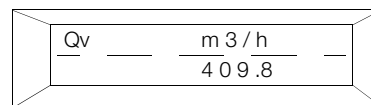

Actual totalized flow

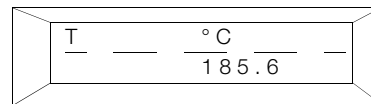

Fluid temperature

Error Messages in the Display

Automatic system monitoring with error diagnostics in clear text on the display with an error message.

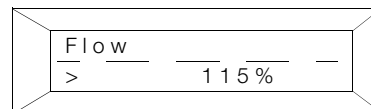

Contact Output terminals 41/42 (standard for all designs)

The function can be assigned in the software:

- Limit alarm for flowrate or temperature
- System alarm
- Pulse output: fmax: 100 Hz; t_{on} : 1 ms - 256 ms

Contact design:

- Standard, Ex "d" and FM design: Optocoupler $U_H = 16-30 V$
 $I_L = 2-15 mA$
- Ex "ib"/Ex "ia": Configured as a NAMUR-Contact

Specifications Converter - Electrical Interconnections for the Standard Design 4-20 mA/HART

2-Wire Design 4-20 mA/HART-Communication

The converter is designed in 2-Wire technology, i.e. the supply voltage and the current output (4-20 mA) utilize the same lines. A contact output, connected in parallel, is also available.

Supply Power (terminals 31/32)

Standard: 14 to 46 V DC Ex-Design: see Page 32.
Ripple: max. 5 % or $\pm 1.5 V_{pp}$



Power

< 1 W

a) Supply Power from a Central Power Source

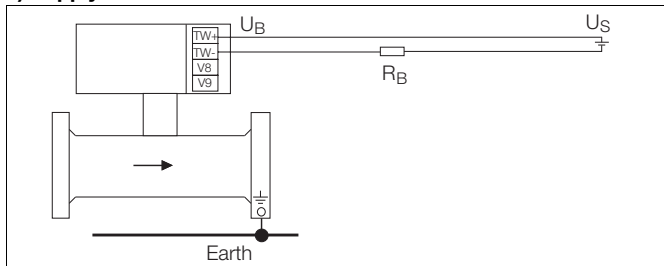

b) Supply Power from a Power Supply

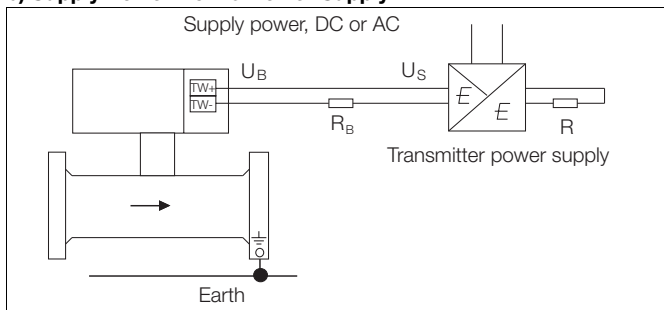

- U_B = Supply voltage = min. 14 V DC
- U_S = Source voltage = 14-46 V DC
- R_B = max. allow. load for power supply (e.g. indicator, load)
- R = max. allow. load for output circuit. Is defined by the power supply

c) Electrical Interconnections FV4000-VR4, FS4000-SR4

The flowmeter primary and the converter are separated from each other by a 10 m long signal cable. The signal cable is permanently connected to the converter and can be shortened as required. The supply power connection for the converter can be made as shown in a) or b) above.

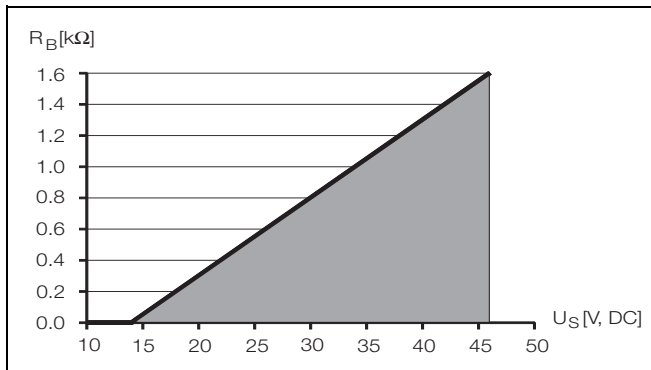
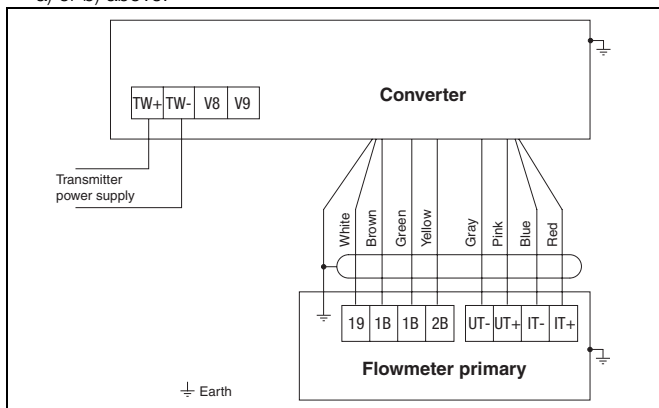

Current output load diagram; load vs. supply power

HART-Communication requires the smallest load, 250 Ohm

d) Electrical Interconnections Contact Output

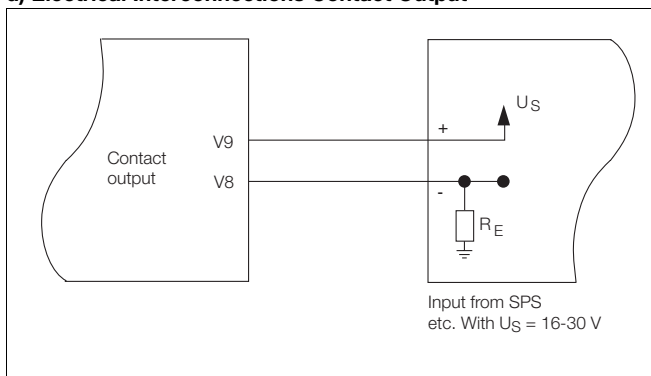

The load R_E is calculated using the available supply voltage U_S and the selected signal current as follows:

$$R_E = \frac{U_S}{I_B}$$

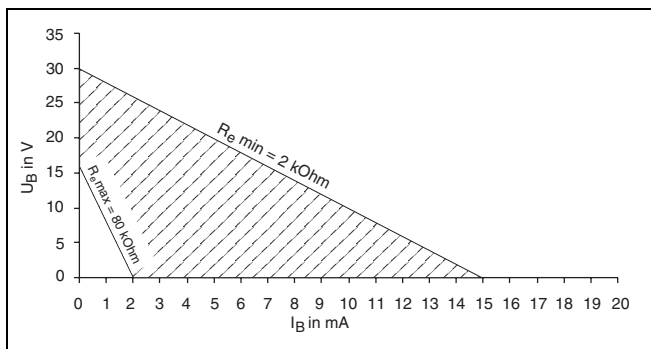

Contact Output Load Resistance as a Function of the Current and Voltage

Specifications - Electrical Interconnections for the PROFIBUS PA/FOUNDATION Fieldbus Designs

Communication HART-Protocol

The HART-Protocol is used for the digital communication between a process control system/PC, handheld terminal and the Vortex-Swirl flowmeters. All instrument and meter location parameters can be transmitted from the converter to the process control system or PC. In the reverse direction it is possible to configure and reconfigure the converter.

The digital communication utilizes a sine wave superimposed on the current output (4-20 mA), which does not affect any of the instruments connected to the output.

The SMART VISION program can be used to operate and configure the converter. SMART VISION is a universal communication software for intelligent field instruments, which utilizes FDT/DTM-Technology. There are various communication paths which can be used to exchange data with a complete palette of field instruments. The primary application goals are parameter indications, configuration, diagnosis, documentation and management for all intelligent field instruments which satisfy its communication requirements.

Transmission Mode

FSK-Modulation on the 4 - 20 mA current output per Bell 202 Standard. Max. signal amplitude 1.2 mA_{pp}.

Current Output Load

Min. >250 Ohm, max. 750 Ohm
Max. cable length, 1500 m AWG 24 twisted and shielded

Baudrate

1200 Baud
Logic 1: 1200 Hz
Logic 0: 2200 Hz

Current output at alarm
high = 22.4 mA

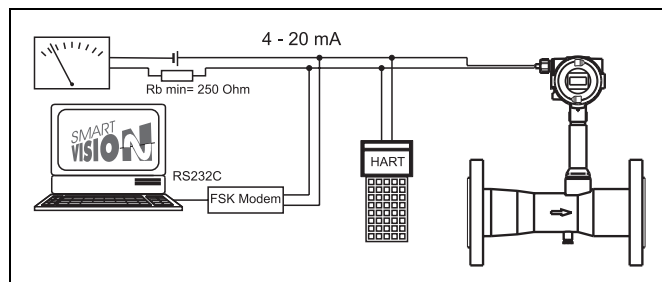

HART-Communication

2-Wire Design with Fieldbus Data Link

The converter of the Vortex-Swirl flowmeters is designed in 2-Wire technology, i.e. the supply voltage and the digital communication from the Fieldbus-Data Link utilize the same lines. A contact output, connected in parallel, is also available (description see Page 29). The entire set of stored data is maintained during a power outage. The SMART VISION program can be used to operate and configure the converter. SMART VISION is a universal communication software for intelligent field instruments, which utilizes FDT/DTM-Technology. There are various communication paths which can be used to exchange data with a complete palette of field instruments. The primary application goals are parameter indications, configuration, diagnosis, documentation and management for all intelligent field instruments which satisfy its communication requirements.

Common Specifications

Allowable Supply Voltage

9 V... 32 V (no Ex-Protection)

Current Consumption

Normal operating: 10 mA
FDE (Fault Disconnection Electronic): 13 mA

Ex-Design

See Page 33

Communication PROFIBUS PA

The converter is suitable for connection to a DP/PA segment coupler and the ABB Multi-Barriers MB204.

PROFIBUS PA Protocol

Output signal per EN 50170 Volume 2, PROFIBUS
Transmission technology IEC 1158-2/EN 61158-2
Transmission speed: 31.25 KByte/s
PROFIBUS Profile Version 3.0

Ident-No.

05DC hex

Function Blocks 2 x AI, 1 x TOT

GSD-Files

- PA139700 (1 x AI)
- PA139740 (1 x AI, 1 x TOT)
- ABB_05DC (2 x AI, 1 x TOT + manufacturer specific data)

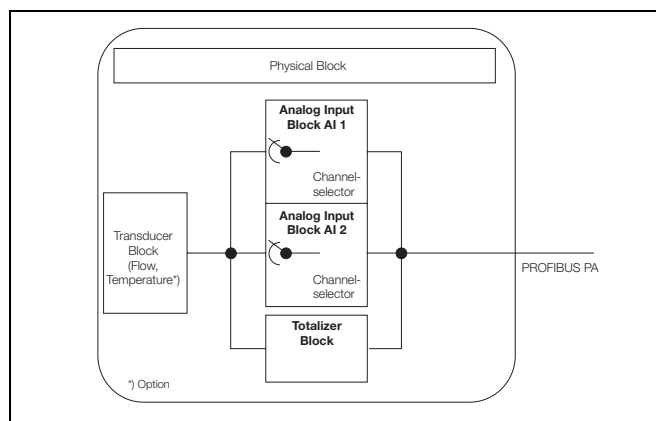

Block Structure for PROFIBUS PA

Communication FOUNDATION Fieldbus

The converter is suitable for connection to special power supplies, a Linking Device and the ABB Multi-Barriers MB204.

FOUNDATION Fieldbus Protocol

Output signal per FOUNDATION Fieldbus Protocol Specification 1.4 / ITK 4.01 for the H1 Bus
Transmission technology IEC 1158-2/EN 61158-2
Transmission speed: 31.25 KByte/s
Manufacturer ID: 0x000320
Device ID: 0x0015
Reg-Number: IT013600

Function Blocks: 2 x Analog Input
Stack: with LAS functionality

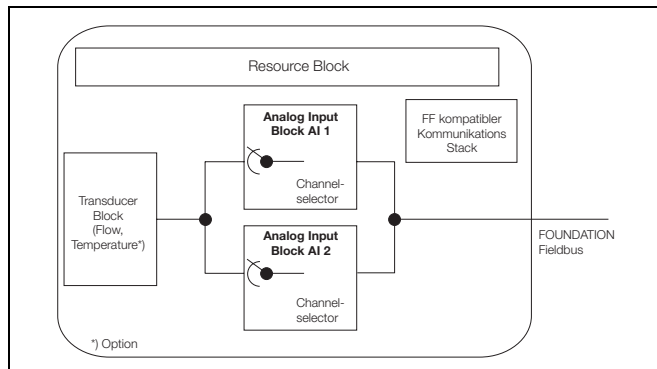

Block Structure for FOUNDATION Fieldbus

The output value (volume, normal or mass flowrate, totalizer or temperature) can be selected over the Channel Selector.

Connections

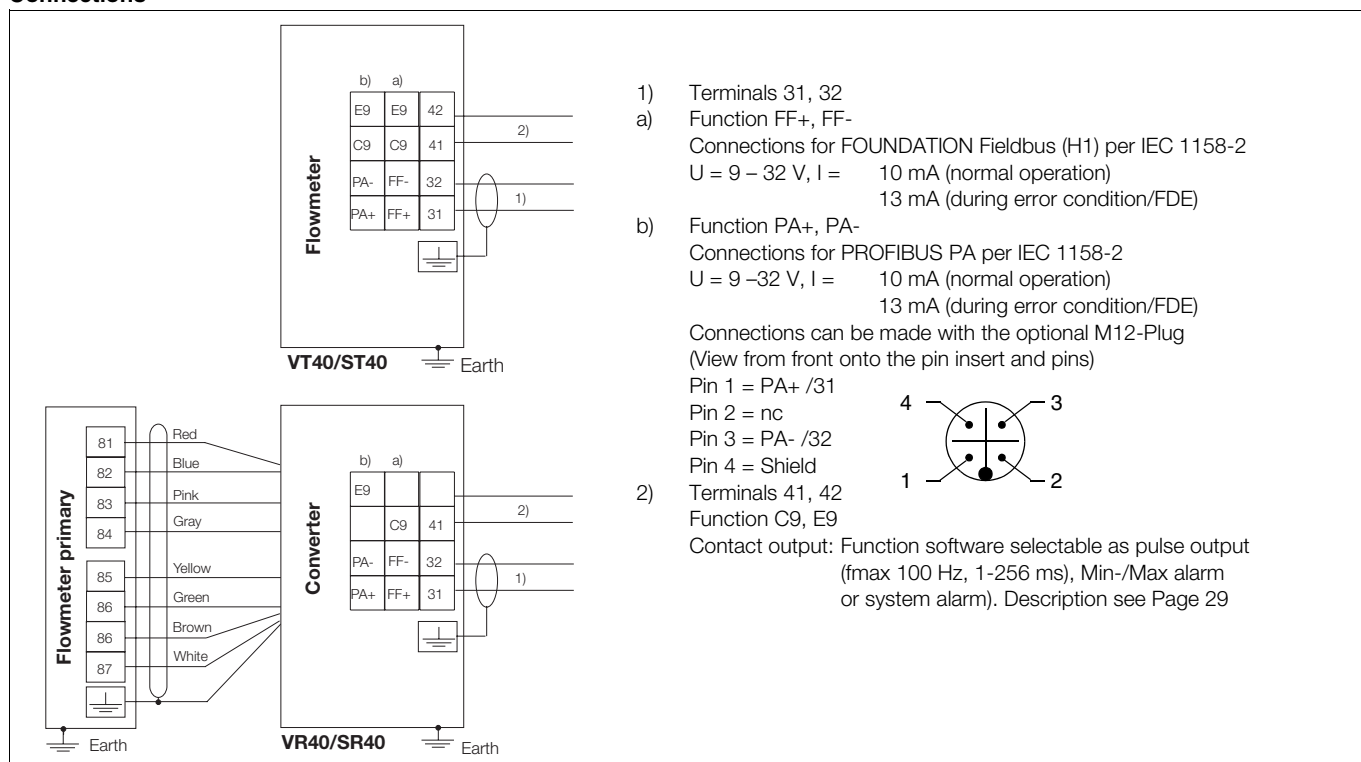

Fig. 28: Interconnection Diagram for PROFIBUS PA Connections

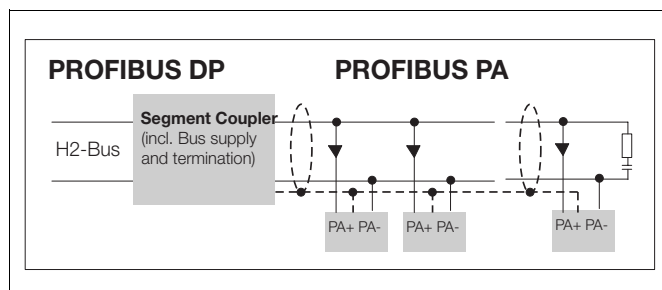

Fig. 29: Connection Example for PROFIBUS PA

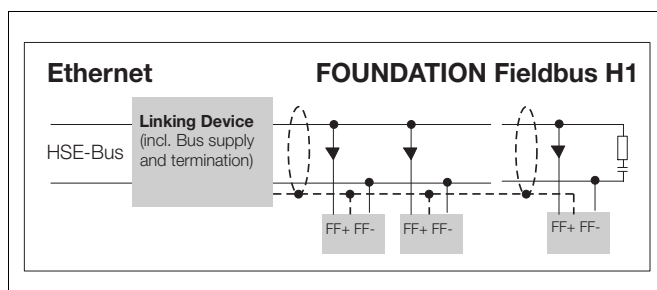

Fig. 30: Connection Example for FOUNDATION Fieldbus



Specifications Converter

Design EEx „ib“/EEx „n“ for VT41/ST41 and VR41/SR41 (4-20mA/HART)



The housing covers must be completely closed for operation in explosive areas.

EC-Type Examination Certificate TÜV 99 ATEX 1465

Identification:



II 2G EEx ib IIC T4
II 3G EEx nA [L] IIC T4
II 2D T 85 °C ... T_{med} IP67

Connections

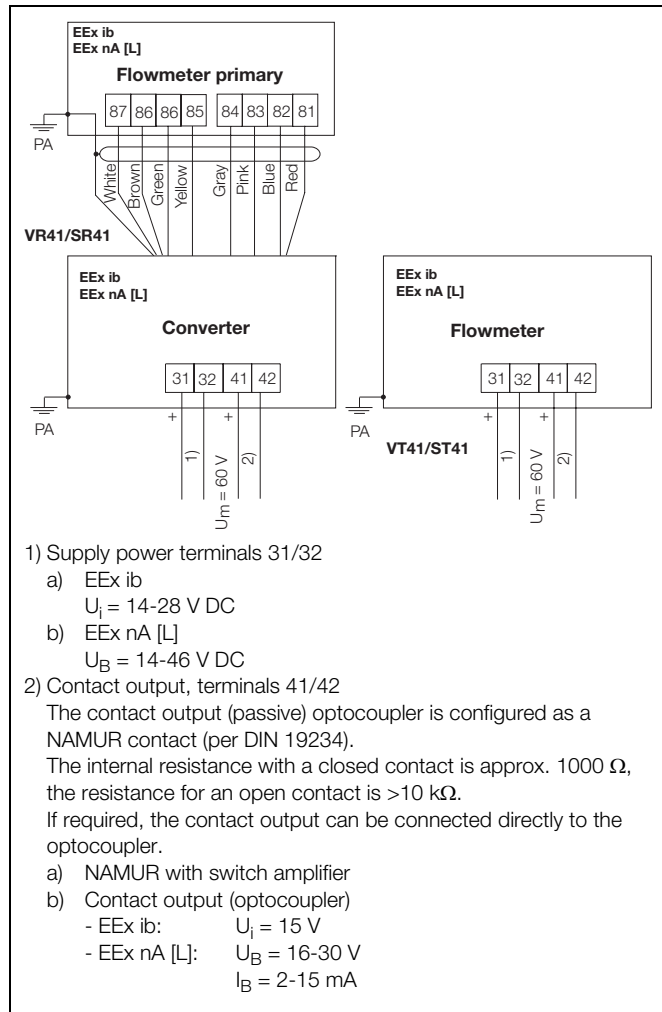
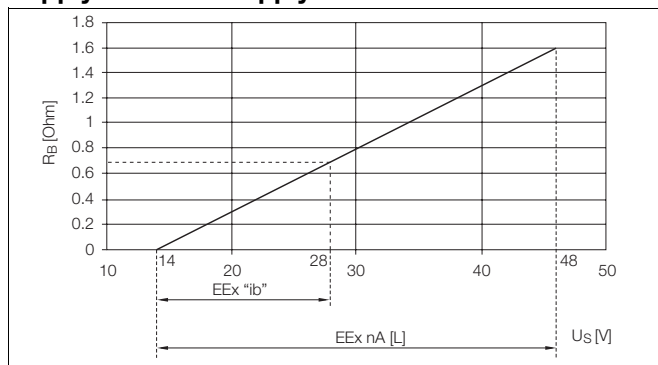

Fig. 31: Interconnection Diagram VT41/ST41 and VR41/SR41



The installation information per EN 60079-14 is to be observed. At start-up, Standard EN 50281-1-2 for use in areas with combustible dust must be considered. After the power is turned off, a period of $t > 2$ minutes should elapse before the converter housing is opened.

**Terminals 31/32
Supply Power or Supply Current**



The minimum voltage U_S of 14 V is based on a load of 0 Ω

U_S = Supply voltage

R_B = Maximum allow. load in the supply circuit
e.g. indicator, recorder or line resistance

Ex-Approval Specifications VT41/ST41 / VR41/SR41

Supply Circuit	Terminals 31,32
Ignition Type $U_m = 60 \text{ V}$	II 2G EEx ib IIC T4/ $T_{amb} = (-55 \text{ °C}) -20 \dots +70 \text{ °C}$ $U_i = 28 \text{ V}$ $I_i = 110 \text{ mA}$ $P_i = 770 \text{ mW}$ effective internal capacitance: 14.6 nF effective internal capacitance to earth: 24.4 nF effective internal inductance: 0.27 mH
Ignition Type $U_m = 60 \text{ V}$	II 3G EEx nA [L] IIC T4/ $T_{amb} = (-55) -20 \dots +70 \text{ °C}$ $U_B = 14-46 \text{ V}$
Ignition Type $U_m = 60 \text{ V}$	II 2D T 85 °C ... T _{med} IP67/ $T_{amb} = -20 \text{ °C} \dots +60 \text{ °C}$

Recommended Transmitter Power Supplies	
ABB Automation	Contrans I V 17151-62
Digitable, MTL, Pepperl+Fuchs, etc.	Various types

Contact Output	Terminals 41, 42
Ignition Type $U_m = 60 \text{ V}$	II 2G EEx ib IIC T4 $U_i = 15 \text{ V}$ $I_i = 30 \text{ mA}$ $P_i = 115 \text{ mW}$ effective internal capacitance: 11 nF effective internal capacitance to earth: 19.6 nF effective internal inductance: 0.14 mH
Ignition Type $U_m = 60 \text{ V}$	II 2G EEx nA [L] IIC T4 $U_B = 16-30 \text{ V}$ $I_B = 2-15 \text{ mA}$
Ignition Type $U_m = 60 \text{ V}$	II 2D T 85 °C ... T _{med} IP67 / $T_{amb} = -20 \text{ °C} \dots +60 \text{ °C}$

Recommended NAMUR Isolation Amplifiers for EEx ib	
ABB Automation	V17131-51 ... 53, V17131-54 ... 56
Digitable, MTL, Pepperl+Fuchs, etc.	Various types



Fluid Temperatures/Temperature Classes

For the supply circuit terminals 31, 32 and the contact output 41, 42 cables suitable for temperatures to $T = 110\text{ °C}$ can be used without limitations.

Category 2/3G:

For cables which are only suitable for temperatures to $T = 80\text{ °C}$, the shorting of the two circuits during a fault condition is to be considered, otherwise the reduced temperature ranges in the following table apply.

Category 2D:

For cables which are only suitable for temperatures to $T = 80\text{ °C}$, the reduced temperature ranges in the following table apply.

Ambient Temperature ²⁾ [°C]	Max. Temperature with the Connection Cable Used Terminals 31/32, 41/42 [°C]	Max. Allow. Fluid Temperature [°C]
(-55) -20 to 70	110	280/400 ¹⁾
(-55) -20 to 70	80	160
(-55) -20 to 60		240
(-55) -20 to 55		280
(-55) -20 to 50		320 ¹⁾
(-55) -20 to 40		400 ¹⁾

1) Fluid temperature $>280\text{ °C}$ only for Vortex-Flowmeter FV4000

2) Lower limits for the ambient temperature are a function of the approvals and the ordering temperature (standard -20 °C)

Maximum Fluid Temperature	Temperature Class
130 °C	T4
195 °C	T3
290 °C	T2
400 °C	T1

Insulating the Flowmeter

An insulation thickness up to 100 mm above the upper edge is permissible.

Use of Trace Heaters

Trace heaters may only be used if:

- they are rigidly attached to the pipeline
- they are installed within the insulation (max. thickness of 100 mm is not to be exceeded).
- the actual max. temperature of the trace heaters \leq than the max. fluid temperature.

The installation requirements per EN60079-14 are to be observed!

Assure that there are no interference effects due to the trace heaters on the EMC-Protection of the instrument, and that no additional vibrations are generated.

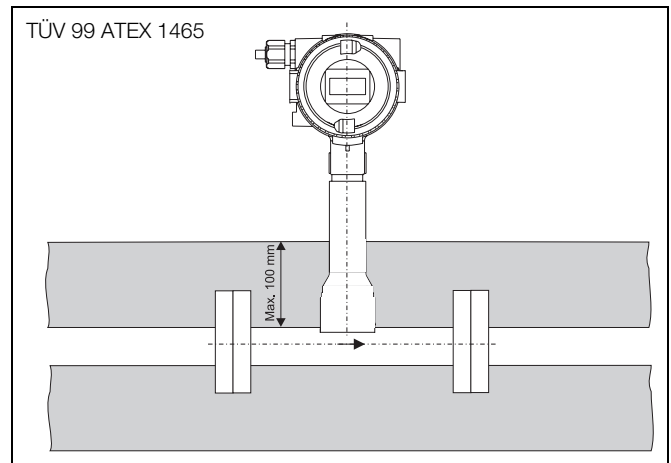

Fig. 32: Insulation of the Flowmeter

**Design EEx „d“/EEx „ib“ /EEx „n“
for VT42/ST42 and VR42/SR42 (4-20mA/HART)**



The housing covers must be completely closed for operation in explosive areas.

EC-Type Examination Certificate TÜV 00 ATEX 1521X

Identification:



Converter/Flowmeter Primary

II 2G EEx d [ib] IIC T6

II 2G EEx ib IIC T4

II 3G EEx nA [L] IIC T4

II 2D T 85 °C ... T_{med} IP67



Flowmeter Primary

II 2G EEx ib IIC T4

II 3G EEx nA [L] IIC T4

II 2D T 85 °C ... T_{med} IP67

Interconnections

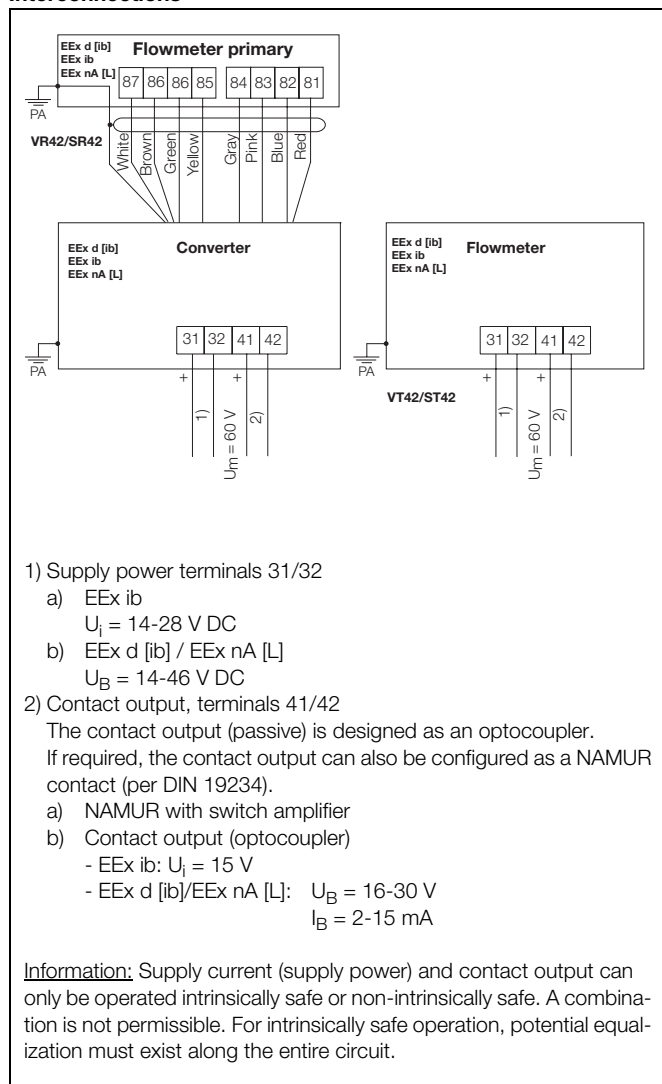
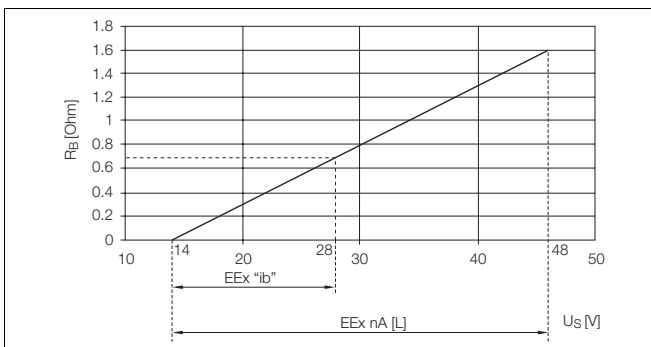

Fig. 33: Interconnection Diagram VT42/ST42 and VR42/SR42



**Terminals 31/32
Supply Power or Supply Current**



The minimum voltage U_S of 14 V is based on a load of 0 Ω

U_S = Supply voltage

R_B = Maximum allow. load in the supply circuit

e.g. indicator, recorder or line resistance

Ex-Approval Specifications VT42/ST42 / VR42/SR42

Supply Circuit	Terminals 31,32
Ignition Type $U_m = 60 \text{ V}$	II 2G EEx d [ib] IIC T6 II 3G EEx nA [L] IIC T4 $U_B = 14-46 \text{ V}$
Ignition Type $U_m = 60 \text{ V}$	II 2G EEx ib IIC T4 $U_i = 28 \text{ V}$ $I_i = 110 \text{ mA}$ $P_i = 770 \text{ mW}$ effective internal capacitance: 14.6 nF effective internal capacitance to earth: 24.4 nF effective internal inductance: 0.27 mH
Ignition Type $U_m = 60 \text{ V}$	II 2D T 85 °C ... T _{med} IP67/T _{amb} = -20 °C ... +60 °C

Recommended Transmitter Power Supplies for EEx ib	
ABB Automation	Contrans IV 17151-62
Digitable, MTL, Pepperl+Fuchs, etc.	Various types

Contact Output	Terminals 41, 42
Ignition Type $U_m = 60 \text{ V}$	II 2G EEx d [ib] IIC T6 II 3G EEx nA [L] IIC T4 $U_B = 16-30 \text{ V}$ $I_B = 2-15 \text{ mA}$
Ignition Type $U_m = 60 \text{ V}$	II 2G EEx ib IIC T4 $U_i = 15 \text{ V}$ $I_i = 30 \text{ mA}$ $P_i = 115 \text{ mW}$ effective internal capacitance: 11 nF effective internal capacitance to earth: 19.6 nF effective internal inductance: 0.14 mH
Ignition Type $U_m = 60 \text{ V}$	II 2D T 85 °C ... T _{med} IP67 / T _{amb} = -20 °C ... +60 °C

Recommended NAMUR Isolation Amplifiers for EEx ib	
ABB Automation	V17131-51 ... 53, V17131-54 ... 56
Digitable, MTL, Pepperl+Fuchs, etc.	Various types



The installation information per EN 60079-14 is to be observed. At start-up, the standard EN 50281-1-2 for use in areas with combustible dust must be considered.

After the power is turned off, a period of $t > 2$ minutes should elapse before the converter housing is opened.

Fluid Temperatures/Temperature Classes

For the supply circuit terminals 31, 32 and the contact output 41, 42 cables suitable for temperatures to $T = 110\text{ °C}$ can be used without limitations.

For cables which are only suitable for temperatures to $T = 80\text{ °C}$, the reduced temperature ranges in the following table apply.

Ambient Temperature ²⁾ [°C]	Max. Temperature with the Connection Cable Used Terminals 31/32, 41/42 [°C]	Max. Allow. Fluid Temperature [°C]
(-40) -20 to 60	110	280/400 ¹⁾
(-40) -20 to 60	80	240
(-40) -20 to 55		280
(-40) -20 to 50		320 ¹⁾
(-40) -20 to 40		400 ¹⁾

1) Fluid temperature $>280\text{ °C}$ only for Vortex-Flowmeter FV4000

2) Lower limits for the ambient temperature are a function of the approvals and the ordering temperature (standard -20 °C)

Ex-Design	Maximum Fluid Temperature	Temperature Class
EEx d [ib] IIC	80 °C	T6 ³⁾
	95 °C	T5 ³⁾
EEx ib IIC or EEx nA [L]	130 °C	T4
	195 °C	T3
	290 °C	T2
	400 °C	T1

3) Not available for flowmeter primary Versions VR42/SR42

Insulating the Flowmeter

An insulation thickness up to 100 mm above the upper edge is permissible.

Use of Trace Heaters

Trace heaters may only be used if:

- they are rigidly attached to the pipeline
- they are installed within the insulation (max. thickness of 100 mm is to be maintained).
- the actual max. temperature of the trace heaters \leq than the max. fluid temperature.

The installation requirements per EN60079-14 are to be maintained!

Assure that there are no interference effects due to the trace heaters on the EMC-Protection of the instrument, and that no additional vibrations are generated.

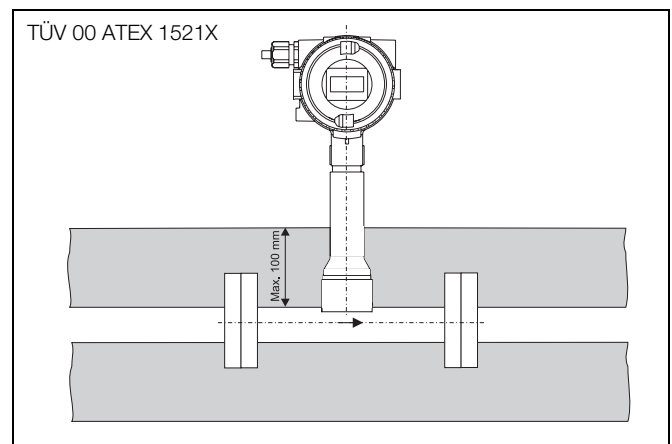

Fig. 34: Insulation of the Flowmeter



Design FM-Approval
for VT43/ST43 and VR43/SR43 (4-20mA/HART)
FM-Revision Report Project ID 3007647



The housing covers must be completely closed for operation in explosive areas.

Identification

Explosion Proof	XP/Class I/Div 1/BCD/T4 Ta = 70 °C Type 4X
Dust ignition proof	DIP/Class II,III/Div 1/EFG/T4 Ta = 70 °C Type 4X
intrinsically safe	IS/Class I, II,III/Div 1/ABCDEFG/T4 Ta = 70 °C Entity Type 4X
Non-incendive	NI/Class I/Div 2/ABCD/T4 Ta = 70 °C Type 4X
Suitable	S/Class II,III/Div 2/FG/T4 Ta = 70 °C Type 4X

Entity see: SD-50-2651 (Fig. 35) parameters: Vmax, Imax, Pi, Li, Ci
Enclosure: Type 4X

Terminals 31/32
Supply Power or Supply Current

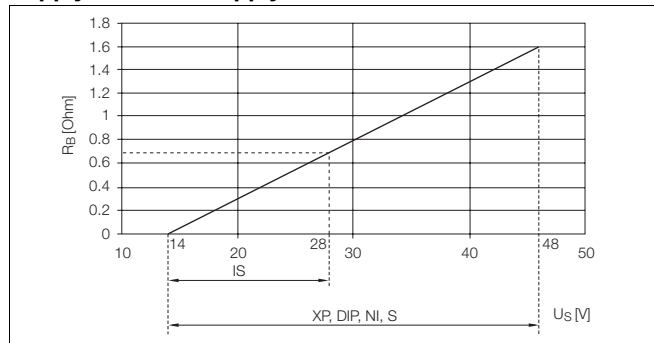

The minimum voltage U_S of 14 V is based on a load of 0Ω
 U_S = Supply voltage
 R_B = Maximum allow. load in the supply circuit
 e.g. indicator, recorder or line resistance

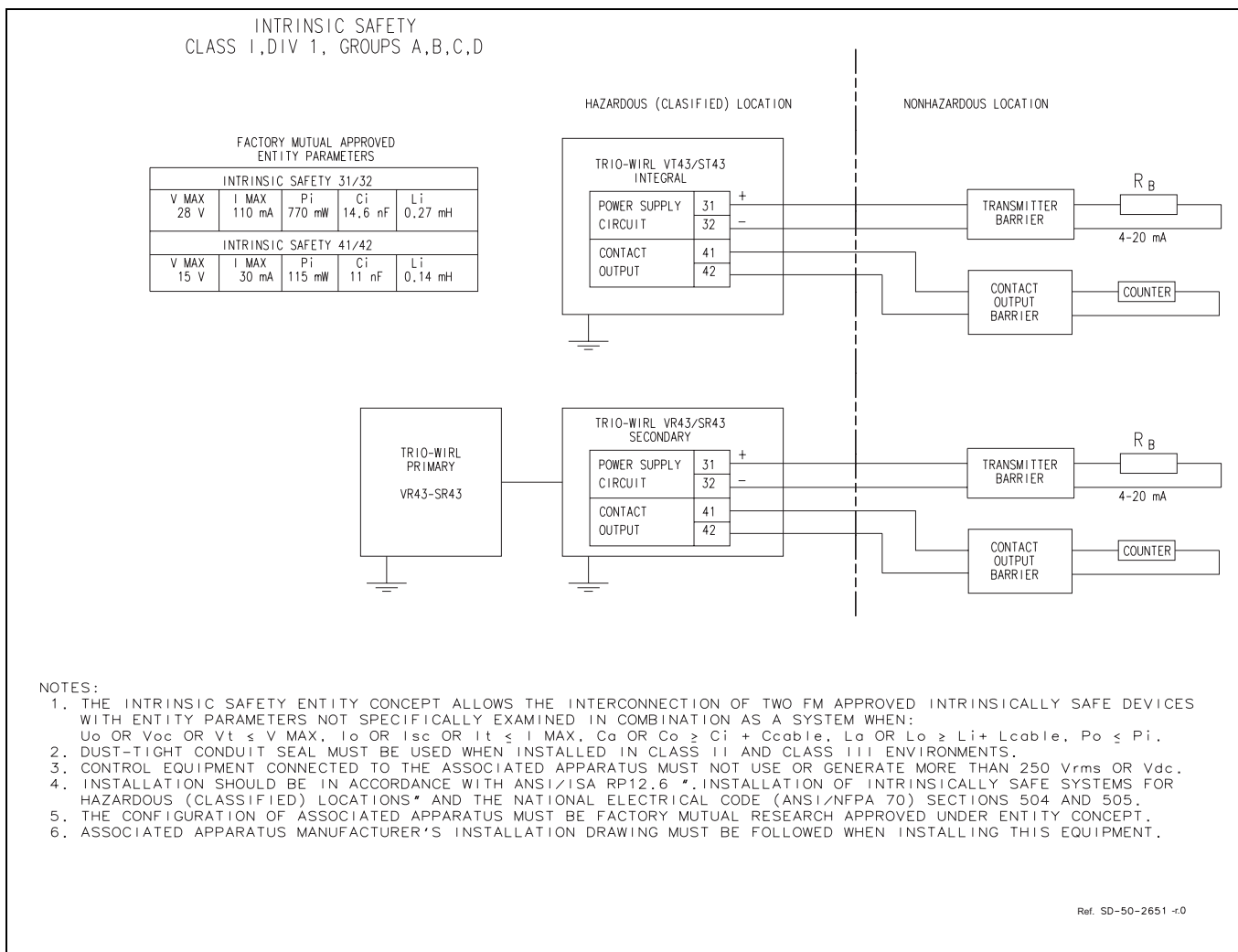

Fig. 35: Interconnection Diagram and Specifications VT/VR43 & ST/SR43

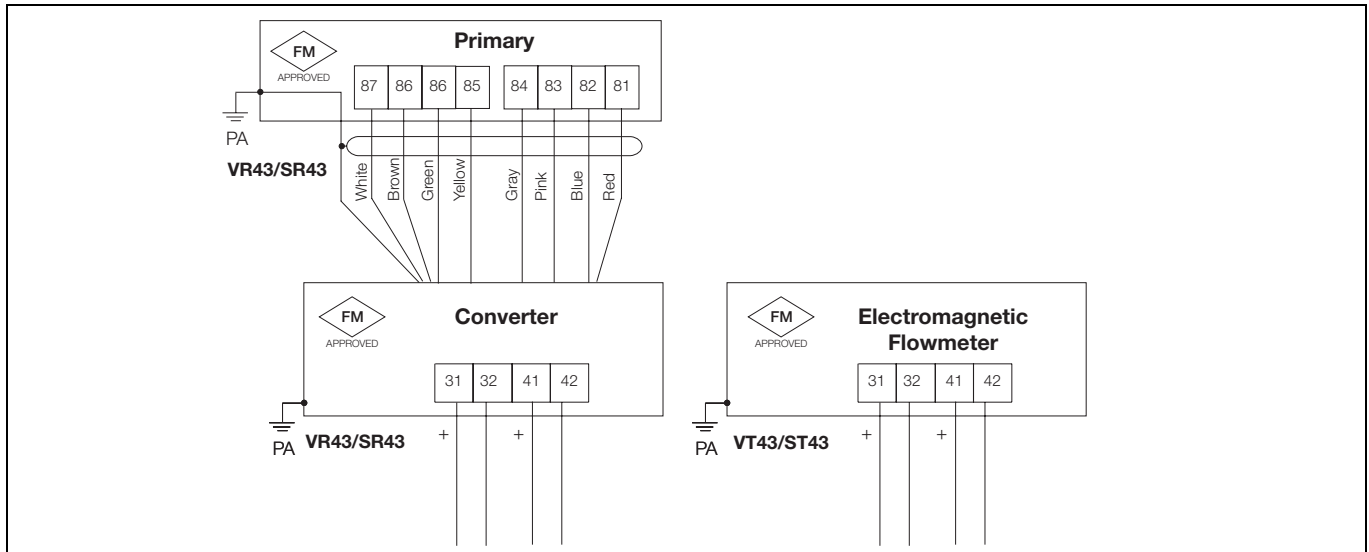

Fig. 36: Interconnection Diagram VR/SR43 & VT/ST43

Ex-Approval Specifications

VT43/ST43; VR43/SR43

Power Supply Circuit terminals 31, 32

Explosion Proof	XP/Class I/Div 1/BCD/T4 Ta = 70 °C Type 4X	$U_B = 14-46 V$
Dust ignition proof	DIP/Class II,III/Div 1/EFG/T4 Ta = 70 °C Type 4X	
intrinsically safe	IS/Class I, II,III/Div 1 ABCDEFG/T4 Ta = 70 °C Entity Type 4X	$V_{max} = 28 V$ $I_{max} = 110 mA$ $P_i = 770 mW$ effective internal capacitance: 14.6 nF effective internal capacitance to earth: 24.4 nF effective internal inductance: 0.27 mH
Non-incendive	NI/Class I/Div 2/ABCD/T4 Ta = 70 °C Type 4X	$U_B = 14-46 V$
Suitable	S/Class II,III/Div 2/FG/T4 Ta = 70 °C Type 4X	

VT43/ST43; VR43/SR43

Power Supply Circuit terminals 41, 42

Explosion Proof	XP/Class I/Div 1/BCD/T4 Ta = 70 °C Type 4X	$U_B = 16-30 V$ $I_B = 2-15 mA$
Dust ignition proof	DIP/Class II,III/Div 1/EFG/T4 Ta = 70 °C Type 4X	
intrinsically safe	IS/Class I, II,III/Div 1 ABCDEFG/T4 Ta = 70 °C Entity Type 4X	$V_{max} = 15 V$ $I_{max} = 30 mA$ $P_i = 115 mW$ effective internal capacitance: 11 nF effective internal capacitance to earth: 19.6 nF effective internal inductance: 0.14 mH
Non-incendive	NI/Class I/Div 2/ABCD/T4 Ta = 70 °C Type 4X	$U_B = 16-30 V$ $I_B = 2-15 mA$
Suitable	S/Class II,III/Div 2/FG/T4 Ta = 70 °C Type 4X	



Design EEx „ia“ for VT4A/ST4A and VR4A/SR4A (Fieldbus)



The housing covers must be completely closed for operation in explosive areas.

EC-Type Examination Certificate TÜV 00 ATEX 1771

Identification:



II 2G EEx ia IIC T4
II 2D T85 °C ... T_{med} IP67

The Ex-Design conforms to the FISCO-Model (FISCO = Fieldbus Intrinsically Safe Concept) defined by PTB.

Interconnections

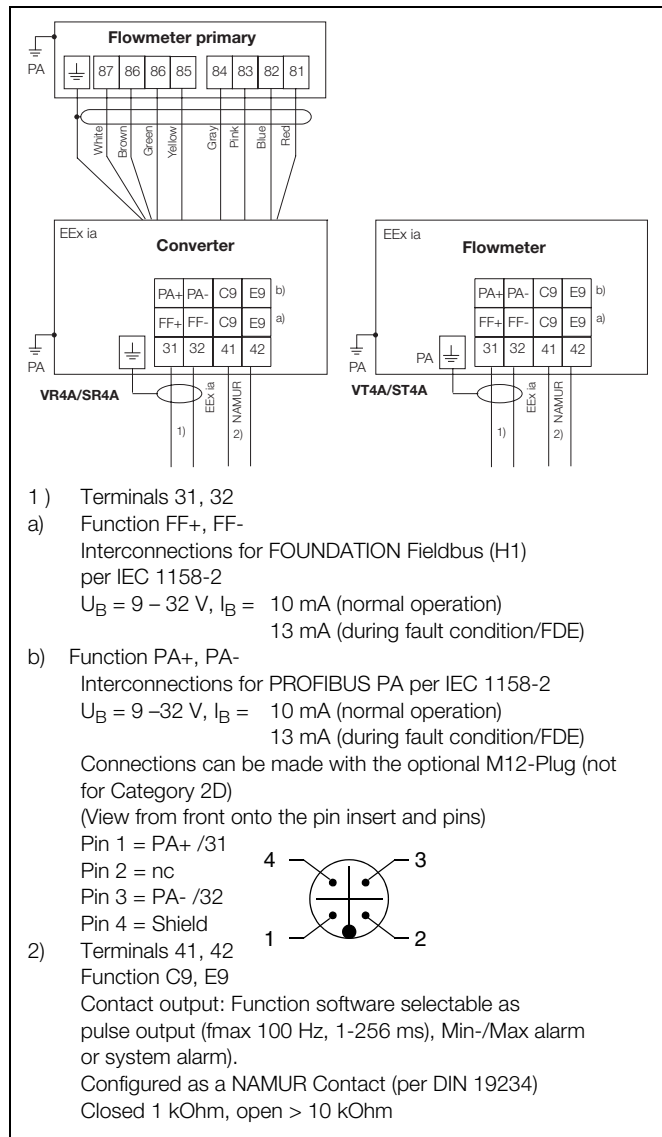

Fig. 37: Interconnection Diagram VT4A/ST4A and VR4A/SR4A



The installation information per EN 60079-14 is to be observed. At start-up, the standard EN 50281-1-2 for use in areas with combustible dust must be considered. After the power is turned off, a period of t > 2 minutes should elapse before the converter housing is opened.

Ex-Approval Specifications VT4A/ST4A / VR4A/SR4A

Supply Power Circuit	Terminals 31,32
Ignition Type	II 2G EEx ia IIC T4/T _{amb} = (-40 °C) -20 ... +70 °C U _i = 24 V I _i = 380 mA P _i = 9.12 W The effective internal capacitance and inductance are negligibly small.
Ignition Type	II 2D T 85 °C ... T _{med} IP67/T _{amb} = -20 °C ... +60 °C

Contact Output	Terminals 41, 42
Ignition Type	II 2G EEx ia IIC T4 U _i = 15 V I _i = 30 mA P _i = 115 mW effective internal capacitance: 3.6 nF effective internal capacitance to earth: 3.6 nF effective internal inductance: 0.14 mH
Ignition Type	II 2D T 85 °C ... T _{med} IP67 / T _{amb} = -20 °C ... +60 °C

Fluid Temperatures/Temperature Classes

For the supply circuit terminals 31, 32 and the contact output 41, 42 cables suitable for temperatures to T = 110 °C can be used without limitations.

Category 2/3G:

For cables which are only suitable for temperatures to T = 80 °C, the shorting of the two circuits during a fault condition is to be considered, otherwise the reduced temperature ranges in the following table apply.

Category 2D:

For cables which are only suitable for temperatures to T = 80 °C, the reduced temperature ranges in the following table apply.

Ambient Temperature ²⁾ [°C]	Max. Temperature with the Connection Cable Used Terminals 31/32, 41/42 [°C]	Max. Allow. Fluid Temperature [°C]
(-40) -20 to 70	110	280/400 ¹⁾
(-40) -20 to 70	80	160
(-40) -20 to 60		240
(-40) -20 to 55		280
(-40) -20 to 50		320 ¹⁾
(-40) -20 to 40		400 ¹⁾

1) Fluid temperatures >280 °C only for Vortex-Flowmeter FV4000
2) Lower limits for the ambient temperature are a function of the approvals and the ordering temperature (standard -20 °C)

Maximum Fluid Temperature	Temperature Classes
130 °C	T4
195 °C	T3
290 °C	T2
400 °C	T1

Insulating the Flowmeter

An insulation thickness up to 100 mm above the upper edge is permissible.

Use of Trace Heaters

Trace heaters may only be used if:

- they are rigidly attached to the pipeline
- they are installed within the insulation (max. thickness of 100 mm is to be maintained).
- the actual max. temperature of the trace heaters \leq than the max. fluid temperature.

The installation requirements per EN60079-14 are to be maintained!

Assure that there are no interference effects due to the trace heaters on the EMC-Protection of the instrument, and that no additional vibrations are generated.

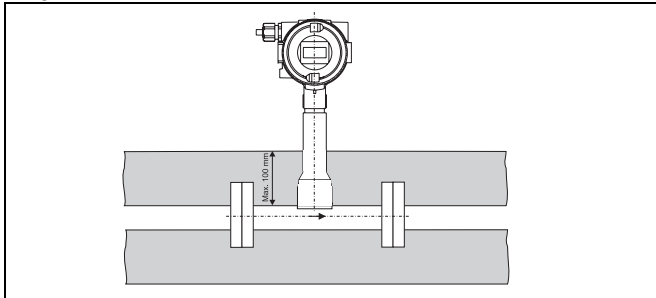

Fig. 38: Insulating the Flowmeter

Questionnaire Vortex-/Swirl Flowmeters

Customer:		Date:	
Mr./Mrs./Ms.:		Dep't:	
Telephone:		Telefax:	
Metering System			
<input type="checkbox"/> Vortex-Flowmeter FV4000 <input type="checkbox"/> Swirl-Flowmeter FS4000		<input type="checkbox"/> Integrated Pt100 (for fluid temperature measurements or saturated steam mass calculations)	
Fluid:			
Composition: <input type="checkbox"/> Oxygen		<input type="checkbox"/> Steam <input type="checkbox"/> Gas	<input type="checkbox"/> Liquid
Flowrate: (Min, max, operating point)		m ³ /h kg/h	<input type="checkbox"/> Normal <input type="checkbox"/> Mass <input type="checkbox"/> Actual
Density: (Min, max, operating point)		kg/m ³	<input type="checkbox"/> Normal <input type="checkbox"/> Actual
Viscosity: (please specify for liquids) (Min, max, operating point)		mPas	
Fluid Temperature: (Min, max, operating point)		°C	
Ambient Temperature: (Min, max, operating point)		°C	
Pressure: (Min, max, operating point)		bar	
Meter Size/Pressure Rating of the Pipeline:			
DN:		PN:	
Effective Inside Diameter of the Pipeline			
mm		inch	

Converter Design/ Communication:	<input type="checkbox"/> 4-20 mA (2-Wire) HART (Standard)	<input type="checkbox"/> 2-Wire PROFIBUS PA	<input type="checkbox"/> 2-Wire FOUNDATION Fieldbus
	Ex-Protection: <input type="checkbox"/> None <input type="checkbox"/> 2G EEx „ib“ <input type="checkbox"/> 2G EEx „d“ <input type="checkbox"/> 3G EEx „nA [L]“ <input type="checkbox"/> Class I DIV 1	Ex-Protection: <input type="checkbox"/> None <input type="checkbox"/> 2G EEx „ia“	Ex-Protection: <input type="checkbox"/> None <input type="checkbox"/> 2G EEx „ia“



The information in the Operating Instruction should be noted!

The IndustrialTM wordmark and all mentioned product names in the form XXXXXTM are registered or pending trademarks of ABB.

ABB has Sales & Customer Support expertise in over 100 countries worldwide.

www.abb.com

The Company's policy is one of continuous product improvement and the right is reserved to modify the information contained herein without notice.

Printed in the Fed. Rep. of Germany (09.2004)

© ABB 2004



ABB Ltd.
Oldends Lane, Stonehouse
Gloucestershire, GL 10 3TA
UK
Phone: +44(0)1453 826661
Fax: +44(0)1453 829671

ABB Inc.
125 E. County Line Road
Warminster, PA 18974
USA
Phone: +1 215 674 6000
Fax: +1 215 674 7183

ABB Automation Products GmbH
Dransfelder Str. 2
37079 Göttingen
GERMANY
Phone: +49 551 905-534
Fax: +49 551 905-555

CCC-support.deapr@de.abb.com