

# Head mounted Temperature Transmitter TF02/TF02-Ex

FOUNDATION Fieldbus H1,  
Pt 100 (RTD), thermocouples,  
1 or 2 independent channels

**IndustrialIT**  
enabled™

## ■ Input

- Resistance thermometer (2-, 3-, 4-wire circuit)
- Thermocouples
- Resistance remote signalling unit  
(0...500 Ω, 0...4000 Ω)
- Voltages, mV calibrator (-120...+1200 mV)

## ■ Input functionality

- 1 or 2 channels

## ■ Electrical isolation (I/O) between input and output

## ■ Digital, long-term solid processing of measuring values

## ■ Customer-specific linearization

## ■ Continuous sensor and self-monitoring

## ■ EMC acc. to EN 61326 and NAMUR recommendation NE 21

## ■ Parameterization via DD and CFF file

## ■ Output

- FOUNDATION Fieldbus H1 acc. to specification 1.4
- Certified with Interoperability Test Kit 4.1
- IT Campaign Number: IT 015000
- Bus design acc. to IEC 61158-2, 31.25 kbit/s

## ■ Reserve voltage protection and solid bus current limitation

## ■ Approvals for explosion protection

- intrinsically safe ATEX
- Suitable for connecting to systems according to:
  - Entity model
  - FISCO model



**ABB**

## Technical data

### Device type

Standard Basic Device

### Power supply (at transmitter terminals)

#### Supply voltage

$U_s = 9...32$  V DC

#### for explosion protection application

dependent on the Ex supply unit

#### Supply voltage, poling protected

### Current consumption

Operating (quiescent): 10.5 mA

Fault current limiting: 15 mA

## Output

### Interface/Protocol

FOUNDATION Fieldbus H1 IEC 61158-2 / FF-H1Version 1.4

31.25 kbit/s

FF Registration: IT015000 Interoperability Test Kit 4.1

### Function blocks

tested function blocks 2 x AI (s)

operating time: 25 ms

other function blocks 1 x RB (s)

1 x TB (c)

## Input

### Resistance

#### Resistance thermometer

n · Pt100 up to Pt1000 (IEC 751: n = 0.1; 0.5; 1; 2; 5; 10)

(JIS 1604: n = 0.1; 0.5; 1; 2; 10) (SAMA: n = 0.1; 0.5; 1)

Ni50, Ni100, Ni120, Ni1000, Cu10, Cu100

Resistance	Range	Accuracy
	0...500 Ω	2 mΩ
	0...4000 Ω	20 mΩ

### Max. line resistance ( $R_W$ ) per core

2-, 3-, 4-wire 5 Ω, 10 Ω, 50 Ω

### Measuring current

300 μA

### Sensor short-circuit

< 5 Ω

### Sensor break (temperature/resistance measurement, 2-, 3-, 4-wire)

Measuring range 0... 500 Ω > 520 Ω

Measuring range 0...4000 Ω > 4200 Ω

### Sensor wire break monitoring in accordance with NAMUR

Sensor wire break detection

3-wire resistance measurement > 35 Ω

4-wire resistance measurement > 3.7 kΩ

### Input filter

50/60 Hz

## Thermocouples/Voltages

### Types

B, C, D, E, J, K, L, N, R, S, T, U

### Voltages

Range Accuracy

-120 mV...+1200 mV 10 μV

- 75 mV...+ 75 mV 2 μV

### Sensor monitoring current

1 μA between the measuring cycles

### Sensor wire break monitoring in accordance with NAMUR

Thermocouple measurement > 5 kΩ

Voltage measurement > 5 kΩ

### Input filter

50/60 Hz

### Internal reference junction

Pt100, via software switchable (no jumper necessary)

Standard	Input element		Measuring range	
		Sensor		
IEC 584-1		Thermocouple type B	0...+1820 °C	(+ 32...+3308 °F)
		Thermocouple type E	-270...+1000 °C	(-454...+1832 °F)
		Thermocouple type J	-210...+1200 °C	(-346...+2192 °F)
		Thermocouple type K	-270...+1372 °C	(-454...+2502 °F)
		Thermocouple type R	- 50...+1768 °C	(- 58...+3215 °F)
		Thermocouple type S	- 50...+1768 °C	(- 58...+3215 °F)
		Thermocouple type T	-270...+ 400 °C	(-454...+ 752 °F)
		Thermocouple type N	-270...+1300 °C	(-454...+2372 °F)
W3, ASTME 998		Thermocouple type C	0...+2315 °C	(+ 32...+4200 °F)
		Thermocouple type D	0...+2315 °C	(+ 32...+4200 °F)
DIN 43710		Thermocouple type L	-200...+ 900 °C	(-328...+1652 °F)
		Thermocouple type U	-200...+ 600 °C	(-328...+1112 °F)
IEC 751; JIS; SAMA <sup>1)</sup> 2-, 3- and 4-wire		Resistance thermometer Pt100	-200...+ 850 °C	(-328...+1562 °F)
		Resistance thermometer Pt1000	-200...+ 850 °C	(-328...+1562 °F)
DIN 43760 2-, 3- and 4-wire (a = 0.00618)		Resistance thermometer Ni100	- 60...+ 250 °C	(- 76...+ 482 °F)
		Resistance thermometer Ni1000	- 60...+ 250 °C	(- 76...+ 482 °F)
Resistance, 2-, 3- and 4-wire		Ω	0...500 Ω / 0...4000 Ω	
Voltage		mV	-120 mV...+1200 mV - 75 mV...+ 75 mV	

<sup>1)</sup> IEC 751 a = 0.00385; JIS a = 0.003916; SAMA a = 0.003902

**General characteristics**

**Response time**

< 0.5 s

**Vibration resistance**

Vibration in operation 2 g acc. to DIN IEC 68T.2-6  
 Resistance to shock 2 g acc. to DIN IEC 68T.2-27

**Electrical isolation (I/O)**

1.5 kV AC

**Long-term stability**

≤ 0.1 % p. a. or 0.2 K p. a.

**Environment conditions**

**Ambient temperature range**

-40...+85 °C

**Transport and storage temperature**

-40...+100 °C

**Relative humidity**

< 100 % (100 % humidity with isolated terminals only)

**Condensation**

permitted

**Mechanical construction**

**Dimensions**

cf. dimensional drawing

**Weight**

61 g

**Housing material**

Polycarbonat

**Color (Epoxy)**

black (Non-Ex type), blue (Ex-type)

**Terminals, pluggable**

2.5 mm<sup>2</sup>, screw terminals (stainless steel screws)

**Electromagnetic compatibility (EMC)**

According to NAMUR NE 21 recommendation

With Pt100 sensor and thermocouple

Type of test	Degree	Standard
Burst to signal/ data lines	1 kV	EN 61000-4-4 EN 61326
Static discharge contact discharge to: contact plate terminals	8 kV 6 kV	EN 61000-4-2
radiated field 80 MHz...2 GHz	10 V/m	EN 61000-4-3
coupling 150 kHz - 80 MHz	10 V	EN 61000-4-6

**Influences**

**Influence of ambient temperature acc. to IEC 68-2-2**

Pt 100	± 0.025 K/10 K
resistance measurement 0...500 W	± 10 mΩ/10 K
0...4000 Ω	± 100 mΩ/10 K
Thermocouple e. g. type K	± 0.025 K/10 K
voltage measurement -120 mV...+1200 mV	± 150 μV/10 K
- 75 mV...+ 75 mV	± 10 μV/10 K

**Characteristics at rated conditions**

acc. to IEC 770 (related to 25 °C)

**Measuring error incl. characteristic deviation**

Pt 100	± 0.1 K
resistance measurement 0...500 Ω	± 40 mΩ
0...4000 Ω	± 320 mΩ
Thermocouple e. g. type K	± 0.25 K
voltage measurement -120 mV...+1200 mV	± 50 μV
- 75 mV...+ 75 mV	± 10 μV

Additional influence of Pt100 DIN IEC 751 Cl. B  
 the internal ref. junction

**Parameterization / structure**

Type of input (2 independent channels), measuring range, input filter, damping, alarm function, limit values, safing all data proof against mains failure

**Standard parameter (factory settings)**

**Channel 1**

Pt100, 4-wire circuit, 0...+100 °C  
 damping 0 s, unit °C



**Channel 2**

disabled

**Explosion protection**

**Intrinsically safe**

EC Certificate DMT 02 ATEX E 068 X  
 (Intrinsically safe Zone 0/1 and Mine)

<b>Zone 0/1</b>		II 1 G EEx ia IIC T6
<b>Zone 0</b>		T1...T5 Ambient temperature: -20...+60 °C T6 Ambient temperature: -20...+50 °C
<b>Zone 1</b>		T1...T4 Ambient temperature: -40...+85 °C T5 Ambient temperature: -40...+65 °C T6 Ambient temperature: -40...+50 °C
<b>Mine</b>		I M 1 EEx ia I Ambient temperature: -20...+60 °C

**Non sparking "nA" ATEX**

EC Certificate BVS 03 E 171 X

**Zone 2 (TF02-Ex N)**  II 3 G EEx nA [nL] IIC T6

T1...T4 Ambient temperature: -40...+85 °C  
 T5 Ambient temperature: -40...+65 °C  
 T6 Ambient temperature: -40...+50 °C

**Canadian Standards Association and Factory Mutual**

**Intrinsically Safe**

**FM** Class I Div. 1/Div. 2, Groups A, B, C, D T6  
 Class I Zone 0, AEx ia  
 or Zone 0, AEx ib IIC

**CSA** Class I Div. 1/Div. 2, Groups A, B, C, D T6

**Nonincendive**

**FM** Class I Div. 2, Groups A, B, C, D T6

**CSA** Class I Div. 2, Groups A, B, C, D T6

Supply circuit	Supply and communication circuit ia/ib IIC	Supply and communication circuit ia/ib IIB	Measuring circuit ia/ib
Max. voltage	$U_i \leq 24 \text{ V}$	$U_i \leq 24 \text{ V}$	$U_o = 5.5 \text{ V}$
Short-circuit current	$I_i = 360 \text{ mA}$	$I_i = 380 \text{ mA}$	$I_o < 25 \text{ mA}$
Max. power	$P_i = 2.52 \text{ W}$	$P_i = 5.32 \text{ W}$	$P_o < 35 \text{ mW}$
Internal inductance	$L_i \leq 10 \mu\text{H}$	$L_i \leq 10 \mu\text{H}$	neglectable
Internal capacitance	$C_i = 5 \text{ nF}$	$C_i = 5 \text{ nF}$	$C_i = 60 \text{ nF}$

**Suitable for connecting to systems according to**

- Entity model and
- FISCO model

**Block diagram**

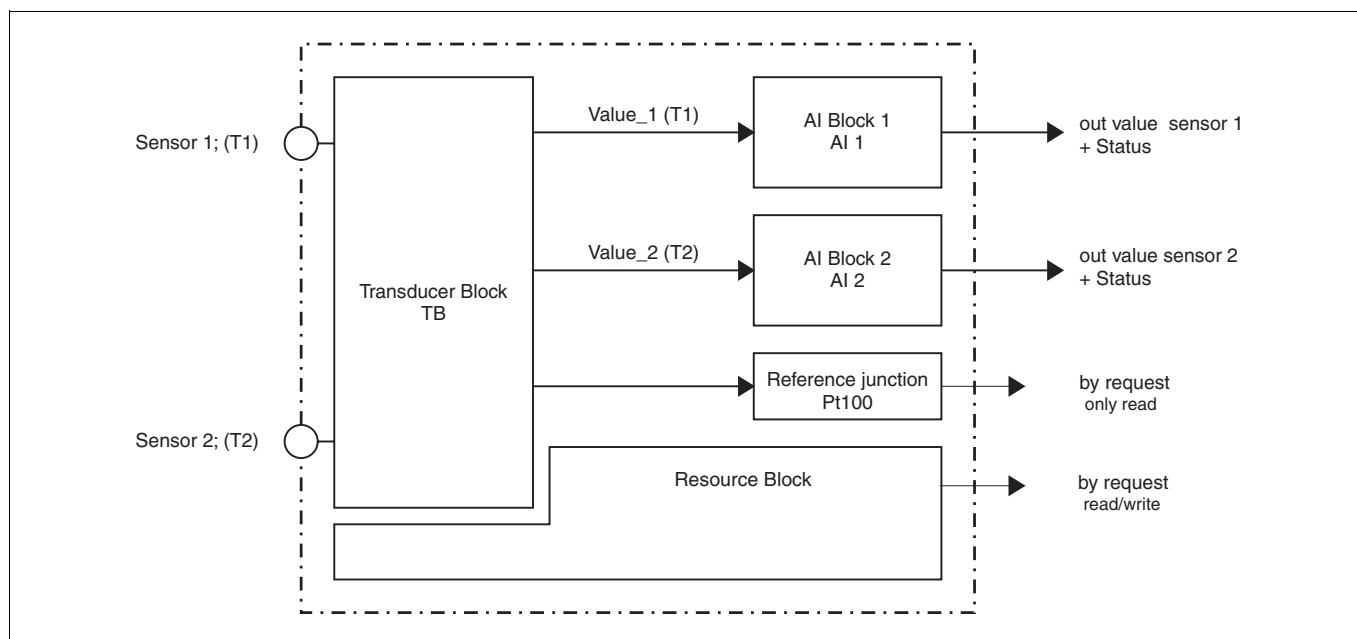

**Connection diagram**

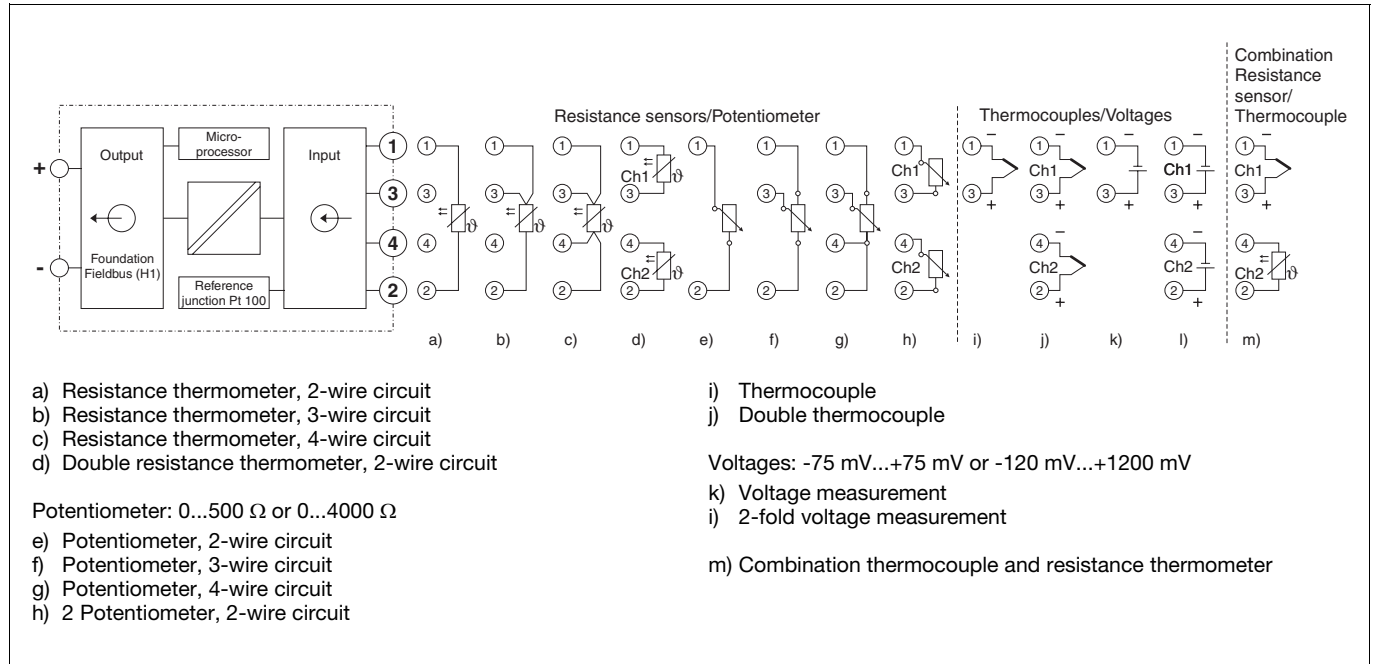

**Dimensional drawing** (dimensions in mm)

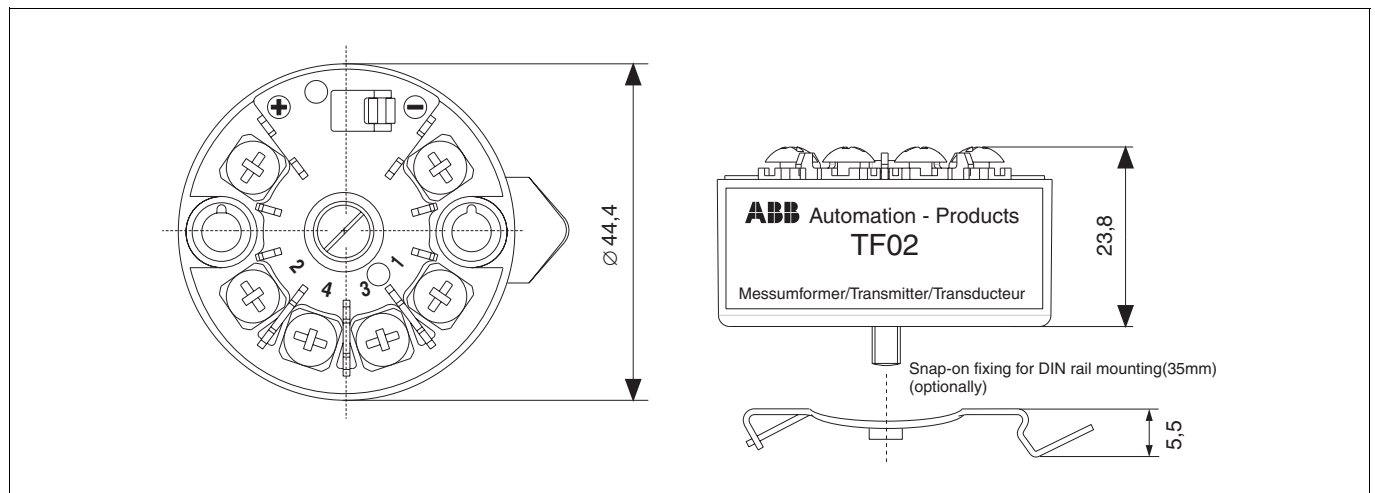

**Ordering information**

Head mounted Temperature Transmitter	Variant digit No.	1-7	8-9	10	11	12	13							
<b>TF02 / TF02-Ex</b>	Catalog No.	<b>V11527-</b>												
<b>Bus system</b> FOUNDATION Fieldbus (H1) acc. to Fieldbus standard IEC-61158-2; 31.25 kbit/s Standard Basic Device			FR											
<b>Explosion Protection</b> <b>TF02</b> without explosion protection <b>Type of protection: Non Sparking "nA" ATEX</b> <b>TF02-Ex N</b> DMT/ATEX <b>Zone 2:</b> II 3 G EEx nA [nL] IIC T6 <b>Type of protection: intrinsically safe ATEX</b> <b>TF02-Ex</b> DMT/ATEX <b>Zone 0:</b> II 1 G EEx ia IIC T6 (+ Mine: I M 1 EEx ia I) <b>Type of protection: intrinsically safe FM &amp; CSA</b> <b>TF02-Ex</b> FM <b>IS</b> Class I, Div. 1/Div. 2, Groups A, B, C, D T6, Class I, Zone 0, AEx ia oder AEx ib IIC (Class II Groups E, F, G; Class III if built in BUZH head or AGLH head) <b>nonincendive</b> , Class I, Div. 2, Groups A, B, C, D T6 (Class II Groups F, G; Class III if built in BUZH head or AGLH head) <b>TF02-Ex</b> CSA <b>IS</b> Class I, Div. 1 and Div. 2, Groups A, B, C, D T6 (Class II Groups E, F, G; Class III if built in BUZH head or AGLH head) <b>nonincendive</b> , Class I, Div. 2, Groups A, B, C, D T6 (Class II Groups F, G; Class III if built in BUZH head or AGLH head) <b>TF02-Ex</b> GOST <b>Zone 0:</b> 0 Ex ia IIC T6			1	N	5	7	9	R						
<b>Construction</b> Module Module with sensor connecting line Module with snap-on fixing Module with sensor connecting line, built into BUZH connection head BUSH connection head BUKH-Ex connection head AUZH connection head AUSH connection head AGLH connection head without display Attention: The sensor connecting lines correspond to the order for the type of sensor or its type of circuitry				3	1	4		R	P	N	V	U	X	
<b>Connections</b> no head selected with cable screw connection M20 x 1.5									0	M				
<b>Programming</b> Factory standard parameters Pt 100, 4-wire circuit, 1 channel, 0 ... 100°C, Damping off Customer specific parameter settings (all parameters except user curve)									0	1				
<b>Accessories</b>														
	Catalog No.													
TF02 / TF202 Simulation plug for bus system FOUNDATION Fieldbus		7957851												

1) protective pipe connection M24 x 1.5 (optional M20 x 1.5; 1/2" NPT; 3/4" NPT)

2) Standard: Aluminum, metal-cable-screw-connection

M20 x 1.5 EEx e (cable diameter 3.5 ... 8.7 mm)

(do not use for EEx d applications, see data sheet 10/10-3.28 EN for EEx d details)

---

The Industrial<sup>IT</sup> wordmark is a registered or pending trademark of ABB.

ABB has Sales & Customer Support expertise in over 100 countries worldwide.

[www.abb.com/instrumentation](http://www.abb.com/instrumentation)

The Company's policy is one of continuous product improvement and the right is reserved to modify the information contained herein without notice.

Printed in the Fed. Rep. of Germany (10.2006)

© ABB 2006



**ABB Ltd.**

Salterbeck Trading Estate  
Workington, Cumbria, CA14 5DS  
UK  
Tel: +44(0)1946-830-611  
Fax: +44(0)1946-832-661

**ABB Inc.**

125 E. County Line Road  
Warminster, PA 18974  
USA  
Tel: +1 215-674-6000  
Fax: +1 215-674-7183

**ABB Automation Products GmbH**

Borsigstr. 2  
63755 Alzenau  
Germany  
Tel: +49 551 905-534  
Fax: +49 551 905-555  
CCC-support.deapr@de.abb.com