

# Field mounted Temperature Transmitter TF212/TF212-Ex

PROFIBUS PA,  
Pt 100 (RTD), Thermocouples,  
1 or 2 independent channels

**IndustrialIT**  
enabled™

## ■ Input

- Resistance thermometer (2, 3, 4-wire circuit)
- Thermocouples
- Resistance remote signalling units  
(0...400 Ω, 0...4000 Ω)
- Voltages, mV (-15...+115 mV)

## ■ Output

- PROFIBUS PA profile V3.0, type A and B
- Bus design acc. to IEC 1158-2, 31.25 kbit/s

## ■ Electrical isolation (I/O)

## ■ Digital, long-term solid processing of measuring values

## ■ Customer-specific linearization

## ■ Continuous sensor and self-monitoring

## ■ Approvals for explosion protection

- Intrinsically safe  II 2 (1) G EEx ia IIC T6
- Flameproof ATEX
- Dust-explosionproof ATEX

## ■ Input functionality

- 1 or 2 channels
- Redundancy
- Average value
- Differential value

## ■ EMC acc. to EN 50082-2 and NE 21

## ■ Reserve voltage protection and solid bus current limitation

## ■ Parameterization

- DTM for FDT 0.98-1 and 1.2 interface and DSV4xx (SMART VISION)
- Siemens Simatic PDM driver for TF12/TF212



**PROFI**  
BUS

**Excellent long term stability  
Temperature linear output signal  
Enhanced self diagnostics**

**ABB**

## Technical data

### Output

#### Digital output signal

PROFIBUS PA profile V3.0, type A and B

#### Transmission rate (baud rate)

31.25 kbit/s

#### Nominal current consumption

11.8 mA

#### Max. current in case of device error

15 mA

#### Damping (programmable)

$t_{63} = 0...60$  s

### Input

#### Resistance (temperature linear)

#### Resistance thermometer

Pt 50...Pt 100...Pt 1000

#### Resistance

0...400  $\Omega$ /0...4000  $\Omega$

#### Maximum line resistance ( $R_{W\max}$ ) per core

< 5  $\Omega$

#### Measuring current

200  $\mu$ A

#### Sensor short-circuit

< 5  $\Omega$  (for RTD)

#### Sensor break

> 5 M $\Omega$

## Thermocouples

### Types

B, C, D, E, J, K, L, N, R, S, T, U

### Voltages

-15 mV...+ 115 mV

### Sensor monitoring current

200  $\mu$ A

### Input resistance

5 M $\Omega$

### Input filter

50/60 Hz

### Internal reference junction

Pt 100, programmable

Standard	Input element	Measuring range	Basis Measuring error
	Sensor		
IEC 584-1	Thermocouple type B	400...+1820 °C (+752...+3308 °F)	0.8 K
	Thermocouple type E	-100...+1000 °C (-148...+1832 °F)	0.2 K
	Thermocouple type J	-100...+1200 °C (-148...+2192 °F)	0.2 K
	Thermocouple type K	-180...+1370 °C (-292...+2498 °F)	0.2 K
	Thermocouple type R	- 50...+1760 °C (- 58...+3200 °F)	0.8 K
	Thermocouple type S	- 50...+1760 °C (- 58...+3200 °F)	0.8 K
	Thermocouple type T	-200...+ 400 °C (-328...+ 752 °F)	0.2 K
	Thermocouple type N	-180...+1300 °C (-292...+2372 °F)	0.2 K
W3, ASTM E 998	Thermocouple type C	0...+2300 °C (+ 32...+4172 °F)	0.8 K
	Thermocouple type D	0...+2300 °C (+ 32...+4172 °F)	0.8 K
DIN 43710	Thermocouple type L	-100...+ 900 °C (-148...+1652 °F)	0.2 K
	Thermocouple type U	-200...+ 600 °C (-328...+1112 °F)	0.2 K
IEC 751 <sup>1)</sup>	Resistance thermometer Pt 100	-200...+ 850 °C (-328...+1562 °F)	0.4 K
	Resistance thermometer Pt 1000	-200...+ 850 °C (-328...+1562 °F)	0.4 K
	Resistance thermometer Pt 100/PT1000	-100...+ 250 °C (-148...+ 482 °F)	0.2 K
DIN 43760 <sup>2)</sup>	Resistance thermometer Ni 100	- 60...+ 250 °C (- 76...+ 482 °F)	0.2 K
Resistance	2-, 3-, 4-wire	0...400 $\Omega$ /0...4000 $\Omega$	0.05 $\Omega$ /0.4 $\Omega$
Voltage		-15 mV...+115 mV	20 $\mu$ V

<sup>1)</sup> a = 0.00385

<sup>2)</sup> a = 0.00618

**Power supply** (at transmitter terminals)

**Supply voltage (poling protected)**

Non-Ex-application  $U_s = 9...32$  V DC  
For Ex-Application, max.  $U_i = 9...17.5$  V DC

**General characteristics**

**Rise time**

< 0.1...1.25 s

**Vibration resistance**

Vibration in operation 2g nach DIN IEC 68T.2-6

**Electrical isolation (I/O)**

1.5 kV

**Environment conditions**

**Ambient temperature range**

-40...+85 °C

**Transport and storage temperature**

-40...+100 °C

**Relative humidity**

< 100 % (100 % humidity with isolated terminals only)

**Condensation**

Permitted

**Influences**

**Influence of ambient temperature** (related to 25 °C)

Pt 100  $\pm 20$  ppm/K related to 1050 °C  
Thermocouple  $\pm 40$  ppm/K related to the defined thermocouple measuring range (IEC 584)

**Characteristics at rated conditions**

acc. to IEC 770, related to 25 °C)

**Measuring error incl. characteristic deviation**

Pt 100 (within range -100...+250 °C)  $\pm 0.2$  K  
resistance measurement 0...400  $\Omega$   $\pm 0.05$   $\Omega$   
0...4000  $\Omega$   $\pm 0.4$   $\Omega$

Thermocouple e. g. type K  $\pm 0.2$  K  
voltage measurement -15...+115 mV  $\pm 20$   $\mu$ V

**Additional influence of the internal reference junction**

Pt 100 DIN IEC 751 cl. B

**Mechanical construction**

**Housing material**

aluminium / stainless steel

**Color (EPOXY)**

light grey (RAL 9002)

**Weight**

1.250 g (without accessories)

**Electrical connection**

**Thread**

M20 x 1.5  
1/2" NPT, 3/4" NPT, 1/2" GK

**Cable glands (cable  $\varnothing$  3,5...8,7 mm)**

see ordering information

**Ground screw ext./int.**

6 mm<sup>2</sup> M5 / 2.5 mm<sup>2</sup> M4

**Terminals**

2.5 mm<sup>2</sup>, screw terminals

## Explosion protection

### Intrinsically safe (ATEX)

Marking Ⓔ II 2 (1) G EEx ia IIC T6  
 EC-Type-Examination certificate ZELM 99 ATEX 0021  
 Temperature class T6/T4 < 60 °C/85 °C

**Suitable for connecting to fieldbus systems according to**  
 – FISCO model

Supply circuit	Output [ia]	Input [ia]
Max. voltage	$U_i = 17.5 \text{ V}$	$U_o = 5.9 \text{ V}$
Short-circuit current	$I_i = 360 \text{ mA}$	$I_o = 17 \text{ mA}$
Max. power	$P_i < 2.52 \text{ W}$	$P_o < 26 \text{ mW}$
Internal inductance	$L_i < 10 \mu\text{H}$	neglectable
Internal capacitance	$C_i = 1.2 \text{ nF}$	neglectable

### Flameproof (ATEX)

Marking Ⓔ II 2 G EEx d IIC T6  
 Temperature class T6/T5/T4 <50 °C/65 °C/85 °C  
 EC-Type-Examination certificate PTB 99 ATEX 1144 X

### Dust-explosionproof (ATEX)

#### Zone 20: Intrinsically safe type

Marking Ⓔ II 1 D IP 65 T 135 °C  
Ⓔ II 2 G EEx ia IIC T6  
 EC-Type-Examination certificate DMT 02 ATEX E248 and  
Zelm 99 ATEX 0021

#### Zone 20: Non intrinsically safe type

Marking Ⓔ II 1 D IP 65 T 135 °C  
 EC-Type-Examination certificate DMT 02 ATEX E248

## Electromagnetic compatibility (EMC)

Acc. to NAMUR NE 21 recommendation.

With Pt 100 sensor

Type of test	Degree	Standard
Burst to signal/ data lines	1 kV	EN 61000-4-4 EN 50082-2
Static discharge contact discharge to: contact plate terminals for supply	8 kV 6 kV	EN 61000-4-2
Radiated field 80 MHz...1 GHz	10 V/m	EN 61000-4-3
Coupling 150 kHz - 80 MHz	10 V	EN 61000-4-6

## Parameterization/structure

Type of inputs (2 independent channels), measuring range, input filter, damping, alarm function, limit values, compensation for ageing, saving of all data proof against mains failure.

## Standard parameters (factory setting)

### Channel 1

Pt 100, 3-wire circuit  
 L-L/L/H/H-H-Lim = -200 °C/-200 °C/850 °C/850 °C  
 Damping 0 s, dimension °C

### Channel 2

Pt 100, 3-wire circuit  
 L-L/L/H/H-H-Lim = -200 °C/-200 °C/850 °C/850 °C  
 Damping 0 s, dimension °C

### Default address

126

## Process Control System (PCS)

A cyclic communication can be established with all PROFIBUS compatible PCSs. Acyclic communication requires a Master CI. 2, the communication may be established on the basis of the generic slave (to be in acc. to Profile 3.0; only standard parameters) or a TF 12 specific driver.

Those drivers are available for following PCSs:

- Freelance 2000/Control Builder F (DTM or template)
- Symphony (Composer via DTM)
- Siemens (via PDM)

## Configuration-tools

- DTM for FDT 0.98-1 and 1.2 interface and DSV4xx (SMART VISION)
- Siemens Simatic PDM driver for TF12/TF212

### Block diagram

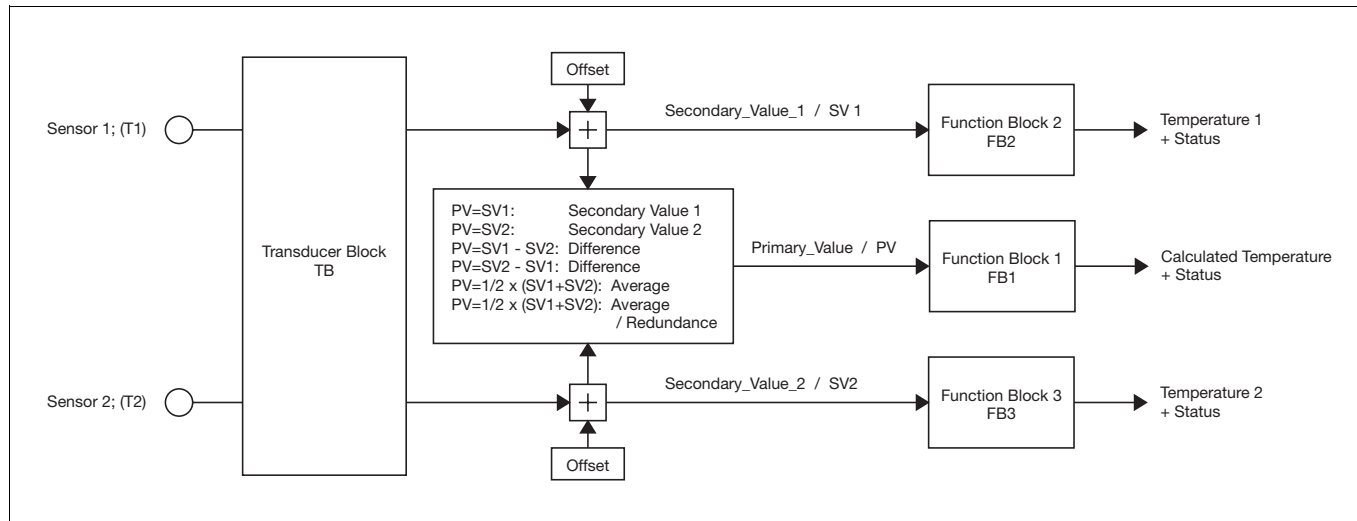

### Connection diagram

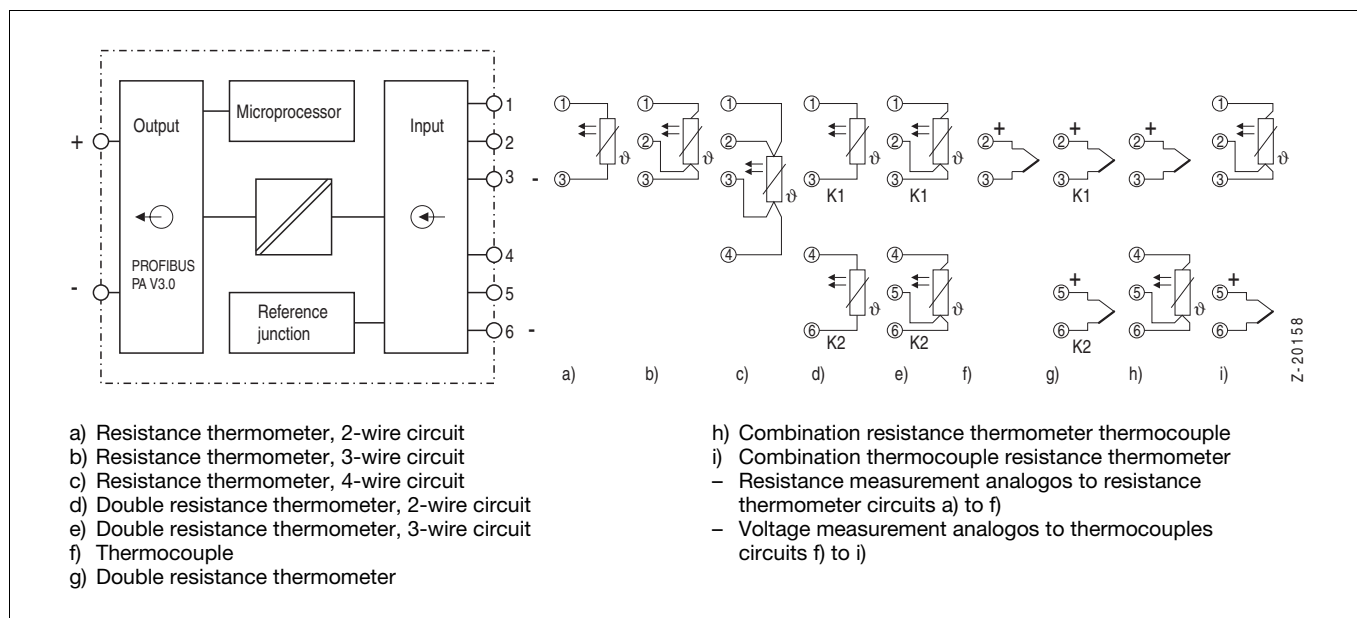

**Communication/Parameterization**

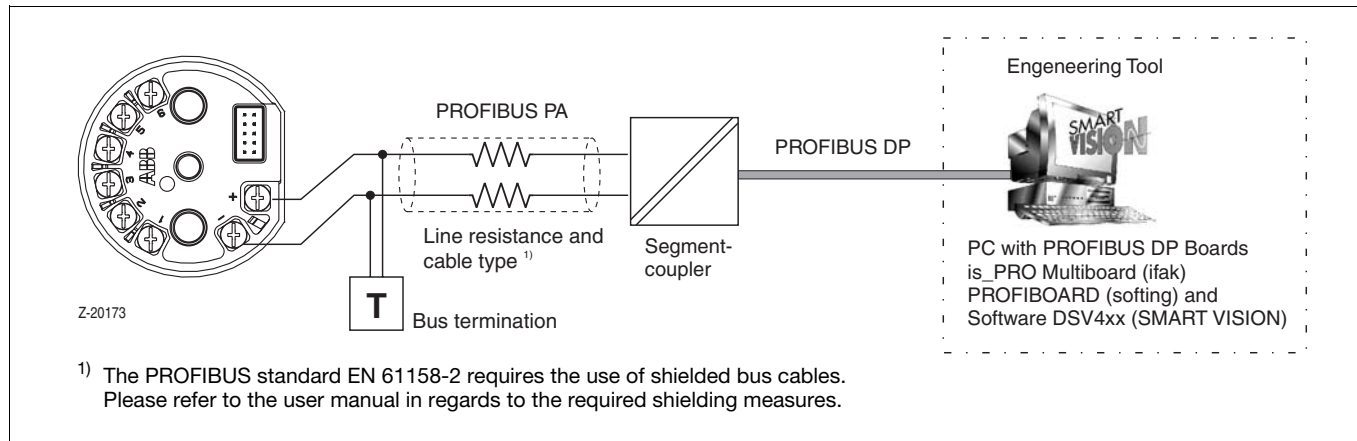

**Dimensional diagram** (dimensions in mm)

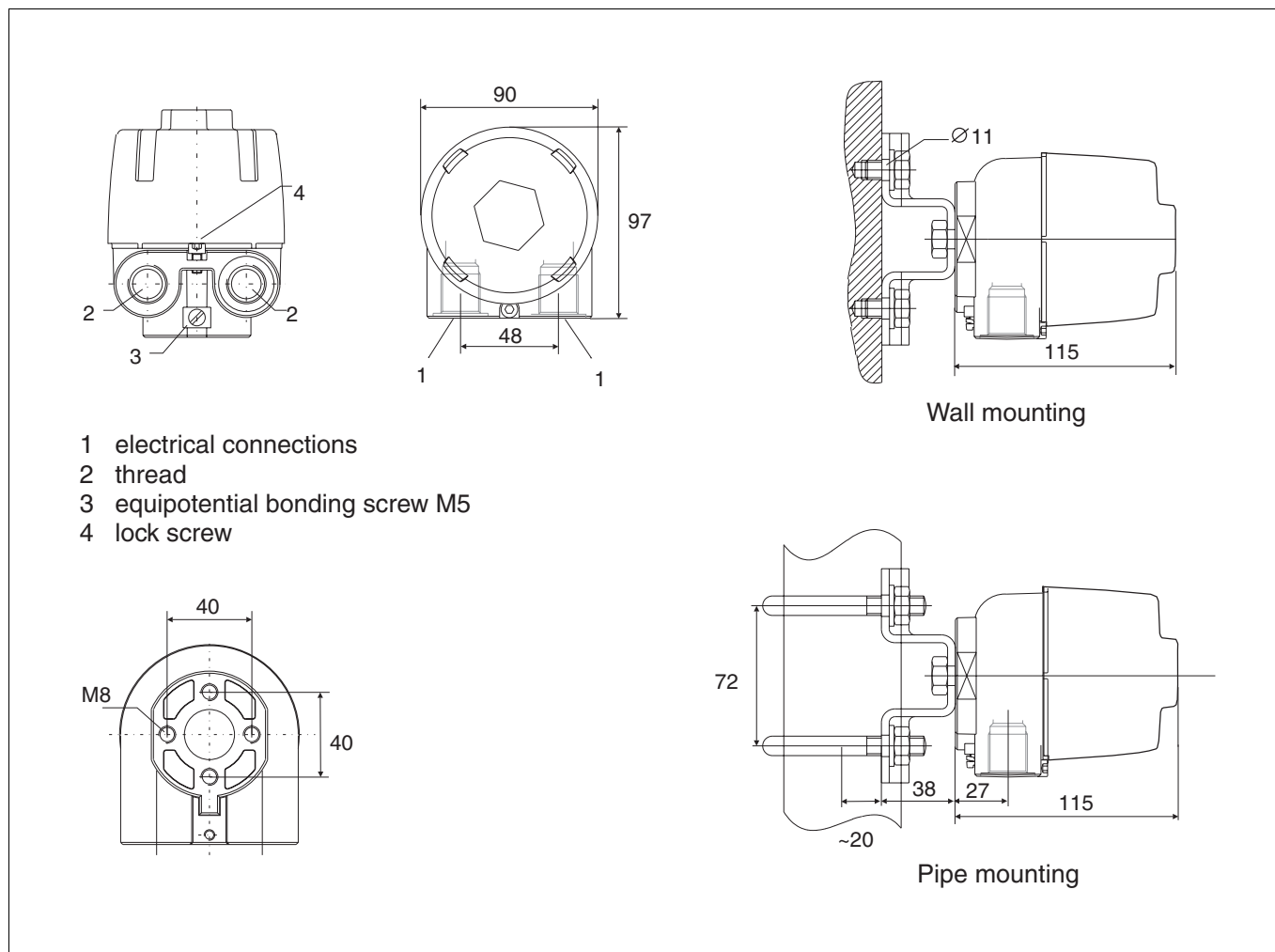

**Ordering information**

		Catalog No.						
<b>TF212/TF212-Ex</b>		<b>V11524-</b>						
<b>Without explosion protection</b>								
<b>TF212</b>	without explosion protection	1						
<b>With explosion protection</b>								
<b>Type of protection: intrinsic safety</b>								
<b>TF212-Ex</b>	Zelm / ATEX II 2 (1) G EEx ia IIC T6 (Zone 1)	5						
<b>Type of protection: flameproof</b>								
<b>TF212-Ex d</b>	PTB / ATEX II 2 G EEx d IIC T6 (Zone 20)	D						
<b>Type of protection: dust-explosionproof ATEX</b>								
<b>TF212-Ex</b>	DMT/ATEX II 1 D IP 65 T 135 °C and II 2 G EEx ia IIC T6 (intrinsically safe type)	S						
<b>TF212-Ex D</b>	DMT/ATEX II 1 D IP 65 T 135 °C (Non intrinsically safe type)	G						
<b>Display / construction</b>								
AGLF/AGSF housing without display		N						
<b>Material</b>								
Aluminum			A					
Stainless steel			E					
<b>Connections</b>								
with cable screw connections / PA-connector								
2 pieces: M20 x 1.5 or pressure-proof		1)	N					
M-connector for PROFIBUS PA (Weidmüller) and M 20 x 1.5			W					
Thread (without cable-screw-connection)								
M20 x 1.5			1					
1/2" NPT			2					
3/4" NPT			3					
1/2" GK			4					
<b>Mounting field housing</b>								
without			1					
Wall mounting (carbon steel)			2					
Wall mounting (stainless steel)			3					
2" Pipe mounting (carbon steel)			4					
2" Pipe mounting (stainless steel)			5					
<b>Programming</b>								
Factory standard parameter default address 126						S		
Channel 1: Pt100, 3-wire circuit, damping off, unit °C								
L-L // L / H // H-H = -200 °C // -200 °C / 850 °C // 850 °C								
Channel 2: Pt100, 3-wire circuit, damping off, unit °C								
L-L // L / H // H-H = -200 °C // -200 °C / 850 °C // 850 °C								
Customer-specified parameter definition (all parameter without user curve)						K		
Extended customer-specified parameter definition (all parameter including user curve)						L		

1) Metal screw connection EEx e or EEx d (cable-diameter 3.5...8.7 mm)

## Accessories

	Catalog No.		
Surge / Lightning protection for M20 x 1.5 cable -entry-glands, Non Ex-Version Type DPI MD 24 M 2 S	7964116		
Surge / Lightning protection for M20 x 1.5 cable -entry-glands, Ex-Version Type DPI MD EX 24 M 2	7964115		
Device Management Tool DSV4xx (SMART VISION) and DTM TF12/TF212	see Data Sheet 10/63-1.20 EN		
TF12/TF212 Siemens Simatic PDM 5.02 + SP1 device driver can be downloaded free of license costs from <a href="http://www.abb.com/instrumentation">http://www.abb.com/instrumentation</a>			

### Note:

**Surge/lightning protection is permitted only for ATEX intrinsically safe devices which will be installed in zone 1 or 2. Measuring circuit of these devices with surge/lightning protection can also be used for zone 0 if allowed in the ATEX approval of this device type**

The Industrial<sup>IT</sup> wordmark is a registered or pending trademark of ABB.

ABB has Sales & Customer Support expertise in over 100 countries worldwide.

[www.abb.com/instrumentation](http://www.abb.com/instrumentation)

The Company's policy is one of continuous product improvement and the right is reserved to modify the information contained herein without notice.

Printed in the Fed. Rep. of Germany (09.05)

© ABB 2005



#### ABB Ltd.

Salterbeck Trading Estate  
Workington, Cumbria, CA14 5DS  
UK  
Tel: +44(0)1946-830-611  
Fax: +44(0)1946-832-661

#### ABB Inc.

125 E. County Line Road  
Warminster, PA 18974  
USA  
Tel: +1 215-674-6000  
Fax: +1 215-674-7183

#### ABB Automation Products GmbH

Borsigstr. 2  
63755 Alzenau  
Germany  
Tel: +49 551 905-534  
Fax: +49 551 905-555  
CCC-support.deapr@de.abb.com