

for heavy duty applications / rough environmental conditions

## ■ Modular system

- Measuring inset, thermowell, extension tube, connection head, transmitter
- Supports numerous configurations

## ■ Exchangeable measuring inset

- Measuring elements can be exchanged during operation
- Secure base contact via pressure springs

## ■ Extremely robust connection head

- Low-copper aluminum, epoxy-coated
- Stainless steel for offshore applications

## ■ Approvals

- TÜV SIL 2 acc. to IEC 61508
- ATEX Ex i
- ATEX Dust-ignition proof
- ATEX Ex d
- GOST Russia
- GOST Kazakhstan
- GOST Ukraine

## ■ Transmitter in connection head

- Less wiring expense
- High measuring accuracy
- High interference resistance
- Interface to all state-of-the-art process management systems
- Process safety via SIL2 classification

## ■ Areas of application

- Offshore and coastal areas
- Petroleum and natural gas production and transport
- Petrochemical industry
- Chemical industry
- Energy industry
- Manufacturing systems and plant engineering



Highly sensitive under harsh conditions  
Sturdy and versatile  
All purpose

## Contents

<b>1</b>	<b>Overview of temperature sensors with an exchangeable measuring inset</b>	<b>3</b>
<b>2</b>	<b>Overview of measuring insets</b>	<b>4</b>
<b>3</b>	<b>General information</b>	<b>5</b>
3.1	Ambient temperature at connection head	5
3.2	Maximum process temperature	5
3.3	Pressure and vibration resistance of thermowell	5
3.4	Measuring range of measuring inset	7
3.5	Accuracy of measuring element	7
3.6	Measurement accuracy of mounted transmitter	8
3.7	Vibration resistance of measuring inset	8
3.8	Insulation resistance of measuring inset	8
3.9	Response times	9
3.10	Self-heating	9
3.11	Installation instructions	9
<b>4</b>	<b>Connection heads</b>	<b>10</b>
<b>5</b>	<b>Extension tubes</b>	<b>11</b>
5.1	Extension tube models	11
<b>6</b>	<b>Process connections</b>	<b>12</b>
6.1	SensyTemp TSP321 temperature sensor	12
6.2	SensyTemp TSP331 temperature sensor	12
<b>7</b>	<b>Thermowells</b>	<b>13</b>
7.1	Tubular thermowells	13
7.2	Drilled thermowells	15
<b>8</b>	<b>Transmitter</b>	<b>17</b>
<b>9</b>	<b>On-site display</b>	<b>17</b>
<b>10</b>	<b>Functional safety (SIL)</b>	<b>17</b>
<b>11</b>	<b>Approvals</b>	<b>17</b>
<b>12</b>	<b>Tests and certificates</b>	<b>18</b>
<b>13</b>	<b>Additional information</b>	<b>18</b>
13.1	Delivery times	18
13.2	Supplementary documents	18
13.3	Information about ordering information	18
<b>14</b>	<b>Ordering information</b>	<b>19</b>
14.1	SensyTemp TSP311	19
14.2	SensyTemp TSP321	24
14.3	SensyTemp TSP331	30

## 1 Overview of temperature sensors with an exchangeable measuring inset

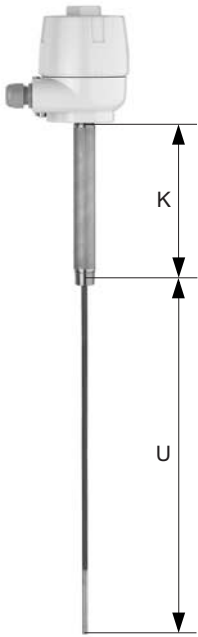
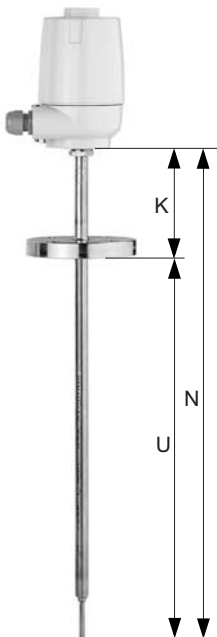
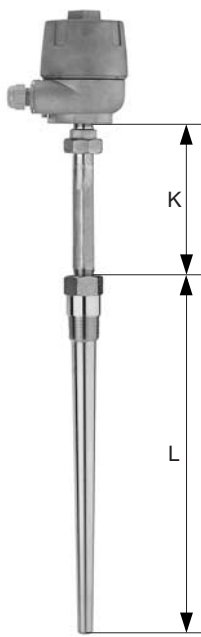
Model	TSP311	TSP321	TSP331
			
Thermowell properties	No thermowell, for installation in existing thermowell	Tube, tube base and welded process connection	Drilled bar stock material
Components	Measuring inset, extension tube with thermowell interface, connection head, transmitter, display	Measuring inset, thermowell with process connection, connection head, transmitter, display	Measuring inset, thermowell with process connection, extension tube, connection head, transmitter, display
Standard process connection	Installation by customer in existing thermowell	Screw-in thread, flange, compression fitting	Welded connections, screw-in thread, flange
Thermowell Ø (shaft/tip) [mm]	At installation site	12; 14; 12/6; 12/9; 14/6; 13,7; 13,7/6	17/13,5; 18/9; 24/12,5; 20/13,5; 23/13,5; 25/16; 32/13,5
Standard thermowell material	-	1.4404 (SS 316L) 1.4571 (SS 316Ti) 2.4819 (Hastelloy C276)	1.4571, 1.4404, 1.7335, 1.5415, 2.4819 (Hastelloy C276)
Standard ext. tube material	Stainless steel	One-piece thermowell	Stainless steel
Connection heads	AGL, AGLH, AGLD: Aluminum copper-free (< 0.04% Cu), epoxy-coated AGS, AGSH, AGSD: Stainless steel		
Output signal	Sensor signal, 4 to 20 mA, HART, PROFIBUS PA, FOUNDATION Fieldbus		
Measuring insets	Compliant with DIN 43735, exchangeable		
Explosion protection class	ATEX II 1 G EEx ia IIC T6 to T1 – zone 0, 1, 2 / connection head zone 1 ATEX II 1 D T133 □c T400 – Zone 20, 21, 22 ATEX II 1/2 G EEx d IIC T6 ... T4 – zone 1, 2 Note: Requirements for NAMUR NE24 recommendation are fulfilled by ATEX EEx i.		
Functional safety	SIL Level 2 acc. to IEC 61508, TÜV-certified		
Application	Comply with temperature limit for thermowell when measuring temperatures in tanks and pipelines in liquid and gaseous media.		
Temperature	Resistance thermometer < 600 °C, thermocouples < 1000 °C		
Pressure (depends on material, connection and stress data)	-	approx. 40 to 100 bar	approx. 700 bar
Weight for standard designs	1,0 ...3,0 kg	1,5 ...5,0 kg	1,5 ...7,0 kg

## 2 Overview of measuring insets

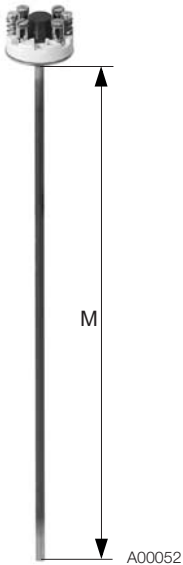
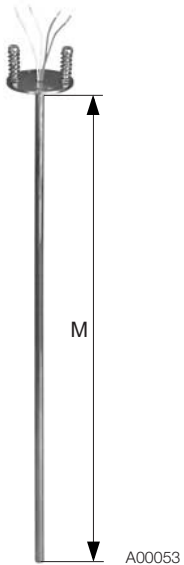
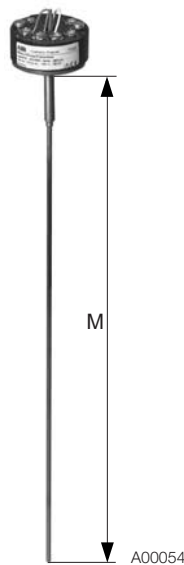
Type	Sheathed thermocouples and sheathed resistance thermometers		
			
Electrical connection	Terminal block	Flying leads	Installed ABB transmitter
Design	Mineral insulated cable: flexible, bendable, vibration resistant		
Measuring inset diameter	TSP311: Ø = 1 mm less than inside diameter of the thermowell		TSP321 / TSP331: Ø is adapted in factory to inside diameter of thermowell
Measuring inset length (M)	TSP311: Insertion length U + ext. tube length K + 40 mm TSP321: Nominal length N + 40 mm TSP331: Thermowell length L + ext. tube length K + 40 mm		
Standard sheath material	Resistance thermometers: 1.4571 (SS 316Ti) Thermocouples: 2.4816 (Inconel 600)		
Standard measuring elements	Resistance thermometers: Pt100 basic application (-50 ... 400 °C), single/dual, 3-/4-wire connection (EN 60751) Pt100 extended measuring range (-200 ... 600 °C), single/dual, 3-/4-wire connection Thermocouples: Type K, J and N, single/dual (EN 60584)		
Explosion protection class	ATEX II 1 G EEx ia IIC T6 ... T1 ATEX II 1 D T133 ... T400 ATEX II 1/2 G EEx d IIC T6 ... T4 Note: Requirements for NAMUR NE24 recommendation are fulfilled by ATEX EEx.		
Application	Installation in TSP temperature sensors		
Spring travel	Approx. 10 mm		
Temperature	Resistance thermometers: Basic application: -50 ... 400 °C Extended vibration resistance: -50 ... 400 °C Extended measuring range: -200 ... 600 °C Thermocouples Type K, J and N: Approx. -40 ... 1000 °C		



### Note

For higher resistance to vibrations, resistance measuring insets or thermocouples with higher resistance to vibrations are recommended.

For information on additional sensor models, sheath materials and diameters, contact your ABB sales representative.

### 3 General information

The permissible load for a temperature sensor depends on several factors:

Medium-specific factors	Installation-specific factors
<ul style="list-style-type: none"> <li>- Medium</li> <li>- Viscosity</li> <li>- Flow rate</li> <li>- Pressure</li> <li>- Temperature</li> </ul>	<ul style="list-style-type: none"> <li>- Thermowell material:</li> <li>- Thermowell form</li> <li>- Insertion depth</li> <li>- Sealable pressure of process connection</li> <li>- Vibration</li> </ul>

Considering the wide range of configuration options, it is not possible to provide generally applicable information. The following information provides recommended values. For conditions that vary significantly from those described herein, contact your ABB partner.

#### 3.1 Ambient temperature at connection head

Connection head without transmitter	-40 ... 130 °C
Connection head with transmitter	-40 ... 85 °C
Connection head with LCD display	-20 ... 70 °C

ABB's standard cable gland is suited to temperatures between -20 and 100 °C. For temperatures outside this range, the appropriate cable gland must be installed.

#### 3.2 Maximum process temperature

The maximum process temperature depends on the measuring element and thermowell material.

Thermowell material	Max. temperature
SS 316L / 1.4404	≤ 600 °C
SS 316 Ti / 1.4571	≤ 800 °C
Hastelloy C276 / 2.4819	≤ 1100 °C

These values are maximum values and do not take into consideration process-related stress. In individual cases, the values may be considerably lower.

### 3.3 Pressure and vibration resistance of thermowell

The permissible compressive loads for the various thermowells are provided in the following figures in accordance with DIN 43772 and are based on a range of temperatures.

The curves can also be applied to identical thermowell models.

#### Thermowell form 2 (material 1.4571)

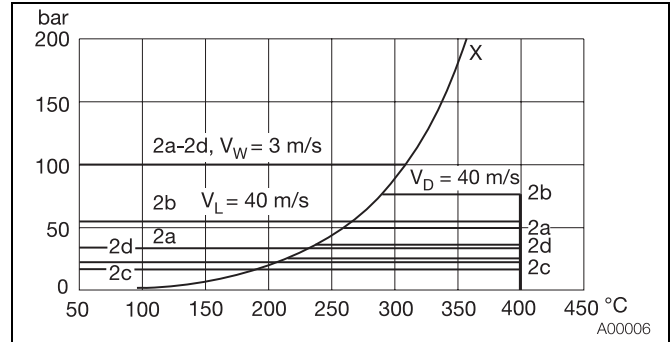

Fig. 1

X Vapor-pressure curve  
 VL Flow rate in air  
 Vw Flow rate in water  
 VD Flow rate in steam

Curve	Insertion depth [mm]	Thermowell diameter [mm]
2a	250	11
2b	250	14
2c	400	11
2d	400	14

#### Thermowell form 3 (material 1.4571)

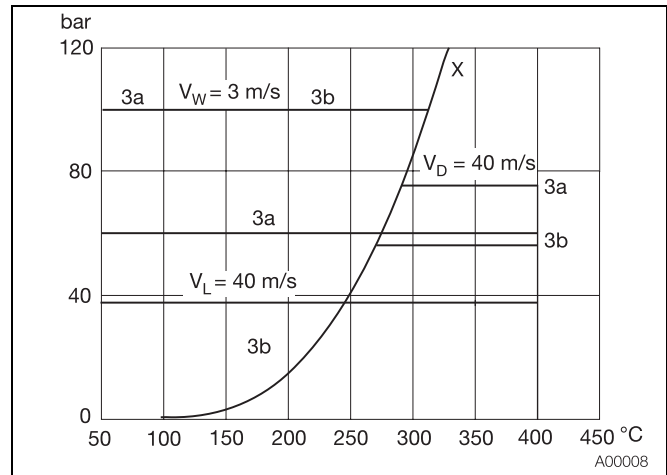

Fig. 2

X Vapor-pressure curve  
 VL Flow rate in air  
 Vw Flow rate in water  
 VD Flow rate in steam

Curve	Insertion depth [mm]	Thermowell diameter [mm]
3a	225	12/9
3b	285	12/9

**Thermowell form 4 (material 1.4571)**

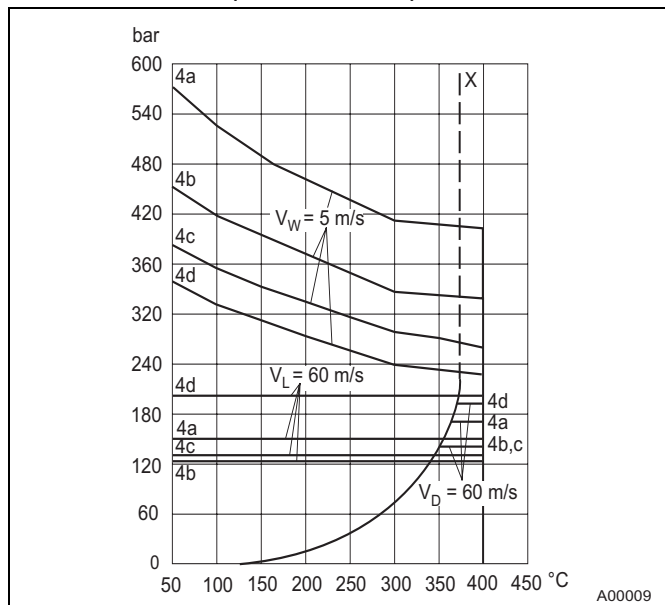

Fig. 3  
X Vapor-pressure curve       $V_L$  Flow rate in air  
 $V_W$  Flow rate in water       $V_D$  Flow rate in steam

Curve	Insertion depth [mm]	Thermowell diameter [mm]
4a	65	18
4b	125	24
4c	125	26
4d	125	32

**Thermowell form 4 (material 1.5415)**

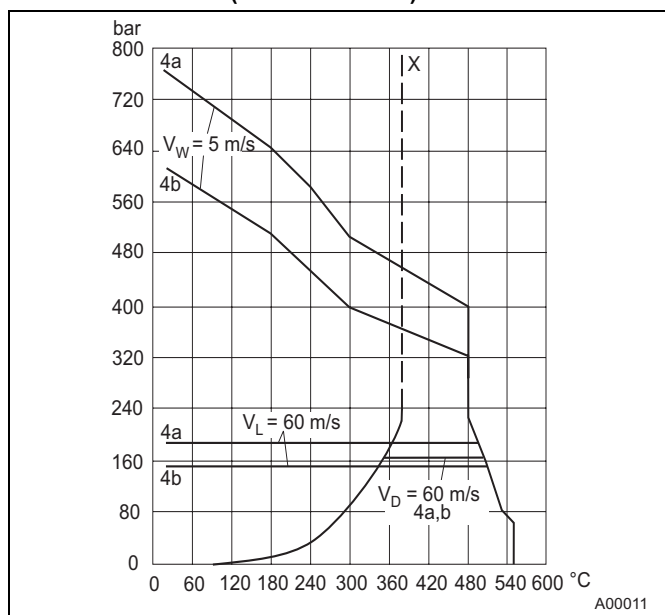

Fig. 4  
X Vapor-pressure curve       $V_L$  Flow rate in air  
 $V_W$  Flow rate in water       $V_D$  Flow rate in steam

Curve	Insertion depth [mm]	Thermowell diameter [mm]
4a	65	18
4b	125	24

**Thermowell form 4 (material 1.7335 and 1.7380)**

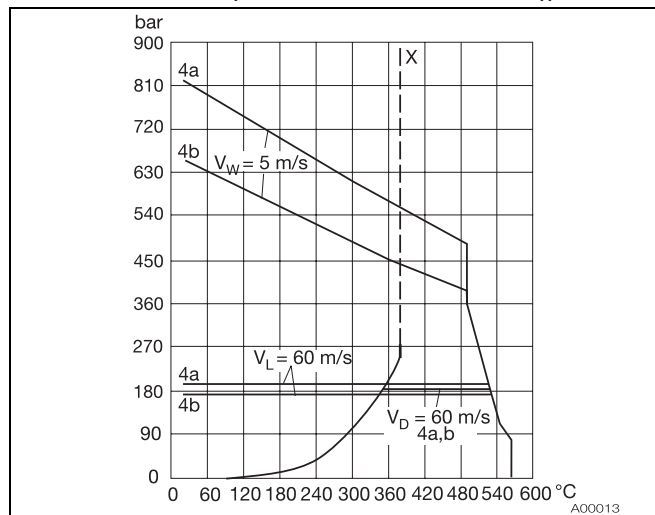

Fig. 5  
X Vapor-pressure curve       $V_L$  Flow rate in air  
 $V_W$  Flow rate in water       $V_D$  Flow rate in steam

Curve	Insertion depth [mm]	Thermowell diameter [mm]
4a	65	18
4b	125	24



**Note**

The ABB standard thermowells are sufficiently robust for most industrial applications provided that design, material and length are properly selected.

Most thermowell failures are caused by flow-related vibrations. For this reason, ABB offers a stress analysis for ABB thermowells, based on the respective usage parameters.

The stress analysis is based on ASME standards and recognized theoretical methods, and is intended to support thermowell selection.

It is not, however, a guarantee against failure of the thermowell.

### 3.4 Measuring range of measuring inset

Resistance thermometers	
Basic application	-50 ... 400 °C
Extended vibration resistance	-50 ... 400 °C
Extended measuring range	-200 ... 600 °C
Thermocouple	
Type K	-40 ... 1000 °C
Type J	-40 ... 750 °C
Type N	-40 ... 1000 °C

### 3.5 Accuracy of measuring element

#### Resistance thermometer (EN 60751)

Basic application	
Class B: $\Delta t = \pm (0.30 + 0.0050 t )$	-50 ... 400 °C
Class A: $\Delta t = \pm (0.15 + 0.0020 t )$	-30 ... 350 °C
$\Delta t = \pm (0.30 + 0.0050 t )$	-50 ... -30 / 350 ... 400 °C
1/3 Class B: $\Delta t = \pm (0.10 + 0.0017 t )$	0 ... 100 °C
$\Delta t = \pm (0.15 + 0.0020 t )$	-30 ... 0 / 100 ... 350 °C
$\Delta t = \pm (0.30 + 0.0050 t )$	-50 ... -30 / 350 ... 400 °C
Extended vibration resistance	
Class B: $\Delta t = \pm (0.30 + 0.0050 t )$	-50 ... 400 °C
Class A: $\Delta t = \pm (0.15 + 0.0020 t )$	-30 ... 350 °C
$\Delta t = \pm (0.30 + 0.0050 t )$	-50 ... -30 / 350 ... 400 °C
Extended measuring range	
Class B: $\Delta t = \pm (0.30 + 0.0050 t )$	-200 ... 600 °C
Class A: $\Delta t = \pm (0.15 + 0.0020 t )$	-200 ... 600 °C

#### Thermocouple

The measurement accuracy of the ABB standard thermocouples complies with international standard IEC 584 / EN 60584. Thermocouples compliant with ANSI MC96.1 are also available upon request. Since the values of both standards vary only marginally in the lower temperature range (up to approx. 300 °C), we recommend the use of thermocouples compliant with international standard IEC 584. The tolerance information must be defined in the table "Tolerance classes".

**Tolerance classes**

Standard	TE type	Class	Temperature range	Maximum deviation
EN 60584 / IEC 584	K (NiCr-Ni)	2	-40 ... 333 °C	±2.5 °C
			333 ... 1200 °C	±0.0075 x [t]
		1	-40 ... 375 °C	±1.5 °C
			375 ... 1000 °C	±0.0040 x [t]
	J (Fe-CuNi)	2	-40 ... 333 °C	±2.5 °C
			333 ... 750 °C	±0.0075 x [t]
		1	-40 ... 375 °C	±1.5 °C
			375 ... 750 °C	±0.0040 x [t]
	N (NiCrSiNiSi)	2	-40 ... 333 °C	±2.5 °C
			333 ... 1200 °C	±0.0075 x [t]
		1	-40 ... 375 °C	±1.5 °C
			375 ... 1000 °C	±0.0040 x [t]
Standard	TE type	Class	Temperature range	Maximum deviation
ANSI MC96.1	K (NiCr-Ni)	Standard	-0 ... 293 °C	±2.2 °C
			293 ... 1250 °C	±0.0075 x [t]
		Special	-0 ... 275 °C	±1.1 °C
			275 ... 1250 °C	±0.0040 x [t]
	J (Fe-CuNi)	Standard	-0 ... 293 °C	±2.2 °C
			293 ... 750 °C	±0.0075 x [t]
		Special	-0 ... 275 °C	±1.1 °C
			275 ... 750 °C	±0.0040 x [t]
	N (NiCrSiNiSi)	Standard	-0 ... 293 °C	±2.2 °C
			293 ... 1250 °C	±0.0075 x [t]
		Special	-0 ... 275 °C	±1.1 °C
			275 ... 1250 °C	±0.0040 x [t]

**3.6 Measurement accuracy of mounted transmitter**

For information on transmitter accuracy, refer to the documentation on transmitters.

**3.7 Vibration resistance of measuring inset**

Use of plastic-sheathed cables and special measuring elements, including their installation, results in a very high vibration resistance for all measuring insets of the TSP temperature sensor.

The acceleration values of 3 g, defined in accordance with EN 60751 (IEC 751) for additional requirements, are exceeded by all measuring inset models in TSP temperature sensors.

The following table provides an overview of the vibration resistance in accordance with EN 60751 for the measuring inset models (on hot side), as well as the temperature-sensitive sections and the non-bendable sections at the tip of the measuring inset.

Measuring inset-design	Vibration resistance EN 60751 (tip-tip)	temperature-sensitive section	non-bendable section
Pt100, Basic application (-50 ... 400 °C)	10 g	7 mm	30 mm
Pt100, Extended vibration resistance (-50 ... 400 °C)	60 g	10 mm	40 mm
Pt100, Extended measuring range (-200 ... 600 °C)	10 g	50 mm	60 mm
Thermocouple	60 g	3 mm	20 mm

**3.8 Insulation resistance of measuring inset**

The insulation resistance is measured between outside sheath and measuring circuit. In case of two measuring circuits, the insulation resistance between both measuring circuits is also measured.

**The following applies for all measuring inset models:**

$R_{iso} > 500 \text{ M}\Omega$  at 500 V DC,  $15 \text{ °C} < T_u < 35 \text{ °C}$ , relative humidity < 80%

As a result of a special process during manufacturing, ABB measuring insets also have outstanding insulation values at high temperatures.

### 3.9 Response times

Response times for temperature sensors from the TSP series are affected by the following:

- The thermowell used
- The thermal contact between thermowell and measuring inset

For TSP321 and TSP331 temperature sensors, the thermowell is adapted to the measuring inset, resulting in excellent heat transmission.

The following table shows typical response times for various ABB temperature sensors, measured in accordance with EN 60751 in water with 0.4 m/s and a temperature from 25 °C to 35 °C.

#### Resistance thermometers

Thermowell form	Diameter [mm]	T 0.5 [s]	T 0.9 [s]
3, 3G, 3F	12	12	30
2GS, 2FS	12	7	18
	14	7	18
4, 4F cone length 125	24	14	44
4, 4F cone length 65	24	20	63

#### Thermocouples

Thermowell form	Diameter [mm]	T 0.5 [s]	T 0.9 [s]
3G, 3F	12	10	24
2GS, 2FS	12	6	14
	14	6	14
4, 4F cone length 125	24	10	40
4, 4F cone length 65	24	16	50

### 3.10 Self-heating

When using ABB transmitters, self-heating can be ignored.

### 3.11 Installation instructions



#### Note

For ATEX-certified components, observe the relevant safety instructions.

#### 3.11.1 Insertion depth

The insertion depth of a temperature sensor can affect the accuracy of measurements:

- Improper sensor installation can result in measurement errors due to heat dissipation from the process connection and the tube or tank wall. (The size of the error depends on ambient conditions at the measuring point.)

#### Recommended insertion depth (to avoid heat dissipation errors)

Medium	Depth [mm]
Fluids	8 ... 10 x Ø thermowell tip
Gases	10 ... 15 x Ø thermowell tip

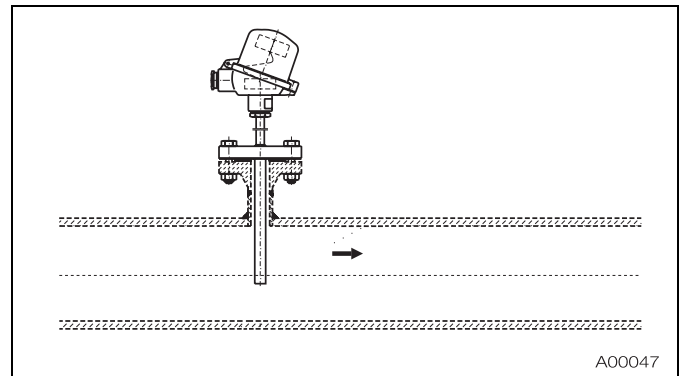

Fig. 6

#### 3.11.2 Insufficient mounting diameter

- For tubes with very small nominal diameters, oblique insertion or insertion in an elbow is recommended; the thermowell tip must be positioned against the flow of the medium.

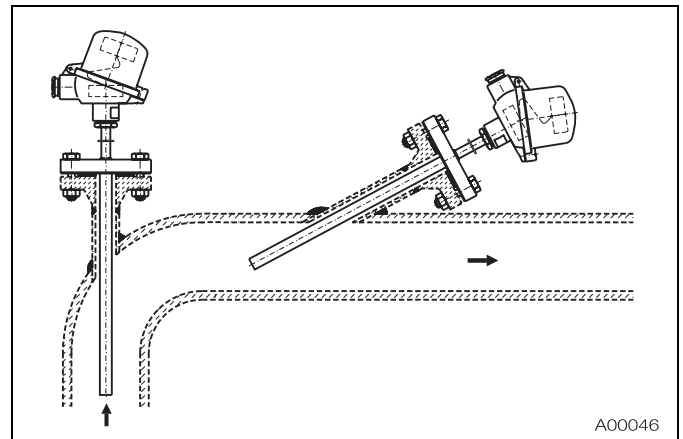

Fig. 7

## 4 Connection heads

### The connection head enables user to:

- Housing of a transmitter or a terminal block
- Protect the connection area against adverse environmental effects

A special cable guide cable automatically positions the connecting cable when feeding the connection head. The flat base of the housing ensures optimum access to the connection area.

A second cable entry is available as an option. Both versions, the one with one cable entry and the one with two cable entries, are alternatively available with a 1/2" NPTF thread (without cable gland).

All ABB standard heads provide a protection class of at least IP 66 / IP 67, in combination with an ABB thermowell and the M20 x 1.5 cable gland.

The following connection heads belong to the SensyTemp TSP300 series of temperature sensors:

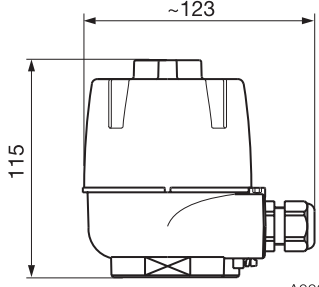
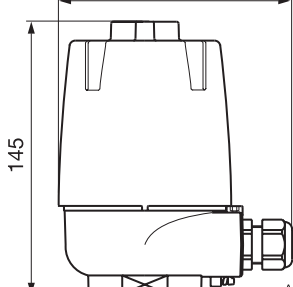
Head form	AGL / AGS	AGLH / AGSH
	 <p style="text-align: right;">A00061</p>	 <p style="text-align: right;">A00063</p>
Material	AGL Aluminum copper-free (< 0.04% Cu), epoxy-coated AGS Stainless steel	AGLH Aluminum copper-free (< 0.04% Cu), epoxy-coated AGSH Stainless steel
Built-in LCD display	No	No
Transmitter mounting	On the measuring inset	On the mounting bracket (optional on the measuring inset)

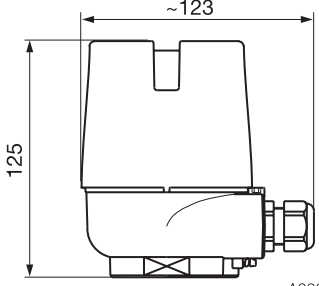
Head form	AGLD / AGSD
	 <p style="text-align: right;">A00064</p>
Material	AGLD Aluminum copper-free (< 0.04% Cu), epoxy-coated AGSD
Built-in LCD display	Yes
Transmitter mounting	On the measuring inset

## 5 Extension tubes

The extension tube is the component between the thermowell and connection head.

The extension tube performs the following functions:

- Bridge existing insulation
- Cooling section between the connection head and medium that protects the connecting point and built-in electronics against high temperatures.

	TSP321	TSP311 / TSP331:
Ext. tube length K	Length from process connection to connection head	Length from thermowell connection to connection head
Standard ext.-tube length	130 mm <sup>1)</sup>	150 mm <sup>1)</sup>
Diameter	= Ø Schutzrohr	≥ 14 mm

<sup>1)</sup> In most cases, this is the optimal length in the connection head to avoid temperatures that are too high.

The diagram in fig. 8 shows the increase in temperature in the connection head compared to the ambient temperature depending on process temperature.

This diagram can be used for orientation when measuring the ext. tube length. In actual applications, the values may differ considerably.

The operator is responsible for ensuring that the max. temperature in the connection head is maintained. This applies, in particular, to explosion risk areas.

Effect of extension tube length K [mm] on the temperature in connection head  $T_{\text{Head}}$  [°C] compared to ambient temperature

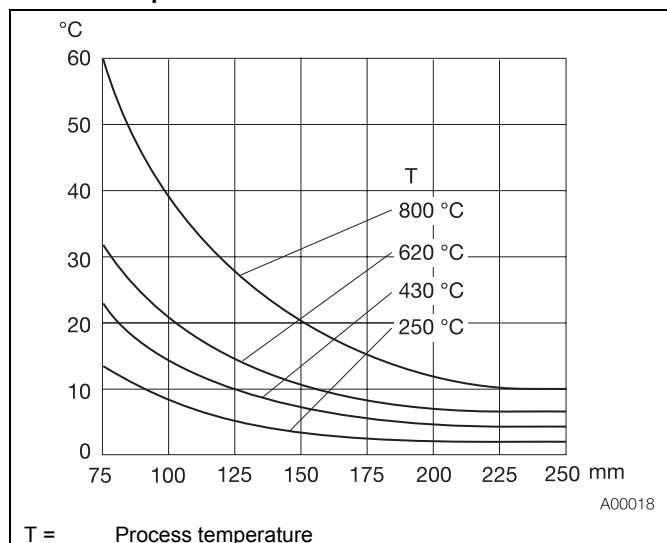
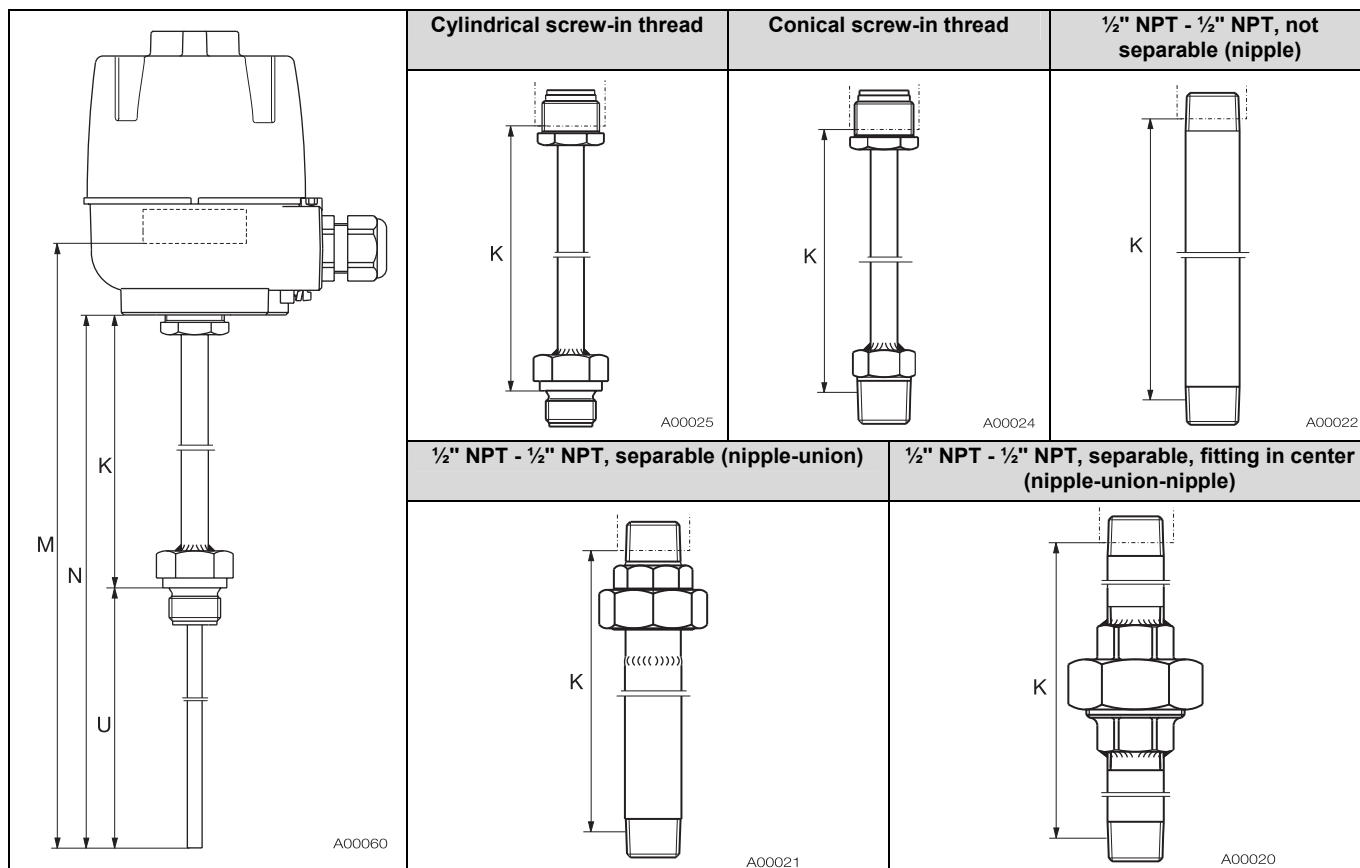

Fig. 8

### 5.1 Extension tube models



## 6 Process connections

### 6.1 SensyTemp TSP321 temperature sensor

#### 6.1.1 Welded/insertion thermowells

Model	Compression fitting
Straight tip (DIN43772 – 2)	G 1/2A, 1/2" NPT
Tapered tip (DIN43772 – 3)	
Stepped (ABB – 2S)	



**Note**

ABB supplies only compression fittings manufactured from stainless steel. Other materials are not available.

Material confirmation with acceptance test certificate in accordance with EN 10204 is not available for compression fittings.

In this case, a certificate is provided only for the thermowell material.

#### 6.1.2 Screw-in thermowells

Model	Screw-in thread
Straight (DIN43772 – 2G)	G 1/2"A, G 3/4"A, G 1"A, 1/2" NPT, 3/4" NPT, 1" NPT, M20 x 1,5, M27 x 2, 1/2" BSPT, 3/4" BSPT, 1" BSPT.
Tapered tip (DIN43772 – 3G)	
Stepped tip (ABB – 2GS)	

#### 6.1.3 Flange thermowells

Model	B1 flange, EN 1092-1	RF flange, ANSI/ASME B16.5
Straight (DIN43772 – 2F)	DN25 PN40, DN40 PN40, DN50 PN40	1" 150 lbs., 1" 300 lbs., 1,5" 150 lbs., 1,5" 300 lbs., 1,5" 600 lbs., 2" 150 lbs., 2" 300 lbs., 2" 600 lbs.
Tapered tip (DIN43772-3F)		
Stepped tip (ABB – 2FS)		

### 6.2 SensyTemp TSP331 temperature sensor

#### 6.2.1 Screw-in thermowells

Model	Screw-in thread
Thermowell manufactured from bar stock material (ABB - PS)	1/2" NPT, 3/4" NPT, 1" NPT

#### 6.2.2 Flange thermowells

Model	B1 flange, EN 1092-1	RF flange, ANSI/ASME B16.5
Thermowell manufactured from bar stock material (ABB - PE)	DN25 PN40, DN40 PN40, DN50 PN40	1" 150 lbs., 1" 300 lbs., 1,5" 150 lbs., 1,5" 300 lbs., 1,5" 600 lbs., 2" 150 lbs., 2" 300 lbs., 2" 600 lbs.
Thermowell manufactured from bar stock material (DIN 43772 – 4F, F2 = 24 mm)		
Thermowell manufactured from bar stock material, fast-acting (DIN 43772 – 4F, F2 = 18 mm, ABB – 4FS)		

## 7 Thermowells

### The thermowell performs the following functions:

- Protect against aggressive media, high process pressures and high speed flow
- Replace or recalibrate measuring unit without interrupting process

Depending on medium, temperature and process pressure, several different designs and materials are available. The thermowells are divided into 2 categories:

- Welded thermowells manufactured from pipe material (TSP321)
- Drilled thermowells manufactured from bar stock material (TSP331)

Available in accordance with DIN or ABB standards.

### Use in highly aggressive media

- Stainless steel flange thermowells can have a special coating, e.g., with 0.5 mm E-CTFE (max. 150 °C).

### Use with highly corrosive applications

- Thermowells can also have a tantalum sheath consisting of a single-sided, closed tube with 13 mm diameter and retaining ring. Requirements:
  - TSP321 with flange thermowells (form 2F or 3F)
  - 12 mm diameter
  - 1.4571 (SS 316Ti) or 1.4404 (SS 316L) materials



### Note

When selecting the insertion and nominal lengths, it is recommended that you refer to the standard lengths. This ensures cost benefits and short delivery times based on proper parts inventory.

### 7.1 Tubular thermowells

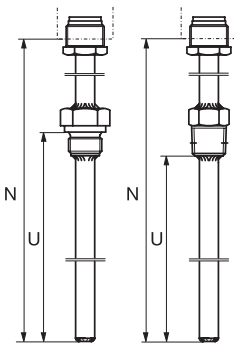
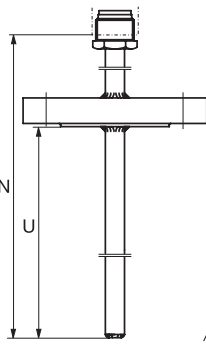
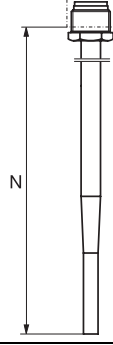
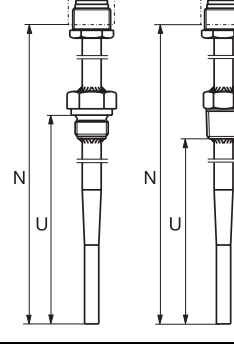
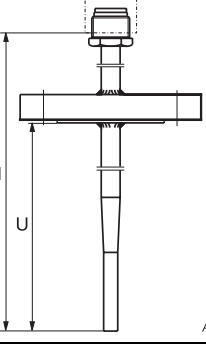
Thermowell model	DIN 43772 – Form 2		DIN 43772 – Form 2G		DIN 43772 – Form 2F	
Thermowell form						
Design	Straight shaft		Straight shaft		Straight shaft	
Material	Diameter	1.4571 12/12, 14/14 1.4404 12/12, 14/14	1.4571 12/12, 14/14 1.4404 12/12, 14/14 2.4819 <sup>1)</sup> 13,7/13,7	1.4571 12/12, 14/14 1.4404 12/12, 14/14 2.4819 <sup>2)</sup> 13,7/13,7	1.4571 12/12, 14/14 1.4404 12/12, 14/14 2.4819 <sup>2)</sup> 13,7/13,7	1.4571 12/12, 14/14 1.4404 12/12, 14/14 2.4819 <sup>2)</sup> 13,7/13,7
Standard lengths	N = 230, 290, 380, 530		U = 100 / N = 230 U = 160 / N = 290 U = 250 / N = 380 U = 400 / N = 530		U = 100 / N = 230 U = 160 / N = 290 U = 250 / N = 380 U = 400 / N = 530	
Thermowell model	DIN 43772 – Form 3		DIN 43772 – Form 3G		DIN 43772 – Form 3F	
Thermowell form						
Design	Tapered tip		Tapered tip		Tapered tip	
Material	Diameter	1.4571 12/9 1.4404 12/9	1.4571 12/9 1.4404 12/9	1.4571 12/9 1.4404 12/9	1.4571 12/9 1.4404 12/9	1.4571 12/9 1.4404 12/9
Standard lengths	N = 230, 290, 380, 530		U = 100 / N = 230 U = 160 / N = 290 U = 250 / N = 380 U = 400 / N = 530		U = 100 / N = 230 U = 160 / N = 290 U = 250 / N = 380 U = 400 / N = 530	

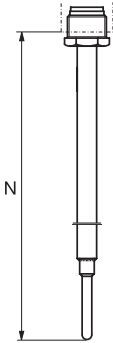
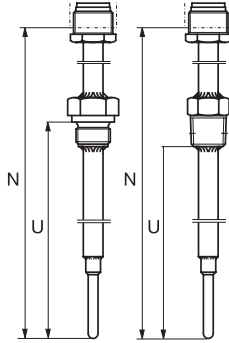
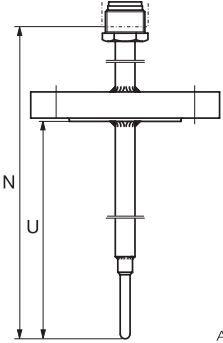
Thermowell model	ABB – Form 2S		ABB – Form 2GS		ABB – Form 2FS		
Thermowell form							
	A00033		A00035		A00034		
Design	Stepped tip		Stepped tip		Stepped tip		
Material	Diameter	1.4571	12/6, 14/6	1.4571	12/6, 14/6	1.4571	12/6, 14/6
	Diameter (shaft/tip)	1.4404	12/6, 14/6	1.4404	12/6, 14/6	1.4404	12/6, 14/6
				2.4819 <sup>1)</sup>	13,7/6	2.4819 <sup>2)</sup>	13.7/6
Standard lengths	N = 230, 290, 380, 530		U = 100 / N = 230 U = 160 / N = 290 U = 250 / N = 380 U = 400 / N = 530		U = 100 / N = 230 U = 160 / N = 290 U = 250 / N = 380 U = 400 / N = 530		

Measurements in mm

<sup>1)</sup> only with G1/2A, 1/2" NPT thread

<sup>2)</sup> 1.4571 backing flange, 2.4819 flange disc

## 7.2 Drilled thermowells

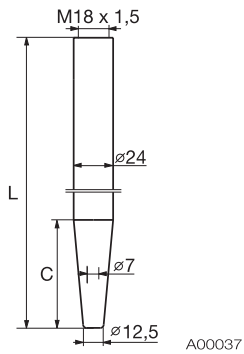
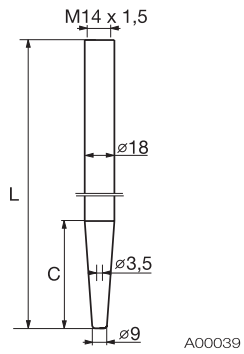
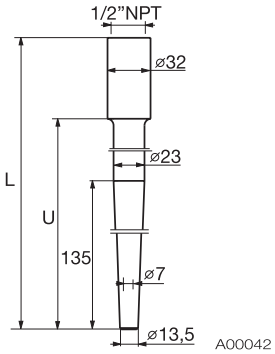
Thermowell model	DIN 43772 - Form 4 - M18 x 1.5	ABB – Form 4S (DIN 43772 – Form 4 - M14 x 1.5)	ABB - Form PW
Thermowell form			
Design	Weld-in thermowell	Weld-in thermowell	Weld-in thermowell
Material	Diameter (shaft/tip) 1.4571, 1.4404, 1.7335, 1.5415	1.4571, 1.4404, 1.7335, 1.5415	1.4404, 1.4571, 2.4819, 1.4876, 2.4360, 2.4816
Standard lengths	L = 140 / C = 65 L = 200 / C = 65 L = 200 / C = 125 L = 260 / C = 125 L = 410 / C = 275	L = 110 / C = 65 L = 140 / C = 65	U = 100, 150, 200, 250, 300, 350 L = U + 65

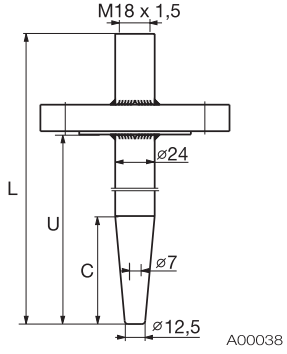
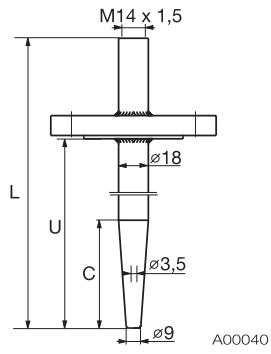
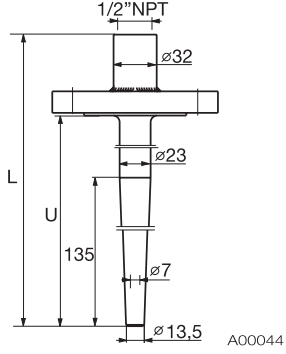
Thermowell model	DIN 43772 - Form 4F - M18 x 1.5	ABB – Form 4FS (DIN 43772 - Form 4FS M14 x 1.5)	ABB - Form PF
Thermowell form			
Design	Flange thermowell	Flange thermowell	Flange thermowell
Material	Diameter (shaft/tip) 1.4571, 1.4404	1.4571, 1.4404	1.4404, 1.4571, 2.4819, 1.4876, 2.4360, 2.4816 <sup>1)</sup>
Standard lengths	U = 130 / L = 200 / C = 65 U = 190 / L = 260 / C = 125 U = 340 / L = 410 / C = 275		U = 100, 150, 200, 250, 300, 350 L = U + 65

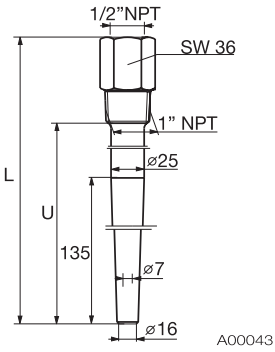
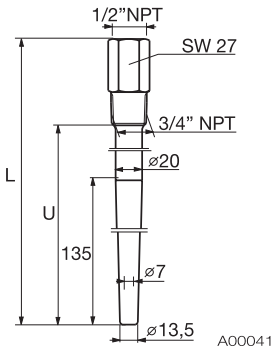
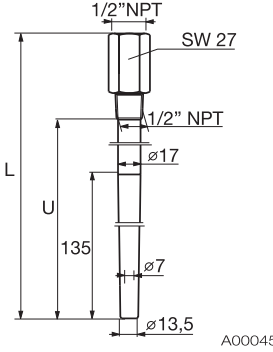
Thermowell model		ABB - Form PS		
Thermowell form				
Design	Screw-in thermowell, 1" NPT thread	Screw-in thermowell, 3/4" NPT thread	Screw-in thermowell, 1/2" NPT thread	
Material	Diameter (shaft/tip)	1.4404, 1.4571, 2.4819, 25/16 1.4876, 2.4360, 2.4816	1.4404, 1.4571, 2.4819, 20/13,5 1.4876, 2.4360, 2.4816	1.4404, 1.4571, 2.4819, 17/13,5 1.4876, 2.4360, 2.4816
Standard lengths	U = 100, 150, 200, 250, 300, 350 L = U + 65	U = 100, 150, 200, 250, 300, 350 L = U + 65	U = 100, 150, 200, 250, 300, 350 L = U + 65	

Measurements in mm

<sup>1)</sup> 1.4876, 2.4360, 2.4816, 2.4819 with 1.4571 flange and flange disc

## 8 Transmitter

Installing a transmitter has the following advantages:

- Reduces cost due to less wiring expense
- Stronger sensor signal at measuring point and conversion to standard signal (also increases interference immunity)
- Option to install LCD display in the connection head.

The output signal of a temperature sensor is determined by selecting the corresponding transmitter.

The following output signals are available:

- 4 ... 20 mA
- HART
- PROFIBUS PA
- FOUNDATION Fieldbus



### Note

For additional information, refer to the documentation on transmitters.

## 9 On-site display

The connection heads AGLD and AGSD are equipped with a digital LCD display that is connected via digital interface to a compatible transmitter.

The display can be connected to the following transmitters:

- TTH300 (HART)
- TF02 (FOUNDATION Fieldbus)

The display can typically be used as a configuration tool for the TTH 300.

## 10 Functional safety (SIL)

The SensyTemp TSP temperature sensors are available with certificate of conformity for use in safety-relevant applications, including SIL Level 2.

This applies for temperature sensors without transmitter as well as with built-in TTH300 transmitter.

Information regarding functional safety for SensyTemp TSP temperature sensors can be found in the SIL safety instructions.

## 11 Approvals

TSP3X1 temperature sensors are approved for a variety of applications.

Approvals range from metrological to Ex certification for individual countries as well as EC-wide ATEX certificates.

These include the following certificates:

- ATEX EEx i No. PTB 01 ATEX 2200 X
- ATEX Dust ignition proof No. BVS 06 ATEX E 029
- ATEX EEx d No. PTB 99 ATEX 1144
- GOST Russia
- GOST Kazakhstan
- GOST Ukraine

ABB temperature sensors compliant with ATEX EEx i also meet requirements for the NAMUR NE21 recommendation.

## 12 Tests and certificates

To increase the safety and accuracy of your processes, ABB provides a number of mechanical and electrical tests. The results of these tests are certified in accordance with EN 10204.

The following EN 10204 certificates are available:

- Certificate of compliance with the order 2.1
- Acceptance test certificate 3.1 for the following checks:
  - Material confirmation for media parts in contact with media



### Note

For thermowell forms 2, 3 and 2S with compression fitting, a certificate is provided for the thermowell only, not for the compression fitting supplied.

- Visual, metric and functional checks of temperature sensor
  - Helium leakage test of thermowell
  - X-ray inspection of thermowell
  - Dye penetration test at the weld seams of the thermowell
  - Compression test of thermowell
  - Comparison measurement for calibration of measuring inset
- Acceptance test certificate 3.2 is available upon request

For measurements requiring extremely high accuracy, ABB can calibrate the temperature sensor at its own DKD calibration lab.

When DKD calibration is performed, a separate certificate is provided for each temperature sensor.

Comparison measurements and DKD calibrations are performed on the measuring inset or, if applicable, on the transmitter.

To obtain accurate measurements, observe the **minimum length** for measuring inset:

- For low to medium temperatures: 100 ... 150 mm
- For temperatures above 500 °C: 300 ... 350 mm

These are recommended values. If in doubt, your ABB partner is available for on-site assistance.

For comparison measurements and DKD calibration, individual characteristics of the temperature sensor can be calculated and a separate transmitter can be programmed based on freestyle characteristics.

Adjusting the transmitter to the sensor characteristics can considerably improve the measuring accuracy of the temperature sensor. When doing so, perform measurements at a minimum of three different temperatures.

## 13 Additional information

### 13.1 Delivery times

Typical delivery times for small ( $\leq 10$  units) to medium ( $\leq 50$  units) quantities and standard models are 3 to 20 days, depending on configuration.

### 13.2 Supplementary documents

Device	Data sheet
<b>Temperature transmitter for sensor head mounting</b>	
TR04-Eco, TR04-Ex 4 ... 20 mA	10/11-8.14
TH01, TH01-Ex 4 ... 20 mA configurable	3KDE115080R1003
TH02, TH02-Ex HART	10/11-8.19
TF12, TF12-Ex PA	10/11-8.26
TF02, TF02-Ex FF	10/11-8.25
TTH300 HART sensor redundancy	DS/TTH300
<b>Exchangeable of measuring insets SensyTemp TSA101</b>	DS/TSA101

### 13.3 Information about ordering information.

The order codes cannot be combined in any order with each other. For questions regarding installation feasibility, contact your ABB partner.

## 14 Ordering information

### 14.1 SensyTemp TSP311

Temperature Sensor SensyTemp TSP311	Variant digit No.	1 - 7	8	9	10	11	12	13	14	15	16	17	Code				
	Catalog No.	TSP311-															
<b>Explosion protection / approval</b>																	
Without			Y	0													
Intrinsic Safety: ATEX II 1 G EEx ia IIC T6 ... T1 - Zone 0, 1, 2			A	1													
Dust ignition proof: ATEX II 1 D IP6X T133 ... T400 - Zone 20, 21, 22			A	3													
Dust ignition proof and intrinsic safety: ATEX II 1 D IP6X T133 ... T400 and ATEX II 1 G EEx ia IIC T6 ... T1 - Zone 0, 1, 2, 20, 21, 22			A	4													
Flameproof Enclosure: ATEX II 1/2 G EEx d IIC T6 ... T4 - Zone 1			A	5													
ATEX II 3 G EEx nA II T6 ... T1			B	1													
and ATEX II 3 D IP6X T133 ... T400 - Zone 2 and 22																	
Others			Z	9													
<b>Extension tube length K</b>																	
150 mm							K	1									
Variable extension tube length (price per each commencing 100 mm)							Z	9									
<b>Thermowell connection</b>																	
Parallel thread G 1/2 in A							G	1									
Parallel thread M14 x 1.5							M	1									
Parallel thread M18 x 1.5							M	2									
Parallel thread M20 x 1.5							M	3									
Tapered thread 1/2 in NPT							N	1									
Nipple 1/2 in NPT - 1/2 in NPT							N	2									
Nipple-union 1/2 in NPT - 1/2 in NPT							N	3									
Others							Z	9									
<b>Immersion length U</b>																	
U = 140 mm													U	2			
U = 200 mm													U	4			
U = 260 mm													U	6			
Acc. to customer specification (price per each commencing 100 mm)													Z	9			
<b>Measuring inset type</b>																	
Resistance thermometer, basic application, measuring range -50 ... 400 °C													S	1			
Resistance thermometer, extended vibration resistance, measuring range -50 ... 400 °C													S	2			
Resistance thermometer, extended measuring range -200 ... 600 °C													D	1			
Thermocouple													T	1			
Others													Z	9			

Continued on next page

Temperature Sensor SensyTemp TSP311	Variant digit No.													Code				
	1	2	3	4	5	6	7	8	9	10	11	12	13					
<b>Measuring inset diameter</b>	<b>Catalog No. TSP311-</b>																	
3 mm														D	3			
6 mm														D	6			
6 mm, tip with additional sleeve 8 mm														H	8			
6 mm, tip with additional sleeve 10 mm														H	1			
Others														Z	9			
<b>Sensor type and wiring</b>																		
1 x Pt100, 2-wire														P	1			
1 x Pt100, 3-wire														P	2			
1 x Pt100, 4-wire														P	3			
2 x Pt100, 2-wire														P	4			
														P	4			
2 x Pt100, 3-wire														P	5			
														P	5			
2 x Pt100, 4-wire														P	6			
														P	6			
1 x Type K (NiCr-Ni)														K	1			
2 x Type K (NiCr-Ni)														K	2			
1 x Type J (Fe-CuNi)														J	1			
2 x Type J (Fe-CuNi)														J	2			
1 x Type N (NiCrSi-NiSi)														N	1			
2 x Type N (NiCrSi-NiSi)														N	2			
Others														Z	9			
<b>Sensor accuracy</b>																		
Standard accuracy EN 60751 class B														B	2			
Extended accuracy EN 60751 class A from -30 ... 350 °C														S	1			
Extended accuracy EN 60751 class A from -200 ... 600 °C														D	1			
Standard accuracy EN 60584 class 2														T	2			
Extended accuracy EN 60584 class 1														T	1			
High accuracy EN 60751 1/3 class B from 0 ... 100 °C														S	3			
Others														Z	9			

Continued on next page

Temperature Sensor	Variant digit No.	1 - 7	18	19	20	21	22	23	24	25	26	27	Code			
<b>SensyTemp TSP311</b>	Catalog No.	<b>TSP311-</b>														
<b>Connection head</b>																
AGL / aluminium, screwed cover													L 1			
AGLH / aluminium, high cover, screwed													L 2			
AGLD / aluminium, screwed cover with display													L 4			
AGS / stainless steel, screwed cover													S 1			
AGSH / stainless steel, high cover, screwed													S 2			
AGSD / stainless steel, screwed cover with display													S 4			
Others													Z 9			
<b>Transmitter</b>																
Without transmitter, measuring inset with ceramic terminal block													Y 1			
Without transmitter, measuring inset with flying leads													Y 2			
TR04, fixed range, output signal 4 ... 20 mA																
2/3-wire circuit													R 1			
4-wire circuit													R 1			
TR04-Ex, fixed range, output signal 4 ... 20 mA																
2/3-wire circuit													R 2			
4-wire circuit													R 2			
TH01, programmable, output signal 4 ... 20 mA													P 1			
TH01-Ex, programmable, output signal 4 ... 20 mA													P 2			
TH02, programmable, output signal 4 ... 20 mA, HART													H 1			
TH02-Ex, programmable, output signal 4 ... 20 mA, HART													H 2			
TTH300, programmable, output signal 4 ... 20 mA, HART													H 4			
TTH300 (Ex-version), programmable, output signal 4 ... 20 mA, HART													H 5			
TF12, programmable, output PROFIBUS PA													F 1			
TF12-Ex, programmable, output PROFIBUS PA													F 2			
TF02, programmable, output FOUNDATION Fieldbus													F 3			
TF02-Ex, programmable, output FOUNDATION Fieldbus													F 4			
Others													Z 9			

**Additional ordering information**

Temperature Sensor SensyTemp TSP311	Code			
<b>Name plate</b> Stainless steel plate with TAG no.	T1			
<b>Certificates</b> TÜV certificate for functional safety SIL2 acc. IEC61508 Declaration of compliance with the order 2.1 acc. to EN 10204 Inspection certificate 3.1 acc. to EN 10204 for visual, dimensional and functional test Inspection certificate 3.1 acc. to EN 10204 for sensor calibration 1 x Pt100 Inspection certificate 3.1 acc. to EN 10204 for sensor calibration 2 x Pt100 Inspection certificate 3.1 acc. to EN 10204 for sensor calibration 1 x thermocouple Inspection certificate 3.1 acc. to EN 10204 for sensor calibration 2 x thermocouple DKD sensor calibration 1 x Pt100, separate calibration certificate for each thermometer DKD sensor calibration 2 x Pt100, separate calibration certificate for each thermometer DKD sensor calibration 1 x thermocouple, separate calibration certificate for each thermometer DKD sensor calibration 2 x thermocouple, separate calibration certificate for each thermometer Others	CS C4 C6  CD CE CF CG CH CJ CK CL CZ			
<b>Temperatures for sensor calibration</b> 0 °C / 32 °F 100 °C / 212 °F 400 °C / 752 °F 0 °C and 100 °C / 32 °F and 212 °F 0 °C and 400 °C / 32 °F and 752 °F 0 °C, 100 °C and 200 °C / 32 °F, 212 °F and 392 °F 0 °C, 200 °C and 400 °C / 32 °F, 392 °F and 752 °F As specified by customer (price per calibration point)	V1 V2 V3 V4 V5 V7 V8 V6			
<b>Temperatures for DKD calibration</b> 0 °C / 32 °F 100 °C / 212 °F 400 °C / 752 °F 0 °C and 100 °C / 32 °F and 212 °F 0 °C and 400 °C / 32 °F and 752 °F 0 °C, 100 °C and 200 °C / 32 °F, 212 °F and 392 °F 0 °C, 200 °C and 400 °C / 32 °F, 392 °F and 752 °F As specified by customer (price per calibration point)	D1 D2 D3 D4 D5 D7 D8 D6			

**Additional ordering information**

Temperature Sensor SensyTemp TSP311	Code			
<b>Cable entry options</b>				
1 x 1/2 in NPT, without cable gland	U2			
2 x 1/2 in NPT, without cable gland	U5			
2 x M20 x 1.5, with plastic cable gland, cable diameter 5 ... 12 mm	U7			
2 x M20 x 1.5, with EEx-d cable gland, cable diameter 6.0 ... 7.5 mm	UC			
Others	UZ			
<b>Transmitter measuring range</b>				
-30 ... 60 °C	A1			
-20 ... 40 °C	A2			
0 ... 40 °C	A3			
0 ... 60 °C	A4			
0 ... 100 °C	A5			
0 ... 120 °C	A6			
0 ... 150 °C	A7			
0 ... 200 °C	A8			
0 ... 250 °C	AF			
0 ... 300 °C	AG			
0 ... 400 °C	AH			
0 ... 600 °C	AJ			
0 ... 800 °C	AK			
0 ... 1000 °C	AL			
0 ... 1200 °C	AM			
0 ... 1400 °C	AN			
0 ... 1600 °C	AP			
Others	AZ			

14.2 SensyTemp TSP321

Temperature Sensor SensyTemp TSP321	Variant digit No.	1 - 7	8	9	10	11	12	13	14	15	16	17	Code				
	Catalog No.	TSP321-															
<b>Explosion protection / approval</b>																	
Without				Y	0												
Intrinsic Safety: ATEX II 1 G EEx ia IIC T6 ... T1 - Zone 0, 1, 2				A	1												
Dust ignition proof: ATEX II 1 D IP6X T133 ... T400 - Zone 20, 21, 22				A	3												
Dust ignition proof and intrinsic safety: ATEX II 1 D IP6X T133 ... T400 and ATEX II 1 G EEx ia IIC T6 ... T1 - Zone 0, 1, 2, 20, 21, 22				A	4												
Flameproof Enclosure: ATEX II 1/2 G EEx d IIC T6 ... T4 - Zone 1				A	5												
ATEX II 3 G EEx nA II T6 ... T1 and ATEX II 3 D IP6X T133 ... T400 - Zone 2 and 22				B	1												
Others				Z	9												
<b>Material of wetted parts</b>																	
Stainless steel 316 L / 1.4404				S	1												
Stainless steel 316 Ti / 1.4571				S	2												
Hastelloy C276 / 2.4819 (Backing flange stainless steel with flange disc Hastelloy C276)				N	1												
Others				Z	9												
<b>Thermowell type</b>																	
Tubular thermowell with straight shaft (Form 2 acc. to DIN 43772)				A	1												
Flanged tubular thermowell with straight shaft (Form 2F acc. to DIN 43772)				A	2												
Screwed tubular thermowell with straight shaft (Form 2G acc. to DIN 43772)				A	3												
Tubular thermowell, tapered (Form 3 acc. to DIN 43772)				C	1												
Flanged tubular thermowell, tapered (Form 3F acc. to DIN 43772)				C	2												
Screwed tubular thermowell, tapered (Form 3G acc. to DIN 43772)				C	3												
Tubular thermowell, reduced tip (ABB Form 2S)				B	1												
Flanged tubular thermowell, reduced tip (ABB-Form 2FS)				B	2												
Screwed tubular thermowell, reduced tip (ABB-Form 2GS)				B	3												
Others				Z	9												

Continued on next page

Temperature Sensor	Variant digit No.	1 - 7	8	9	10	11	12	13	14	15	16	17	Code			
<b>SensyTemp TSP321</b>	Catalog No.	<b>TSP321-</b>														
<b>Process connection</b>																
Without process connection									Y	0	0					
Adjustable compression fitting G 1/2 in, stainless steel material									A	0	1					
Adjustable compression fitting 1/2 in NPT, stainless steel material									A	0	2					
Parallel thread G 1/2 in A									S	0	1					
Parallel thread G 3/4 in A									S	0	2					
Parallel thread G 1 in A									S	0	3					
Tapered thread 1/2 in NPT									S	0	4					
Tapered thread 3/4 in NPT									S	0	5					
Tapered thread 1 in NPT									S	0	6					
Parallel thread M20 x 1.5									S	0	7					
Parallel thread M27 x 2									S	0	8					
Tapered thread 1/2 in BSPT									S	0	9					
Tapered thread 3/4 in BSPT									S	1	0					
Tapered thread 1 in BSPT									S	1	1					
Flange DN 25 PN10 ... PN40, Form B1 acc. to EN 1092-1									F	0	3					
Flange DN 40 PN10 ... PN40, Form B1 acc. to EN 1092-1									F	0	4					
Flange DN 50 PN10 ... PN40, Form B1 acc. to EN 1092-1									F	0	5					
Flange 1 in 150 lbs., Form RF acc. to ANSI/ASME B16.5									F	0	7					
Flange 1 in 300 lbs., Form RF acc. to ANSI/ASME B16.5									F	0	8					
Flange 1.5 in 150 lbs., Form RF acc. to ANSI/ASME B16.5									F	1	1					
Flange 1.5 in 300 lbs., Form RF acc. to ANSI/ASME B16.5									F	1	2					
Flange 1.5 in 600 lbs., Form RF acc. to ANSI/ASME B16.5									F	1	3					
Flange 2 in 150 lbs., Form RF acc. to ANSI/ASME B16.5									F	1	5					
Flange 2 in 300 lbs., Form RF acc. to ANSI/ASME B16.5									F	1	6					
Flange 2 in 600 lbs., Form RF acc. to ANSI/ASME B16.5									F	1	7					
Others									Z	9	9					

Continued on next page

Temperature Sensor SensyTemp TSP321	Variant digit No.	1 - 7	17	18	19	20	21	22	23	24	25	26	Code				
	Catalog No.	TSP321-															
<b>Thermowell diameter</b>																	
12 mm			A	3													
14 mm			A	4													
13.7 mm			B	2													
Others			Z	9													
<b>Immersion length U</b>																	
Without fixed immersion length			Y	0													
U = 100 mm			U	1													
U = 160 mm			U	3													
U = 250 mm			U	5													
U = 400 mm			U	7													
Acc. to customer specification			Z	9													
<b>Nominal length N</b>																	
N = 230 mm							N	1									
N = 290 mm							N	3									
N = 380 mm							N	5									
N = 530 mm							N	7									
Acc. to customer specification (price per each commencing 100 mm)							Z	9									
Acc. to customer specification (material Hastelloy C276)							Z	9									
<b>Measuring inset type</b>																	
Resistance thermometer, basic application, measuring range -50 ... 400 °C							S	1									
Resistance thermometer, extended vibration resistance, measuring range -50 ... 400 °C							S	2									
Resistance thermometer, extended measuring range -200 ... 600 °C							D	1									
Thermocouple							T	1									
Others							Z	9									
<b>Sensor type and wiring</b>																	
1 x Pt100, 2-wire											P	1					
1 x Pt100, 3-wire											P	2					
1 x Pt100, 4-wire											P	3					
2 x Pt100, 2-wire											P	4					
											P	4					
2 x Pt100, 3-wire											P	5					
											P	5					
2 x Pt100, 4-wire											P	6					
											P	6					
1 x Type K (NiCr-Ni)											K	1					
2 x Type K (NiCr-Ni)											K	2					
1 x Type J (Fe-CuNi)											J	1					
2 x Type J (Fe-CuNi)											J	2					
1 x Type N (NiCrSi-NiSi)											N	1					
2 x Type N (NiCrSi-NiSi)											N	2					
Others											Z	9					

Continued on next page

Temperature Sensor	Variant digit No.	1 - 7	23	24	25	26	27	28	29	30	31	32	Code			
<b>SensyTemp TSP321</b>	Catalog No.	<b>TSP321-</b>														
<b>Sensor accuracy</b>																
Standard accuracy EN 60751 class B																
Extended accuracy EN 60751 class A from -30 ... 350 °C																
Extended accuracy EN 60751 class A from -200 ... 600 °C																
Standard accuracy EN 60584 class 2																
Extended accuracy EN 60584 class 1																
High accuracy EN 60751 1/3 class B from 0 ... 100 °C																
Others																
<b>Connection head</b>																
AGL / aluminium, screwed cover																
AGLH / aluminium, high cover, screwed																
AGLD / aluminium, screwed cover with display																
AGS / stainless steel, screwed cover																
AGSH / stainless steel, high cover, screwed																
AGSD / stainless steel, screwed cover with display																
Others																
<b>Transmitter</b>																
Without transmitter, measuring inset with ceramic terminal block																
Without transmitter, measuring inset with flying leads																
TR04, fixed range, output signal 4 ... 20 mA																
2/3-wire circuit																
4-wire circuit																
TR04-Ex, fixed range, output signal 4 ... 20 mA																
2/3-wire circuit																
4-wire circuit																
TH01, programmable, output signal 4 ... 20 mA																
TH01-Ex, programmable, output signal 4 ... 20 mA																
TH02, programmable, output signal 4 ... 20 mA, HART																
TH02-Ex, programmable, output signal 4 ... 20 mA, HART																
TTH300, programmable, output signal 4 ... 20 mA, HART																
TTH300 (Ex-version), programmable, output signal 4 ... 20 mA, HART																
TF12, programmable, output PROFIBUS PA																
TF12-Ex, programmable, output PROFIBUS PA																
TF02, programmable, output FOUNDATION Fieldbus																
TF02-Ex, programmable, output FOUNDATION Fieldbus																
Others																

**Additional ordering information**

Temperature Sensor SensyTemp TSP321	Code			
<b>Name plate</b> Stainless steel plate with TAG no.	T1			
<b>Certificates</b> TÜV certificate for functional safety SIL2 acc. IEC61508 Material monitoring with inspection certificate 3.1 acc. to EN 10204 for wetted parts Declaration of compliance with the order 2.1 acc. to EN 10204 Inspection certificate 3.1 acc. to EN 10204 for visual, dimensional and functional test Inspection certificate 3.1 acc. to EN 10204 for helium leak test Inspection certificate 3.1 acc. to EN 10204 for X-ray test Inspection certificate 3.1 acc. to EN 10204 for dye penetration test Inspection certificate 3.1 acc. to EN 10204 for pressure test on thermowell Inspection certificate 3.1 acc. to EN 10204 for sensor calibration 1 x Pt100 Inspection certificate 3.1 acc. to EN 10204 for sensor calibration 2 x Pt100 Inspection certificate 3.1 acc. to EN 10204 for sensor calibration 1 x thermocouple Inspection certificate 3.1 acc. to EN 10204 for sensor calibration 2 x thermocouple DKD sensor calibration 1 x Pt100, separate calibration certificate for each thermometer DKD sensor calibration 2 x Pt100, separate calibration certificate for each thermometer DKD sensor calibration 1 x thermocouple, separate calibration certificate for each thermometer DKD sensor calibration 2 x thermocouple, separate calibration certificate for each thermometer <b>Others</b>	CS <b>C2</b> C4 C6 C7 C8 C9 <b>CB</b> CD CE CF CG CH CJ CK CL CZ			
<b>Temperatures for sensor calibration</b> 0 °C / 32 °F 100 °C / 212 °F 400 °C / 752 °F 0 °C and 100 °C / 32 °F and 212 °F 0 °C and 400 °C / 32 °F and 752 °F 0 °C, 100 °C and 200 °C / 32 °F, 212 °F and 392 °F 0 °C, 200 °C and 400 °C / 32 °F, 392 °F and 752 °F As specified by customer (price per calibration point)	V1 V2 V3 V4 V5 V7 V8 V6			
<b>Temperatures for DKD calibration</b> 0 °C / 32 °F 100 °C / 212 °F 400 °C / 752 °F 0 °C and 100 °C / 32 °F and 212 °F 0 °C and 400 °C / 32 °F and 752 °F 0 °C, 100 °C and 200 °C / 32 °F, 212 °F and 392 °F 0 °C, 200 °C and 400 °C / 32 °F, 392 °F and 752 °F As specified by customer (price per calibration point)	D1 D2 D3 D4 D5 D7 D8 D6			

**Additional ordering information**

Temperature Sensor SensyTemp TSP321	Code			
<b>Thermowell options</b>				
Thermowell stainless steel with additional tantalum sleeve	S1			
Thermowell coated with 0.5 mm E-CTFE / Halar, wetted parts incl. flange surface	S2			
Thermowell clean for oxygen service	S9			
Others	SZ			
<b>Flange connection options</b>				
Flange facing with groove form C acc. to EN 1092-1	F1			
Flange facing with tongue form D acc. to EN 1092-1	F2			
Flange facing with RTJ surface acc. to ANSI/ASME B16.5	F3			
Others	FZ			
<b>Cable entry options</b>				
1 x 1/2 in NPT, without cable gland	U2			
2 x 1/2 in NPT, without cable gland	U5			
2 x M20 x 1.5, with plastic cable gland, cable diameter 5 ... 12 mm	U7			
2 x M20 x 1.5, with EEx-d cable gland, cable diameter 6.0 ... 7.5 mm	UC			
Others	UZ			
<b>Transmitter measuring range</b>				
-30 ... 60 °C	A1			
-20 ... 40 °C	A2			
0 ... 40 °C	A3			
0 ... 60 °C	A4			
0 ... 100 °C	A5			
0 ... 120 °C	A6			
0 ... 150 °C	A7			
0 ... 200 °C	A8			
0 ... 250 °C	AF			
0 ... 300 °C	AG			
0 ... 400 °C	AH			
0 ... 600 °C	AJ			
0 ... 800 °C	AK			
0 ... 1000 °C	AL			
0 ... 1200 °C	AM			
0 ... 1400 °C	AN			
0 ... 1600 °C	AP			
Others	AZ			

14.3 SensyTemp TSP331

Temperature Sensor SensyTemp TSP331	Variant digit No.	1 - 7	8	9	10	11	12	13	14	15	Code			
	Catalog No.	TSP331-												
<b>Explosion protection / approval</b>														
Without				Y	0									
Intrinsic Safety: ATEX II 1 G EEx ia IIC T6 ... T1 - Zone 0, 1, 2				A	1									
Dust ignition proof: ATEX II 1 D IP6X T133 ... T400 - Zone 20, 21, 22				A	3									
Dust ignition proof and intrinsic safety: ATEX II 1 D IP6X T133 ... T400 and ATEX II 1 G EEx ia IIC T6 ... T1 - Zone 0, 1, 2, 20, 21, 22				A	4									
Flameproof Enclosure: ATEX II 1/2 G EEx d IIC T6 ... T4 - Zone 1				A	5									
ATEX II 3 G EEx nA II T6 ... T1 and ATEX II 3 D IP6X T133 ... T400 - Zone 2 and 22				B	1									
Others				Z	9									
<b>Material of wetted parts</b>														
Stainless steel 316 L / 1.4404				S	1									
Stainless steel 316 Ti / 1.4571				S	2									
High temperature steel 1.7335 (13CrMo44)				W	1									
High temperature steel 1.5415 (15Mo3)				W	3									
Hastelloy C276 / 2.4819 (Backing flange stainless steel with flange disc Hastelloy C276)				N	1									
Monel alloy 400 / 2.4360 (Backing flange stainless steel with flange disc Monel 400)				N	4									
Incoloy alloy 800 / 1.4876 (Backing flange stainless steel with flange disc Incoloy 800)				H	4									
Inconel 600 / 2.4816 (Backing flange stainless steel with flange disc Inconel 600)				N	5									
Others				Z	9									
<b>Thermowell type</b>														
Weld-in thermowell from bar stock material, acc. to DIN 43772, Form 4, diameter F2 = 24 mm				D	1									
Weld-in thermowell from bar stock material, acc. to DIN 43772, Form 4, quick response, diameter F2 = 18 mm (ABB-Form 4S)				D	2									
Flanged thermowell from bar stock material, acc. to DIN 43772, Form 4F, diameter F2 = 24 mm				D	3									
Flanged thermowell from bar stock material, acc. to DIN 43772, Form 4F, quick response, diameter F2 = 18 mm (ABB-Form 4FS)				D	4									
Weld-in thermowell from bar stock material, acc. to ABB standard, Form PW, diameter F2 = 32 mm				P	1									
Flanged thermowell from bar stock material, acc. to ABB standard, Form PF				P	2									
Screwed thermowell from bar stock material, acc. to ABB standard, Form PS				P	3									
Others				Z	9									

Continued on next page

Temperature Sensor SensyTemp TSP331	Variant digit No.										Code					
	1	2	3	4	5	6	7	8	9	0						
Catalog No. TSP331-																
<b>Process connection</b>																
Without process connection											Y	0	0			
Tapered thread 1/2 in NPT											S	0	4			
Tapered thread 3/4 in NPT											S	0	5			
Tapered thread 1 in NPT											S	0	6			
Flange DN 25 PN10 ... PN40, Form B1 acc. to EN 1092-1											F	0	3			
Flange DN 40 PN10 ... PN40, Form B1 acc. to EN 1092-1											F	0	4			
Flange DN 50 PN10 ... PN40, Form B1 acc. to EN 1092-1											F	0	5			
Flange 1 in 150 lbs., Form RF acc. to ANSI/ASME B16.5											F	0	7			
Flange 1 in 300 lbs., Form RF acc. to ANSI/ASME B16.5											F	0	8			
Flange 1.5 in 150 lbs., Form RF acc. to ANSI/ASME B16.5											F	1	1			
Flange 1.5 in 300 lbs., Form RF acc. to ANSI/ASME B16.5											F	1	2			
Flange 1.5 in 600 lbs., Form RF acc. to ANSI/ASME B16.5											F	1	3			
Flange 2 in 150 lbs., Form RF acc. to ANSI/ASME B16.5											F	1	5			
Flange 2 in 300 lbs., Form RF acc. to ANSI/ASME B16.5											F	1	6			
Flange 2 in 600 lbs., Form RF acc. to ANSI/ASME B16.5											F	1	7			
Others											Z	9	9			
<b>Extension tube length K</b>																
150 mm											K	1				
Variable extension tube length (price per each commencing 100 mm)											Z	9				
<b>Thermowell connection</b>																
Parallel thread M14 x 1.5											M	1				
Parallel thread M18 x 1.5											M	2				
Tapered thread 1/2 in NPT											N	1				
Nipple 1/2 in NPT - 1/2 in NPT											N	2				
Nipple-union 1/2 in NPT - 1/2 in NPT											N	3				
Others											Z	9				

Continued on next page

Temperature Sensor SensyTemp TSP331	Variant digit No.	1	7	21	22	23	24	25	26	27	28	Code				
	Catalog No.	TSP331-														
<b>Immersion length U</b> Without fixed immersion length				Y	0											
U = 130 mm				D	1											
U = 190 mm				D	2											
U = 340 mm				D	3											
U = 100 mm				P	1											
U = 150 mm				P	2											
U = 200 mm				P	3											
U = 250 mm				P	4											
U = 300 mm				P	5											
U = 350 mm				P	6											
Acc. to customer specification (price per each commencing 100 mm) (Thermowell type D3, D4)				Z	9											
Acc. to customer specification (price per each commencing 100 mm) (Thermowell type P1, P2, P3)				Z	9											
Acc. to customer specification (price per each commencing 100 mm) (Thermowell type P1, P2, P3, material Hastelloy C276)				Z	9											
<b>Thermowell length L</b>																
L = 110 mm, C = 65 mm				D	1											
L = 140 mm, C = 65 mm				D	3											
L = 200 mm, C = 65 mm				D	4											
L = 200 mm, C = 125 mm				D	5											
L = 260 mm, C = 125 mm				D	6											
L = 410 mm, C = 275 mm				D	7											
Acc. to ABB Standard (immersion length + 65 mm)				P	1											
Acc. to customer specification				Z	9											
<b>Measuring inset type</b>																
Resistance thermometer, basic application, measuring range -50 ... 400 °C								S	1							
Resistance thermometer, extended vibration resistance, measuring range -50 ... 400 °C								S	2							
Resistance thermometer, extended measuring range -200 ... 600 °C								D	1							
Thermocouple								T	1							
Others								Z	9							
<b>Sensor type and wiring</b>																
1 x Pt100, 2-wire										P	1					
1 x Pt100, 3-wire										P	2					
1 x Pt100, 4-wire										P	3					
2 x Pt100, 2-wire										P	4					
										P	4					
2 x Pt100, 3-wire										P	5					
										P	5					
2 x Pt100, 4-wire										P	6					
										P	6					
										K	1					
1 x Type K (NiCr-Ni)										K	2					
2 x Type K (NiCr-Ni)										J	1					
1 x Type J (Fe-CuNi)										J	2					
2 x Type J (Fe-CuNi)										N	1					
1 x Type N (NiCrSi-NiSi)										N	2					
2 x Type N (NiCrSi-NiSi)										Z	9					
Others																

Continued on next page

Temperature Sensor SensyTemp TSP331	Variant digit No.							Code								
	1 - 7	27	28	29	30	31	32					33	34			
Catalog No. <b>TSP331-</b>																
<b>Sensor accuracy</b>																
Standard accuracy EN 60751 class B										B	2					
Extended accuracy EN 60751 class A from -30 ... 350 °C										S	1					
Extended accuracy EN 60751 class A from -200 ... 600 °C										D	1					
Standard accuracy EN 60584 class 2										T	2					
Extended accuracy EN 60584 class 1										T	1					
High accuracy EN 60751 1/3 class B from 0 ... 100 °C										S	3					
Others										Z	9					
<b>Connection head</b>																
AGL / aluminium, screwed cover										L	1					
AGLH / aluminium, high cover, screwed										L	2					
AGLD / aluminium, screwed cover with display										L	4					
AGS / stainless steel, screwed cover										S	1					
AGSH / stainless steel, high cover, screwed										S	2					
AGSD / stainless steel, screwed cover with display										S	4					
Others										Z	9					
<b>Transmitter</b>																
Without transmitter, measuring inset with ceramic terminal block										Y	1					
Without transmitter, measuring inset with flying leads										Y	2					
TR04, fixed range, output signal 4 ... 20 mA																
2/3-wire circuit										R	1					
4-wire circuit										R	1					
TR04-Ex, fixed range, output signal 4 ... 20 mA																
2/3-wire circuit										R	2					
4-wire circuit										R	2					
TH01, programmable, output signal 4 ... 20 mA										P	1					
TH01-Ex, programmable, output signal 4 ... 20 mA										P	2					
TH02, programmable, output signal 4 ... 20 mA, HART										H	1					
TH02-Ex, programmable, output signal 4 ... 20 mA, HART										H	2					
TTH300, programmable, output signal 4 ... 20 mA, HART										H	4					
TTH300 (Ex-version), programmable, output signal 4 ... 20 mA, HART										H	5					
TF12, programmable, output PROFIBUS PA										F	1					
TF12-Ex, programmable, output PROFIBUS PA										F	2					
TF02, programmable, output FOUNDATION Fieldbus										F	3					
TF02-Ex, programmable, output FOUNDATION Fieldbus										F	4					
Others										Z	9					

**Additional ordering information**

Temperature Sensor SensyTemp TSP331	Code			
<b>Name plate</b> Stainless steel plate with TAG no.	T1			
<b>Certificates</b> TÜV certificate for functional safety SIL2 acc. IEC61508 Material monitoring with inspection certificate 3.1 acc. to EN 10204 for wetted parts Declaration of compliance with the order 2.1 acc. to EN 10204 Inspection certificate 3.1 acc. to EN 10204 for visual, dimensional and functional test Inspection certificate 3.1 acc. to EN 10204 for helium leak test Inspection certificate 3.1 acc. to EN 10204 for X-ray test Inspection certificate 3.1 acc. to EN 10204 for dye penetration test Inspection certificate 3.1 acc. to EN 10204 for pressure test on thermowell Inspection certificate 3.1 acc. to EN 10204 for sensor calibration 1 x Pt100 Inspection certificate 3.1 acc. to EN 10204 for sensor calibration 2 x Pt100 Inspection certificate 3.1 acc. to EN 10204 for sensor calibration 1 x thermocouple Inspection certificate 3.1 acc. to EN 10204 for sensor calibration 2 x thermocouple DKD sensor calibration 1 x Pt100, separate calibration certificate for each thermometer DKD sensor calibration 2 x Pt100, separate calibration certificate for each thermometer DKD sensor calibration 1 x thermocouple, separate calibration certificate for each thermometer DKD sensor calibration 2 x thermocouple, separate calibration certificate for each thermometer <b>Others</b>	CS <b>C2</b> C4 C6 C7 C8 C9 <b>CB</b> CD CE CF CG CH CJ CK CL CZ			
<b>Temperatures for sensor calibration</b> 0 °C / 32 °F 100 °C / 212 °F 400 °C / 752 °F 0 °C and 100 °C / 32 °F and 212 °F 0 °C and 400 °C / 32 °F and 752 °F 0 °C, 100 °C and 200 °C / 32 °F, 212 °F and 392 °F 0 °C, 200 °C and 400 °C / 32 °F, 392 °F and 752 °F As specified by customer (price per calibration point)	V1 V2 V3 V4 V5 V7 V8 V6			
<b>Temperatures for DKD calibration</b> 0 °C / 32 °F 100 °C / 212 °F 400 °C / 752 °F 0 °C and 100 °C / 32 °F and 212 °F 0 °C and 400 °C / 32 °F and 752 °F 0 °C, 100 °C and 200 °C / 32 °F, 212 °F and 392 °F 0 °C, 200 °C and 400 °C / 32 °F, 392 °F and 752 °F As specified by customer (price per calibration point)	D1 D2 D3 D4 D5 D7 D8 D6			

**Additional ordering information**

Temperature Sensor SensyTemp TSP331	Code			
<b>Thermowell options</b>				
Thermowell incl. tests and certificates acc. to NACE MR 0175	S8			
Thermowell clean for oxygen service	S9			
Others	SZ			
<b>Flange connection options</b>				
Flange facing with groove form C acc. to EN 1092-1	F1			
Flange facing with tongue form D acc. to EN 1092-1	F2			
Flange facing with RTJ surface acc. to ANSI/ASME B16.5	F3			
Flange full penetration welded	F4			
Others	FZ			
<b>Cable entry options</b>				
1 x 1/2 in NPT, without cable gland	U2			
2 x 1/2 in NPT, without cable gland	U5			
2 x M20 x 1.5, with plastic cable gland, cable diameter 5 ... 12 mm	U7			
2 x M20 x 1.5, with EEx-d cable gland, cable diameter 6.0 ... 7.5 mm	UC			
Others	UZ			
<b>Transmitter measuring range</b>				
-30 ... 60 °C	A1			
-20 ... 40 °C	A2			
0 ... 40 °C	A3			
0 ... 60 °C	A4			
0 ... 100 °C	A5			
0 ... 120 °C	A6			
0 ... 150 °C	A7			
0 ... 200 °C	A8			
0 ... 250 °C	AF			
0 ... 300 °C	AG			
0 ... 400 °C	AH			
0 ... 600 °C	AJ			
0 ... 800 °C	AK			
0 ... 1000 °C	AL			
0 ... 1200 °C	AM			
0 ... 1400 °C	AN			
0 ... 1600 °C	AP			
Others	AZ			

---

ABB has Sales & Customer Support  
expertise in over 100 countries worldwide.

[www.abb.com/temperature](http://www.abb.com/temperature)

The Company's policy is one of continuous product  
improvement and the right is reserved to modify the  
information contained herein without notice.

Printed in the Fed. Rep. of Germany (06.2007)

© ABB 2007

3KXT161002R1001



**ABB Limited**  
Salterbeck Trading Estate  
Workington, Cumbria  
CA14 5DS  
UK  
Tel: +44 (0)1946 830 611  
Fax: +44 (0)1946 832 661

**ABB Inc.**  
125 E. County Line Road  
Warminster, PA 18974  
USA  
Tel: +1 215 674 6000  
Fax: +1 215 674 7183

**ABB Automation Products GmbH**  
Borsigstr. 2  
63755 Alzenau  
Germany  
Tel: +49 551 905-534  
Fax: +49 551 905-555  
CCC-support.deapr@de.abb.com

DS/TSP3X1-EN Rev. A