

**EN**  
English

## Commissioning Instructions

### Head mounted Temperature Transmitter TTH300



**HART**  
FIELD COMMUNICATIONS PROTOCOL

**ABB**



# Head mounted Temperature Transmitter TTH300

## Commissioning Instructions - EN

CI/TTH300-EN

08.2007

Rev. A

### Manufacturer:

#### **ABB Automation Products GmbH**

Borsigstraße 2

63755 Alzenau

Germany

Tel.: +49 551 905-534

Fax: +49 551 905-555

CCC-support.deapr@de.abb.com

© Copyright 2007 by ABB Automation Products GmbH  
Subject to change without notice

This document is protected by copyright. It assists the user with the safe and efficient operation of the device. The contents may not be copied or reproduced in whole or in excerpts without prior approval of the copyright holder.

<b>1</b>	<b>Safety</b> .....	<b>3</b>
1.1	General Safety Information .....	3
1.2	Intended use.....	3
1.3	Technical limits.....	3
1.4	Personnel qualification .....	4
1.5	Electrical installation safety information .....	4
1.6	Operating safety information .....	4
1.7	Returning devices.....	4
1.8	Disposal.....	4
1.8.1	Information on WEEE directive 2002/96/EC (Waste Electrical and Electronic Equipment) .....	5
<b>2</b>	<b>Use in areas requiring ignition protection</b> .....	<b>6</b>
2.1	Approvals .....	6
2.2	Level of protection .....	6
2.3	Electrostatic charging.....	6
2.4	Ground.....	6
2.5	Interconnection .....	6
2.6	Configuration .....	6
2.7	Explosion-protection relevant information .....	6
<b>3</b>	<b>Installation</b> .....	<b>7</b>
3.1	Installation options.....	7
3.1.1	Installation in the cover of the connection head.....	7
3.1.2	Installation on a top-hat rail.....	7
3.1.3	Installation on the measuring inset .....	8
3.2	Installing the optional LCD display with control buttons.....	9
<b>4</b>	<b>Electrical connection</b> .....	<b>10</b>
4.1	Conducting material .....	10
4.2	Pin configuration.....	11
4.2.1	Sensor connection .....	11
4.3	Signal/supply connection.....	14
4.3.1	Standard application .....	14
4.3.2	Installation in ignition protection areas.....	17
4.3.3	Zone 1 (0).....	18
4.3.4	Zone 1 (20).....	19
4.3.5	Zone 2 .....	20
<b>5</b>	<b>Startup Operation</b> .....	<b>21</b>
<b>6</b>	<b>Appendix</b> .....	<b>21</b>
6.1	Additional documents.....	21

## 1 Safety

### 1.1 General Safety Information

The “Safety” chapter provides an overview of the safety aspects to be observed for the operation of the device.

The device is built based on state-of-the-art technology and is operationally safe. It was tested and left the factory in a proper state. The requirements in the manual as well as the documentation and certificates must be observed and followed in order to maintain this state for the period of operation.

The general safety requirements must be complied with completely during operation of the device. In addition to the general information, the individual chapters of the manual contain descriptions about processes or procedural instructions with specific safety information.

Only the observance of all safety information enables the optimal protection of personnel as well as the environment from hazards and the safe and trouble-free operation of the device.

### 1.2 Intended use

This device is intended for the following uses:

- To measure the temperature of fluid, pulpy or pasty substances and gases or resistance/voltage values.

The following items are included in the intended use:

- Read and follow the instructions in this manual.
- Observe the technical ratings (refer to the section “Technical data” or data sheet).

Repairs, alterations and enhancements or the installation of replacement parts is only permissible as far as described in the manual. Further actions must be verified with ABB Automation Products GmbH. Excluded from this are repairs performed by ABB-authorized specialist shops.

### 1.3 Technical limits

The device is designed for use exclusively within the stated values on the name plate and in the technical specifications (see “Technical Specifications” chapter and/or data sheet). These must be complied with accordingly, e.g.:

- The maximum operating temperature may not be exceeded.
- The permitted operating temperature may not be exceeded.
- The housing protection system must be observed.

## 1.4 Personnel qualification

The installation, commissioning and maintenance of the device may only be carried out through trained specialist personell authorized by the plant operator. The specialist personnel must have read and understood the manual and comply with its instructions.

## 1.5 Electrical installation safety information

The electrical connection may only be performed by authorized specialist personnel according to the electrical plans.

Observe the electrical connection information in the manual, otherwise the electrical protection can be affected.

The secure isolation of contact-dangerous electrical circuits is only guaranteed when the connected devices fulfil the requirements of the DIN VDE 0106 T.101 (basic requirements for secure isolation).

For secure isolation, run the supply lines separated from contact-dangerous electrical circuits or additionally isolate them.

## 1.6 Operating safety information

Before switching on, ensure that the specified environmental conditions in the “Technical Specifications” chapter and/or in the data sheet are complied with and that the power supply voltage corresponds with the voltage of the transmitter.

When there is a chance that safe operation is no longer possible, put the device out of operation and secure against unintended operation.

## 1.7 Returning devices

Use the original packaging or a suitably secure packaging for returning the device for repair or for recalibration. Include the properly filled out return form (see attachment) with the device.

According to EC guidelines for hazardous materials, the owner of hazardous waste is responsible for its disposal or must observe the following regulations for its shipping:

All delivered devices to ABB Automation Products GmbH must be free from any hazardous materials (acids, alkali, solvents, etc.).

## 1.8 Disposal

ABB Automation Products GmbH actively promotes environmental consciousness and has an operational management system in accordance with DIN EN ISO 9001:2000, EN ISO 14001:2004 and OHSAS 18001. Our products and solutions should have minimum impact on the environment and persons during manufacture, storage, transport, use and disposal.

This includes the environmentally friendly use of natural resources. Through its publications ABB conducts an open dialog with the public.

This product/solution is manufactured from materials that can be reused by specialized recycling companies.

**1.8.1 Information on WEEE directive 2002/96/EC (Waste Electrical and Electronic Equipment)**

This product/solution is not subject to the WEEE directive 2002/96/EC and relevant national laws (e.g., ElektroG in Germany).

Dispose of the product/solution directly in a specialized recycling facility and do not use the municipal garbage. Only privately used products may be disposed of in the municipal garbage according to the WEEE directive 2002/96/EC. Proper disposal prevents negative effects on people and the environment, and supports the reuse of valuable raw materials.

If it is not possible to dispose of old equipment properly, ABB Service can accept and dispose of returns for a fee.

### 2 Use in areas requiring ignition protection

Special regulations must be observed in explosion-protection zones for the auxiliary power connection, signal inputs/outputs and ground connection. Information on ignition protection in the separate chapters must be observed.



#### **Caution! Potential damage to parts!**

All parts must be installed in accordance with manufacturer information and relevant standards and regulations.

Startup and operation must comply with EN 600790-14 (Installation of equipment in potentially explosive atmospheres).

#### 2.1 Approvals

The approvals for use of the TTH300 temperature transmitter in explosion-protection areas can be found in the section "Approvals".

#### 2.2 Level of protection

The adapters for the model TTH300-E1 temperature transmitter and the HMI ignition-proof type A LC display must be installed with an IP20 level of protection in accordance with IEC 60529:1989.

#### 2.3 Electrostatic charging

When using the transmitter in zone 0, make sure you prevent unapproved electrostatic charging of the model TTH300-E1 temperature transmitter and the HMI ignition-proof type A LC display (observe warnings on the system).

#### 2.4 Ground

If for functional reasons, the intrinsically safe circuit has to be grounded by connection to the equipotential bonding system, it may only be grounded at a single location.

#### 2.5 Interconnection

If transmitters are operated in an intrinsically safe circuit, proof that the interconnection is intrinsically safe must be provided in accordance with DIN VDE 0165/08.98 (EN 60 079-14/1997 and IEC 60 079-14/1996). In general, intrinsically safe circuits require proof of interconnection.

#### 2.6 Configuration

TTH300-E1 temperature transmitters can be installed in the explosion-protection area in compliance with the proof of interconnection and directly in the explosion-protection area using approved handheld HART-terminals as well as by coupling an ignition-proof modem to the circuit outside the explosion-protection area.

#### 2.7 Explosion-protection relevant information

For additional information, refer to the section "Explosion-protection relevant information" or the data sheet.

### 3 Installation

#### 3.1 Installation options

There are three options for mounting the transmitter in the temperature sensor heads:

- in the cover of the connection head (without springs)
- on a top-hat rail
- directly on the measuring inset (spring mounted)

##### 3.1.1 Installation in the cover of the connection head

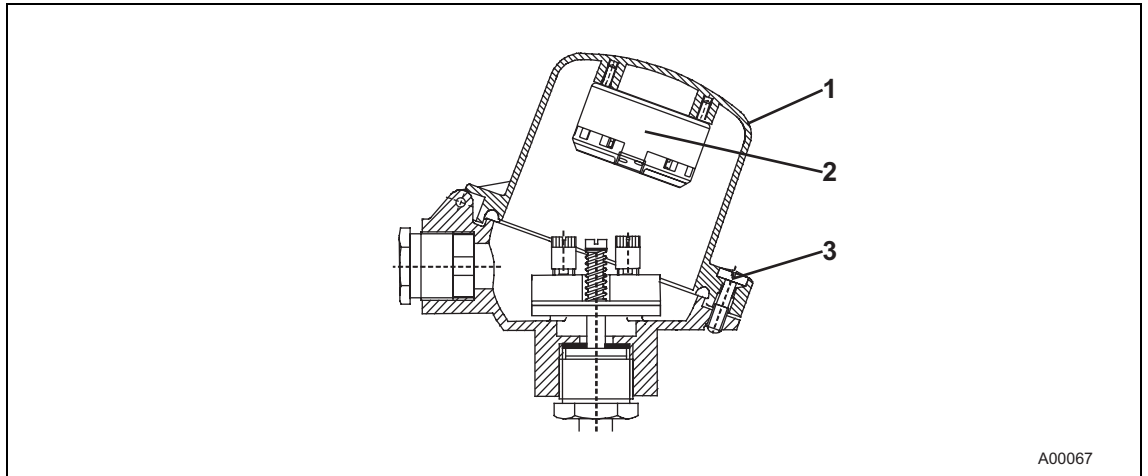

Fig. 1

1. Release the screw plug (3) for the cover of the connection head.
2. Open the cover (1).
3. Secure the transmitter (2) at the proper position on the cover, using the captive screws found in the transmitter.

##### 3.1.2 Installation on a top-hat rail

When mounted on a top-hat rail, the transmitter can be placed at a distance from the sensor in a housing suitable to the ambient conditions.

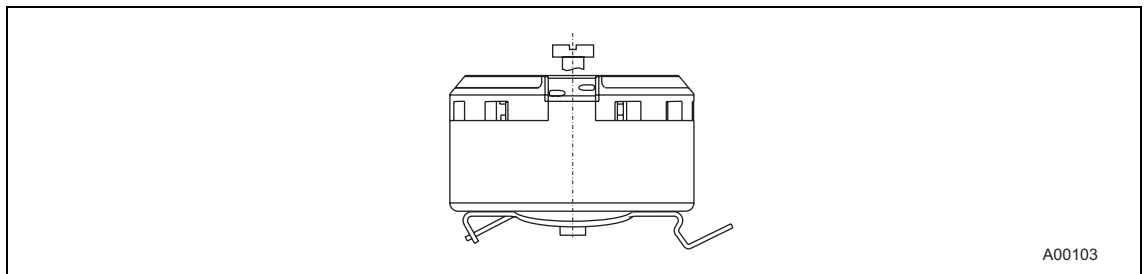

Fig. 2

For information on retrofitting, refer to the order matrix for TTH300 accessories.

## 3.1.3 Installation on the measuring inset

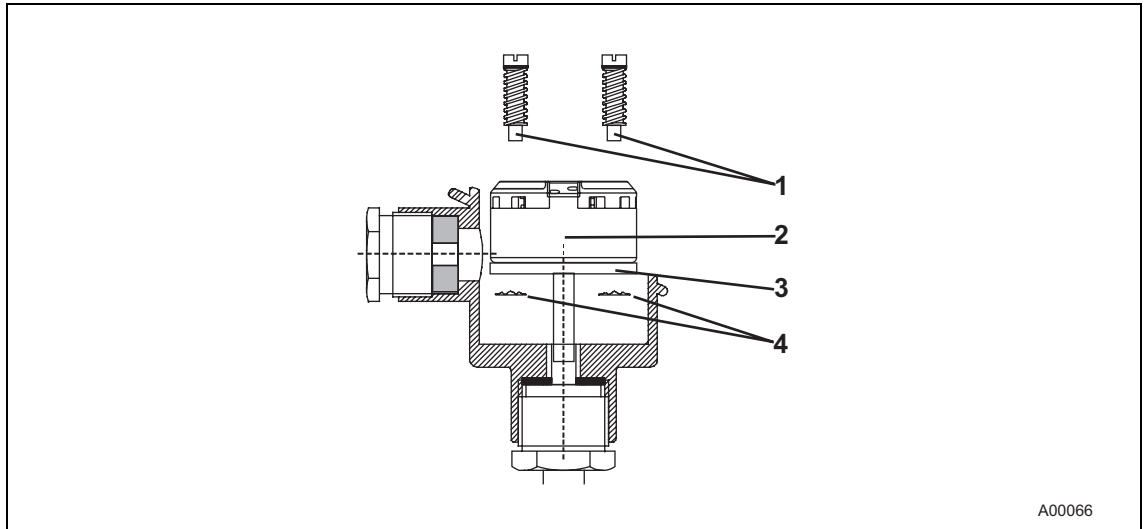

Fig. 3

**i****Note**

Before mounting the transmitter on the measuring inset, remove the ceramic block on the measuring inset and the captive screws in the transmitter.

To install the transmitter on the measuring inset, cambered toothed discs and the corresponding mounting screws are required; these must be ordered as separate accessories:

Measuring inset installation set (2 mounting screws, 2 springs, 2 toothed discs)

Order number: 215882

1. Remove the ceramic block from the measuring inset (3).
2. Remove the screws from the transmitter (2). Remove the sleeves from the screw holes and then remove the screws.
3. Insert new mounting screws (1) from above in the installation holes of the transmitter.
4. Place the cambered toothed discs (4) with curve facing upward on the downward protruding screw thread.
5. Connect the power supply cable to the transmitter according to connection diagram.
6. Place the transmitter in the housing on the measuring inset and secure it.

**i****Note**

The toothed discs between measuring inset and transmitter are straightened when the screws are tightened. This enables them to grip the mounting screws.

3.2 Installing the optional LCD display with control buttons

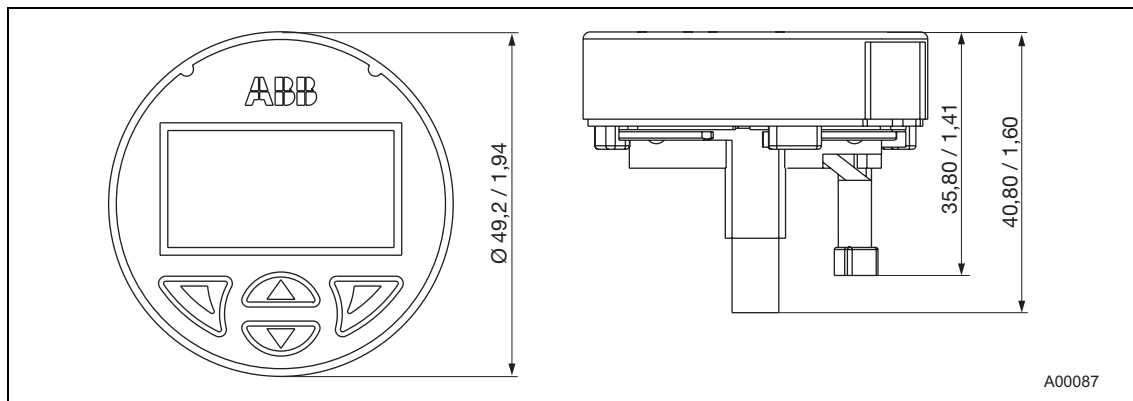

Fig. 4

The TTH300 is available as an Option with enabled HMI LCD display interface.  
 The optional activation of display functionality is available only when ordering the device.  
 The display is an accessory and must be ordered separately.

When connecting the sensor or supply line, remove the display for installation.

Carefully remove the LCD display from the inset for the transmitter. The LCD display is held firmly in place. You might have to use the tip of a screwdriver to pry loose the LCD display. Avoid mechanical damage.

No tools are required to insert the LCD display. Carefully insert the guide pins for the LCD display in the guide holes of the transmitter inset. Make sure the black connection sockets in the terminal fit in the transmitter inset. Then press in as far as it will go.

Make sure that the guide pins and the connection sockets are inserted fully.

The position of the LCD display can be adjusted to the installation position of the transmitter to ensure the display is readable. The LCD display has twelve positions that can be set in 30° increments.



**Caution - Potential damage to parts!**

Make sure the flat ribbon cable is not twisted or torn when rotating the LCD display.

Carefully turn the LCD display to the left to release it from its mount.

Use caution when positioning the LCD display.

Insert the LCD display back into the mount and turn it to the right until it snaps into place.

## 4 Electrical connection



### Warning – Electrical voltage risk!

Observe the corresponding instructions for the electrical installation. Only connect in dead-voltage state!

Since the transmitter has no switch-off elements, overvoltage protection devices, lightning protection or voltage separation capacity must be provided on the plant side.

Energy supply and signal are routed in the same line and are to be implemented as SELV or PELV circuit according to norm (standard version). In the ignition-proof version, the guidelines according to the ignition-proof norms are to be adhered to.

It must be checked whether the existing power supply corresponds with the specifications on the name plate and the technical specifications (see “Technical Specifications” chapter and/or data sheet).



### Note

The electrical connection is carried out with the transmitter in the installed state.

The signal cable wires must be provided with wire end sleeves.

The cross-head screws of the connection terminals are tightened with a size 1 screwdriver (3.5 mm or 4 mm).

### 4.1 Conducting material

- Standard conducting material must be used for the voltage supply cable.
- The maximum connectable conductor cross-section amounts to 1.5 mm<sup>2</sup>.



### Caution – Damage to parts!

The use of rigid conducting materials can lead to a wire break.

The connection cable must be flexible.

**4.2 Pin configuration**

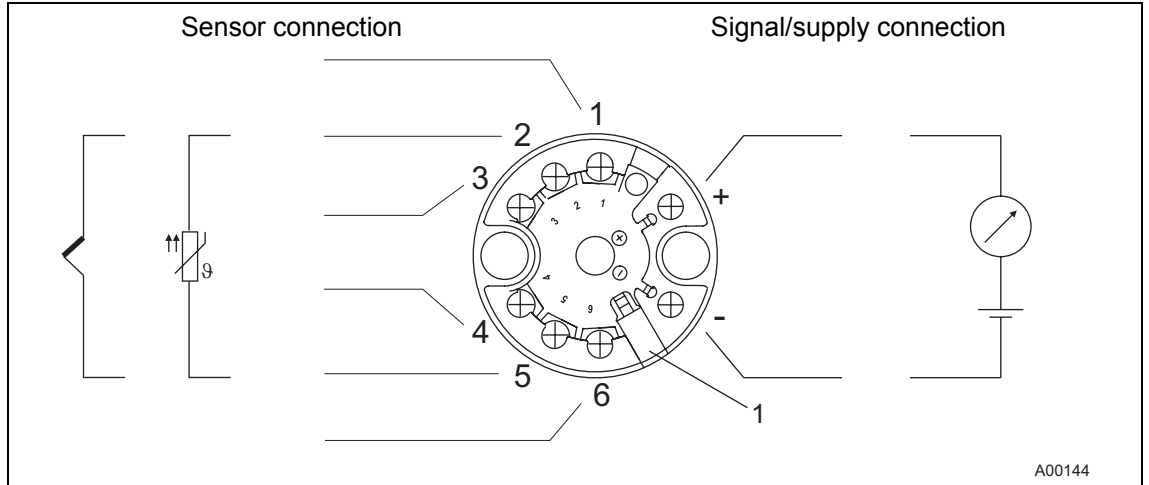

Fig. 5

- 1 HMI LCD display interface  
(activation is possible as an option only when ordering)

**4.2.1 Sensor connection**

Depending on the sensor model, a variety of line materials can be used for sensor connections. The integrated reference point makes it possible to directly connect thermal compensating lines.

## Electrical connection

### RTD resistance sensors

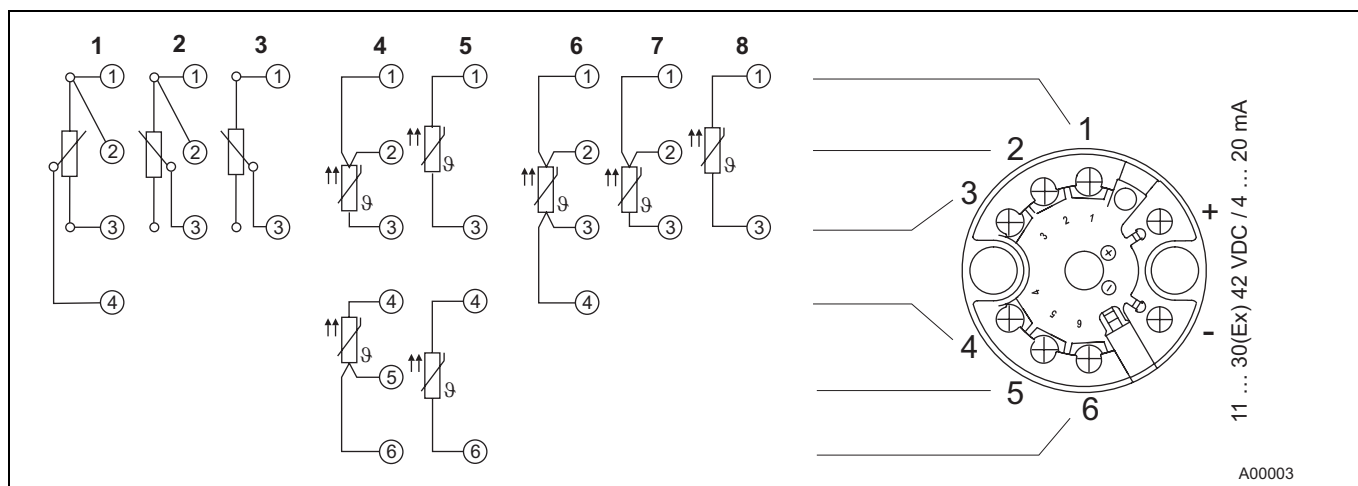

Fig. 6

### Potentiometer: 0 ... 500 $\Omega$ or 0 ... 5000 $\Omega$

- 1 Potentiometer, 4-wire circuit
- 2 Potentiometer, 3-wire circuit
- 3 Potentiometer, 2-wire circuit
- 4 2 x RTD, 3-wire circuit (sensor backup/redundancy, sensor drift monitoring, average value or differential temperature measurement)
- 5 2 x RTD, 2-wire circuit (sensor backup/redundancy, sensor drift monitoring, average value or differential temperature measurement)
- 6 RTD, 4-wire circuit
- 7 RTD, 3-wire circuit
- 8 RTD, 2-wire circuit

### Thermocouples/Voltages

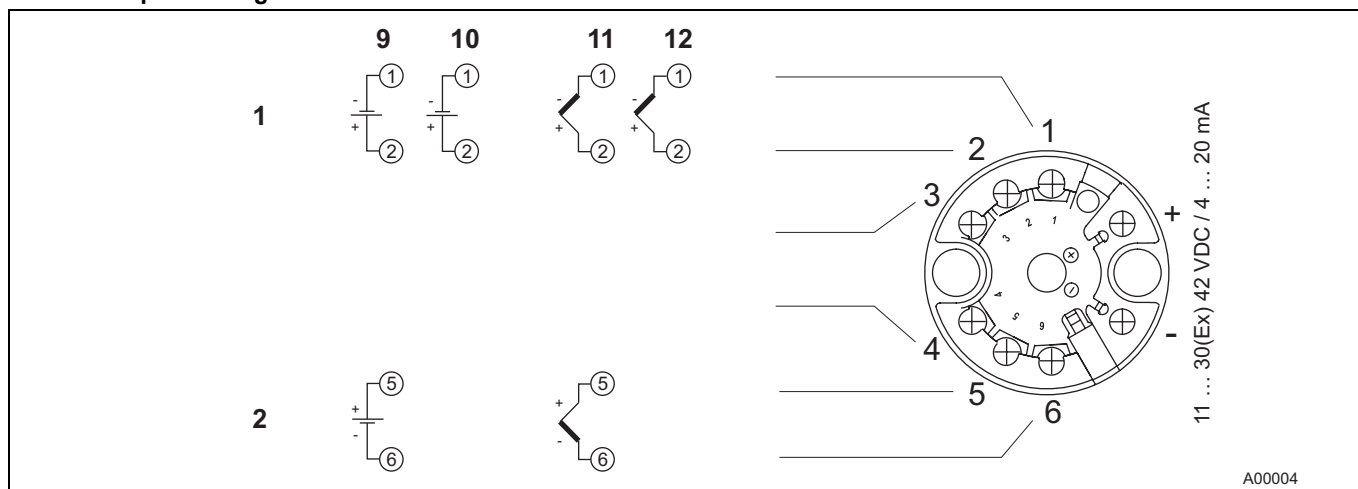

Fig. 7

- 1 Sensor 1
- 2 Sensor 2
- 9 2 x voltage measurement (sensor backup/redundancy, sensor drift monitoring, average value or differential temperature measurement)
- 10 Voltage measurement
- 11 2 x thermocouple (sensor backup/redundancy, sensor drift monitoring, average value or differential temperature measurement)
- 12 Thermocouple

**RTD/thermocouples configuration**

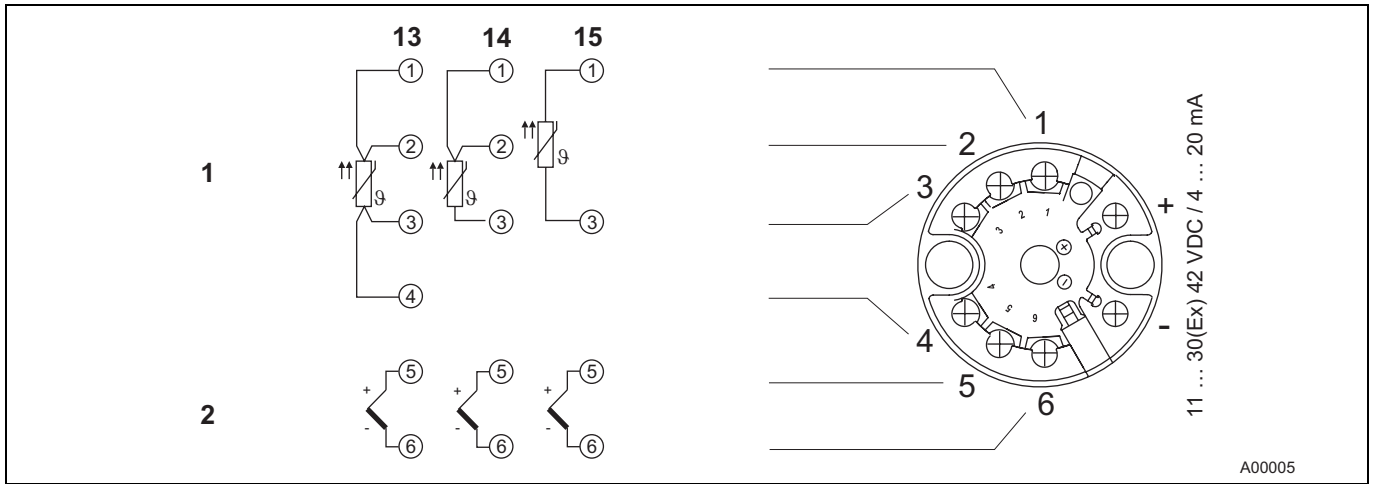

Fig. 8

- 1 Sensor 1
- 2 Sensor 2

- 13 1 x RTD, 4-wire circuit and thermocouple (sensor backup/redundancy, sensor drift monitoring, average value or differential temperature measurement)
- 14 1 x RTD, 3-wire circuit and thermocouple (sensor backup/redundancy, sensor drift monitoring, average value or differential temperature measurement)
- 15 1 x RTD, 2-wire circuit and thermocouple (sensor backup/redundancy, sensor drift monitoring, average value or differential temperature measurement)

4.3 Signal/supply connection

4.3.1 Standard application

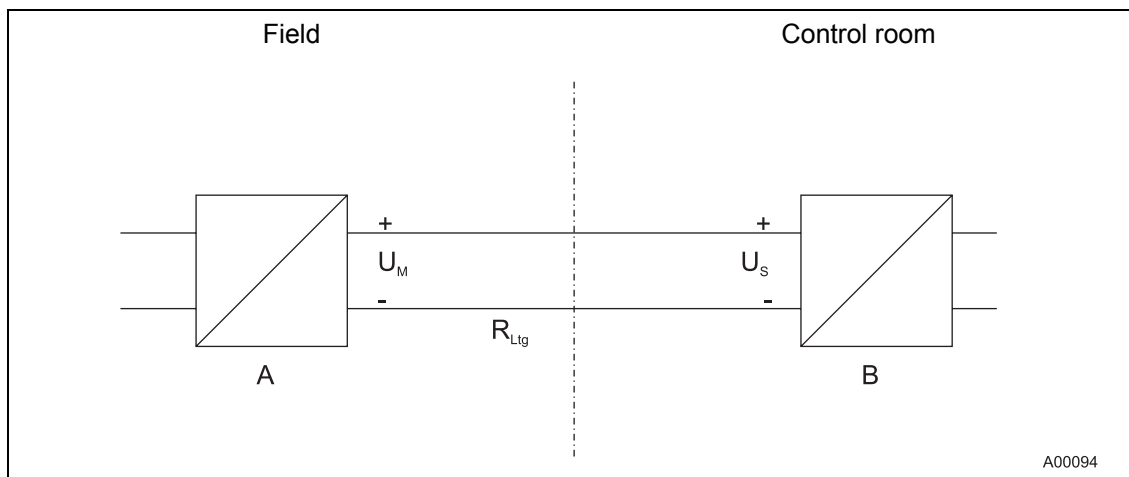

Fig. 9

A Transmitter

B Power supply / SPS input with supply

When connecting transmitters and power supplies, observe the following specification:

$$U_{Mmin} \leq U_{Smin} + 0.02A \times R_{Ltg}$$

Where

$U_{Mmin}$ : Minimum operating voltage of transmitter (refer to technical data for transmitter)

$U_{Smin}$ : Minimum supply voltage of power supply / SPS input

$R_{Ltg}$ : Line resistance between transmitter and power supply

For HART functionality, use power supplies or SPS input cards with HART mark. If this is not possible, the interconnection must have a resistance  $\geq 250 \Omega$  ( $< 1100 \Omega$ ).

The signal line can be connected with or without ground. When connecting the ground (minus side), make sure that only one side of the contact is connected to the equipotential bonding system.

**4.3.1.1 Standard application with HART functionality**

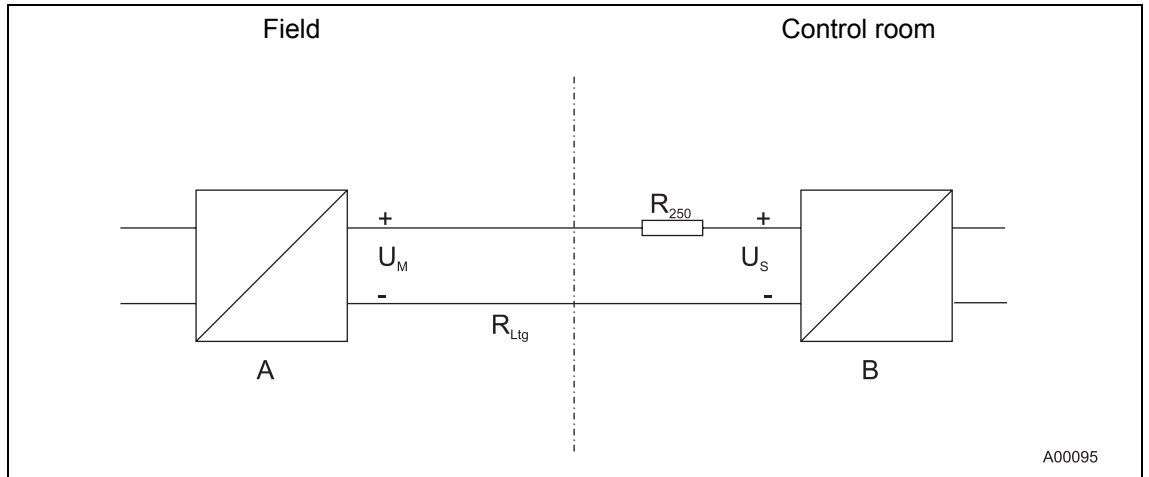

Fig. 10

A Transmitter

B Power supply / SPS input with supply

Adding resistance R250 increases the minimum supply voltage:

$$U_{Mmin} \leq U_{Smin} + 0.02A \times (R_{Ltg} + R_{250})$$

Where

$U_{Mmin}$ : Minimum operating voltage of transmitter (refer to technical data for transmitter)

$U_{Smin}$ : Minimum supply voltage of power supply / SPS input

$R_{Ltg}$ : Line resistance between transmitter and power supply

$R_{250}$ : Resistance for HART functionality

4.3.1.2 Electrical interconnection in explosion risk area

Special interconnections are required for use in hazardous areas depending on the safety requirements.

**Intrinsic safety**

The Power supply SPS inputs must have corresponding input protection circuits available in order to eliminate a hazard (spark formation). An interconnection inspection must be performed. For proof of the intrinsic safety, the electrical limit values are to be used as the basis for the prototype test certificates of the apparatuses (devices), including capacitance and inductivity values of the wires. The proof of the intrinsic safety is given if the following conditions are fulfilled with comparison of the limit values of the apparatus.

Transmitter (intrinsically safe apparatus)		Power supply / SPS input (related apparatus)
$U_i$	$\geq$	$U_o$
$I_i$	$\geq$	$I_o$
$P_i$	$\geq$	$P_o$
$L_i + L_c$ (cable)	$\leq$	$L_o$
$C_i + C_c$ (cable)	$\leq$	$C_o$

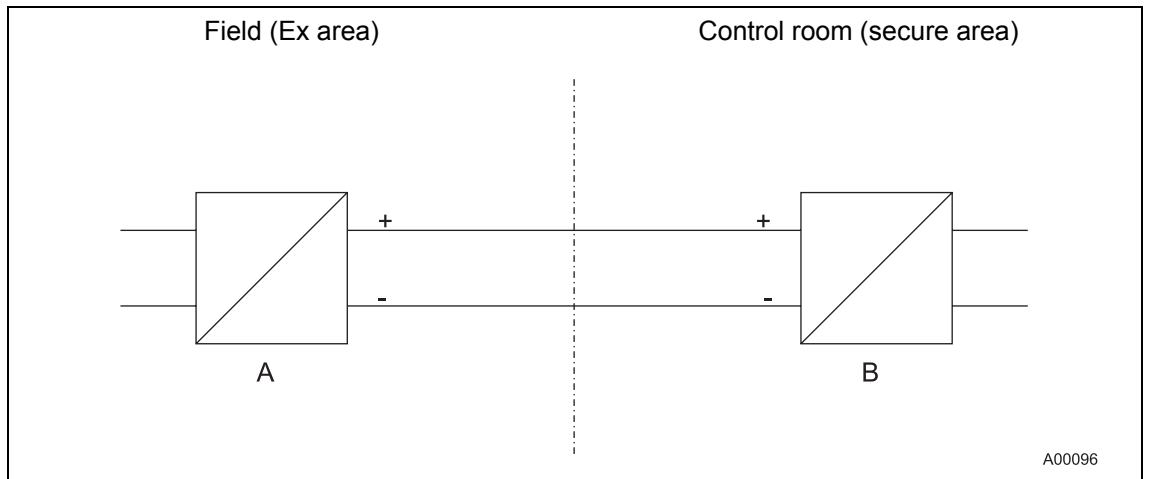

Fig. 11

A Transmitter

B Power supply SPS input



**Note**

Observe the “Technical specifications” and “Explosion-protection technical data” chapters (see data sheet and/or operating instructions).

**4.3.2 Installation in ignition protection areas**

Transmitters can be installed in a wide variety of industrial sectors. Systems that require ignition protection are divided into zones. As a result, different instruments are also required. For additional information, refer to the section “Explosion-protection relevant information” or the data sheet.

**4.3.2.1 Zone 0**

Transmitter design: II 1G EEx ia IIC T6

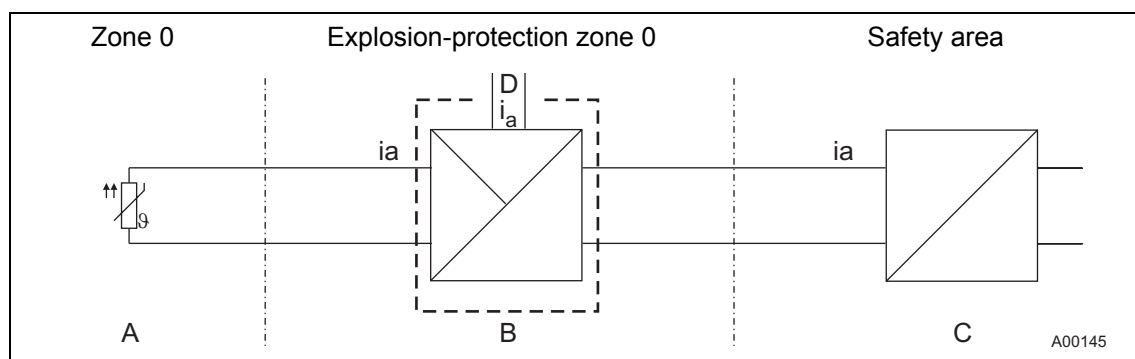

Fig. 12

- A Sensor
- B Transmitter in housing with IP20 level of protection
- C Power supply [EEx ia]
- D HMI interface for LCD displays (activation is possible as an option only when ordering)

For instruments in zone 0, the transmitter must be installed in its own housing with IP20 level of protection. The input for the power supply must be in [EEx ia] design.

When using the transmitter in zone 0, make sure you prevent electrostatic charging of the temperature transmitter (observe warnings on equipment).

The sensor must be used by the user in accordance with applicable ignition-protection standards.

4.3.3 Zone 1 (0)

Transmitter design: II 2 (1) G EEx [ia] ib IIC T6

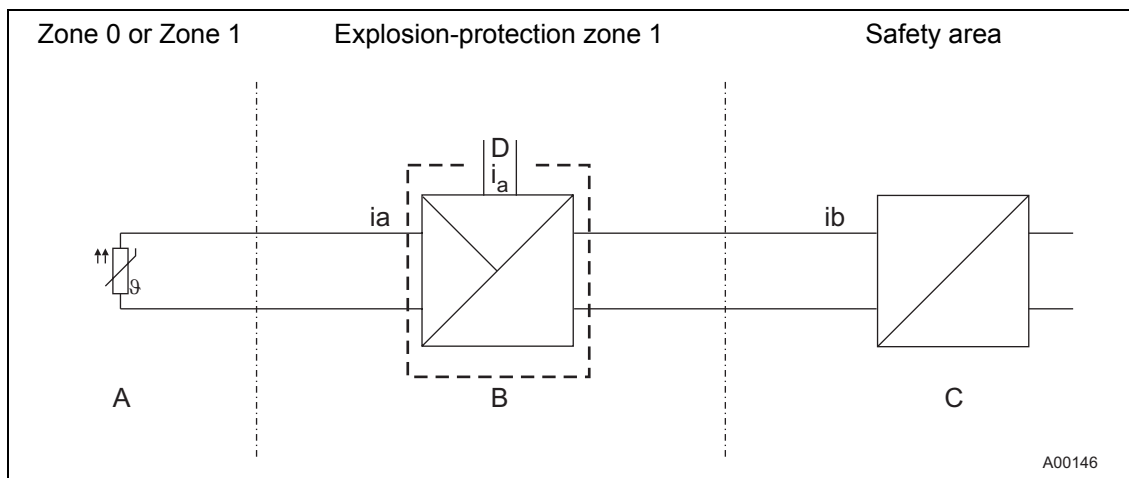

Fig. 13

- A Sensor
- B Transmitter in housing with IP20 level of protection
- C Power supply [EEx ib]
- D HMI interface for LCD displays (activation is possible as an option only when ordering)

For instruments in zone 1, the transmitter must be installed in its own housing with IP20 level of protection. The input for the power supply must be at a minimum in [EEx ib] design.

The sensor must be used by the user in accordance with applicable ignition-protection standards. It can be installed in zone 1 or zone 0.

**4.3.4 Zone 1 (20)**

Transmitter design: II 2G (1D) EEx [iaD] ib IIC T6

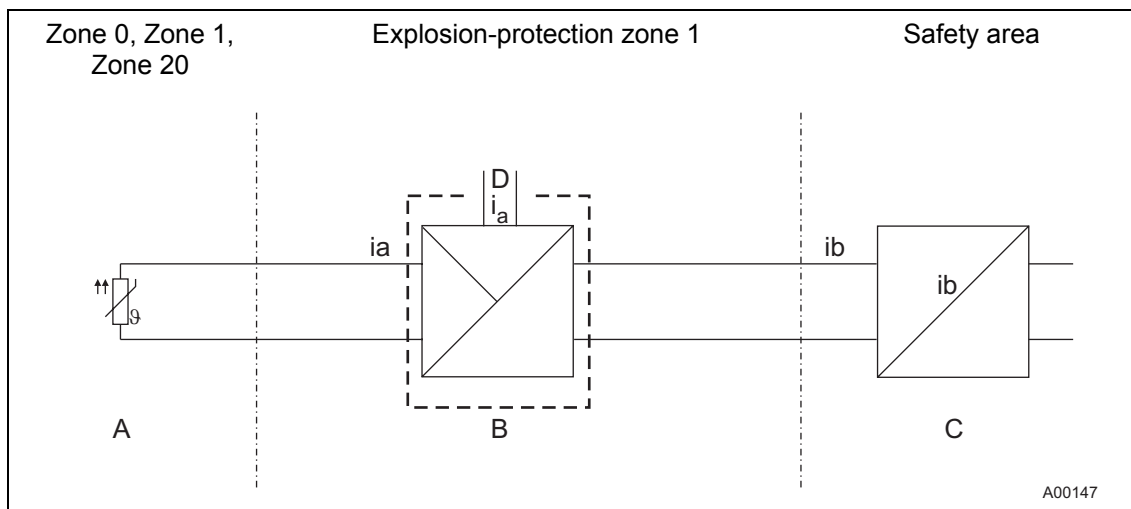

Fig. 14

- A Sensor
- B Transmitter in housing with IP20 level of protection
- C Power supply [EEx ib]
- D HMI interface for LCD displays (activation is possible as an option only when ordering)

For instruments in zone 1, the transmitter must be installed in its own housing with IP20 level of protection. The input for the power supply must be at a minimum in [EEx ib] design.

The sensor must be used by the user in accordance with applicable ignition-protection standards. It can be installed in zone 0, zone 1 or zone 20.

4.3.5 Zone 2

Transmitter design: II 3G EEx nA II T6

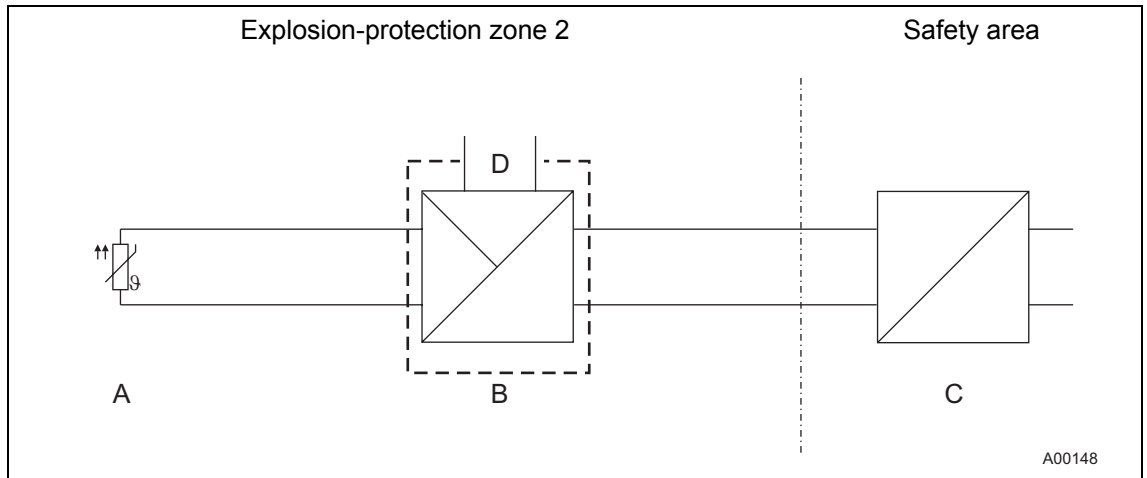

Fig. 15

- A Sensor
- B Transmitters in housing with IP54 level of protection
- C Power supply
- D HMI interface for LCD displays (activation is possible as an option only when ordering)

For instruments in zone 2, the transmitter must be installed in its own housing with IP54 level of protection.

Ensure that in case of a disturbance the supply voltage cannot exceed 40 % of the normal voltage.

## 5 Startup Operation



### Note

The transmitter is immediately ready for operation after mounting and installation of the connections. The parameters are set at the factory.

The connected wires must be checked for firm seating. Only firmly seated wires ensure full functionality.

## 6 Appendix



### Note

All documentation, declarations of conformity and certificates are available in the download area of ABB Automation Products GmbH.

[www.abb.com/temperature](http://www.abb.com/temperature)

### 6.1 Additional documents

- Operating Instructions (OI/TTH300)
- Data Sheet (DS/TTH300)

## Statement about the contamination of devices and components

The repair and/or maintenance of devices and components will only be performed when a completely filled out explanation is present.

Otherwise, the shipment can be rejected. This explanation may only be filled out and signed by authorized specialist personnel of the operator.

### Customer details:

Company:

Address:

Contact person:

Telephone:

Fax:

E-Mail:

### Device details:

Type:

Serial no.:

Reason for the return/description of the defect:

### Was this device used for working with substances which pose a threat or health risk?

Yes       No

If yes, which type of contamination (please place an X next to the applicable items)

biological	<input type="checkbox"/>	corrosive/irritating	<input type="checkbox"/>	combustible (highly/extremely combustible)	<input type="checkbox"/>
toxic	<input type="checkbox"/>	explosive	<input type="checkbox"/>	other toxic substances	<input type="checkbox"/>
radioactive	<input type="checkbox"/>				

Which substances have had contact with the device?

1.

2.

3.

We hereby certify that the devices/parts shipped were cleaned and are free from any dangerous or poisonous materials.

City, Date

Signature and company stamp



---

ABB provides expert and comprehensive consulting services in more than 100 countries worldwide.

[www.abb.com/temperature](http://www.abb.com/temperature)

ABB is continually improving its products. As a result, technical information in this document is subject to change.

Printed in the Fed. Rep. of Germany (08.2007)

© ABB 2007

3KXT231001R4401



**ABB Limited**

Salterbeck Trading Estate  
Workington, Cumbria  
CA14 5DS  
UK  
Tel: +44 (0)1946 830 611  
Fax: +44 (0)1946 832 661

**ABB Inc.**

125 E. County Line Road  
Warminster, PA 18974  
USA  
Tel: +1 215 674 6000  
Fax: +1 215 674 7183

**ABB Automation Products GmbH**

Borsigstr. 2  
63755 Alzenau  
Germany  
Tel: +49 551 905-534  
Fax: +49 551 905-555  
CCC-support.deapr@de.abb.com