



Member of the FM Global Group

FM Approvals
1151 Boston-Providence Turnpike
P.O. Box 9102 Norwood, MA 02062 USA
T: 781 762 4300 F: 781 762 9375 www.fmglobal.com

CERTIFICATE OF COMPLIANCE

HAZARDOUS (CLASSIFIED) LOCATION ELECTRICAL EQUIPMENT

This certificate is issued for the following equipment:

AM5433a2FCbcd. Variable Area Flowmeter.

XP / I / 1 / ABCD / T6 Ta=60°C; DIP / II / 1 / EFG / T6 Ta=60°C; Type 4X; IP67
IS / I, II, III / 1 / ABCDEFG / T4 Ta=70°C - SD-10-4074; Entity; NI / I / 2 / ABCD / T4 Ta=70°C

Entity Parameters:

Terminals 31/32: Vmax = 28 V, Imax = 110 mA, Pmax = 770 mW, Ci = 6 nF, Li = 204 µH

Terminals 41/42: Vmax = 15 V, Imax = 30 mA, Pmax = 115 mW, Ci = 3.6 nF, Li = 102 µH

a = Secondary design 1 or 2.

b = Material, Indicator housing-Meter tube 1, 2 or 3.

c = Meter tube design A, B, D, T or S.

d = Flange connection size(flange and tube) A, Q, P, R, B, N, C, D, E, F, S, T, U, or V.

AM5437a2FCbcd. Variable Area Flowmeter.

XP / I / 1 / ABCD / T6 Ta=60°C; DIP / II / 1 / EFG / T6 Ta=60°C; Type 4X; IP67
IS / I, II, III / 1 / ABCDEFG / T6 Ta=60°C - SD-10-4074; Entity; NI / I / 2 / ABCD / T5 Ta=40°C

Entity Parameters:

Terminals 41/42, 51/52: Vmax = 16 V, Imax = 20 mA, Ci = 80 nF, Li = 500 µH

a = Secondary design 1, 2, 3 or 4.

b = Material, Indicator housing-Meter tube 1, 2 or 3.

c = Meter tube design A, B, D, T or S.

d = Flange connection size(flange and tube) A, Q, P, R, B, N, C, D, E, F, S, T, U, or V.

AM5433a2FABcd. Variable Area Flowmeter.

XP / I / 1 / ABCD / T6 Ta=60°C; DIP / II / 1 / EFG / T6 Ta=60°C; Type 4X; IP67
IS / I, II, III / 1 / ABCDEFG / T4 Ta=70°C - SD-10-4074; Entity; NI / I / 2 / ABCD / T4 Ta=70°C

Entity Parameters:

Terminals 31/32: Vmax = 28 V, Imax = 110 mA, Pmax = 770 mW, Ci = 6 nF, Li = 204 µH

Terminals 41/42: Vmax = 15 V, Imax = 30 mA, Pmax = 115 mW, Ci = 3.6 nF, Li = 102 µH

a = Secondary design 1 or 2.

b = Material, Indicator housing-Meter tube 1, 2 or 3.

c = Meter tube design A, B, D, T or S.

d = Flange connection size(flange and tube) A, Q, P, R, B, N, C, D, E, F, S, T, U, or V.

AM5437a2FABcd. Variable Area Flowmeter.

XP / I / 1 / ABCD / T6 Ta=60°C; DIP / II / 1 / EFG / T6 Ta=60°C; Type 4X; IP67
IS / I, II, III / 1 / ABCDEFG / T6 Ta=60°C - SD-10-4074; Entity; NI / I / 2 / ABCD / T5 Ta=40°C

Entity Parameters:

Terminals 41/42, 51/52: $V_{max} = 16\text{ V}$, $I_{max} = 20\text{ mA}$, $C_i = 80\text{ nF}$, $L_i = 500\text{ }\mu\text{H}$

a = Secondary design 1, 2, 3 or 4.

b = Material, Indicator housing-Meter tube 1, 2 or 3.

c = Meter tube design A, B, D, T or S.

d = Flange connection size(flange and tube) A, Q, P, R, B, N, C, D, E, F, S, T, U, or V.

Equipment Ratings:

The Model AM5433 Variable Area Flowmeter is FM Approved for use as Explosionproof for Class I, Division 1, Groups A, B, C and D for an ambient temperature of 60°C with a Temperature Code of T6; Dust-Ignitionproof for Class II, Division 1, Groups E, F and G for an ambient temperature of 60°C with a Temperature Code of T6; Non-Incendive for Class I, Division 2, Groups A, B, C and D for an ambient temperature of 70°C with a Temperature Code of T4 and Intrinsically Safe for Class I/II/III, Division 1, Groups A, B, C, D, E, F and G : for an ambient temperature of 70°C with a Temperature Code of T4 when connected in accordance with ABB Drawing No. SD-10-1074 according to the Entity requirements listed below:

Entity Parameters:

Terminals 31/32: $V_{max} = 28\text{ V}$, $I_{max} = 110\text{ mA}$, $P_{max} = 770\text{ mW}$, $C_i = 6\text{ nF}$, $L_i = 204\text{ }\mu\text{H}$

Terminals 41/42: $V_{max} = 15\text{ V}$, $I_{max} = 30\text{ mA}$, $P_{max} = 115\text{ mW}$, $C_i = 3.6\text{ nF}$, $L_i = 102\text{ }\mu\text{H}$

The Model AM5437 Variable Area Flowmeter is FM Approved for use as Explosionproof for Class I, Division 1, Groups A, B, C and D for an ambient temperature of 60°C with a Temperature Code of T6; Dust-Ignitionproof for Class II, Division 1, Groups E, F and G for an ambient temperature of 60°C with a Temperature Code of T6; Non-Incendive for Class I, Division 2, Groups A, B, C and D for an ambient temperature of 40°C with a Temperature Code of T5 and Intrinsically Safe for Class I/II/III, Division 1, Groups A, B, C, D, E, F and G : for an ambient temperature of 60°C with a Temperature Code of T6 when connected in accordance with ABB Drawing No. SD-10-1074 according to the Entity requirements listed below:

Entity Parameters:

Terminals 41/42, 51/52: $V_{max} = 16\text{ V}$, $I_{max} = 20\text{ mA}$, $C_i = 80\text{ nF}$, $L_i = 500\text{ }\mu\text{H}$

The electrical enclosures used for the Models AM5433 and AM5437 Variable Flowmeters are FM Approved for Type 4X and IP67 applications.

FM Approved for:

ABB Automation Products GmbH
Dransfelder Strasse 2
37070 Gottingen, Germany

This certifies that the equipment described has been found to comply with the following Approval Standards and other documents:

Class 3600	1998
Class 3610	1999
Class 3611	2004
Class 3615	2006
Class 3810	2005
ANSI/NEMA 250	1991
IEC 60529	1989

Original Project ID: 3008432

Approval Granted: February 8, 2002

Subsequent Revision Reports / Date Approval Amended

Report Number	Date	Report Number	Date
051804	May 25, 2005		
070205	<i>MARCH 7, 2007</i>		

FM Approvals LLC

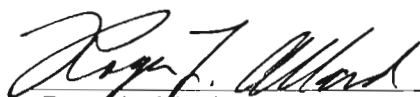

Roger L. Allard
Assistant Vice President

MARCH 7, 2007
Date

REV	AUTHORITY	REVISION DESCRIPTION	DWN BY	CHKD BY	APVD BY
1	068948	NOTES UPDATED WITH CSA INFO.	HAMPTON 15 APR 05	—	DW Madden 15 APR 05

THIS DOCUMENT IS CONTROLLED FOR PRODUCT SAFETY
DO NOT CHANGE
 WITHOUT PRIOR APPROVAL OF THE CERTIFICATIONS ADMINISTRATOR.

Intrinsic Safety
 Class I, Div 1, Groups A, B, C and D
 Class II, Div 1, Groups E, F and G and Class III

Entity Parameters:

Models AM5433 / AM5443 Ambient Temperature Range: -55°C to +70°C
 31/32 $V_{max} = 28V$ $I_{max} = 110mA$ $P_{max} = 770mW$ $C_i = 6nF$ $L_i = 204uH$
 41/42 $V_{max} = 15V$ $I_{max} = 30mA$ $P_{max} = 115mW$ $C_i = 3.6nF$ $L_i = 102uH$

Models AM5437 / AM5447 Ambient Temperature Range: IS -55°C to +60°C, NI -55°C to +40°C
 41/42, 51/52 $V_{max} = 16V$ $I_{max} = 20mA$ $C_i = 80nF$ $L_i = 500uH$

CAUTION:
SUBSTITUTION OF COMPONENTS MAY IMPAIR INTRINSIC SAFETY.
DO NOT DISCONNECT EQUIPMENT UNLESS POWER HAS BEEN SWITCHED OFF OR THE AREA IS KNOWN TO BE NON-HAZARDOUS.

Notes:

- The Intrinsic Safety Entity concept allows the interconnection of two FM and CSA Approved Intrinsically safe devices with entity parameters not specifically examined in combination as a system when:
 U_o or V_{oc} or $V_t \leq V_{max}$, I_o or I_{sc} or $I_t \leq I_{max}$, C_a or $C_o \geq C_i + C_{cable}$, L_a or $L_o \geq L_i + L_{cable}$, $P_o \leq P_i$.
- Dust-tight conduit seal must be used when installed in Class II and Class III environments.
- Control equipment connected to the Associated Apparatus must not use or generate more than 250 Vrms or Vdc.
- Installation should be in accordance with ANSI/ISA RP12.6 "Installation of Intrinsically Safe Systems for Hazardous (Classified) Locations" and the National Electrical Code® (ANSI/NFPA 70) Sections 504, 505 and CEC.
- The configuration of associated Apparatus must be Factory Mutual Research and CSA Approved under Entity Concept.
- Associated Apparatus manufacturer's installation drawing must be followed when installing this equipment.
- No revision to drawing without prior Factory Mutual Research and CSA Approval.
- Use shielded twisted pair cable ONLY (as shown above).

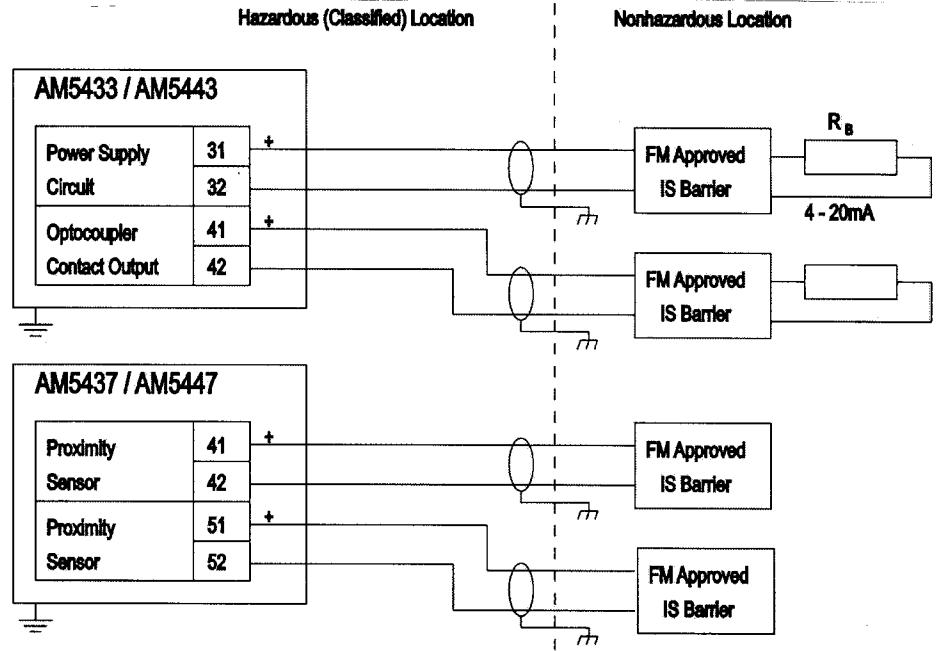

I. S. CONTROL DRAWING
 AM54



DWN	E. HAMPTON 10 JULY 03	ENGR		Q/E		PART NUMBER	REV
CHKD		MOD	AM54	M/E		SD-10-4074	1
SUPV		AUTH	DP1020-15-02				
REF DWG		B/M		SCALE - NONE	DRAWING NUMBER		