

Head mounted Temperature Transmitter TH02/TH02-Ex

HART programmable,
Pt 100 (RTD), thermocouples,
electrical isolation

■ Input

- Resistance thermometer (2-, 3-, 4-wire circuit)
- Thermocouples
- Resistance remote signalling unit (0...5000 Ω)
- Voltages, mV (-125...+1200 mV)

■ Output

- 2 wire technique
- 4...20 mA, HART signal

■ Electrical isolation (I/O)

■ Measured error 0.1 K

■ Customer-specific linearization

- 32 tie points

■ Continuous sensor and self-monitoring

- Parameter saved permanently in EEPROM
- Monitoring of data integrity every 10 s
- Wire break monitoring in acc. with NAMUR NE 89

■ Substitution strategy in case of error (NE 43)

■ Approvals for explosion protection

- Intrinsically safe
 - ⊕ II 2 (1) G EEx [ia] ib IIC T6, mount in zone 1
 - ⊕ II 3 G EEx n A II T6, mount in zone 2

■ Input functionality

(absolute, differential, average value)

■ EMC acc. to EN 50082-2 and NE 21

■ Parameterization

- Device Management Tool: DSV4xx (SMART VISION)
- Hand held terminals:
DHH691 (691 HT), STT04, HC275, FC375
- CoMeter (HART configurator/LC display)



Excellent long term stability
Temperature linear output signal
Enhanced self diagnostics

ABB

Technical data

Output

Output signal (temperature linear)

4...20 mA

Residual ripple (peak-to-peak)

< 0.3 %

Current consumption

< 3.6 mA

Maximum output current

23.6 mA

Parameterizable current error signal

Underranging/underranging value 3.6...4 mA
OVERRANGING/OVERRANGING value 20...23.6 mA
Default value (acc. to NE43) 3.6 or > 21 mA

Damping

$t_{63} = 0...30$ s

Input

Resistance

Resistance thermometer (IEC 751, JIS, SAMA)

$n \cdot Pt\ 100/Ni\ 100$ to $Pt\ 1000/Ni\ 1000$; Cu
($n = 0.1, 0.2, 0.5, 1, 1.2, 2, 3...10$)
Min. measuring span 15 K/50 K

Resistance

0...500 Ω /0...5000 Ω
Min. measuring span 5 Ω /50 Ω

Maximum line resistance ($R_{w\max}$) per core

2, 3, 4 wire 7.5 Ω , 10 Ω , 50 Ω

Measuring current

300 μ A

Sensor short-circuit

< 5 Ω (for RTD)

Sensor break (temperature/resistance measurement 2, 3, 4 wire)

Measuring range 0... 500 Ω > 530 Ω
Measuring range 0...5000 Ω > 5.3 k Ω

Sensor wire break monitoring in accordance with NAMUR NE 89

Sensor wire break detection
3 wire resistance measurement > 35 Ω
4 wire resistance measurement > 3.7 k Ω

Input filter

50/60 Hz

Thermocouples/Voltages

Types

B, E, J, K, L, N, R, S, T, U

Voltages

-125 mV...+ 125 mV
-125 mV...+1200 mV

Minimum measuring span

2 mV/50 mV

Sensor wire break monitoring in accordance with NAMUR NE 89

Pulsed with 1 μ A outside of the measuring interval
Monitoring disconnectible
Thermocouple measurement > 5 k Ω
Voltage measurement > 5 k Ω

Input filter

50/60 Hz

Internal reference junction

Pt 100, via software switchable (no jumper necessary)

Input element		Measuring range	Min. measuring span
Standard	Sensor		
IEC 584-1	Thermocouple type B	250...+1820 °C (+482...+3308 °F)	235 °C (423 °F)
	Thermocouple type E	-250...+1000 °C (-418...+1832 °F)	30 °C (54 °F)
	Thermocouple type J	-210...+1200 °C (-346...+2192 °F)	37 °C (67 °F)
	Thermocouple type K	-250...+1372 °C (-418...+2502 °F)	54 °C (98 °F)
	Thermocouple type R	- 50...+1768 °C (- 58...+3215 °F)	171 °C (308 °F)
	Thermocouple type S	- 50...+1768 °C (- 58...+3215 °F)	193 °C (348 °F)
	Thermocouple type T	-200...+ 400 °C (-328...+ 752 °F)	50 °C (90 °F)
DIN 43710	Thermocouple type U	-200...+1350 °C (-328...+2462 °F)	60 °C (108 °F)
	Thermocouple type L	-200...+ 900 °C (- 76...+ 482 °F)	36 °C (65 °F)
IEC 751; JIS; SAMA ¹⁾ 2, 3 and 4 wire	Resistance thermometer Pt 100	-200...+ 850 °C (-328...+1562 °F)	15 °C (28 °F)
	Resistance thermometer Pt 1000	-200...+ 850 °C (-328...+1562 °F)	50 °C (90 °F)
DIN 43760 2, 3 and 4 wire	Resistance thermometer Ni 100	- 60...+ 250 °C (- 76...+ 482 °F)	8 °C (15 °F)
	Resistance thermometer Ni 500	- 60...+ 250 °C (- 76...+ 482 °F)	15 °C (28 °F)
Resistance	Ω	0...500 Ω /0...5000 Ω	5 Ω /50 Ω
Voltage	mV	-125 mV...+ 125 mV	2 mV
		-125 mV...+1200 mV	50 mV

¹⁾ IEC 751 a = 0.00385, JIS a = 0.003916, SAMA a = 0.003902

Power supply (poling protected)

Supply voltage

Non-Ex-application $U_s = 8.5...30$ V DC
For Ex-Application, max. $U_i = 8.5...29.4$ V DC
2 wire methode: power supply wires = signal wires

Influence of supply voltage

< 0.05 %/10 V

maximum residual ripple

≤ 1 % U_s (< 500 Hz)

Power demand of indicators (only with AGLHD head)
(Power demand of transmitter and indicator have to be added)

Digital indicator

$U_{sd} = 2$ V DC

CoMeter (HART configurator/LC display)

$U_{sd} = 2.9$ V DC

Maximum load

$$R(k\Omega) = \frac{(U_{smax} - U_{smin})}{23.6}$$

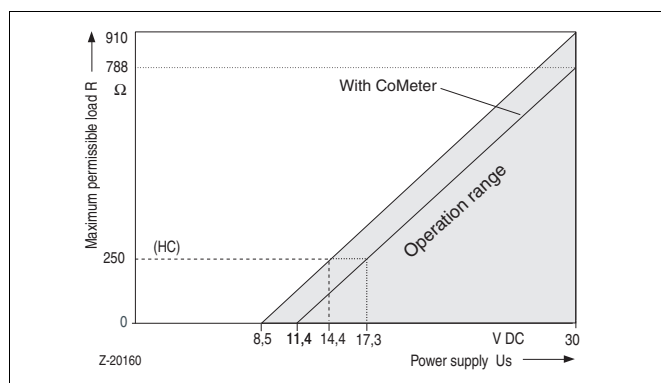

General characteristics

Output signal refreshment rate²⁾

Pt 100 0.4 s (Input signal change < 0.25 K/s)
Thermocouples 0.2 s (Input signal change < 2.5 K/s)

Vibration resistance

Vibration in operation 2 g acc. to DIN IEC 68T.2-6
Resistance to shock acc. to DIN IEC 68T.2-27

Electrical isolation (I/O)

1.5 kV AC (60 s)

Long-term drift

≤ 0.02 % per annum (ambient temperature < 60 °C)
≤ 0.05 % per annum (ambient temperature < 85 °C)

Environment conditions

Ambient temperature range: -40...85 °C

Transport and storage temperature

-40...100 °C

Relative humidity

< 100 % (100 % humidity with isolated terminals only)

Condensation: Permitted

Mechanical construction

Dimensions

Confer dimensional drawing

Weight: 55 g

Housing material

Polycarbonat
black (Non-Ex-type)
blue (Ex-type)

Electrical connection

Terminals, pluggable

2.5 mm², screw terminals (stainless steel screws)

²⁾ In case of an input signal change > 0.25 K/s for Pt 100 or > 2.5 K/s for thermocouples a measured value plausibility check is performed.

Characteristics at rated conditions

According to IEC 770 (related to 25 °C)¹⁾

Accuracy:		
General values		
Input type	Absolute accuracy	Temperature coefficient
All	≤ ± 0.05 % of span	≤ ± 0.005 % of span / °C
Basic values		
Input type	Absolute accuracy	Temperature coefficient
Pt 100 and Pt 1000	≤ ± 0.1 °C	≤ ± 0.005 % of progr. span / °C
Ni 100	≤ ± 0.1 °C	≤ ± 0.005 % of progr. span / °C
Lin. R: 500 Ω / 5 KΩ	≤ ± 0.040 Ω / ± 0.080 Ω	≤ ± 0.005 % of progr. span / °C
Volt: -125 mV...+125 mV /1250 mV	≤ ± 20 μV	≤ ± 0.005 % of progr. span / °C
TC type: E, J, K, L, N, T, U	≤ ± 0.5 °C	≤ ± 0.005 % of progr. span / °C
TC type: B, R, S, W3, W5	≤ ± 2.5 °C	≤ ± 0.005 % of progr. span / °C
EMC immunity influence	≤ ± 0.1 % of span	
Extended EMC immunity: NAMUR NE 21, A criterion, burst	≤ ± 1 % of span	

¹⁾ Percentage related to set measuring span, specified values corresponds to 3 σ (Gaussian normal distribution)

Explosion protection

Intrinsically safe

Zone 1

Marking Ⓔ II 2 (1) G EEx [ia] ib IIC T6
EC-Type-Examination certificate PTB 99 ATEX 2139 X
Temperature class T6/T5/T4 50 °C/65 °C/85 °C

Supply circuit	Output [ib]	Input [ia]
Max. voltage	$U_i = 29.4 \text{ V}$	$U_o = 5.6 \text{ V}$
Short-circuit current	$I_i = 130 \text{ mA}$	$I_o = 1.5 \text{ mA}^{(3)}$
Max. power	$P_i = 0.8 \text{ W}$	$P_o = 20 \text{ mW}$
Internal inductance	$L_i = 220 \text{ } \mu\text{H}$	$L_o = 1 \text{ mH}$
Internal capacitance	$C_i = 15 \text{ nF}$	$C_o = 1.55 \text{ } \mu\text{F}$

³⁾ See 1. supplement PTB 99 ATEX 2139 X

Zone 2

Marking Ⓔ III G EEx n A II T6
Conformity statement PTB 99 ATEX 2216 X
Temperature class T6/T5/T4 50 °C/65 °C/85 °C

Canadian Standards Association and Factory Mutual

Intrinsically Safe

FM Class I, Div. 1, Groups A, B, C, D T6
Class I, Zone 0, Group IIC T6
CSA Class I, Div. 1 and Div. 2, Groups A, B, C, D T6
Class I, Zone 0, Group IIC T6
(Class II Groups E, F, G; Class III if build in BUZH-, AGL- or AGLH head)

Nonincendive

FM Class I, Div. 2, Groups A, B, C, D, T6
CSA Class I, Div. 2, Groups A,B,C,D T6
(Class II, Groups E, F, G; Class III if build in BUZH-, AGL- or AGLH head)

Communication/parameterization

Hand held terminal HHT

DHH691 (691 HT), STT04, HC275, FC375

CoMeter

Hart configurator and LC display

Device Management Tool

DSV4xx (SMART VISION)

FDT/DTM technology

Software connection

AMS (from version 5 without additional drivers)

Parameter

Sensor type, error signalling, measuring range, general characteristics (i. e. TAG number), damping, signal simulation of output

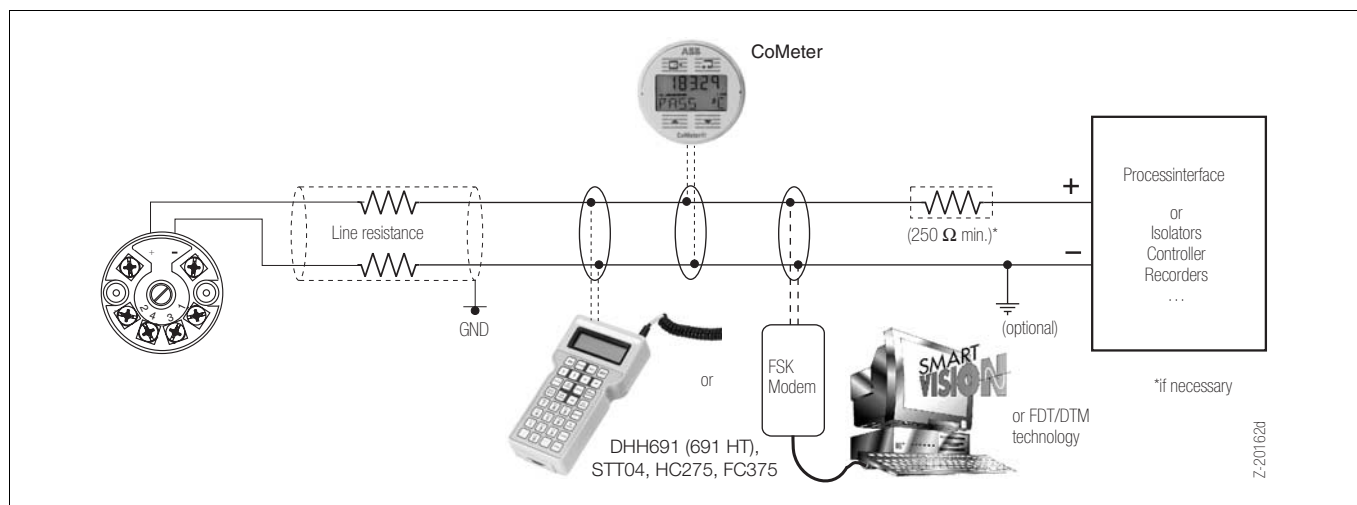

Connection diagram

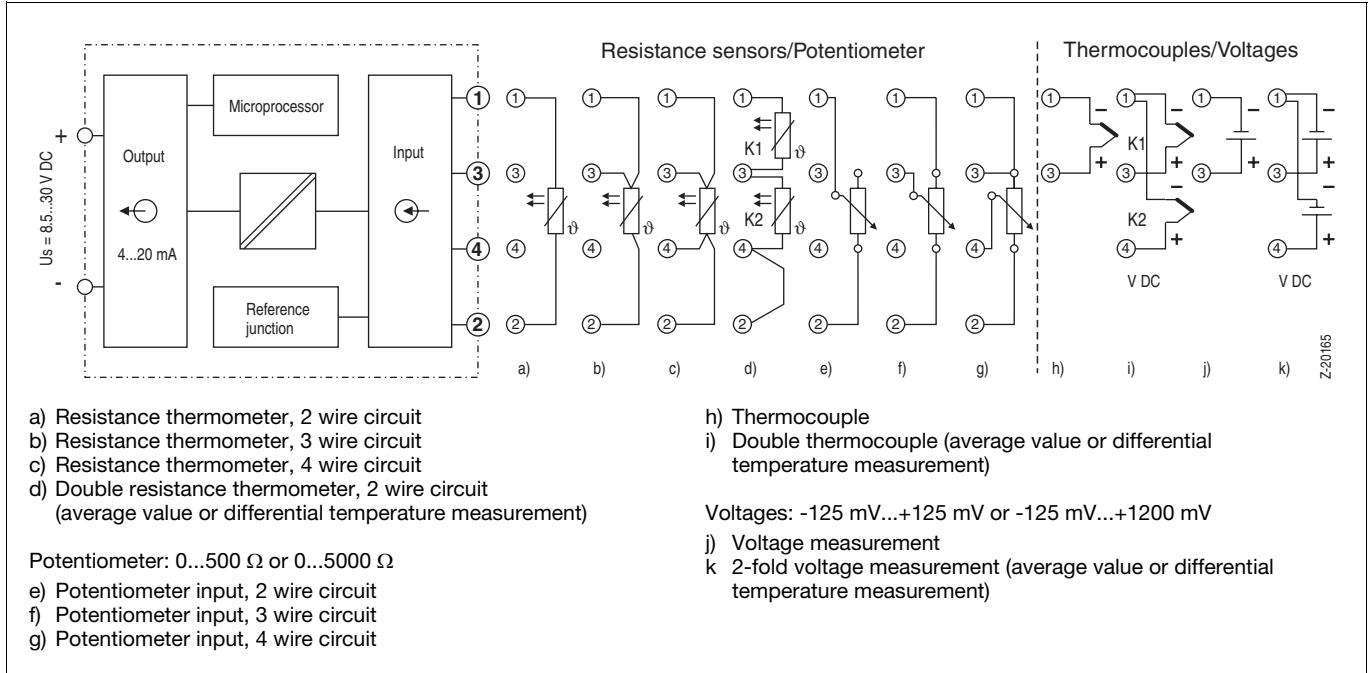

Dimensional diagram (dimensions in mm)

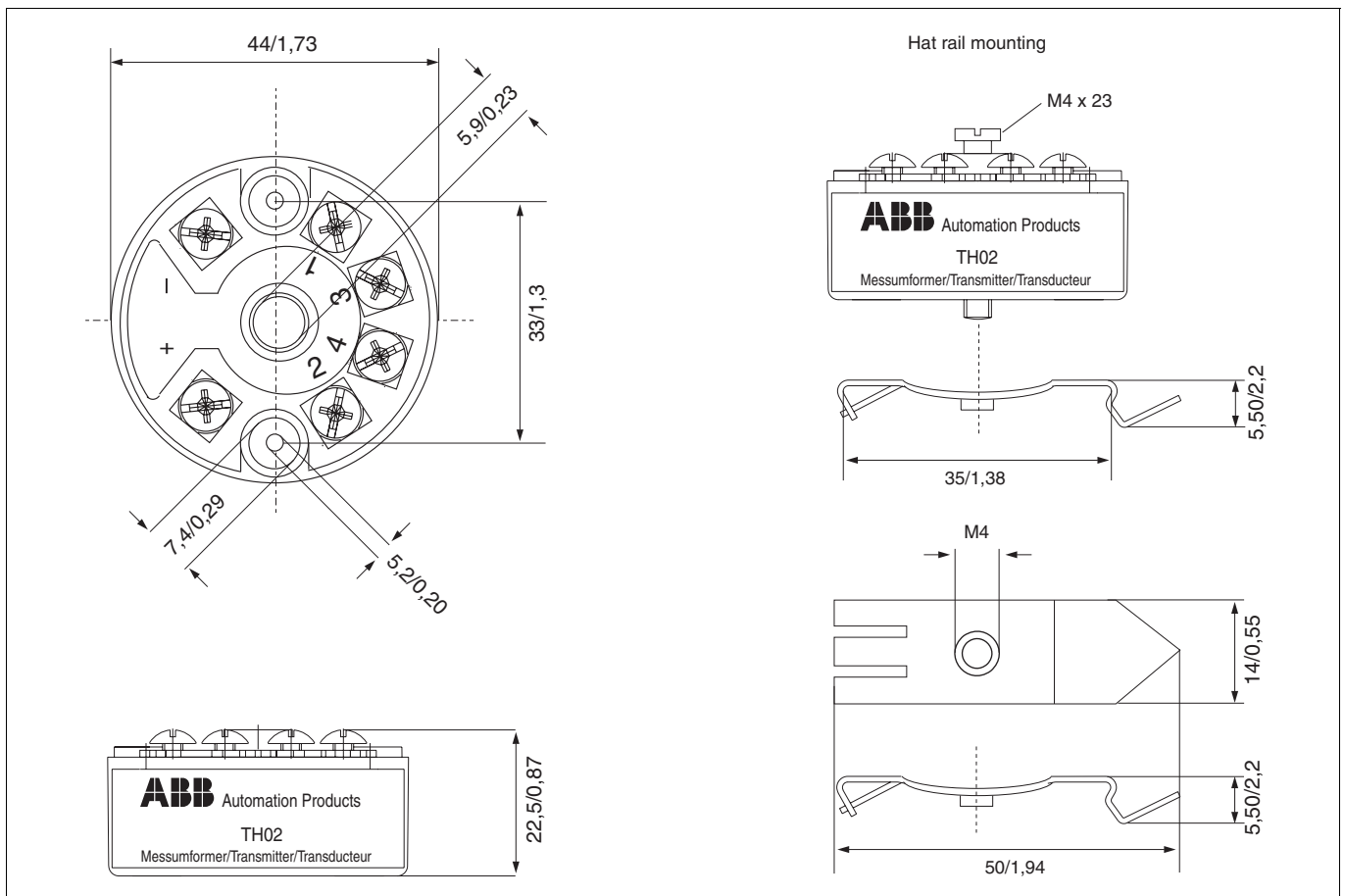

Ordering information

Head mounted Temperature Transmitter		Variant digit No.	1-7	8	9	10			
TH02 / TH02-Ex		Catalog No.	V11518-						
Explosion Protection									
TH02	without explosion protection					1			
TH02	metrological approval Russia					2			
TH02	metrological approval Kazakhstan					3			
Type of protection: intrinsically safe									
TH02-Ex	ATEX	Zone 1: II 2 (1) G EEx [ia]ib IIC T6				5			
TH02-Ex N	ATEX	Zone 2: II 3 G EEx n A II T6				N			
TH02-Ex	FM	IS Class I, Div. 1, Groups A, B, C, D T6, Class I, Zone 0, Group IIC T6				7			
TH02-Ex	CSA	IS Class I, Div.1 and Div. 2, Groups A, B, C, D T6, Class II, Groups E, F, G (Class III if built in BUZH head, AGL head or AGLH head) Nonincendive. Class I, Div. 2, Groups A, B, C, D T6, Class II, Groups E, F, G (Class III if built in BUZH head, AGL head or AGLH head)				9			
TH02-Ex N	FM	Nonincendive. Class I, Div. 2, Groups A, B, C, D T6				M			
TH02-Ex	GOST-Ex + metrological approval Russia	Zone 0: 0 Ex ia IIC T6				R			
TH02-Ex N	GOST-Ex + metrological approval Russia	Zone 2: 2 Ex nA II T6				U			
TH02-Ex	GOST-Ex + metrological approval Kazakhstan	Zone 0: 0 Ex ia IIC T6				V			
TH02-Ex	NEPSI	Zone 1: Ex [ia]ib IIC T6				C			
TH02-Ex	INMETRO	Zone 1: BR-Ex Ex [ia]ib IIC T6				I			
Construction / Display									
Module (h = 22.5 mm)						3			
Module (h = 22.5 mm) with sensor connecting line						1			
Module (h = 22.5 mm) with snap-on fixing						4			
Module (h = 27.5 mm) for mounting on measuring module						Z			
Module with sensor connecting line, built into									
BUZH connection head						R			
BUSH connection head						P			
BUKH-Ex connection head						N			
Raised B connection head cover						L			
B connection head (complete head with raised cover)						K			
AUZH connection head						V			
AUSH connection head						U			
AGLH connection head without display						1) X			
AGLHD connection head with digital display (ProMeter)						1) D			
AGLHD connection head with digital display/HART configurator (CoMeter)						1) C			
Attention: The sensor connecting lines correspond to the order for the type of sensor or its type of circuitry									
Module, built into									
Aluminum field housing 80 x 75 x 57 mm, IP 65; 2 x M16 x 1.5						A			
Polyester field housing 75 x 80 x 55 mm, IP 65; 2 x M16 x 1.5						9			
Aluminum field housing 80x175x57 mm, IP 65; 1 x M16 x 1.5; 1 x M20 x 1.5 with separate terminal block						F			
Polyester field housing 75x190x55 mm, IP 65; 1 x M16 x 1.5; 1 x M20 x 1.5 with separate terminal block						E			
Note: Other field housings with several transmitters or especially for pipe mounting on request									
Programming									
Factory standard parameters Pt 100, 4 wire circuit, 0 ... 100 °C, damping off, direct action characteristic, overranging at sensor or device error (>= 22 mA)						0			
Customer specific parameter settings (e. g. TAG Number)						1			

Continued on next page

1) Standard: Aluminum, metal-cable-screw-connection M20 x 1.5 EEx e, protective pipe connection M24 x 1.5 (optional M20 x 1.5; 1/2" NPT; 3/4" NPT) (do not use for EEx d applications, see data sheet 10/10-3.28 EN for EEx d details)

Ordering information (continued)

Head mounted Temperature Transmitter TH02 / TH02-Ex	Variant digit No.	1- 7	11	12	13			
	Catalog No.	V11518-						
Calibration Certificate								
without			0					
2 point			1					
9 point			2					
Certificates								
without			0					
SIL2 - Declaration of conformity			2					
Accessories								
	Catalog No.							
ABB FSK modem [EEx ib] IIC (parameter setting in the installation)	see Data Sheet 10/63-6.71 EN							
Device Management Tool DSV4xx (SMART VISION)	see Data Sheet 10/63-1.20 EN							

Note:
**For a local programming on the desk the universal FSK programming set
can be used as Hardware
(see Data Sheet 10/63-6.71 EN: ordering information)**

ABB has Sales & Customer Support
expertise in over 100 countries worldwide.

www.abb.com/instrumentation

The Company's policy is one of continuous product
improvement and the right is reserved to modify the
information contained herein without notice.

Printed in the Fed. Rep. of Germany (10.2006)

© ABB 2006



ABB Ltd.
Salterbeck Trading Estate
Workington, Cumbria, CA14 5DS
UK
Tel: +44(0)1946-830-611
Fax: +44(0)1946-832-661

ABB Inc.
125 E. County Line Road
Warminster, PA 18974
USA
Tel: +1 215-674-6000
Fax: +1 215-674-7183

ABB Automation Products GmbH
Borsigstr. 2
63755 Alzenau
Germany
Tel: +49 551 905-534
Fax: +49 551 905-555
CCC-support.deapr@de.abb.com