You have purchased a high quality, modern instrument
from ABB Automation Products GmbH. We thank you for your purchase
and the confidence you have shown in us.

This Instruction Bulletin contains the instructions relating to the assembly and
installation of the instrument and the specifications for this instrument design.
ABB Automation Products GmbH reserves the right to make hardware and software refinements
without prior notice. Any questions which may arise that are not specifically answered by
these instructions should be referred to ABB Automation Products GmbH at our main plant in
Göttingen, Germany Tel. 049-551-905-0 or to one of our Technical Sales Bureaus for
further detailed information and specifications..

The interference resistance of the flowmeter system complies with the
NAMUR-Recommendations NE 21 5/93 and
EMC Guidelines 89/336/EWG
(EN 50081-1, EN 50082-2)

Introductory Safety Notes for the EMF System

Regulated Usage

The Electromagnetic Flowmeter [EMF] system is designed to the latest state of the art technology and is safe to operate. The EMF is to be installed only in the specified applications.

Every usage which exceeds the specified applications is considered to be non-specified. Any damages resulting therefrom are not the responsibility of the manufacturer.

The user assumes all risk for such operation.

The application specifications include the installation, start up, and service requirements specified by the manufacturer.

Installation, Start Up, and Service Personnel

Please read this Instruction Bulletin and the safety notes before attempting installation, start up, or service.

Only qualified personnel should have access to the instrument. The personnel should be familiar with the warnings and operating requirements contained in this Instruction Bulletin.

Observe that the connections are in accordance with the interconnection diagrams. Ground the flowmeter system.

Observe the warning notes designated in this document by the symbol:



Hazardous Material Information

In view of the Disposal Law of 27.08.86 (AbfG. 11 Special Wastes) the owner of special wastes is responsible for its care and the employer also has, according to the Hazardous Material Law of 01.10.86 (GefStoffV, 17 General Protection Responsibility), a responsibility to protect his employees, we must make note that:

- a) All flowmeter primaries and/or converters which are returned to ABB Automation Products for repair are to be free of any hazardous materials (acids, bases, solutions, etc.)
 - b) The flowmeter primaries must be flushed so that the hazardous materials are neutralized. There are cavities in the primaries between the metering spool and the housing. Therefore after metering hazardous materials the cavities are to be neutralized (see Hazardous Material Law -GefStoffV). For two piece housings the screws used to hold the sections together should be loosened. For primaries \geq DN 350 [14"] the drain plug at the lowest point in the housing is to be opened to remove the hazardous materials and to neutralize the coil and electrode cavities.
 - c) For service and repair **written confirmation** is required that the measures listed in a) and b) have been carried out.
 - d) Any costs incurred to remove the hazardous materials during repair will be billed to the owner of the equipment.
-

EG-Konformitätserklärung
EC-Certificate of Compliance



Hiermit bestätigen wir die Übereinstimmung der aufgeführten Geräte mit den Richtlinien des Rates der Europäischen Gemeinschaft. Die Sicherheits- und Installationshinweise der Produktdokumentation sind zu beachten.

Herewith we confirm that the listed instruments are in compliance with the council directives of the European Community. The safety and installation requirements of the product documentation must be observed.

Modell: DF2300

Model:

Richtlinie: EMV Richtlinie 89/336/EWG *

Directive: EMC directive 89/336/EEC *

Europäische Norm: EN 50081-1, 3/93 * EN 50081-2, 3/94 *
European Standard: EN 50082-1, 3/93 * EN 50082-2, 2/96 *

* einschließlich Nachträge
including alterations

Göttingen, 23. April 1997

Unterschrift / Signature

BZ-13-5025, Rev.0, E19359

✉ 37070 Göttingen
Deutschland/Germany

Tei. 0551/905-0
Fax 0551/905777

Commerzbank Göttingen (BLZ 26040030) 6124002
Deutsche Bank Göttingen (BLZ 26070072) 0182600
Dresdner Bank Göttingen (BLZ 26080024) 9232606
Sparkasse Göttingen (BLZ 26050001) 689507
Volksbank Göttingen (BLZ 26090050) 160004400

Handelsregister / Court of Register: Göttingen
HRB Nr. 423

Geschäftsführer / General Manager:
Wilfried Kiene

📦 Dransfelder Straße 2
37079 Göttingen

| Inhalt | Seite |
|--|--------------|
| 1. Serial Communication | 1 |
| 1.1 General Data Link Description | 1 |
| 2. ASCII Communication Protocol | 1 |
| 2.1 Monitor Mode (ASCII) | 1 |
| 2.2 Programming Mode (ASCII) | 2 |
| 2.3 Error Messages (ASCII) | 2 |
| 2.3.1 Protocol and Communication Errors | 2 |
| 3. ASCII2w Communication Protocol | 2 |
| 3.1 Monitor Mode (ASCII2w) | 3 |
| 3.2 Programming Mode (ASCII2w) | 3 |
| 3.3 Error Messages (ASCII2w) | 3 |
| 3.3.1 Protocol and Communication Errors | 3 |
| 4. Remote Display | 4 |
| 4.1 F&P Handheld Terminal 55 HT 4000 | 4 |
| 4.2 ANSI Terminal | 4 |
| 5. Data Link RS 485 | 4 |
| 5.1 Specifications RS 485 | 4 |
| 5.2 Installation RS 485 | 5 |
| 5.2.1 Operation Using a Handheld Terminal 55HT 4000 (max. 4 Instruments in Parallel) | 5 |
| 5.3 Operation from a PCS, SPC or PC (max. 32 Instruments in Parallel) | 5 |
| 6. General Commands - Function Characters | 6 |
| 6.1 A1 - Batch Quantity 1 | 6 |
| 6.2 A2 - Batch Quantity 2 | 7 |
| 6.3 A3 - Batch Quantity 3 | 8 |
| 6.4 AD - Instrument Address | 9 |
| 6.5 BA - Baudrate | 9 |
| 6.6 BM - Operating Mode | 10 |
| 6.7 BN - Batch Number | 12 |
| 6.8 DF - Flowrate in Engineering Units | 13 |
| 6.9 DI - Density | 13 |
| 6.10 DP - Damping | 14 |
| 6.11 DR - Empty Pipe Detector ON/OFF | 15 |
| 6.12 DS - Threshold Empty Pipe Detector | 16 |
| 6.13 EI - Units Qmax | 17 |
| 6.14 EZ - Units Totalizer | 19 |
| 6.15 E1 - Error Register 1 | 20 |
| 6.16 E2 - Error Register 2 | 21 |
| 6.17 EM - Error Log Register Reset | 21 |
| 6.18 FI - Stop Batch Cycle | 22 |
| 6.19 FR - Flow Direction | 22 |
| 6.20 IA - Alarm Current | 23 |
| 6.21 IB - Pulse Width | 24 |
| 6.22 IO - Current Output Range | 25 |
| 6.23 I> - Pulse Factor | 26 |
| 6.24 K1 - Calibration 1 | 27 |
| 6.25 K2 - Calibration 2 | 28 |
| 6.26 K3 - Calibration 3 | 29 |
| 6.27 LZ - Reset Totalizer | 29 |

Inhalt**Seite**

| | | |
|------|---|----|
| 6.28 | LV - Reset Difference Totalizer | 30 |
| 6.29 | LR - Reset Total Flow Totalizer | 30 |
| 6.30 | L1 - Error Log Register 1 | 31 |
| 6.31 | L2 - Error Log Register 2 | 32 |
| 6.32 | M - Instantaneous Flowrate | 33 |
| 6.33 | MD - Instantaneous Flowrate | 33 |
| 6.34 | MF - Averaging Factor | 34 |
| 6.35 | MK - Calculate Secondary Flow Correction Mode | 35 |
| 6.36 | MN - Measure Second Stage Flow Mode | 36 |
| 6.37 | M1 - Mode Register 1 | 37 |
| 6.38 | M2 - Mode Register 2 | 38 |
| 6.39 | NG - System Zero | 39 |
| 6.40 | NK - Second Stage Flow Correction Quantity | 40 |
| 6.41 | NM - Second Stage Flow Quantity | 40 |
| 6.42 | NW - Meter Size | 41 |
| 6.43 | NZ - Second Stage Time | 42 |
| 6.44 | O< - Forward Overflow Counter | 43 |
| 6.45 | O< - Reverse Overflow Counter | 43 |
| 6.46 | PR - Program Version | 44 |
| 6.47 | Qn - Flowmeter Primary Constant QmaxDN | 44 |
| 6.48 | Q> - Flow Range Qmax | 45 |
| 6.49 | RU - Start Batch | 46 |
| 6.50 | SM - Low Flow Cutoff | 46 |
| 6.51 | SP - Language | 47 |
| 6.52 | ST - Status Register | 48 |
| 6.53 | S2 - Status Register 2 | 49 |
| 6.54 | T1 - TAG Number (1) | 50 |
| 6.55 | T2 - TAG Number (2) | 51 |
| 6.56 | t1 - Maximum Batch Time 1 | 52 |
| 6.57 | t2 - Maximum Batch Time 2 | 53 |
| 6.58 | t3 - Maximum Batch Time 3 | 54 |
| 6.59 | VZ - Valve Closing Time | 54 |
| 6.60 | Z1 - Display Line 1 | 55 |
| 6.61 | Z2 - Display Line 2 | 56 |
| 6.62 | Z3 - Display Line 1 Multiplex | 57 |
| 6.63 | Z4 - Display Line 2 Multiplex | 57 |
| 6.64 | Z> - Difference Totalizer | 58 |
| 6.65 | Z< - Total Flow Totalizer | 58 |

1. Serial Communication

There are essentially two protocols available for serial communications: ASCII and ASCII2w. The ASCII2w-Protocol was developed for 2-Wire communications (RS485) and differs from the ASCII-Protocol in the following items:

1. **The converter always initiates its response with an ACK (06H).**
2. **The command mode code (M for Monitor Mode or P for Programming Mode) together with the Instrument Address are always returned by the converter.**
3. **The Instrument Address is also returned when an error message is transmitted.**
4. **Differing from the ASCII-Protocol (where only 1 : 1 communication is possible with a COPA-XF), it is possible to operate up to 32 COPA-XF instruments in parallel when using the ASCII2w-Protocol.**

! NOTE

The ProfibusDP- Protocol uses the ASCII-Protocol exclusively.

1.1 General Data Link Description

The COPA-XF can be operated using a serial data link over which its internal parameters can be interrogated and programmed during on-line operation. It is possible to connect the converter to a Process Control System (PCS), PC or user Programmable Controller (SPC).

The communication rate can be set in the range from 1200 to 9600 baud. The following baudrates are available:

1200, 2400, 4800 and 9600 Baud.

The following communication format has been selected:

--- START, D0, D1, D2, D3, D4, D5, D6, PARITY, STOP ---

START 1 Startbit
 D0-D6 7 Databits
 PARITY 1 Paritybit
 STOP 1 Stopbit

The converter hardware includes a RS485 data link.

The software provides the user with two data link protocol selections:

ASCII and ASCII2w

Both ASCII-Protocols are described in the following sections.

2. ASCII Communication Protocol

The communication is always initiated by the host computer. The converter reacts only to a specific command from the host computer.

The ASCII-Protocol recognizes two operating modes. Converter parameters can be interrogated (Monitor Mode) or programmed (Programming Mode).

The communication is always initiated with the character SOH (Start of Header = 01H) followed by "M" for Monitor Mode or "P" for Programming Mode and "two function characters" for the required action followed a "maximum of eight data bytes". The communication is terminated with the "CR" (Carriage Return) and "LF" (Line Feed) characters.

The converter also initiates its response with SOH. Then the "two function characters" are transmitted followed by a "maximum of 8 data bytes". The data can include a sign ("-") for minus and a decimal point ("."). Leading or trailing zeros need not be transmitted.

All data received by the converter is checked by various means. In addition to checking the even parity of the communication the converter monitors that the protocol was followed exactly (function characters as well as the number and type of data). A plausibility check is also made before any data is accepted. If an error is detected the converter transmits an error message (function character „X" and a two character error number). If no error is detected, the converter accepts the new data and as confirmation, sends the same data back to the host computer in the same format.

The communication is completed.

2.1 Monitor Mode (ASCII)

All the parameter settings and status information can be interrogated from the converter in this mode. The corresponding protocol has the following format:

a) Request from Host Computer

| Host Computer → Converter | | | | | | | |
|---------------------------|---|----|----|----|----|----|--|
| SOH | M | A1 | A0 | K1 | K0 | CR | LF |
| . | . | . | . | . | . | . | . |
| . | . | . | . | . | . | . | . |
| . | . | . | . | . | . | . | Line Feed = 0AH |
| . | . | . | . | . | . | . | Carriage Return = 0DH |
| . | . | . | . | . | . | . | Two function characters in ASCII-Code |
| . | . | . | . | . | . | . | Two character Instrument Address in ASCII-Code |
| . | . | . | . | . | . | . | M for Monitor Mode operation |
| Start of Heading = 01H | | | | | | | |

b) Response from Converter

| Converter → Host Computer | | | | | |
|---------------------------|----|----|-------|----|---|
| SOH | K1 | K0 | D7-D0 | CR | LF |
| . | . | . | . | . | . |
| . | . | . | . | . | . |
| . | . | . | . | . | Line Feed = 0AH |
| . | . | . | . | . | Carriage Return = 0DH |
| . | . | . | . | . | Maximum of eight data bytes in ASCII-Code |
| . | . | . | . | . | Two function characters in ASCII-Code |
| Start of Heading = 01H | | | | | |

A maximum of eight data bytes (the number is a function of the requested parameter) including a decimal point (".") and minus sign ("-") can be transmitted by the converter.

The Instrument Address must always contain two characters.

ASCII-Communication COPA-XF

2.2 Programming Mode (ASCII)

In the Programming Mode it is possible to enter or change parameters or functions. Function characters are utilized. The host computer addresses the converter as follows:

a.) Request from Host Computer

| Host Computer > Converter | | | | | | | | | |
|---------------------------|---|----|----|----|----|-----|----|----|--|
| SOH | P | A1 | A0 | K1 | K0 | D7- | DO | CR | LF |
| . | . | . | . | . | . | . | . | . | . |
| . | . | . | . | . | . | . | . | . | . |
| . | . | . | . | . | . | . | . | . | Line Feed |
| . | . | . | . | . | . | . | . | . | Carriage Return |
| . | . | . | . | . | . | . | . | . | Maximum of 8 data bytes in ASCII-Code |
| . | . | . | . | . | . | . | . | . | Two function characters in ASCII-Code |
| . | . | . | . | . | . | . | . | . | Two character Instrument Address in ASCII-Code |
| . | P | . | . | . | . | . | . | . | P for Programming Mode |
| . | . | . | . | . | . | . | . | . | Start of Heading = 0H1 |

b.) Response from Converter

| Converter > Host Computer | | | | | | |
|---------------------------|----|----|-----|----|----|---------------------------------------|
| SOH | K1 | K0 | D7- | DO | CR | LF |
| . | . | . | . | . | . | . |
| . | . | . | . | . | . | . |
| . | . | . | . | . | . | Line Feed = 0AH |
| . | . | . | . | . | . | Carriage Return = 0DH |
| . | . | . | . | . | . | Maximum of 8 data bytes in ASCII-Code |
| . | . | . | . | . | . | Two function characters in ASCII-Code |
| . | . | . | . | . | . | Start of Heading = 0H1 |

A maximum of eight data bytes (must always be the same number as those received) including a decimal point (".") and a minus sign ("-") can be transmitted by the converter. The Instrument Address must always contain two characters.

2.3 Error Messages (ASCII)

The data received by the converter is checked for adherence to the communication protocol as well as for plausibility. If an error is detected, for example, if the data value exceeds the prescribed range, an error message is transmitted by the converter:

Error Message from Converter:

| Converter > Host Computer | | | | | |
|---------------------------|---|----|----|----|--|
| SOH | X | F1 | F0 | CR | LF |
| . | . | . | . | . | . |
| . | . | . | . | . | . |
| . | . | . | . | . | Line Feed = 0AH |
| . | . | . | . | . | Carriage Return = 0DH |
| . | . | . | . | . | Two character Error Number in ASCII-Code |
| . | X | . | . | . | X for Error Message |
| . | . | . | . | . | Start of Heading = 01H |

2.3.1 Protocol and Communication Errors

| Error No. | Cause |
|-----------|--|
| 01 | Incorrect mode code (only M for Monitor Mode and P for Programming Mode) |
| 02 | Incorrect function characters |
| 04 | Number of data bytes exceeded |
| 05 | Parity error |

3. ASCII2w Communication Protocol

The communication is always initiated by the host computer. The converter reacts only to a specific commands from the host computer.

Converter data can be interrogated (Monitor Mode) or programmed (Programming Mode).

The communication always begins with the character SOH (Start of Header = 01H) followed by "M" for Monitor Mode or "P" for Programming Mode as well as a "two character Instrument Address" followed by "two function characters" for the required action and a "maximum of eight data bytes". The communication is terminated with the "CR" (Carriage Return) and "LF" (Line Feed) characters.

The converter initiates its response with "ACK" followed by "M" for Monitor Mode or "P" for Programming Mode together with a "two character Instrument Address".

The data can include a sign ("-") for minus and a decimal point ("."). Leading or trailing zeros need not be transmitted.

All data received by the converter is checked by various means. In addition to checking the even parity of the communication the converter monitors that the protocol was followed exactly (function characters as well as the number and type of data). A plausibility check is also made before any data is accepted. If an error is detected the converter transmits an error message (function character „X" and a "two character error number"). If no error is detected, the converter accepts the new data and as confirmation, sends the same data back to the host computer in the same format.

The communication is completed.

3.1 Monitor Mode (ASCII2w)

All the parameter settings and status information can be interrogated from the converter in this operating mode. The corresponding protocol has the following format:

a) Request from Host Computer

| Host Computer > Converter | | | | | | | | | |
|---------------------------|---|----|----|----|----|----|----|---|--|
| SOH | M | A1 | A0 | K1 | K0 | CR | LF | | |
| . | . | . | . | . | . | . | . | | |
| . | . | . | . | . | . | . | . | | |
| . | . | . | . | . | . | . | . | Line Feed = 0AH | |
| . | . | . | . | . | . | . | . | Carriage Return = 0DH | |
| . | . | . | . | . | . | . | . | Max. of 8 data bytes in ASCII-Code | |
| . | . | . | . | . | . | . | . | Two function characters in ASCII-Code | |
| . | . | . | . | . | . | . | . | Two character Instrument Address in ASCII-Code. | |
| . | . | . | . | . | . | . | . | M for operating mode Monitor Mode | |
| . | . | . | . | . | . | . | . | Start of Heading = 0H1 | |

b) Response from Converter

| Converter > Host Computer | | | | | | | | | |
|---------------------------|---|----|----|----|----|-------|----|----|---|
| ACK | M | A1 | A0 | K1 | K0 | D7-D0 | CR | LF | |
| . | . | . | . | . | . | . | . | . | . |
| . | . | . | . | . | . | . | . | . | . |
| . | . | . | . | . | . | . | . | . | Line Feed = 0AH |
| . | . | . | . | . | . | . | . | . | Carriage Return = 0DH |
| . | . | . | . | . | . | . | . | . | Max. of 8 data bytes in ASCII-Code |
| . | . | . | . | . | . | . | . | . | Two function characters in ASCII-Code |
| . | . | . | . | . | . | . | . | . | Two character Instrument Address in ASCII-Code. |
| . | . | . | . | . | . | . | . | . | M for operating mode Monitor Mode |
| . | . | . | . | . | . | . | . | . | ACKnowledge (06H) |

A maximum of eight data bytes (the number is a function of the requested parameter) including a decimal point (".") and minus sign ("-") can be transmitted by the converter. The Instrument Address must always contain two characters.

3.2 Programming Mode (ASCII2w)

In the Programming Mode it is possible to enter or change parameters or functions. Function characters are utilized. The host computer addresses the converter as follows:

a) Request from Host Computer

| Host Computer > Converter | | | | | | | | | |
|---------------------------|---|----|----|----|----|-----|----|----|---|
| SOH | P | A1 | A0 | K1 | K0 | D7- | D0 | CR | LF |
| . | . | . | . | . | . | . | . | . | . |
| . | . | . | . | . | . | . | . | . | . |
| . | . | . | . | . | . | . | . | . | Line Feed |
| . | . | . | . | . | . | . | . | . | Carriage Return |
| . | . | . | . | . | . | . | . | . | Max. of 8 data bytes in ASCII-Code |
| . | . | . | . | . | . | . | . | . | Two function characters in ASCII-Code |
| . | . | . | . | . | . | . | . | . | Two character Instrument Address in ASCII-Code. |
| . | . | . | . | . | . | . | . | . | P for Programming Mode |
| . | . | . | . | . | . | . | . | . | Start of Heading = 01H |

b) Response from Converter

| Converter > Host Computer | | | | | | | | | |
|---------------------------|---|----|----|----|----|-------|----|----|---|
| ACK | P | A1 | A0 | K1 | K0 | D7-D0 | CR | LF | |
| . | . | . | . | . | . | . | . | . | . |
| . | . | . | . | . | . | . | . | . | . |
| . | . | . | . | . | . | . | . | . | Line Feed = 0AH |
| . | . | . | . | . | . | . | . | . | Carriage Return = 0DH |
| . | . | . | . | . | . | . | . | . | Max. of 8 data bytes in ASCII-Code |
| . | . | . | . | . | . | . | . | . | Two function characters in ASCII-Code |
| . | . | . | . | . | . | . | . | . | Two character Instrument Address in ASCII-Code. |
| . | . | . | . | . | . | . | . | . | P for operating mode Programming Mode |
| . | . | . | . | . | . | . | . | . | ACKnowledge (06H) |

A maximum of eight data bytes (must always be the same number as those received) including a decimal point (".") and a minus sign ("-") can be transmitted by the converter. The Instrument Address must always contain two characters.

3.3 Error Messages (ASCII2w)

The data received by the converter is checked for adherence to the communication protocol as well as for plausibility. If an error is detected, for example, if the data values exceed the prescribed range, an error message is transmitted by the converter:

Error Message from Converter:

| Converter > Host Computer | | | | | | | | | |
|---------------------------|---|----|----|----|----|----|----|---|--|
| ACK | X | A1 | A0 | F1 | F0 | CR | LF | | |
| . | . | . | . | . | . | . | . | | |
| . | . | . | . | . | . | . | . | | |
| . | . | . | . | . | . | . | . | Line Feed = 0AH | |
| . | . | . | . | . | . | . | . | Carriage Return = 0DH | |
| . | . | . | . | . | . | . | . | Two character Error Number in ASCII-Code | |
| . | . | . | . | . | . | . | . | Two character Instrument Address in ASCII-Code. | |
| . | . | . | . | . | . | . | . | "X" for Error Message | |
| . | . | . | . | . | . | . | . | ACKnowledge (06H) | |

3.3.1 Protocol and Communication Errors

| Error No. | Cause |
|-----------|--|
| 01 | Incorrect mode code (only M for Monitor Mode and P for Programming Mode) |
| 02 | Incorrect function character |
| 04 | Number of data bytes exceeded |
| 05 | Parity error |

ASCII-Communication COPA-XF

4. Remote Display

A remote display can be realized by connecting a terminal to the serial data link. All the values stored in the COPA-XF converter can also be transmitted to a remote indicating device in the Programming Mode. It is also possible to configure the COPA-XF from that location.

A communication speed of 1200 or 2400 Baud is recommended.

Two terminal types are available as remote indicators:

- a) F&P Handheld Terminal
- b) ANSI Terminal

4.1 F&P Handheld Terminal 55 HT 4000

The foil keypad of the Handheld Terminal terminal is utilized for operation. In addition, the connection is constantly monitored by both the converter and the Handheld Terminal. If the connection is interrupted, it is automatically reestablished. Detailed information may be found in the Instruction Bulletin "F&P Handheld Terminal". See also Sect. 5.2.1., Page 5

4.2 ANSI Terminal

If an ANSI Terminal is utilized, the communication must be established using the following command:

| | | | | | | | | |
|-----|------------------------|----|----|---|---|------|----|-----------------------|
| SOH | P | A1 | A0 | ESC | X | ANSI | CR | LF |
| . | . | . | . | . | . | . | . | . |
| . | . | . | . | . | . | . | . | . |
| . | . | . | . | . | . | . | . | Line Feed = 0AH |
| . | . | . | . | . | . | . | . | Carriage Return = 0DH |
| . | . | . | . | . | . | ANSI | . | . |
| . | . | . | . | . | X | . | . | . |
| . | . | . | . | ESC = 1 BH | . | . | . | . |
| . | . | . | . | Two character Instrument Address in ASCII-Code. | . | . | . | . |
| . | P for Programming Mode | . | . | . | . | . | . | . |
| . | Start of Heading = 0H1 | . | . | . | . | . | . | . |

The connection is terminated with

ESC O S (PF4).

ESC-Sequences and Control Characters are both used in the transmissions from the COPA-XF:

| ESC-Sequence/ Control Character | Function |
|------------------------------------|--------------------------------|
| ESC [2 J ESC [H | Clear screen and cursor home |
| ESC [H | Cursor home |
| ESC [2; 1 H | Cursor to start of second line |
| ESC [C | Cursor right |
| ESC [D | Cursor left |
| BEL | Bell character |

The following keys on the terminal are available to the user:

| Key | ASCII-Character | Hex-Code |
|--------|-----------------|----------|
| 0 | 0 | 30 |
| 1 | 1 | 31 |
| 2 | 2 | 32 |
| 3 | 3 | 33 |
| 4 | 4 | 34 |
| 5 | 5 | 35 |
| 6 | 6 | 36 |
| 7 | 7 | 37 |
| 8 | 8 | 38 |
| 9 | 9 | 39 |
| . | . | 2E |
| RETURN | CR | 0D |
| DEL | DEL | 7F |
| - | - | 2D |
| ↑ | ESC [A | 1B 5B 41 |
| ↓ | ESC [B | 1B 5B 42 |

5. Data Link RS 485

5.1 Specifications RS 485

| | |
|------------------------|-----------|
| Transmission mode: | Symmetric |
| Max. no of drivers: | 32 |
| Max. no. of receivers: | 32 |
| Max. cable length: | 1200 m |
| Max. data rate: | 10 MBaud |
| Signal w/o load: | 5 V |
| Signal w/ load: | 1.5 V |

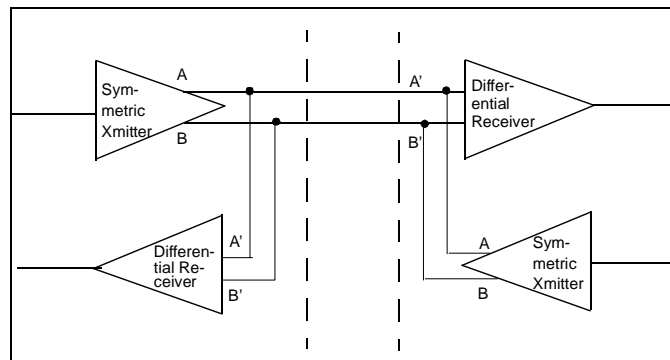

Cable Length as a Function of Baudrate:

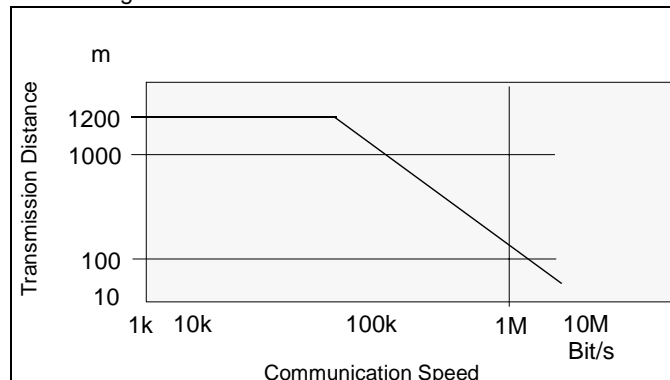

5.2 Installation RS 485

5.2.1 Operation Using a Handheld Terminal 55HT 4000 (max. 4 Instruments in Parallel)

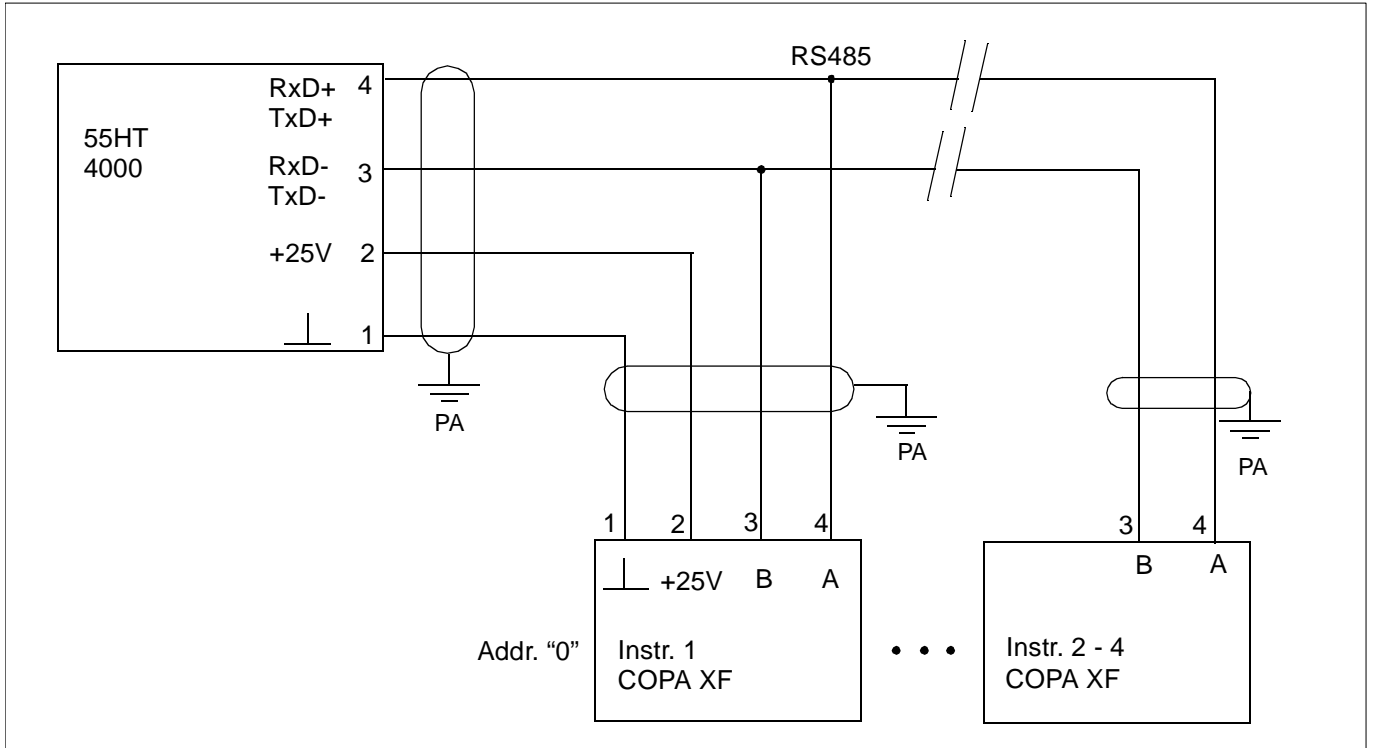

Fig. 1

! Note

One of the COPA-XF instruments or an external supply can be utilized for the 24 VDC supply required by the Handheld Terminal 55HT4000.

5.2.2 Operation from a PCS, SPC or PC (max. 32 Instruments in Parallel)

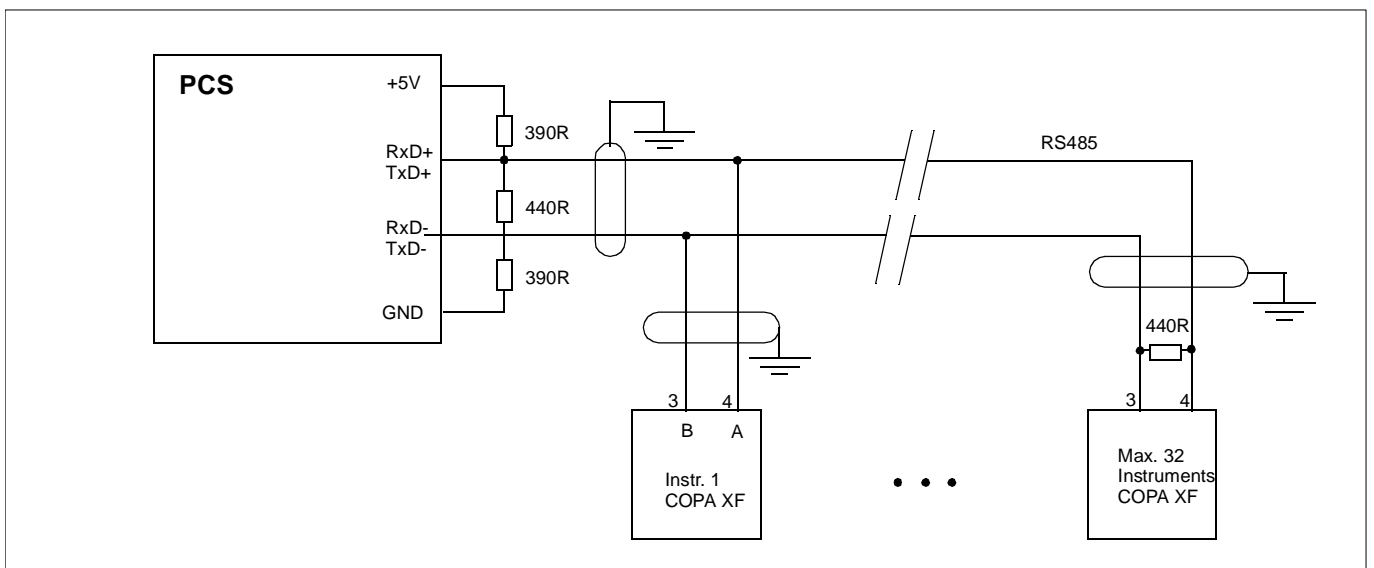

Fig. 2

ASCII-Communication COPA-XF

6. General Commands - Function Characters

6.1 A1 - Batch Quantity 1

Function Characters: **A1**

Parameter/Function: Batch quantity 1

Units: Units see "Units Totalizer" (EZ)

Comments: Parameter only available for Operating Mode "Batch 5kHz".
See also „Batch Quantity 1, 2 and 3“

Monitor Mode

| Data | | Comments |
|--------|--------|----------|
| Format | Number | |
| F | 6 | - |

Programming Mode

| Data | | Data Range | Error Message | | Comments |
|--------|--------|---------------------------------|---------------|-----------------------------|----------|
| Format | Number | | No. | Cause | |
| F | 6 | $0 \geq \text{Entry} \geq 9999$ | 99 | Entry outside of data range | - |

6.2 A2 - Batch Quantity 2

Function Characters: **A2**

Parameter/Function: Batch quantity 2

Units: Units see "Units Totalizer" (EZ)

Comments: Parameter only available for Operating Mode "Batch".
See also „Batch Quantity 1, 2 and 3”

Monitor Mode

| Data | | Comments |
|--------|--------|----------|
| Format | Number | |
| F | 6 | - |

Programming Mode

| Data | | Data Range | Error Message | | Comments |
|--------|--------|---------------------------------|---------------|-----------------------------|----------|
| Format | Number | | No. | Cause | |
| F | 6 | $0 \geq \text{Entry} \geq 9999$ | 99 | Entry outside of data range | - |

ASCII-Communication COPA-XF

6.3 A3 - Batch Quantity 3

Function Characters: **A3**

Parameter/Function: Batch quantity 3

Units: Units see "Units Totalizer" (EZ)

Comments: Parameter only available in Operating Mode "Batch" .
See also „Batch Quantity 1, 2 and 3”

Monitor Mode

| Data | | Comments |
|--------|--------|----------|
| Format | Number | |
| F | 6 | - |

Programming Mode

| Data | | Data Range | Error Message | | Comments |
|--------|--------|------------------|---------------|-----------------------------|----------|
| Format | Number | | No. | Cause | |
| F | 6 | 0 ≥ Entry ≥ 9999 | 99 | Entry outside of data range | - |

6.4 AD - Instrument Address

Function Characters: **AD**

Parameter/Function: Instrument address

Units: -

Comments: The Instrument Address can be changed. The new Instrument Address must be used the next time that communication is established with this converter.

Programming Mode

| Data | | Data Range | Error Message | | Comments |
|--------|--------|-------------------------------|---------------|-----------------------------|--|
| Format | Number | | No. | Cause | |
| I | 3 | $0 \leq \text{Entry} \leq 99$ | 22 | Entry outside of data range | The same Instrument Address may no be assigned to two instruments. |

6.5 BA - Baudrate

Function Characters: **BA**

Parameter/Function: Baudrate

Units: -

Comments: The baudrate is changed immediately, i.e. the converter acknowledges the change using the new baudrate.

WARNING!

This command is only available for Software Versions from D699B181U01 B.21 or D699B183U01 X.21.

Programming Mode

| Data | | Data Range | Error Message | | Comments | |
|--------|--------|------------------------------|---------------|-----------------------------|----------|-----------|
| Format | Number | | No. | Cause | Data | Baudrate |
| I | 3 | $0 \leq \text{Entry} \leq 3$ | 99 | Entry outside of data range | | |
| | | | | | 0 | 1200 Baud |
| | | | | | 1 | 2400 Baud |
| | | | | | 2 | 4800 Baud |
| | | | | | 3 | 9600 Baud |

ASCII-Communication COPA-XF

6.6 BM - Operating Mode

Function Characters: **BM**

Parameter/Function: Operating mode

Units: -

Comments: Converter operating mode.

Monitor Mode

| Data | | Comments | |
|--------|--------|-------------|----------------------------------|
| Format | Number | | |
| 1 | 3 | Data | Explanation |
| | | 000 | Standard continuous measurements |
| | | 001 | Standard Batch |
| | | 002 | Batch 1kHz |
| | | 003 | Batch 5kHz |
| | | 004 | Batch 2kHz |
| | | 005 | Batch 5kHz |
| | | 006 | Conti 1kHz |
| | | 007 | Conti 5kHz |
| | | 008 | Conti 2kHz |

ASCII-Communication COPA-XF

Programming Mode

| Data | | Data Range | No. | Error Message | | Comments | | | | | | | | | | | | | | | | | | | | | | | | | | | | | | | | | | | | | | | | | | | | | | | | | | | | | | | | | | | | | | | | | | | | | | | | | | | | | | | | | | | | | | | | | | | | | | | | | | | | | | | | | | | | | | | | | | | | | | | | | | | | | | | | | | | | | | | | | | | | | | | | | | | | | | | | | | | | | | | | | | | | | | | | | | | | | | |
|---------|----------------|------------------------------|-----|-----------------------------|---|--|---------|----------------|---|---|---|--|--|--|--|--|--|---|---|---|---|---|---|---|---|---|---|---|---|---|---|---|---|---|---|---|---|---|---|---|---|---|---|---|---|---|---|---|---|---|---|---|---|---|---|---|---|---|---|---|---|---|---|---|---|---|---|---|---|---|---|---|---|---|---|---|--|---|---|---|---|---|---|---|---|---|---|---|---|---|---|---|---|---|---|---|---|---|---|---|---|---|---|---|---|--|--|--|--|--|---|---|---|---|---|---|---|---|---|---|---|---|---|---|---|----|---|--|--|--|--|---|---|---|---|---|----|---|--|--|--|--|---|---|---|---|---|----|--|--|--|---|--|--|--|--|--|--|----|--|--|--|--|---|--|--|--|--|--|----|--|--|---|--|--|--|--|--|--|--|
| Format | Number | | | Cause | | | | | | | | | | | | | | | | | | | | | | | | | | | | | | | | | | | | | | | | | | | | | | | | | | | | | | | | | | | | | | | | | | | | | | | | | | | | | | | | | | | | | | | | | | | | | | | | | | | | | | | | | | | | | | | | | | | | | | | | | | | | | | | | | | | | | | | | | | | | | | | | | | | | | | | | | | | | | | | | | | | | | | | | | | | | | | | | |
| I | 3 | $0 \leq \text{Entry} \leq 8$ | 99 | Entry outside of data range | | The allowable Operating Modes are a function of the Instrument Version: <table border="1" style="width: 100%; text-align: center;"> <thead> <tr> <th rowspan="2">Version</th> <th colspan="10">Operating Mode</th> </tr> <tr> <th>0</th><th>1</th><th>2</th><th>3</th><th>4</th><th>5</th><th>6</th><th>7</th><th>8</th> </tr> </thead> <tbody> <tr><td>1</td><td>x</td><td>x</td><td>x</td><td>x</td><td>x</td><td>x</td><td>x</td><td>x</td><td>x</td><td>x</td></tr> <tr><td>2</td><td>x</td><td>x</td><td>x</td><td>x</td><td>x</td><td>x</td><td>x</td><td>x</td><td>x</td><td>x</td></tr> <tr><td>3</td><td>x</td><td>x</td><td>x</td><td>x</td><td>x</td><td>x</td><td>x</td><td>x</td><td>x</td><td>x</td></tr> <tr><td>4</td><td>x</td><td>x</td><td>x</td><td>x</td><td>x</td><td>x</td><td>x</td><td>x</td><td>x</td><td>x</td></tr> <tr><td>5</td><td>x</td><td>x</td><td>x</td><td>x</td><td>x</td><td></td><td>x</td><td>x</td><td>x</td><td>x</td></tr> <tr><td>6</td><td>x</td><td>x</td><td>x</td><td>x</td><td>x</td><td>x</td><td>x</td><td>x</td><td>x</td><td>x</td></tr> <tr><td>7</td><td>x</td><td>x</td><td>x</td><td>x</td><td>x</td><td>x</td><td>x</td><td>x</td><td>x</td><td>x</td></tr> <tr><td>8</td><td>x</td><td></td><td></td><td></td><td></td><td></td><td>x</td><td>x</td><td>x</td><td>x</td></tr> <tr><td>9</td><td>x</td><td>x</td><td>x</td><td>x</td><td>x</td><td>x</td><td>x</td><td>x</td><td>x</td><td>x</td></tr> <tr><td>10</td><td>x</td><td></td><td></td><td></td><td></td><td>x</td><td>x</td><td>x</td><td>x</td><td>x</td></tr> <tr><td>20</td><td>x</td><td></td><td></td><td></td><td></td><td>x</td><td>x</td><td>x</td><td>x</td><td>x</td></tr> <tr><td>21</td><td></td><td></td><td></td><td>x</td><td></td><td></td><td></td><td></td><td></td><td></td></tr> <tr><td>22</td><td></td><td></td><td></td><td></td><td>x</td><td></td><td></td><td></td><td></td><td></td></tr> <tr><td>23</td><td></td><td></td><td>x</td><td></td><td></td><td></td><td></td><td></td><td></td><td></td></tr> </tbody> </table> | Version | Operating Mode | | | | | | | | | | 0 | 1 | 2 | 3 | 4 | 5 | 6 | 7 | 8 | 1 | x | x | x | x | x | x | x | x | x | x | 2 | x | x | x | x | x | x | x | x | x | x | 3 | x | x | x | x | x | x | x | x | x | x | 4 | x | x | x | x | x | x | x | x | x | x | 5 | x | x | x | x | x | | x | x | x | x | 6 | x | x | x | x | x | x | x | x | x | x | 7 | x | x | x | x | x | x | x | x | x | x | 8 | x | | | | | | x | x | x | x | 9 | x | x | x | x | x | x | x | x | x | x | 10 | x | | | | | x | x | x | x | x | 20 | x | | | | | x | x | x | x | x | 21 | | | | x | | | | | | | 22 | | | | | x | | | | | | 23 | | | x | | | | | | | |
| Version | Operating Mode | | | | | | | | | | | | | | | | | | | | | | | | | | | | | | | | | | | | | | | | | | | | | | | | | | | | | | | | | | | | | | | | | | | | | | | | | | | | | | | | | | | | | | | | | | | | | | | | | | | | | | | | | | | | | | | | | | | | | | | | | | | | | | | | | | | | | | | | | | | | | | | | | | | | | | | | | | | | | | | | | | | | | | | | | | | | | | | | | | | |
| | 0 | 1 | 2 | 3 | 4 | | 5 | 6 | 7 | 8 | | | | | | | | | | | | | | | | | | | | | | | | | | | | | | | | | | | | | | | | | | | | | | | | | | | | | | | | | | | | | | | | | | | | | | | | | | | | | | | | | | | | | | | | | | | | | | | | | | | | | | | | | | | | | | | | | | | | | | | | | | | | | | | | | | | | | | | | | | | | | | | | | | | | | | | | | | | | | | | | | | | | | | | | | | |
| 1 | x | x | x | x | x | | x | x | x | x | x | | | | | | | | | | | | | | | | | | | | | | | | | | | | | | | | | | | | | | | | | | | | | | | | | | | | | | | | | | | | | | | | | | | | | | | | | | | | | | | | | | | | | | | | | | | | | | | | | | | | | | | | | | | | | | | | | | | | | | | | | | | | | | | | | | | | | | | | | | | | | | | | | | | | | | | | | | | | | | | | | | | | | | | | | |
| 2 | x | x | x | x | x | | x | x | x | x | x | | | | | | | | | | | | | | | | | | | | | | | | | | | | | | | | | | | | | | | | | | | | | | | | | | | | | | | | | | | | | | | | | | | | | | | | | | | | | | | | | | | | | | | | | | | | | | | | | | | | | | | | | | | | | | | | | | | | | | | | | | | | | | | | | | | | | | | | | | | | | | | | | | | | | | | | | | | | | | | | | | | | | | | | | |
| 3 | x | x | x | x | x | | x | x | x | x | x | | | | | | | | | | | | | | | | | | | | | | | | | | | | | | | | | | | | | | | | | | | | | | | | | | | | | | | | | | | | | | | | | | | | | | | | | | | | | | | | | | | | | | | | | | | | | | | | | | | | | | | | | | | | | | | | | | | | | | | | | | | | | | | | | | | | | | | | | | | | | | | | | | | | | | | | | | | | | | | | | | | | | | | | | |
| 4 | x | x | x | x | x | | x | x | x | x | x | | | | | | | | | | | | | | | | | | | | | | | | | | | | | | | | | | | | | | | | | | | | | | | | | | | | | | | | | | | | | | | | | | | | | | | | | | | | | | | | | | | | | | | | | | | | | | | | | | | | | | | | | | | | | | | | | | | | | | | | | | | | | | | | | | | | | | | | | | | | | | | | | | | | | | | | | | | | | | | | | | | | | | | | | |
| 5 | x | x | x | x | x | | | x | x | x | x | | | | | | | | | | | | | | | | | | | | | | | | | | | | | | | | | | | | | | | | | | | | | | | | | | | | | | | | | | | | | | | | | | | | | | | | | | | | | | | | | | | | | | | | | | | | | | | | | | | | | | | | | | | | | | | | | | | | | | | | | | | | | | | | | | | | | | | | | | | | | | | | | | | | | | | | | | | | | | | | | | | | | | | | | |
| 6 | x | x | x | x | x | | x | x | x | x | x | | | | | | | | | | | | | | | | | | | | | | | | | | | | | | | | | | | | | | | | | | | | | | | | | | | | | | | | | | | | | | | | | | | | | | | | | | | | | | | | | | | | | | | | | | | | | | | | | | | | | | | | | | | | | | | | | | | | | | | | | | | | | | | | | | | | | | | | | | | | | | | | | | | | | | | | | | | | | | | | | | | | | | | | | |
| 7 | x | x | x | x | x | | x | x | x | x | x | | | | | | | | | | | | | | | | | | | | | | | | | | | | | | | | | | | | | | | | | | | | | | | | | | | | | | | | | | | | | | | | | | | | | | | | | | | | | | | | | | | | | | | | | | | | | | | | | | | | | | | | | | | | | | | | | | | | | | | | | | | | | | | | | | | | | | | | | | | | | | | | | | | | | | | | | | | | | | | | | | | | | | | | | |
| 8 | x | | | | | | | x | x | x | x | | | | | | | | | | | | | | | | | | | | | | | | | | | | | | | | | | | | | | | | | | | | | | | | | | | | | | | | | | | | | | | | | | | | | | | | | | | | | | | | | | | | | | | | | | | | | | | | | | | | | | | | | | | | | | | | | | | | | | | | | | | | | | | | | | | | | | | | | | | | | | | | | | | | | | | | | | | | | | | | | | | | | | | | | |
| 9 | x | x | x | x | x | | x | x | x | x | x | | | | | | | | | | | | | | | | | | | | | | | | | | | | | | | | | | | | | | | | | | | | | | | | | | | | | | | | | | | | | | | | | | | | | | | | | | | | | | | | | | | | | | | | | | | | | | | | | | | | | | | | | | | | | | | | | | | | | | | | | | | | | | | | | | | | | | | | | | | | | | | | | | | | | | | | | | | | | | | | | | | | | | | | | |
| 10 | x | | | | | | x | x | x | x | x | | | | | | | | | | | | | | | | | | | | | | | | | | | | | | | | | | | | | | | | | | | | | | | | | | | | | | | | | | | | | | | | | | | | | | | | | | | | | | | | | | | | | | | | | | | | | | | | | | | | | | | | | | | | | | | | | | | | | | | | | | | | | | | | | | | | | | | | | | | | | | | | | | | | | | | | | | | | | | | | | | | | | | | | | |
| 20 | x | | | | | | x | x | x | x | x | | | | | | | | | | | | | | | | | | | | | | | | | | | | | | | | | | | | | | | | | | | | | | | | | | | | | | | | | | | | | | | | | | | | | | | | | | | | | | | | | | | | | | | | | | | | | | | | | | | | | | | | | | | | | | | | | | | | | | | | | | | | | | | | | | | | | | | | | | | | | | | | | | | | | | | | | | | | | | | | | | | | | | | | | |
| 21 | | | | x | | | | | | | | | | | | | | | | | | | | | | | | | | | | | | | | | | | | | | | | | | | | | | | | | | | | | | | | | | | | | | | | | | | | | | | | | | | | | | | | | | | | | | | | | | | | | | | | | | | | | | | | | | | | | | | | | | | | | | | | | | | | | | | | | | | | | | | | | | | | | | | | | | | | | | | | | | | | | | | | | | | | | | | | | | | | | | | | |
| 22 | | | | | x | | | | | | | | | | | | | | | | | | | | | | | | | | | | | | | | | | | | | | | | | | | | | | | | | | | | | | | | | | | | | | | | | | | | | | | | | | | | | | | | | | | | | | | | | | | | | | | | | | | | | | | | | | | | | | | | | | | | | | | | | | | | | | | | | | | | | | | | | | | | | | | | | | | | | | | | | | | | | | | | | | | | | | | | | | | | | | | |
| 23 | | | x | | | | | | | | | | | | | | | | | | | | | | | | | | | | | | | | | | | | | | | | | | | | | | | | | | | | | | | | | | | | | | | | | | | | | | | | | | | | | | | | | | | | | | | | | | | | | | | | | | | | | | | | | | | | | | | | | | | | | | | | | | | | | | | | | | | | | | | | | | | | | | | | | | | | | | | | | | | | | | | | | | | | | | | | | | | | | | | | | |

ASCII-Communication COPA-XF

6.7 BN - Batch Number

Function Characters: **BN**

Parameter/Function: Batch number

Units: -

Comments: Parameter only available for Operating Mode "Batch".

Monitor Mode

| Data | | Comments | |
|--------|--------|----------|--|
| Format | Number | | |
| I | 3 | Data | Explanation |
| | | 000 | Batch 1 (Batch Quantity 1, Max. Fill Time 1 etc.) active |
| | | 001 | Batch 2 |
| | | 002 | Batch 3 |

Programming Mode

| Data | | Data Range | Error Message | | Comments |
|--------|--------|------------------------------|---------------|-----------------------------|-------------------|
| Format | Number | | No. | Cause | |
| I | 3 | $0 \leq \text{Entry} \leq 2$ | 99 | Entry outside of data range | See Monitor Mode. |

6.8 DF - Flowrate in Engineering Units

Function Characters: **DF**

Parameter/Function: Instantaneous flowrate value in direct reading engineering units

Units: Units see "Units Qmax" (EI).

Comments: -

Monitor Mode

| Data | | Comments |
|--------|--------|---|
| Format | Number | |
| F | 7 | A negative output indicates reverse flow. |

6.9 DI - Density

Function Characters: **DI**

Parameter/Function: Density

Units: g / cm³

Comments: Density value utilized for mass units (Units Qmax, Units Totalizer).

Monitor Mode

| Data | | Comments |
|--------|--------|----------|
| Format | Number | |
| F | 6 | - |

Programming Mode

| Data | | Data Range | Error Message | | Comments |
|--------|--------|------------------|---------------|---------------------|--|
| Format | Number | | No. | Cause | |
| F | 6 | 0.01 ≤ Entry ≤ 5 | 45 | Entry < 0.01 | Error 40 can only occur for the Operating Modes "Standard conti. " and "Standard Batch". The "Frequency" is based on the scaled output frequency at 100% flowrate. |
| | | | 44 | Entry > 5 | |
| | | | 40 | Frequency > 5kHz | |
| | | | 41 | Frequency too small | |

ASCII-Communication COPA-XF

6.10 DP - Damping

Function Characters: **DP**

Parameter/Function: Damping

Units: s

Comments: The damping value is the response time of the converter value to change from 0 to 99% of a step change.
The damping function is available only for the "Continuous Operating Modes" ("Standard conti.", "Conti 1kHz", "Conti 2kHz" or "Conti 5kHz").

Monitor Mode

| Data | | Comments |
|--------|--------|----------|
| Format | Number | |
| F | 6 | - |

Programming Mode

| Data | | Data Range | Error Message | | Comments |
|--------|--------|--------------------|---------------|---------------|---|
| Format | Number | | No. | Cause | |
| F | 6 | 0.125 < Entry < 20 | 20 | Entry > 20 | The lower entry limit (0.125s) increases to 0.25s for an excitation frequency of 12 ½ Hz. |
| | | | 21 | Entry < 0.125 | |

6.11 DR - Empty Pipe Detector ON/OFF

Function Characters: **DR**

Parameter/Function: Turn empty pipe detector on/off

Units: -

Comments: The Empty Pipe Detector is only available for Operating Mode "Standard konti."

Monitor Mode

| Data | | Comments | |
|--------|--------|-------------|---------------------|
| Format | Number | | |
| l | 3 | Data | Explanation |
| | | 0 | Detector turned off |
| | | 1 | Detector turned on |

Programming Mode

| Data | | Data Range | Error Message | | Comments |
|--------|--------|------------|---------------|-----------|-------------------|
| Format | Number | | No. | Cause | |
| 1 | 3 | 0 or 1 | 99 | Entry > 1 | See Monitor Mode. |

ASCII-Communication COPA-XF

6.12 DS - Threshold Empty Pipe Detector

Function Characters: **DS**

Parameter/Function: Threshold for the empty pipe detector

Units: Hz

Comments:

Monitor Mode

| Data | | Comments |
|--------|--------|----------|
| Format | Number | |
| F | 6 | - |

Programming Mode

| Data | | Data Range | Error Message | | Comments |
|--------|--------|---------------------------------|---------------|--------------|----------|
| Format | Number | | No. | Cause | |
| F | 6 | $0 \leq \text{Entry} \leq 3000$ | 56 | Entry > 3000 | |

6.13 EI - Units Qmax

Function Characters: **EI**

Parameter/Function: Units for Qmax

Units: -

Comments: The "Units Qmax" are utilized for the output of the "Instantaneous Flowrate in Engineering Units".

Monitor Mode

| Data | | Comments | |
|--------|--------|-------------|--------------------|
| Format | Number | | |
| I | 3 | Data | Explanation |
| | | 000 | l/s |
| | | 001 | l/min |
| | | 002 | l/h |
| | | 016 | hl/s |
| | | 017 | hl/min |
| | | 018 | hl/h |
| | | 032 | m3/s |
| | | 033 | m3/min |
| | | 034 | m3/h |
| | | 048 | igps |
| | | 049 | igpm |
| | | 050 | igph |
| | | 064 | mgd |
| | | 065 | gpm |
| | | 066 | gph |
| | | 080 | bbl/s |
| | | 081 | bbl/min |
| | | 082 | bbl/h |
| | | 096 | bls/day |
| | | 097 | bls/min |
| | | 098 | bls/h |
| | | 112 | kg/s |
| | | 113 | kg/min |
| | | 114 | kg/h |
| | | 128 | t/s |
| | | 129 | t/min |
| | | 130 | t/h |
| | | 144 | g/s |
| | | 145 | g/min |
| | | 146 | g/h |
| | | 160 | ml/s |

ASCII-Communication COPA-XF

Monitor Mode

| Data | | Comments |
|--------|--------|-------------------------------|
| Format | Number | |
| | 161 | ml/min |
| | 162 | ml/h |
| | 176 | MI/min |
| | 177 | MI/h |
| | 178 | MI/day |
| | 192 | lbs/s |
| | 193 | lbs/min |
| | 194 | lbs/h |
| | 208 | uton/min |
| | 209 | uton/h |
| | 210 | uton/day |
| | 224 | User programmable Units / s |
| | 225 | User programmable Units / min |
| | 226 | User programmable Units / h |

Programming Mode

| Data | | Data Range | Error Message | | Comments |
|--------|--------|------------------|---------------|-----------------|----------|
| Format | Number | | No. | Cause | |
| I | 3 | See Monitor Mode | 48 | Incorrect value | - |

6.14 EZ - Units Totalizer

Function Characters: **EZ**

Parameter/Function: Units for totalizer

Units: -

Comments:

Monitor Mode

| Data | | Comments | |
|--------|--------|-------------|-------------------------|
| Format | Number | | |
| I | 3 | Data | Explanation |
| | | 0 | l |
| | | 1 | hl |
| | | 2 | m3 |
| | | 3 | igal |
| | | 4 | gal |
| | | 5 | mgal |
| | | 6 | bbl |
| | | 7 | bls |
| | | 8 | kg |
| | | 9 | t |
| | | 10 | g |
| | | 11 | ml |
| | | 12 | MI |
| | | 13 | lbs |
| | | 14 | uton |
| | | 15 | User programmable Units |

Programming Mode

| Data | | Data Range | Error Message | | Comments |
|--------|--------|-------------------------------|---------------|---------------------|--|
| Format | Number | | No. | Cause | |
| 1 | 3 | $0 \leq \text{Entry} \leq 15$ | 99 | Entry > 3000 | Errors 40 and 41 occur only for the Operating Modes "Standard conti." and "Standard Batch". The "Frequency" is based on the scaled frequency output at 100% flowrate. |
| | | | 40 | Frequency > 5kHz | |
| | | | 41 | Frequency too small | |

ASCII-Communication COPA-XF

6.15 E1 - Error Register 1

Function Characters: **E1**

Parameter/Function: Error Register 1

Units: -

Comments: Output the contents of the Error Register 1

Monitor Mode

| Data | | Comments | | | | | | | | | | | | | | | | | | |
|--------|--|---|-----|-------|---|----------------------|---|-----------------------------------|---|---------------------------------------|---|---------------------------|---|----------------------------|---|--------------------------|---|-------------------------------|---|--|
| Format | Number | | | | | | | | | | | | | | | | | | | |
| I | 3 | The contents of the Error Register are outputted in coded form. The individual errors are identified by the Bit: <table border="1" data-bbox="284 913 1442 1227"><thead><tr><th>Bit</th><th>Error</th></tr></thead><tbody><tr><td>0</td><td>Error 0 (Empty pipe)</td></tr><tr><td>1</td><td>Error 1 (A/D Converter saturated)</td></tr><tr><td>2</td><td>Error 2 (Reference voltage too small)</td></tr><tr><td>3</td><td>Error 3 (Flowrate > 130%)</td></tr><tr><td>4</td><td>Error 4 (Ext. zero return)</td></tr><tr><td>5</td><td>Error 5 (Data corrupted)</td></tr><tr><td>6</td><td>Error 6 (Totalizer defective)</td></tr><tr><td>7</td><td>Error 7 (Positive reference voltage too large)</td></tr></tbody></table> | Bit | Error | 0 | Error 0 (Empty pipe) | 1 | Error 1 (A/D Converter saturated) | 2 | Error 2 (Reference voltage too small) | 3 | Error 3 (Flowrate > 130%) | 4 | Error 4 (Ext. zero return) | 5 | Error 5 (Data corrupted) | 6 | Error 6 (Totalizer defective) | 7 | Error 7 (Positive reference voltage too large) |
| Bit | Error | | | | | | | | | | | | | | | | | | | |
| 0 | Error 0 (Empty pipe) | | | | | | | | | | | | | | | | | | | |
| 1 | Error 1 (A/D Converter saturated) | | | | | | | | | | | | | | | | | | | |
| 2 | Error 2 (Reference voltage too small) | | | | | | | | | | | | | | | | | | | |
| 3 | Error 3 (Flowrate > 130%) | | | | | | | | | | | | | | | | | | | |
| 4 | Error 4 (Ext. zero return) | | | | | | | | | | | | | | | | | | | |
| 5 | Error 5 (Data corrupted) | | | | | | | | | | | | | | | | | | | |
| 6 | Error 6 (Totalizer defective) | | | | | | | | | | | | | | | | | | | |
| 7 | Error 7 (Positive reference voltage too large) | | | | | | | | | | | | | | | | | | | |

6.16 E2 - Error Register 2

Function Characters: **E2**

Parameter/Function: Error Register 2

Units: -

Comments: Output the contents of the Error Register 2.

Monitor Mode

| Data | | Comments | | | | | | | | | | | | | | | | | | |
|--------|---|--|-----|-------|---|--|---|--------------------------|---|---|---|---------------------------------------|---|----------------------------------|---|--|---|---|---|---|
| Format | Number | | | | | | | | | | | | | | | | | | | |
| I | 3 | The contents of the Error Register are outputted in coded form. The individual errors are identified by the Bit: | | | | | | | | | | | | | | | | | | |
| | | <table border="1"> <thead> <tr> <th>Bit</th> <th>Error</th> </tr> </thead> <tbody> <tr> <td>0</td> <td>Error 8 (Negative reference voltage too large)</td> </tr> <tr> <td>1</td> <td>Error 9 (Line frequency)</td> </tr> <tr> <td>2</td> <td>-</td> </tr> <tr> <td>3</td> <td>Error B (Pulse calculation incorrect)</td> </tr> <tr> <td>4</td> <td>Error C (Primary data incorrect)</td> </tr> <tr> <td>5</td> <td>Function test active, converter is not on-line</td> </tr> <tr> <td>6</td> <td>Error 6 Forward (forward direction totalizer defective)</td> </tr> <tr> <td>7</td> <td>Error 6 Reverse (reverse direction totalizer defective)</td> </tr> </tbody> </table> | Bit | Error | 0 | Error 8 (Negative reference voltage too large) | 1 | Error 9 (Line frequency) | 2 | - | 3 | Error B (Pulse calculation incorrect) | 4 | Error C (Primary data incorrect) | 5 | Function test active, converter is not on-line | 6 | Error 6 Forward (forward direction totalizer defective) | 7 | Error 6 Reverse (reverse direction totalizer defective) |
| Bit | Error | | | | | | | | | | | | | | | | | | | |
| 0 | Error 8 (Negative reference voltage too large) | | | | | | | | | | | | | | | | | | | |
| 1 | Error 9 (Line frequency) | | | | | | | | | | | | | | | | | | | |
| 2 | - | | | | | | | | | | | | | | | | | | | |
| 3 | Error B (Pulse calculation incorrect) | | | | | | | | | | | | | | | | | | | |
| 4 | Error C (Primary data incorrect) | | | | | | | | | | | | | | | | | | | |
| 5 | Function test active, converter is not on-line | | | | | | | | | | | | | | | | | | | |
| 6 | Error 6 Forward (forward direction totalizer defective) | | | | | | | | | | | | | | | | | | | |
| 7 | Error 6 Reverse (reverse direction totalizer defective) | | | | | | | | | | | | | | | | | | | |

6.17 EM - Error Log Register Reset

Function Characters: **EM**

Parameter/Function: Reset Error Log Register

Units: -

Comments: This command is utilized to reset the Error Registers („6.30 L1 - Error Log Register 1”, and „6.31 L2 - Error Log Register 2”).

Programming Mode

| Data | | Data Range | Error Message | | Comments |
|--------|--------|------------|---------------|-------|----------|
| Format | Number | | No. | Cause | |
| - | 0 | - | - | - | - |

ASCII-Communication COPA-XF

6.18 FI - Stop Batch Cycle

Function Characters: **FI**

Parameter/Function: Stop batch cycle

Units: -

Comments: Only for Operating Mode „Batch 5kHz”.

Programming Mode

| Data | | Data Range | Error Message | | Comments |
|--------|--------|------------|---------------|-------|---|
| Format | Number | | No. | Cause | |
| - | 0 | - | - | - | Stop the batch cycle. The status of the batch cycle is indicated by Bit 6 in the Status Register („6.52 ST - Status Register”). |

6.19 FR - Flow Direction

Function Characters: **FR**

Parameter/Function: Flow direction

Units: -

Comments: The command changes the setting of Bit 4 in Mode Register 1 (M1 - Mode Register).

Programming Mode

| Data | | Data Range | Error Message | | Comments | |
|--------|--------|------------------------------|---------------|-----------------------------|----------|-----------------|
| Format | Number | | No. | Cause | Data | Explanation |
| I | 3 | $0 \leq \text{Entry} \leq 1$ | 99 | Entry outside of data range | 0 | Forward/Reverse |
| | | | | | 1 | Forward only |

6.20 IA - Alarm Current

Function Characters: **IA**

Parameter/Function: Alarm current value

Units: -

Comments: The value the alarm current is set to during an error condition for the current output. This parameter is only available in converters which include a current output option (Versions 05, 07, 08, 10, 20 and 23) and whose Operating Mode is set for continuous flowrate measurements ("Standard conti.", "Conti 1kHz", "Conti 2kHz" oder "Conti 5kHz").

Monitor Mode

| Data | | Comments | |
|--------|--------|----------|---|
| Format | Number | Data | Alarm Current |
| I | 3 | 0 | 0% of the current output range setting. |
| | | 1 | 130% of the current output range setting. |
| | | 2 | 3.6 mA |

Programming Mode

| Data | | Data Range | Error Message | | Comments |
|--------|--------|------------------------------|---------------|-----------------------------|---|
| Format | Number | | No. | Cause | |
| I | 3 | $0 \leq \text{Entry} \leq 2$ | 99 | Entry outside of data range | A alarm current value of 3.6 mA can only be selected when the current output range IO is set for "4-20 mA" or "4-12-20 mA". |

ASCII-Communication COPA-XF

6.21 IB - Pulse Width

Function Characters: **IB**

Parameter/Function: Pulse width for the scaled pulse output

Units: ms

Comments:

Monitor Mode

| Data | | Comments |
|--------|--------|--|
| Format | Number | |
| F | 6 | Pulse width for the scaled pulse output in ms. |

Programming Mode

| Data | | Data Range | Error Message | | Comments |
|--------|--------|-----------------------------------|---------------|-----------------|---|
| Format | Number | | No. | Cause | |
| F | 6 | $0.1 \leq \text{Entry} \leq 2000$ | 42 | Entry > 2000 | The Error Message "Entry too large" is set when the entry value is greater than 130% of half period of the pulse output frequency at 100% flowrate. |
| | | | 43 | Entry < 0.1 | |
| | | | 46 | Entry too large | |

6.22 IO - Current Output Range

Function Characters: **IO**

Parameter/Function: Current output range

Units: -

Comments: This command is only available in converters which include a current output option (Versions 05, 07, 08, 10, 20 and 23) and whose Operating Mode is set for continuous flowrate measurements ("Standard conti.", "Conti 1kHz", "Conti 2kHz" oder "Conti 5kHz").

Monitor Mode

| Data | | Comments | |
|--------|--------|-------------|-----------------------------|
| Format | Number | | |
| I | 3 | Data | Current Output Range |
| | | 0 | 0 - 20 mA |
| | | 1 | 4 - 20 mA |
| | | 2 | 0 - 10 mA |
| | | 3 | 2 - 10 mA |
| | | 4 | 0 - 5 mA |
| | | 5 | 0 - 10 - 20 mA |
| | | 6 | 4 - 12 - 20 mA |

Programming Mode

| Data | | Data Range | Error Message | | Comments |
|--------|--------|------------------------------|---------------|-----------------------------|-------------------|
| Format | Number | | No. | Cause | |
| I | 3 | $0 \leq \text{Entry} \leq 6$ | 99 | Entry outside of data range | See Monitor Mode. |

ASCII-Communication COPA-XF

6.23 I> - Pulse Factor

Function Characters: I>

Parameter/Function: Pulse factor

Units: 1 / [totalizer unit]

Comments:

Monitor Mode

| Data | | Comments |
|--------|--------|--|
| Format | Number | |
| F | 6 | Pulse factor in pulses/totalizer unit. |

Programming Mode

| Data | | Data Range | Error Message | | Comments |
|--------|--------|-------------------------------------|---------------|---------------------|---|
| Format | Number | | No. | Cause | |
| F | 6 | $0.001 \leq \text{Entry} \leq 1000$ | 38 | Entry > 1000 | The pulse factor can only be programmed in the Operating Modes "Standard conti." and "Standard Batch". In the other operating modes the entry will not be accepted. The "Frequency" is based on the scaled output frequency at 100% flowrate. |
| | | | 39 | Entry < 0.001 | |
| | | | 40 | Frequency > 5kHz | |
| | | | 41 | Frequency too small | |

6.24 K1 - Calibration 1

Function Characters: **K1**

Parameter/Function: Calibration factor for Batch 1

Units: %

Comments: The calibration applies to all operating modes. In the Operating Mode "Batch 5kHz", the calibration applies exclusively to Batch 1.

Monitor Mode

| Data | | Comments |
|--------|--------|--------------------------------|
| Format | Number | |
| F | 6 | Calibration factor in percent. |

Programming Mode

| Data | | Data Range | Error Message | | Comments |
|--------|--------|-------------------------------|---------------|-----------------------------|----------|
| Format | Number | | No. | Cause | |
| F | 6 | $-5 \leq \text{Entry} \leq 5$ | 58 | Entry outside of data range | - |

ASCII-Communication COPA-XF

6.25 K2 - Calibration 2

Function Characters: **K2**

Parameter/Function: Calibration factor for Batch 2

Units: %

Comments: Calibration 2 applies to Batch 2 for the Operating Mode "Batch 5kHz".
In the other operating modes this parameter has no effect.

Monitor Mode

| Data | | Comments |
|--------|--------|--------------------------------|
| Format | Number | |
| F | 6 | Calibration factor in percent. |

Programming Mode

| Data | | Data Range | Error Message | | Comments |
|--------|--------|-------------------------------|---------------|-----------------------------|----------|
| Format | Number | | No. | Cause | |
| F | 6 | $-5 \leq \text{Entry} \leq 5$ | 58 | Entry outside of data range | - |

6.26 K3 - Calibration 3

Function Characters: **K3**

Parameter/Function: Calibration factor for Batch 3

Units: %

Comments: Calibration 3 applies to Batch 3 for the Operating Mode "Batch 5kHz".
In the other operating modes this parameter has no effect.

Monitor Mode

| Data | | Comments |
|--------|--------|--------------------------------|
| Format | Number | |
| F | 6 | Calibration factor in percent. |

Programming Mode

| Data | | Data Range | Error Message | | Comments |
|--------|--------|-------------------------------|---------------|-----------------------------|----------|
| Format | Number | | No. | Cause | |
| F | 6 | $-5 \leq \text{Entry} \leq 5$ | 58 | Entry outside of data range | - |

6.27 LZ - Reset Totalizer

Function Characters: **LZ**

Reset totalizer and overflow counter

Units: -

Comments: This command resets the totalizer and overflow counter to 0.
In the Operating Mode „Batch 5kHz” the total flow totalizer Qg and the batch totalizer Q are reset.

Programming Mode

| Data | | Data Range | Error Message | | Comments |
|--------|--------|------------|---------------|-------|-------------------------------------|
| Format | Number | | No. | Cause | |
| - | - | - | - | - | No additional data are transmitted. |

ASCII-Communication COPA-XF

6.28 LV - Reset Difference Totalizer

Function Characters: **LV**

Parameter/Function: Reset difference totalizer and overflow counter

Units: -

Comments: This command resets the difference totalizer and overflow counter to 0.
In the Operating Mode „Batch 5kHz” the batch totalizer Q is reset.

Programming Mode

| Data | | Data Range | Error Message | | Comments |
|--------|--------|------------|---------------|-------|-------------------------------------|
| Format | Number | | No. | Cause | |
| - | - | - | - | - | No additional data are transmitted. |

6.29 LR - Reset Total Flow Totalizer

Function Characters: **LR**

Parameter/Function: Reset the total flow totalizer and overflow counter

Units: -

Comments: Only for Operating Mode „Batch 5kHz”: The total flow totalizer Qg is reset.

Programming Mode

| Data | | Data Range | Error Message | | Comments |
|--------|--------|------------|---------------|-------|-------------------------------------|
| Format | Number | | No. | Cause | |
| - | - | - | - | - | No additional data are transmitted. |

6.30 L1 - Error Log Register 1

Function Characters: **L1**

Parameter/Function: Error Register 1

Units: -

Comments: The register can be reset using the command EM („6.17 EM - Error Log Register reset“)

Monitor Mode

| Data | | Comments | | | | | | | | | | | | | | | | | | |
|--------|---------|--|-----|-------|---|---------|---|---------|---|---------|---|---------|---|---------|---|---------|---|---------|---|---------|
| Format | Number | | | | | | | | | | | | | | | | | | | |
| I | 3 | The contents of the Error Register are outputted in coded form. The individual errors are identified by the Bit: | | | | | | | | | | | | | | | | | | |
| | | <table border="1"> <thead> <tr> <th>Bit</th> <th>Error</th> </tr> </thead> <tbody> <tr> <td>0</td> <td>Error 0</td> </tr> <tr> <td>1</td> <td>Error 1</td> </tr> <tr> <td>2</td> <td>Error 2</td> </tr> <tr> <td>3</td> <td>Error 3</td> </tr> <tr> <td>4</td> <td>Error 4</td> </tr> <tr> <td>5</td> <td>Error 5</td> </tr> <tr> <td>6</td> <td>Error 6</td> </tr> <tr> <td>7</td> <td>Error 7</td> </tr> </tbody> </table> | Bit | Error | 0 | Error 0 | 1 | Error 1 | 2 | Error 2 | 3 | Error 3 | 4 | Error 4 | 5 | Error 5 | 6 | Error 6 | 7 | Error 7 |
| Bit | Error | | | | | | | | | | | | | | | | | | | |
| 0 | Error 0 | | | | | | | | | | | | | | | | | | | |
| 1 | Error 1 | | | | | | | | | | | | | | | | | | | |
| 2 | Error 2 | | | | | | | | | | | | | | | | | | | |
| 3 | Error 3 | | | | | | | | | | | | | | | | | | | |
| 4 | Error 4 | | | | | | | | | | | | | | | | | | | |
| 5 | Error 5 | | | | | | | | | | | | | | | | | | | |
| 6 | Error 6 | | | | | | | | | | | | | | | | | | | |
| 7 | Error 7 | | | | | | | | | | | | | | | | | | | |

ASCII-Communication COPA-XF

6.31 L2 - Error Log Register 2

Function Characters: **L2**

Parameter/Function: Error - Register 2

Units: -

Comments: The register can be reset using the command EM („6.17 EM - Error Log Register reset“)

Monitor Mode

| Data | | Comments | | | | | | | | | | | | | | | | | | |
|--------|---------|--|-----|-------|---|---------|---|---------|---|---|---|---------|---|---------|---|---|---|---|---|---|
| Format | Number | | | | | | | | | | | | | | | | | | | |
| I | 3 | The contents of the Error Register are outputted in coded form. The individual errors are identified by the Bit: <table border="1" data-bbox="284 943 1442 1254"><thead><tr><th>Bit</th><th>Error</th></tr></thead><tbody><tr><td>0</td><td>Error 8</td></tr><tr><td>1</td><td>Error 9</td></tr><tr><td>2</td><td>-</td></tr><tr><td>3</td><td>Error B</td></tr><tr><td>4</td><td>Error C</td></tr><tr><td>5</td><td>-</td></tr><tr><td>6</td><td>-</td></tr><tr><td>7</td><td>-</td></tr></tbody></table> | Bit | Error | 0 | Error 8 | 1 | Error 9 | 2 | - | 3 | Error B | 4 | Error C | 5 | - | 6 | - | 7 | - |
| Bit | Error | | | | | | | | | | | | | | | | | | | |
| 0 | Error 8 | | | | | | | | | | | | | | | | | | | |
| 1 | Error 9 | | | | | | | | | | | | | | | | | | | |
| 2 | - | | | | | | | | | | | | | | | | | | | |
| 3 | Error B | | | | | | | | | | | | | | | | | | | |
| 4 | Error C | | | | | | | | | | | | | | | | | | | |
| 5 | - | | | | | | | | | | | | | | | | | | | |
| 6 | - | | | | | | | | | | | | | | | | | | | |
| 7 | - | | | | | | | | | | | | | | | | | | | |

6.32 M - Instantaneous Flowrate

Function Characters: **M**

Parameter/Function: Output of the instantaneous flowrate value in % of Qmax.

Units: %

Comments: The 2nd function character is replaced in the response by the direction arrow:
> for forward, < for reverse.

WARNING!

It is preferable to interrogate the flowrate using the command MD.

Monitor Mode

| Data | | Comments |
|--------|--------|----------|
| Format | Number | |
| F | 6 | |

6.33 MD - Instantaneous Flowrate

Function Characters: **MD**

Parameter/Function: Output of the instantaneous flowrate value in % of Qmax.

Units: %

Comments: A negative value is outputted for the reverse flow direction.

Monitor Mode

| Data | | Comments |
|--------|--------|--|
| Format | Number | |
| F | 6 | Positive output value = forward Negative output value = reverse |

ASCII-Communication COPA-XF

6.34 MF - Averaging Factor

Function Characters: **MF**

Parameter/Function: Averaging factor

Units: -

Comments: Parameter for calculating the second stage flow correction factor for the Operating Mode "Batch 5kHz".

Monitor Mode

| Data | | Comments |
|--------|--------|----------|
| Format | Number | |
| I | 3 | |

Programming Mode

| Data | | Data Range | Error Message | | Comments |
|--------|--------|------------------------------|---------------|-----------------------------|----------|
| Format | Number | | No. | Cause | |
| I | 3 | $2 \leq \text{Entry} \leq 5$ | 99 | Entry outside of data range | |

6.35 MK - Calculate Secondary Flow Correction Mode

Function Characters: **MK**

Parameter/Function: Secondary flow correction mode

Units: -

Comments: Only for Operating Mode "Batch 5kHz".

Monitor Mode

| Data | | Comments | |
|--------|--------|-------------|--------------------------------|
| Format | Number | | |
| I | 3 | Data | Explanation |
| | | 000 | Manual |
| | | 001 | Calculate the averaging factor |

Programming Mode

| Data | | Data Range | Error Message | | Comments |
|--------|--------|------------------------------|---------------|-----------|----------|
| Format | Number | | No. | Cause | |
| I | 3 | $0 \leq \text{Entry} \leq 1$ | 99 | Entry > 1 | |

ASCII-Communication COPA-XF

6.36 MN - Measure Second Stage Flow Mode

Function Characters: **MN**

Parameter/Function: Measure second stage flow mode Qn

Units: -

Comments: Only for Operating Mode "Batch 5kHz".

Monitor Mode

| Data | | Comments | |
|--------|--------|----------|---|
| Format | Number | Data | Explanation |
| I | 3 | 000 | Measure until end of second stage time tn |
| | | 001 | Measure until valve close time |
| | | | |

Programming Mode

| Data | | Data Range | Error Message | | Comments |
|--------|--------|------------------------------|---------------|-----------|----------|
| Format | Number | | No. | Cause | |
| I | 3 | $0 \leq \text{Entry} \leq 1$ | 99 | Entry > 1 | |

6.37 M1 - Mode Register 1

Function Characters: **M1**

Parameter/Function: Mode Register 1

Units: -

Comments: The register is read only. In order to make a change, the corresponding functions/parameters must be explicitly reprogrammed.

Monitor Mode

| Data | | Comments | | | | | | | | | | | | | | | | | | |
|--------|--|---|-----|-------------|---|--|---|---|---|--|---|--|---|--|---|---|---|-------------|---|-------------|
| Format | Number | | | | | | | | | | | | | | | | | | | |
| I | 3 | The contents of this register are outputted in coded form: <table border="1" style="width: 100%; border-collapse: collapse; margin-top: 10px;"> <thead> <tr> <th style="text-align: center;">Bit</th> <th style="text-align: left;">Explanation</th> </tr> </thead> <tbody> <tr> <td style="text-align: center;">0</td> <td>Empty pipe detector 0 = off 1 = on</td> </tr> <tr> <td style="text-align: center;">1</td> <td>Direction indication 0 = normal 1 = inverse</td> </tr> <tr> <td style="text-align: center;">2</td> <td>QmaxDN Mode 0 = fixed 1 = programmable</td> </tr> <tr> <td style="text-align: center;">3</td> <td>Signal measurement mode 0 = fast 1 = Offset correction</td> </tr> <tr> <td style="text-align: center;">4</td> <td>Flow direction to be measured 0 = Forward/reverse 1 = Forward only</td> </tr> <tr> <td style="text-align: center;">5</td> <td>QmaxDN velocity 0 = 10 m/s 1 = 33.33 ft/s</td> </tr> <tr> <td style="text-align: center;">6</td> <td>No function</td> </tr> <tr> <td style="text-align: center;">7</td> <td>No function</td> </tr> </tbody> </table> | Bit | Explanation | 0 | Empty pipe detector 0 = off 1 = on | 1 | Direction indication 0 = normal 1 = inverse | 2 | QmaxDN Mode 0 = fixed 1 = programmable | 3 | Signal measurement mode 0 = fast 1 = Offset correction | 4 | Flow direction to be measured 0 = Forward/reverse 1 = Forward only | 5 | QmaxDN velocity 0 = 10 m/s 1 = 33.33 ft/s | 6 | No function | 7 | No function |
| Bit | Explanation | | | | | | | | | | | | | | | | | | | |
| 0 | Empty pipe detector 0 = off 1 = on | | | | | | | | | | | | | | | | | | | |
| 1 | Direction indication 0 = normal 1 = inverse | | | | | | | | | | | | | | | | | | | |
| 2 | QmaxDN Mode 0 = fixed 1 = programmable | | | | | | | | | | | | | | | | | | | |
| 3 | Signal measurement mode 0 = fast 1 = Offset correction | | | | | | | | | | | | | | | | | | | |
| 4 | Flow direction to be measured 0 = Forward/reverse 1 = Forward only | | | | | | | | | | | | | | | | | | | |
| 5 | QmaxDN velocity 0 = 10 m/s 1 = 33.33 ft/s | | | | | | | | | | | | | | | | | | | |
| 6 | No function | | | | | | | | | | | | | | | | | | | |
| 7 | No function | | | | | | | | | | | | | | | | | | | |

ASCII-Communication COPA-XF

6.38 M2 - Mode Register 2

Function Characters: **M2**

Parameter/Function: Mode Register 2

Units: -

Comments: The register is read only. In order to make a change, the corresponding functions/parameters must be explicitly reprogrammed.

Monitor Mode

| Data | | Comments | | | | | | | | | | | | | | | | | | |
|--------|---|--|-----|-------------|---|-------------|---|---------------------------------------|---|---|---|---|---|-------------|---|-------------|---|-------------|---|-------------|
| Format | Number | | | | | | | | | | | | | | | | | | | |
| I | 3 | The contents of this register are outputted in coded form: <table border="1"><thead><tr><th>Bit</th><th>Explanation</th></tr></thead><tbody><tr><td>0</td><td>No function</td></tr><tr><td>1</td><td>Power supply type 0 = AC 1 = DC</td></tr><tr><td>2</td><td>Allowable lower measurement range (Range < 0.05 RangeDN) 0 = No (i.e. greater than 0.05 QmaxDN) 1 = Yes</td></tr><tr><td>3</td><td>Empty pipe detector signal 0 = Off 1 = On</td></tr><tr><td>4</td><td>No function</td></tr><tr><td>5</td><td>No function</td></tr><tr><td>6</td><td>No function</td></tr><tr><td>7</td><td>No function</td></tr></tbody></table> | Bit | Explanation | 0 | No function | 1 | Power supply type 0 = AC 1 = DC | 2 | Allowable lower measurement range (Range < 0.05 RangeDN) 0 = No (i.e. greater than 0.05 QmaxDN) 1 = Yes | 3 | Empty pipe detector signal 0 = Off 1 = On | 4 | No function | 5 | No function | 6 | No function | 7 | No function |
| Bit | Explanation | | | | | | | | | | | | | | | | | | | |
| 0 | No function | | | | | | | | | | | | | | | | | | | |
| 1 | Power supply type 0 = AC 1 = DC | | | | | | | | | | | | | | | | | | | |
| 2 | Allowable lower measurement range (Range < 0.05 RangeDN) 0 = No (i.e. greater than 0.05 QmaxDN) 1 = Yes | | | | | | | | | | | | | | | | | | | |
| 3 | Empty pipe detector signal 0 = Off 1 = On | | | | | | | | | | | | | | | | | | | |
| 4 | No function | | | | | | | | | | | | | | | | | | | |
| 5 | No function | | | | | | | | | | | | | | | | | | | |
| 6 | No function | | | | | | | | | | | | | | | | | | | |
| 7 | No function | | | | | | | | | | | | | | | | | | | |

6.39 NG - System Zero

Function Characters: **NG**

Parameter/Function: System zero

Units: Hz

Comments: A negative system zero value indicates reverse flow.

Monitor Mode

| Data | | Comments |
|--------|--------|----------|
| Format | Number | |
| F | 6 | - |

Programming Mode

| Data | | Data Range | Error Message | | Comments |
|--------|--------|---------------------------------|---------------|-----------------------------|----------|
| Format | Number | | No. | Cause | |
| F | 6 | $-50 \leq \text{Entry} \leq 50$ | 54 | Entry outside of data range | - |

ASCII-Communication COPA-XF

6.40 NK - Second Stage Flow Correction Quantity

Function Characters: **NK**

Parameter/Function: Second stage flow correction quantity

Units: Units Totalizer (EZ)

Comments: Only for Operating Mode "Batch 5kHz".

Monitor Mode

| Data | | Comments |
|--------|--------|---|
| Format | Number | |
| F | 6 | The present second stage flow correction quantity is outputted. |

Programming Mode

| Data | | Data Range | Error Message | | Comments |
|--------|--------|---------------------------------|---------------|----------------|---|
| Format | Number | | No. | Cause | |
| F | 6 | $-50 \leq \text{Entry} \leq 50$ | 54 | Entry ≥ 0 | For a "Manual Second Stage Flow Correction" (see „6.35 MK - Calculate Second Stage Flow Correction") the entry has a direct effect on the second stage flow correction. If the second stage flow correction is calculated by the converter (Averaging), then this value is the starting value after a reset (mains interrupt) of the converter. |

6.41 NM - Second Stage Flow Quantity

Function Characters: **NM**

Parameter/Function: Second stage flow quantity

Units: Units Totalizer (EZ)

Comments: Only for Operating Mode "Batch 5kHz".

Monitor Mode

| Data | | Comments |
|--------|--------|--|
| Format | Number | |
| F | 6 | A negative value indicates reverse flow. |

6.42 NW - Meter Size

Function Characters: **NW**

Parameter/Function: Flowmeter primary meter size

Units: -

Comments:

Monitor Mode

| Data | | Comments | |
|--------|--------|-------------|--------------------|
| Format | Number | | |
| I | 3 | Data | Explanation |
| | | 000 | DN 3 1/8" |
| | | 001 | DN 4 5/32" |
| | | 002 | DN 5 3/16" |
| | | 003 | DN 6 1/4" |
| | | 004 | DN 8 5/16" |
| | | 005 | DN 10 3/8" |
| | | 006 | DN 15 1/2" |
| | | 007 | DN 20 3/4" |
| | | 008 | DN 25 1" |
| | | 009 | DN 32 1-1/4" |
| | | 010 | DN 40 1-1/2" |
| | | 011 | DN 50 2" |
| | | 012 | DN 65 2-1/2" |
| | | 013 | DN 80 3" |
| | | 014 | DN 100 4" |

Programming Mode

| Data | | Data Range | Error Message | | Comments |
|--------|--------|-------------------------------|---------------|------------|--|
| Format | Number | | No. | Cause | |
| I | 3 | $0 \leq \text{Entry} \leq 14$ | 99 | Entry > 14 | When the meter size is programmed the parameters QmaxDN, Qmax, Pulse Factor, Units Qmax, Units Totalizer and Density are affected. Therefore the meter size should be programmed prior to programming the parameters listed above. |

ASCII-Communication COPA-XF

6.43 NZ - Second Stage Time

Function Characters: **NZ**

Parameter/Function: Second stage time

Units: s

Comments: Only for Operating Mode "Batch 5kHz". The second stage flow is measured during the second stage time.

Monitor Mode

| Data | | Comments |
|--------|--------|----------|
| Format | Number | |
| F | 6 | |

Programming Mode

| Data | | Data Range | Error Message | | Comments |
|--------|--------|-------------------------------|---------------|-----------------------------|---|
| Format | Number | | No. | Cause | |
| F | 6 | $0 \leq \text{Entry} \leq 10$ | 99 | Entry outside of data range | The entry is internally converted in 40 ms steps. |

6.44 O< - Forward Overflow Counter

Function Characters: **O<**

Parameter/Function: Forward overflow counter

Units: -

Comments: An overflow corresponds to 10,000,000 [totalizer units]

Monitor Mode

| Data | | Comments |
|--------|--------|--|
| Format | Number | |
| I | 3 | The overflow counter can be reset with the command LZ (reset totalizer). |

6.45 O< - Reverse Overflow Counter

Function Characters: **O<**

Parameter/Function: Reverse overflow counter

Units: -

Comments: An overflow corresponds to 10,000,000 [totalizer units]

Monitor Mode

| Data | | Comments |
|--------|--------|--|
| Format | Number | |
| I | 3 | The overflow counter can be reset with the command LZ (reset totalizer). |

ASCII-Communication COPA-XF

6.46 PR - Program Version

Function Characters: **PR**

Parameter/Function: Program Version/Revision

Units: -

Comments:

Monitor Mode

| Data | | Comments |
|--------|--------|--|
| Format | Number | |
| A | 8 | Output in ASCII-Code. e.g.: "B181 B20" B181 = Software D699B181U01 (Standard software COPA-XF) B20 = Revision B.20 |

6.47 Qn - Flowmeter Primary Constant QmaxDN

Function Characters: **QN**

Parameter/Function: Flowmeter primary constant QmaxDN

Units: 6.13 EI - Units Qmax

Comments: The output of QmaxDN. The flow velocity (10 m/s or 33.33 ft/s) can be read in the Mode Register 1 (M1).

Monitor Mode

| Data | | Comments |
|--------|--------|----------|
| Format | Number | |
| F | 7 | - |

6.48 Q> - Flow Range Qmax

Function Characters: **Q>**

Parameter/Function: Flow range Qmax

Units: Units Qmax (EI)

Comments: The flow range setting applies to both flow directions (forward and reverse).

Monitor Mode

| Data | | Comments |
|--------|--------|----------|
| Format | Number | |
| F | 7 | - |

Programming Mode

| Data | | Data Range | No. | Error Message | Comments |
|--------|--------|--------------------------|-----|---------------------|---|
| Format | Number | | | Cause | |
| F | 7 | 0.05 QmaxDNy ≤ QmaxDN | 10 | Entry > QmaxDN | The flow range is always based on the QmaxDN value. |
| | | | 11 | Entry < 0.05 QmaxDN | |

ASCII-Communication COPA-XF

6.49 RU - Start Batch

Function Characters: **RU**

Parameter/Function: Start batch cycle

Units: -

Comments: Only for Operating Mode „Batch 5kHz”.

Programming Mode

| Data | | Data Range | Error Message | | Comments |
|--------|--------|------------|---------------|-------|--|
| Format | Number | | No. | Cause | |
| - | 0 | - | - | - | During the batch cycle Bit 6 in Status Register 1 is set („6.52 ST - Status Register”) |

6.50 SM - Low Flow Cutoff

Function Characters: **SM**

Parameter/Function: Low flow cutoff value

Units: %

Comments: Low flow cutoff value in % of the flow range Qmax.

Monitor Mode

| Data | | Data Range | Error Message | | Comments |
|--------|--------|------------|---------------|-------|----------|
| Format | Number | | No. | Cause | |
| F | 6 | - | - | - | - |

Programming Mode

| Data | | Data Range | Error Message | | Comments |
|--------|--------|-------------------------------|---------------|------------|----------|
| Format | Number | | No. | Cause | |
| F | 6 | $0 \geq \text{Entry} \geq 10$ | 16 | Entry > 10 | - |
| | | | 17 | Entry < 0 | |

6.51 SP - Language

Function Characters: **SP**

Parameter/Function: Language (for display indications)

Units: -

Comments:

Monitor Mode

| Data | | Comments | |
|--------|--------|-------------|--|
| Format | Number | | |
| I | 3 | Data | Explanation |
| | | 000 | German |
| | | 001 | English |
| | | 002 | Swedish (only for Software Version D699B183U01 X.2x) |

Programming Mode

| Data | | Data Range | Error Message | | Comments |
|--------|--------|--------------------------------------|---------------|-----------------------------|---|
| Format | Number | | No. | Cause | |
| I | 3 | 0 ≤ Entry ≤ 1 or 0 ≤ Entry ≤ 2 | 99 | Entry outside of data range | In the Version D699B183U01 X.2x Swedish is implemented as an additional language. |

ASCII-Communication COPA-XF

6.52 ST - Status Register

Function Characters: **ST**

Parameter/Function: Status Register 1

Units: -

Comments: Output of the Status Register 1 in coded form.

Monitor Mode

| Data | | Comments | |
|--------|--------|----------|---|
| Format | Number | Bit | Explanation |
| 1 | 3 | 0 | Difference totalizer-overflow forward direction |
| | | 1 | Difference totalizer-overflow reverse direction |
| | | 2 | - |
| | | 3 | Parameter changes using the keypad |
| | | 4 | An adjustment routine is presently active |
| | | 5 | Flowrate less than low flow cutoff value |
| | | 6 | Status End Contact in the Operating Mode „Batch“ |
| | | 7 | An error condition has been detected. Error see „Sect. 6.15 E1 - Error Register 1“ and „Sect. 6.16 E2 - Error Register 2“ |

6.53 S2 - Status Register 2

Function Characters: **S2**

Parameter/Function: Status Register 2

Units: -

Comments: Output of the Status Register 2 in coded form.

Monitor Mode

| Data | | Comments | |
|--------|--------|----------|---|
| Format | Number | | |
| I | 3 | | |
| | | Bit | Explanation |
| | | 0 | - |
| | | 1 | - |
| | | 2 | Present flow direction is forward. |
| | | 3 | - |
| | | 4 | Function test „Test Mode” (operation using simulator is active. |
| | | 5 | Is set after a power outage (Reset). |
| | | 6 | - |
| | | 7 | - |

ASCII-Communication COPA-XF

6.54 T1 - TAG Number (1)

Function Characters: **T1**

Parameter/Function: TAG Number 1

Units: -

Comments: The first 8 characters of the 16-character TAG Number

Monitor Mode

| Data | | Comments |
|--------|--------|--|
| Format | Number | |
| A | 8 | Alphanumeric output (letters, numbers, special characters) |

Programming Mode

| Data | | Data Range | Error Message | | Comments |
|--------|--------|--|---------------|-------|--|
| Format | Number | | No. | Cause | |
| A | 8 | Numbers 0..9 Letters a..z, A..Z Spec. char. -+/*/: space | - | - | The entry is not checked for data range. |

6.55 T2 - TAG Number (2)

Function Characters: **T2**

Parameter/Function: TAG Number 2

Units: -

Comments: The second 8 characters of the 16-character TAG Number

Monitor Mode

| Data | | Comments |
|--------|--------|--|
| Format | Number | |
| A | 8 | Alphanumeric output (letters, numbers, special characters) |

Programming Mode

| Data | | Data Range | Error Message | | Comments |
|--------|--------|--|---------------|-------|--|
| Format | Number | | No. | Cause | |
| A | 8 | Numbers 0...9 Letters a..z, A..Z Spec. char. -+/*/:. space | - | - | The entry is not checked for data range. |

ASCII-Communication COPA-XF

6.56 t1 - Maximum Batch Time 1

Function Characters: **t1**

Parameter/Function: Maximum batch time for Batch 1

Units: s

Comments: Only for Operating Mode „Batch 5kHz”

Monitor Mode

| Data | | Comments |
|--------|--------|---|
| Format | Number | |
| F | 6 | An output of 0s indicates that the: „Maximum Batch Time 1” is turned off. |

Programming Mode

| Data | | Data Range | Error Message | | Comments |
|--------|--------|---------------------------------|---------------|-----------------------------|--|
| Format | Number | | No. | Cause | |
| F | 6 | $0 \leq \text{Entry} \leq 2600$ | 99 | Entry outside of data range | An entry of 0s turns the „Maximum Batch Time 1” off. |

6.57 t2 - Maximum Batch Time 2

Function Characters: **t2**

Parameter/Function: Maximum batch time for Batch 2

Units: s

Comments: Only for Operating Mode „Batch 5kHz”.

Monitor Mode

| Data | | Comments |
|--------|--------|---|
| Format | Number | |
| F | 6 | An output of 0s indicates that the: „Maximum Batch Time 2” is turned off. |

Programming Mode

| Data | | Data Range | Error Message | | Comments |
|--------|--------|---------------------------------|---------------|-----------------------------|--|
| Format | Number | | No. | Cause | |
| F | 6 | $0 \leq \text{Entry} \leq 2600$ | 99 | Entry outside of data range | An entry of 0s turns the „Maximum Batch Time 2” off. |

ASCII-Communication COPA-XF

6.58 t3 - Maximum Batch Time 3

Function Characters: **t3**

Parameter/Function: Maximum batch time for Batch 3

Units: s

Comments: Only for Operating Mode „Batch 5kHz”

Monitor Mode

| Data | | Comments |
|--------|--------|---|
| Format | Number | |
| F | 6 | An output of 0s indicates that the: „Maximum Batch Time 3” is turned off. |

Programming Mode

| Data | | Data Range | Error Message | | Comments |
|--------|--------|---------------------------------|---------------|-----------------------------|--|
| Format | Number | | No. | Cause | |
| F | 6 | $0 \leq \text{Entry} \leq 2600$ | 99 | Entry outside of data range | An entry of 0s turns the „Maximum Batch Time 3” off. |

6.59 VZ - Valve Closing Time

Function Characters: **VZ**

Parameter/Function: Measured valve closing time tv

Units: Seconds

Comments: Only for Operating Mode „Batch 5kHz”

Monitor Mode

| Data | | Comments |
|--------|--------|--|
| Format | Number | |
| F | 6 | Output of the valve closing time in seconds The valve closing time is automatically measured by the converter. The valve closing time is defined as the elapsed time from the opening of the end contact until the flowrate is less than 1%. |

6.60 Z1 - Display Line 1

Function Characters: **Z1**

Parameter/Function: Process display for the 1st line

Units: -

Comments: The lower 4 bits converted to Hex data indicate the value to be displayed in the 1st line, the upper 4 bits the multiplexed function.

Example:

The output 112 = 70h indicates: 1st line display of [%], multiplex mode OFF.

Monitor Mode

| Data | | Comments | |
|--------|--------|---------------------|--|
| Format | Number | | |
| I | 3 | Data (Half-Byte) | Explanation |
| | | 0 | Q [%] (display the instantaneous flowrate in percent of Qmax) |
| | | 1 | Q [Units] (display of the instantaneous flowrate in engineering units ; Units see „Sect. 6.13 EI - Units Qmax”) |
| | | 2 | Display difference totalizer. Operating Mode „Batch 5kHz”: Display Qg (total flow totalizer) and Q (instantaneous batch totalizer). |
| | | 3 | Only for Operating Mode „Batch 5kHz”: Display total flow totalizer Qg |
| | | 4 | Only for Operating Mode „Batch 5kHz”: Display batch totalizer Q |
| | | 5 | Display „TAG Number” |
| | | 6 | Q [Bargraph] (display of the instantaneous flowrate as a bargraph) |
| | | 7 | Blank line or multiplex mode OFF. |

Programming Mode

| Data | | Data Range | Error Message | | Comments |
|--------|--------|------------------------------|---------------|-----------------------------|---|
| Format | Number | | No. | Cause | |
| I | 3 | $0 \leq \text{Entry} \leq 7$ | 99 | Entry outside of data range | There is no check made against the operating mode (Entry 3 and 4). WARNING! In the Programming Mode only the function „Line 1” is programmed. The function „Line 1 multiplex” is programmed with the command „Z3”! |

ASCII-Communication COPA-XF

6.61 Z2 - Display Line 2

Function Characters: **Z2**

Parameter/Function: Process display 2nd line

Units: -

Comments: The lower 4 bits converted to Hex data indicate the value to be displayed in the 1st line, the upper 4 bits the multiplexed function.

Example:

The output 112 = 70h indicates: 2nd line display of [%], multiplex mode OFF.

Monitor Mode

| Data | | Comments | |
|--------|--------|------------------|--|
| Format | Number | | |
| I | 3 | Data (Half-Byte) | Explanation |
| | | 0 | Q [%] (display the instantaneous flowrate in percent of Qmax) |
| | | 1 | Q [Units] (display of the instantaneous flowrate in engineering units ; Units see „Sect. 6.13 EI - Units Qmax“) |
| | | 2 | Display difference totalizer. Operating Mode „Batch 5kHz“: Display Qg (total flow totalizer) and Q (instantaneous batch totalizer). |
| | | 3 | Only for Operating Mode „Batch 5kHz“: Display total flow totalizer Qg |
| | | 4 | Only for Operating Mode „Batch 5kHz“: Display batch totalizer Q |
| | | 5 | Display „TAG Number“ |
| | | 6 | Q [Bargraph] (display of the instantaneous flowrate as a bargraph) |
| | | 7 | Blank line or multiplex mode OFF. |

Programming Mode

| Data | | Data Range | Error Message | | Comments |
|--------|--------|------------------------------|---------------|-----------------------------|---|
| Format | Number | | No. | Cause | |
| I | 3 | $0 \leq \text{Entry} \leq 7$ | 99 | Entry outside of data range | There is no check made against the operating mode (Entry 3 and 4). WARNING! In the Programming Mode only the function „Line 2“ is programmed. The function „Line 2 multiplex“ is programmed with the command „Z4“! |

6.62 Z3 - Display Line 1 Multiplex

Function Characters: **Z3**

Parameter/Function: 1st Display line multiplexed value in Multiplex Mode

Units: -

Comments: For codes see „6.60 Z1 - Display Line 1”.

Programming Mode

| Data | | Data Range | Error Message | | Comments |
|--------|--------|------------------------------|---------------|-----------------------------|----------|
| Format | Number | | No. | Cause | |
| I | 3 | $0 \leq \text{Entry} \leq 7$ | 99 | Entry outside of data range | - |

6.63 Z4 - Display Line 2 Multiplex

Function Characters: **Z4**

Parameter/Function: 2nd Display line multiplex value in Multiplex Mode

Units: -

Comments: For codes see „6.60 Z1 - Display Line 2”.

Programming Mode

| Data | | Data Range | Error Message | | Comments |
|--------|--------|------------------------------|---------------|-----------------------------|----------|
| Format | Number | | No. | Cause | |
| I | 3 | $0 \leq \text{Entry} \leq 7$ | 99 | Entry outside of data range | - |

ASCII-Communication COPA-XF

6.64 Z> - Difference Totalizer

Function Characters: **Z>**

Parameter/Function: Output difference totalizer or batch totalizer value

Units: See „Sect. 6.14 EZ - Units Totalizer“.

Comments: -

Monitor Mode

| Data | | Comments |
|--------|--------|---|
| Format | Number | |
| F | 7 | Output difference totalizer value. In the Operating Mode „Batch 5kHz“ the instantaneous batch totalizer value is outputted. To reset the totalizer see „6.27 LZ - Reset Totalizer“ and „6.28 LV - Reset Difference Totalizer“. |

6.65 Z< - Total Flow Totalizer

Function Characters: **Z<**

Parameter/Function: Output total flow totalizer value Qg

Units: See „Sect. 6.14 EZ - Units Totalizer“.

Comments: Only for Operating Mode „Batch 5kHz“. In the other Operating modes the output is undefined.
To reset totalizer see „6.27 LZ - Reset Totalizer“ and „6.28 LV - Reset Difference Totalizer“.

Monitor Mode

| Data | | Comments |
|--------|--------|----------|
| Format | Number | |
| F | 7 | - |



ABB Automation Products GmbH

Fischer & Porter

Dransfelder Str. 2

D-37079 Goettingen

Tel.: +49 (0) 5 51 9 05 - 0

Fax: +49 (0) 5 51 9 05 - 777

<http://www.bfp-ger.de>

