



Member of the FM Global Group

FM Approvals  
1151 Boston-Providence Turnpike  
P.O. Box 9102 Norwood, MA 02062 USA  
T: 781 762 4300 F: 781 762 9375 www.fmglobal.com

# CERTIFICATE OF COMPLIANCE

## HAZARDOUS LOCATION ELECTRICAL EQUIPMENT

This certificate is issued for the following equipment:

### **Model TTH300-ab, Temperature Transmitter**

IS/I,II,III/1/ABCDEFGH/ T\* ; — SAP\_214829; Entity; I/0/AEx ia IIC; T\*-SAP\_214829;NI/II/2/ABCD/ T\*; NI/2/II T\*=Ta=\*-SAP\_214831; S/II,III/2/EFG T\*.

Entity Parameters:

$V_{max}=30v$ ,  $I_{max}= 130mA$ ,  $P_{max}= 0.8W$   $C_i=5nF$ ,  $L_i=500\mu H$

Output Terminals(1,2,3,4,5 and 6)

Group AB  $V_{oc}=6.5v$ ,  $I_{sc}= 25.0mA$ ,  $P_o= 38mW$   $C_a=1.55\mu F$ ,  $L_a=5mH$

Group CD  $V_{oc}=6.5v$ ,  $I_{sc}= 25.0mA$ ,  $P_o= 38mW$   $C_a=8.75\mu F$ ,  $L_a=5mH$

Output Terminals (JP1)

$V_{oc}=6.2v$ ,  $I_{sc}= 65.2mA$ ,  $P_o= 101mW$   $C_a=1.4\mu F$ ,  $L_a=5mH$

NonIncendive Field Wiring parameters

$V_{max}=30v$ ,  $I_{max}= 130mA$ ,  $P_{max}= 0.8W$

a = Type of protection; L1 or L2.

b = Communication Protocol; H.

Special Conditions of Use:

1. The Model TTH300 must be used with an IP54 NRTL certified enclosure.
2. For Intrinsic Safety and Non Incendive Approvals the Temperature code and Ambient temperatures are as follows:  
T\*=Temperature Code T6 for a Maximum Ambient Temperature of 56°C.  
T\*=Temperature Code T5 for a Maximum Ambient Temperature of 71°C  
T\*=Temperature Code T4 for a Maximum Ambient Temperature of 85°C.

### **Model TTF300-abcd, Temperature Transmitter**

IS/I,II,III/1/ABCDEFGH/ T\* ; — SAP\_214832; Entity; I/0/AEx ia IIC; T\*-SAP\_214832;NI/II/2/ABCD/ T\*; NI/2/II T\*=Ta=\*-SAP\_214828; S/II,III/2/EFG T\*\*, XP/II/ABCD/ T\*; DIP/II,III/EFG/ T\*\*; Type 4X; IP66, IP67.

Entity Parameters:

$V_{max}=30v$ ,  $I_{max}= 130mA$ ,  $P_{max}= 0.8W$   $C_i=5nF$ ,  $L_i=500\mu H$

Output Terminals(1,2,3,4,5 and 6)

Group AB  $V_{oc}=6.5v$ ,  $I_{sc}= 25.0mA$ ,  $P_o= 38mW$   $C_a=1.55\mu F$ ,  $L_a=5mH$

Group CD  $V_{oc}=6.5v$ ,  $I_{sc}= 25.0mA$ ,  $P_o= 38mW$   $C_a=8.75\mu F$ ,  $L_a=5mH$

**Output Terminals (JP1)**

$V_{oc}=6.2v$ ,  $I_{sc}= 65.2mA$ ,  $P_o= 101mW$   $C_a=1.4\mu F$ ,  $L_a=5mH$

**NonIncendive Field Wiring parameters**

$V_{max}=30v$ ,  $I_{max}= 130mA$ ,  $P_{max}= 0.8W$

a = Type of protection; L1 or L2.

b = Housing/Display; A, B, C, D.

c = Cable Entry; 1,2,3.Certificates CS

d = Communication protocol; H.

**Special Conditions of Use:**

1. For Intrinsic Safety and Non Incendive Approvals the Temperature code and Ambient temperatures are as follows:

T\*=Temperature Code T6 for a Maximum Ambient Temperature of 44°C.

T\*=Temperature Code T5 for a Maximum Ambient Temperature of 56°C

T\*=Temperature Code T4 for a Maximum Ambient Temperature of 84°C.

2. For Explosionproof and Dust-Ignitionproof Approvals the Temperature code and Ambient temperatures are as follows:

T\*\*=Temperature Code T6 for a Maximum Ambient Temperature of 56°C.

T\*\*=Temperature Code T5 for a Maximum Ambient Temperature of 71°C

T\*\*=Temperature Code T4 for a Maximum Ambient Temperature of 85°C.

**Model TTH200-ab, Temperature Transmitter**

IS/I,II,III/1/ABCDEFG/ T\* ; — TTH200-L1H; Entity; I/O/AEx ia IIC; T\*-TTH200-L1H;NI/II/2/ABCD/ T\*; NI/2/II

T\*=Ta\*-.TTH200-L2H; S/II,III/2/EFG T\*.

**Entity Parameters:**

$V_{max}=30v$ ,  $I_{max}= 130mA$ ,  $P_{max}= 0.8W$   $C_i=5nF$ ,  $L_i=500\mu H$

**Output Terminals(1,2,3,4,5 and 6)**

Group AB  $V_{oc}=6.5v$ ,  $I_{sc}= 25.0mA$ ,  $P_o= 38mW$   $C_a=1.55\mu F$ ,  $L_a=5mH$

Group CD  $V_{oc}=6.5v$ ,  $I_{sc}= 25.0mA$ ,  $P_o= 38mW$   $C_a=8.75\mu F$ ,  $L_a=5mH$

**Output Terminals (JP1)**

$V_{oc}=6.2v$ ,  $I_{sc}= 65.2mA$ ,  $P_o= 101mW$   $C_a=1.4\mu F$ ,  $L_a=5mH$

**NonIncendive Field Wiring parameters**

$V_{max}=30v$ ,  $I_{max}= 130mA$ ,  $P_{max}= 0.8W$

a = Type of protection; L1 or L2.

b = Communication Protocol; H.

**Special Conditions of Use:**

1. The Model TTH200 must be used with an IP54 NRTL certified enclosure.

2. For Intrinsic Safety and Non Incendive Approvals the Temperature code and Ambient temperatures are as follows:

T\*=Temperature Code T6 for a Maximum Ambient Temperature of 56°C.

T\*=Temperature Code T5 for a Maximum Ambient Temperature of 71°C

T\*=Temperature Code T4 for a Maximum Ambient Temperature of 85°C.

**Model TTF350-abcdef, Temperature Transmitter**

IS/I,II,III/1/ABCDEFG/ T\* ; — TTF350-L4; Entity; I/O/AEx ia/IIC; T\*-TTF350-L4;NI/II/2/ABCD/ T\*;

NI/2/II T\*=Ta\*-.TTF350-L5; S/II,III/2/EFG T\*\*, XP/II/ABCD/ T\*; DIP/II,III/EFG/ T\*\*; Type 4X; IP66

IP67.

**Entity Parameters:**

$V_{max}=30v$ ,  $I_{max}= 130mA$ ,  $P_{max}= 0.8W$   $C_i=5nF$ ,  $L_i=500\mu H$

**Output Terminals(1,2,3,4,5 and 6)**

Group AB  $V_{oc}=6.5v$ ,  $I_{sc}= 25.0mA$ ,  $P_o= 38mW$   $C_a=1.55\mu F$ ,  $L_a=5mH$

Group CD  $V_{oc}=6.5v$ ,  $I_{sc}= 25.0mA$ ,  $P_o= 38mW$   $C_a=8.75\mu F$ ,  $L_a=5mH$

**Output Terminals (JP1)** $V_{oc}=6.2v$ ,  $I_{sc}= 65.2mA$ ,  $P_o= 101mW$   $C_a=1.4\mu F$ ,  $L_a=51mH$ **NonIncendive Field Wiring parameters** $V_{max}=30v$ ,  $I_{max}= 130mA$ ,  $P_{max}= 0.8W$ 

a = Type of protection; L3 or L4 or L5.

b = Housing/Display; N, or R.

c = Cable Entry; 5,6 or 8.

d = Communication protocol; H.

**Special Conditions of Use:**

1. For Intrinsic Safety and Non Incendive Approvals the Temperature code and Ambient temperatures are as follows:

T\*=Temperature Code T6 for a Maximum Ambient Temperature of 44°C.

T\*=Temperature Code T5 for a Maximum Ambient Temperature of 56°C

T\*=Temperature Code T4 for a Maximum Ambient Temperature of 84°C.

2. For Explosionproof and Dust-Ignitionproof Approvals the Temperature code and Ambient temperatures are as follows:

T\*\*=Temperature Code T6 for a Maximum Ambient Temperature of 56°C.

T\*\*=Temperature Code T5 for a Maximum Ambient Temperature of 71°C

T\*\*=Temperature Code T4 for a Maximum Ambient Temperature of 85°C.

**Equipment Ratings:**

The TTF350, TTH300, TTH200 and TTF300 Series Temperature Transmitters are FM Approved for Intrinsic Safety for Class I, II, III, Division 1, Groups A, B, C, D, E, F and G; Non Incendive for Class I, Division 2, Groups A, B, C, D and Suitable for Class II, III, Division 2, Groups E, and G when connected in conjunction with Control Drawings SAP\_214828, SAP\_214829, SAP\_214830, SAP\_214831, SAP\_214832, TTH200-L1H, TTH200-L2H, TTF350-L4...H(1), TTF350-L4...H(2), TTF350-L5...H(1) and TTF350-L5...H(2).

In addition, the TTF300 and TTF350 Temperature Transmitter is FM Approved for Explosionproof For Class I, Division 1, Groups A, B, C and D and Dust-Ignition Proof for Class II, III, Division 1, Groups E, F and G Hazardous(classified ) Locations Indoors and Outdoors Type 4X, IP66, IP67.

**FM Approved for:**

ABB Automation Products GmbH  
Alzenau, Germany

This certifies that the equipment described has been found to comply with the following Approval Standards and other documents:

Class 3600	1998
Class 3610	1999
Class 3611	2004
Class 3615	2006
Class 3616	1989
ISAS12.00.01	2002
Class 3810	2005
Nema 250	2003
IEC60529	2004

Original Project ID: 3027610

Approval Granted: January 5, 2007

Subsequent Revision Reports / Date Approval Amended

Report Number	Date	Report Number	Date
070801	November 2, 2007		
3028938	<i>DECEMBER 10, 2007</i>		

FM Approvals LLC

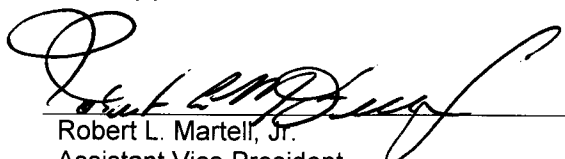



---

Robert L. Martell, Jr.  
Assistant Vice President

*DECEMBER 10, 2007*  
Date

## Hazardous Location

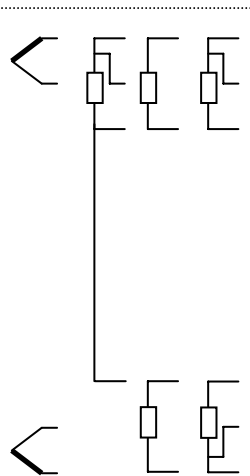
Sensors must be FM approved or be a simple apparatus. Simple apparatus is a device which will neither generate or store more than 1.5 V; 0.1 A; 25 mW or 20 μJ such as switches; RTD's, TC or LED's



Sensor Types Overview  
Channel 1 and 2  
RTD or TC or Voltage or ...

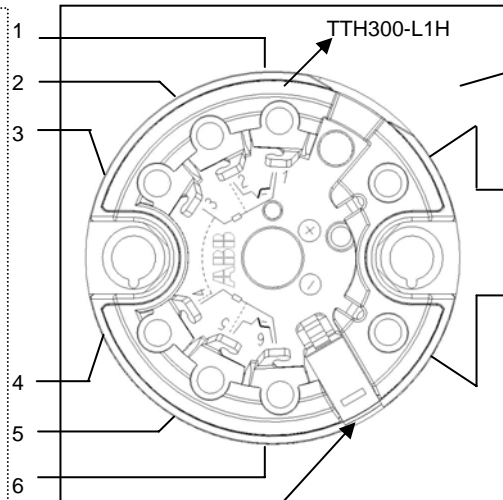

HMI / Display - Interface  
(Protection Cover, open with screw before connect !)

AGLF, AGSF,  
AGLFD, AGSFD  
Enclosure Type 4X

**Apparatus input Values**  
I. S. V max ≤ 30.0 V DC ;  
I max ≤ 130 mA ; Pi ≤ 0.8W  
Ci = 5nF Li = 0,5mH

## Non - Hazardous Location

**Barrier  
Galvanic Isolator**

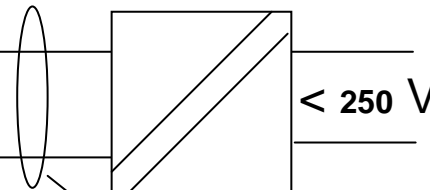

### Associated Apparatus

- Barrier or Galvanic Isolator must be FM approved and must be installed in accordance with manufactures instructions.
- Barrier or Galvanic Isolator parameters must meet the following Requirements :  
 $V_{oc}$  or  $V_t \leq V_{max}$ ;  $C_a \geq C_i + C_{cable}$ ;  
 $I_{sc}$  or  $I_t \leq I_{max}$ ;  $L_a \geq L_i + L_{cable}$   
 $P_o$  or  $P_t \leq P_{max}$
- Maximum non hazardous area voltage must not exceed 250V.
- Install in accordance with the NEC (ANSI/NFPA 70) and ANSI/ISA RP12.6. "Installation of intrinsically safe systems" Do not alter without FM authorization

### I.S. Sensor Field Circuit Parameters

$V_{oc} = 6.5 V$ ;  $I_{sc} < 25.0 mA$ ;  $P_o = 38 mW$   
 Tem. Ident. for Class I Div 1 and Div 2; Groups: A,B,C,D  
 $T_6$  at  $T_{amb} = 56 ^\circ C$ ;  $T_5$  at  $T_{amb} = 71 ^\circ C$ ;  $T_4$  at  $T_{amb} = 85 ^\circ C$ ;  
 Temp. Ident. for Class I Zone 0 AEx ia IIC  
 $T_6$  at  $T_{amb} = 44 ^\circ C$ ;  $T_5$  at  $T_{amb} = 56 ^\circ C$ ;  $T_4$  at  $T_{amb} = 84 ^\circ C$ ;  
 Terminals: 1,2,3,4,5,6 GP A,B  $C_a = 1.55 \mu F$ ;  $L_a = 5.0 mH$   
 C,D  $C_a = 8.75 \mu F$ ;  $L_a = 5.0 mH$

### HMI / Display Interface

**Intrinsically Safe output Parameters**  
 $V_{oc} = 6.2 V$ ;  $I_{sc} < 65.2 mA$ ;  $P_o = 101 mW$   
 Class I Div 1 and Div 2; ; Groups: A,B,C,D or  
 Class I Zone 0 AEx ia IIC  
 Terminals: 6 PIN Connector  
 GP A,B  $C_a = 1.4 \mu F$ ;  $L_a = 5.0 mH$   
 C,D  $C_a = 8.9 \mu F$ ;  $L_a = 5.0 mH$

Temperature Transmitter Model "TTF300"  
 Ordering Code "TTF300-L1..H" is an Temperature Transmitter Type TTH300-L1H, which is installed in an enclosure type AGLF, AGSF or AGLFD, AGSFD w/wo FM Approved display HMI-Ex type A

**Warning: Resistance between barrier ground and earth ground must be less then 1.0 Ohm!**

Rev.	Desc.	Date	Name
1.03	HART	17.07.07	Zeiger
1.02	FM Report	05.10.06	Zeiger
1.01	FM input	10.07.06	Zeiger
1.00	Release	23.05.06	Zeiger



Title:		TTF300 HART I.S. Temperature Transmitter Control Drawing		Scale:	-----
Drawing / Part No.:		<b>SAP_214832</b>		Page : of	1 / 1
Replacement of:		-----			

# Division 2 Hazardous Location

Sensors must be FM approved or be a simple apparatus. Simple apparatus is a device which will neither generate or store more than 1.5 V; 0.1 A; 25 mW or 20 μJ such as switches; RTD's, TC or LED's

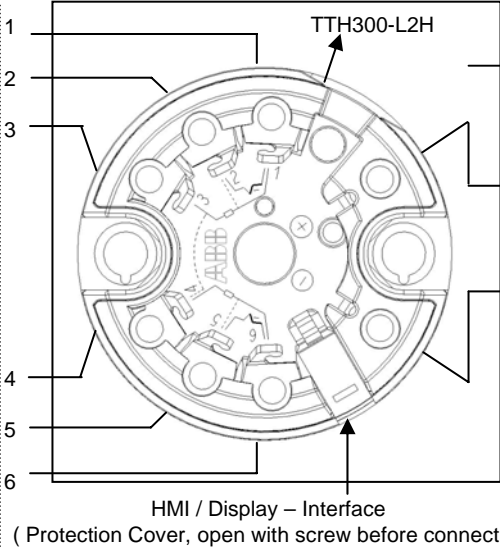
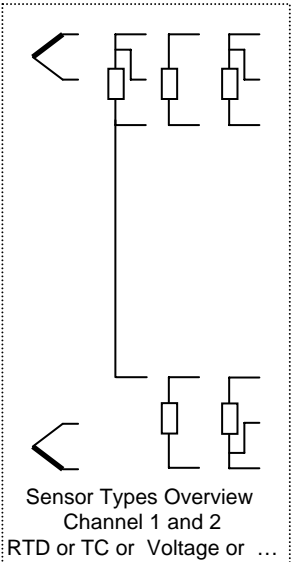

**Apparatus Input Values**  
N.I. V max ≤ 30.0 V ;  
I max ≤ 130 mA ; Pi ≤ 0,8W  
Ci = 5nF; Li = 0,5mH

# Non – Hazardous Location

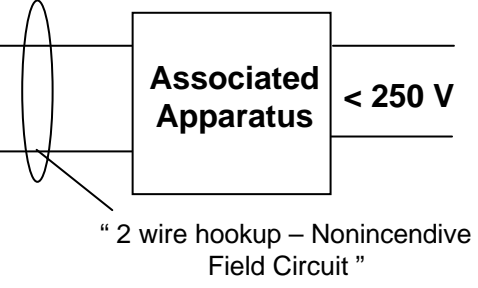

**Associated Apparatus**  
Nonincendive Parameters must meet the following Requirements :  
Voc or Vt ≤ Vmax; Ca ≥ Ci + Ccable;  
Isc or It ≤ I max; La ≥ Li + Lcable  
The temperature transmitter are FM approved for nonincendive field circuits when installed per national electrical code (NEC) article 501-4(B) or 502-4(B) exception with FM nonincendive field circuit output apparatus which meet the parameters shown on this drawings.  
  
Exception: Wiring in nonincendive circuits shall be permitted using any of the methods suitable for wiring in ordinary locations !

## Sensor Field Circuit Nonincendive Parameters

Voc = 6.5 V; Isc < 25.0 mA; Po = 38 mW  
Class I Div. 2; Groups:A,B,C,D or Class I Zone 2 Group IIC T6  
Temp.Ident: T6 at Tamb = 56 °C;  
T5 at Tamb = 71 °C;  
T4 at Tamb = 85 °C;  
Terminals: 1,2,3,4,5,6 GP A,B Ca = 1.55 μF; La = 5.0 mH  
C,D Ca = 8.75 μF; La = 5.0 mH

## HMI / Display Interface Non-incendive Output Parameters

Voc = 6.2 V; Isc < 65.2 mA; Po = 101 mW  
Terminals: 6 PIN Connector  
GP A,B Ca = 1.4 μF; La = 5.0 mH  
C,D Ca = 8.9 μF; La = 5.0 mH

Temperature Transmitter Model "TTF300"  
Ordering Code "TTF300-L2..H" is an Temp. Transmitter Type TTH300-L2H which is Installed in an enclosure type AGLF, AGSF or AGLFD, AGSFD w/wo FM approved display HMI-Ex type A..

Rev.	Desc.	Date	Name
1.03	HART	17.07.07	Zeiger
1.02	FM Report	05.10.06	Zeiger
1.01	FM input	10.07.06	Zeiger
1.00	Release	23.05.06	Zeiger

Title:		TTF300 HART N. I. Temperature Transmitter Control Drawing		Scale:	-----
Drawing / Part No.:		<b>SAP_214828</b>		Page : of	1 / 1
Replacement of:		-----			



Approv. 17.07.07 Müller  
Date Name

## Hazardous Location

Sensors must be FM approved or be a simple apparatus. Simple apparatus is a device which will neither generate or store more than 1.5 V; 0.1 A; 25 mW or 20 µJ such as switches; RTD's, TC or LED's

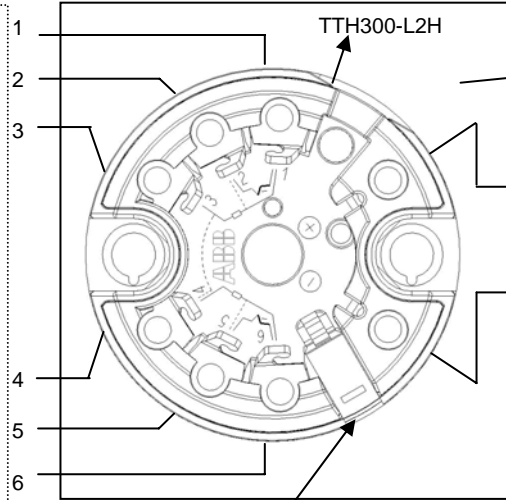
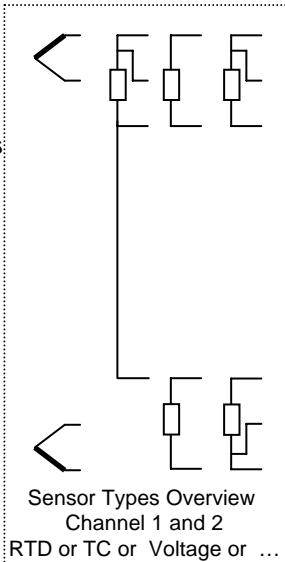

HMI / Display – Interface  
(Protection Cover, open with screw before connect !)

AGLF, AGSF, AGLFD,  
AGSFD Enclosure Type 4X

Apparatus Input Values  
V max <= 30.0 V ; I max <= 130 mA

## Non – Hazardous Location

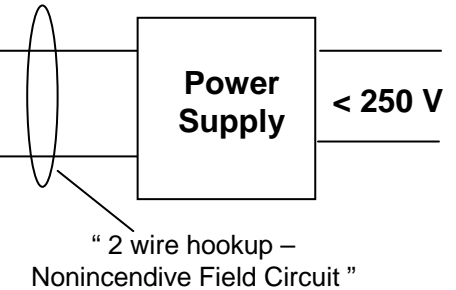

### Sensor Field Circuit Nonincendive Parameters

Class I Div. 2; Groups: A,B,C,D  
or Class 1 Zone 2 Group IIC T6  
Temp.Ident: T6 at Tamb = 56 °C;  
T5 at Tamb = 71 °C;  
T4 at Tamb = 85 °C;

Voc = 6.5 V; Isc < 25.0 mA; Po = 38 mW

Terminals: 1,2,3,4,5,6

GP A,B Ca = 1.55 µF; La = 5.0 mH

C,D Ca = 8.75 µF; La = 5.0 mH

### HMI / Display Interface

### Nonincendive Output Parameters

Voc = 6.2 V;  
Isc < 65.2 mA;  
Po = 101 mW  
Terminals: 6 PIN Connector  
GP A,B Ca = 1.4 µF; La = 5.0 mH  
C,D Ca = 8.9 µF; La = 5.0 mH

Nonincendive Class I Div.2 Groups A, B, C, D and suitable for Class II and III Div.2 Groups E,F,G Hazardous Location Installations.

1. Install per National Electrical Code (NEC) using Threaded Metal Conduit.
2. Warning:  
Explosion Hazard – Do not disconnect equipment unless power has been switched off, or the area is known to be non-hazardous.  
Warning: Substitution of components may impair suitability for class I Division 2.
3. A dust tight seal must be used at the conduit entry, when the transmitter is used in a class II & III Location.

Temperature Transmitter Model “TTF300” ordering code “TTF300-L2...” is an Temperature Transmitter Type TTH300-L2 which is installed in an enclosure type AGLF, AGSF , AGLFD or AGSFD w/wo FM approved display HMI-Ex type A

Rev.	Desc.	Date	Name
1.03	HART	17.07.07	Zeiger
1.02	FM-Report	05.10.06	Zeiger
1.01	FM input	10.07.06	Zeiger
1.00	Release	23.05.06	Zeiger

**ABB**  
Automation Products

Title:	TTF300 HART N. I. Temperature Transmitter Control Drawing	Scale:	-----
Drawing / Part No.:	<b>SAP_214830</b>	Page : of	1 / 1
Replacement of:	-----		