

# Thermal Waste Treatment

WTE Plant Linthgebiet, Switzerland

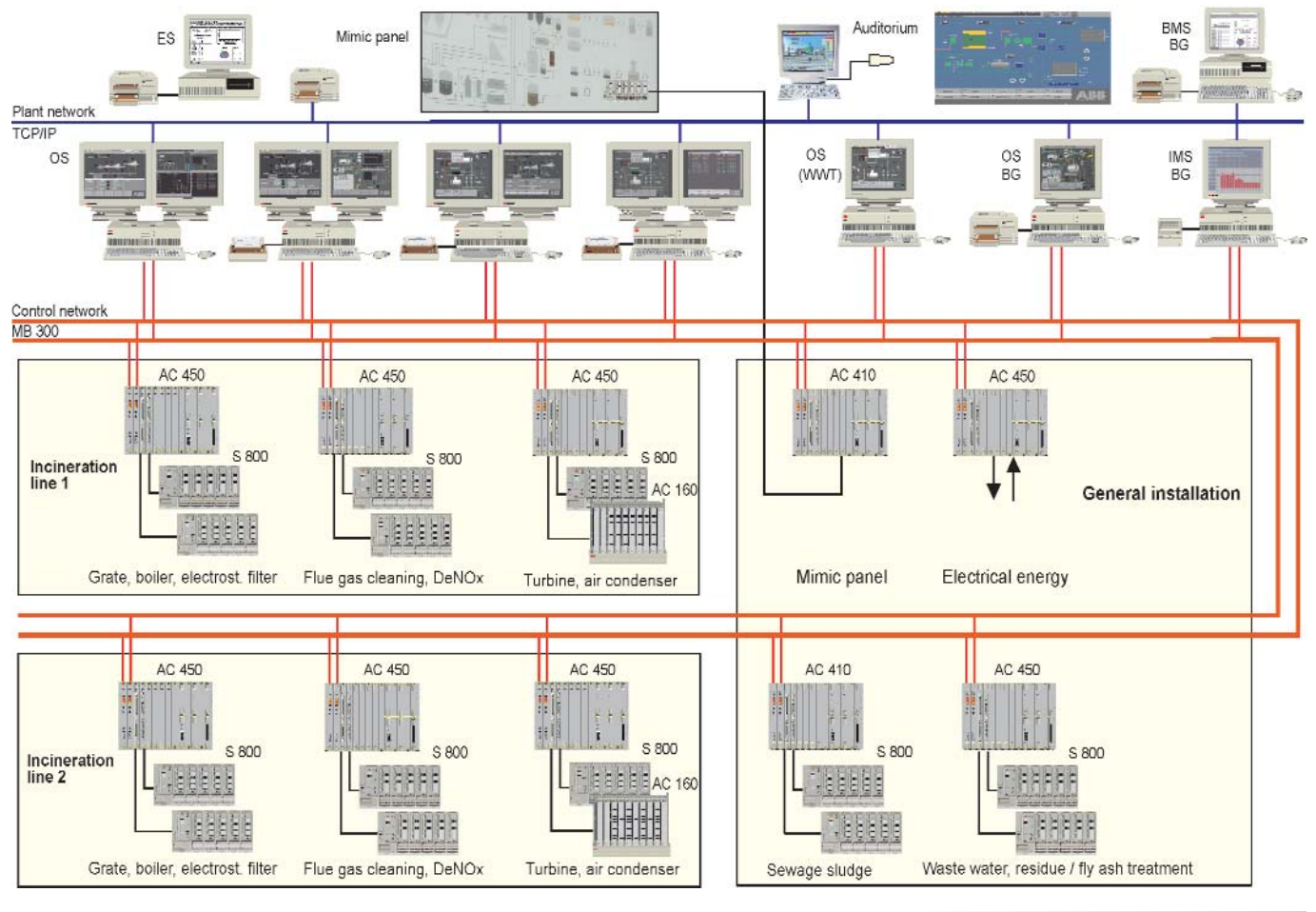

# WTE Plant Linthgebiet, Switzerland



## Plant data

Commissioning:	2000
Incineration lines:	2
Combustion capacity:	7.5 t/h / 7.5 t/h
Steam production:	420'800 MWh/a
Electricity:	95'000 MWh/a

## Operating data

Operator stations:	4 x OS 520 2 x OS 510
Info-Mgmt-System:	1 x IMS 500 1 x BMS 2000
Process stations:	8 x AC 450 red. 2 x AC 410
Central I/O:	S 100
Remote I/O:	S 800
Process signals:	10'000

## Scope of supply

- Process control system  
ABB Advant
- Boiler protection
- Instrumentation
- Medium voltage switchgear
- Transformers
- Frequency converter
- Low voltage switchgear
- Emission monitoring system
- Electrical installation
- Turbine controller
- Mimic panel

## Supervision



## Instrumentation



## Electrical equipment



## ABB Switzerland Ltd.

Power Systems  
Dept. PSPV  
Bruggerstrasse 72  
CH-5400 Baden, Switzerland  
Phone +41 (0)58 585 34 64  
Fax +41 (0)58 585 30 80  
e-mail: WTE@ch.abb.com  
www.abb.com/powergeneration