

The Hagfors SVC Light: a world first



An SVC Light rated at 10,5 kV, 0-44 Mvar supplied by ABB has been in operation since 1999 at the Uddeholm Tooling AB steel plant at Hagfors, Sweden. The SVC Light, which was installed on a Turnkey basis, has the purpose of mitigating flicker which emanates from the steel making process.

Said by the client:

»The SVC Light gives increased flexibility of the power system«

Uddeholm Tooling is a steel producer with its metallurgy based on scrap melting in an Electric Arc Furnace (EAF) and subsequent refining by means of a Ladle Furnace (LF). The EAF is rated at 31,5 MVA with a 20%

temporary overload capability, whereas the LF is rated at 6 MVA plus a 30% overload capability. Both furnaces are fed from a 132 kV grid via an intermediate voltage of 10,5 kV.

The feeding grid is relatively weak, with a fault level at the Point of Common Coupling which normally does not exceed 1000 MVA. This is a fault level quite insufficient to enable operation of the two furnaces while upkeeping reasonable power quality in the grid. Before the advent of the SVC Light, the Hagfors steel mill was a source of power quality problems, disturbing both surrounding power users as well as the mill itself.

With the SVC Light in operation, the residual flicker level at the PCC was projected not to exceed $Pst(95\%) = 1$. This target has been met.

As an additional benefit, the SVC Light installation has led to better furnace performance with regard to increased available melting power and a decrease of electrode consumption.

The SVC Light is rated at 0 - 44 Mvar of reactive power generation, continuously variable. This dynamic range is attained by means of a

Said by the client:

»The performance of the compensator has been excellent«

Voltage Source Converter (VSC) rated at 22 MVA in parallel with two harmonic filters, one rated at 14 Mvar, initially existing in the plant, and one installed as part of the SVC Light undertaking, rated at 8 Mvar. Via its phase reactors, the VSC is connected directly to the furnace bus voltage of 10,5 kV.

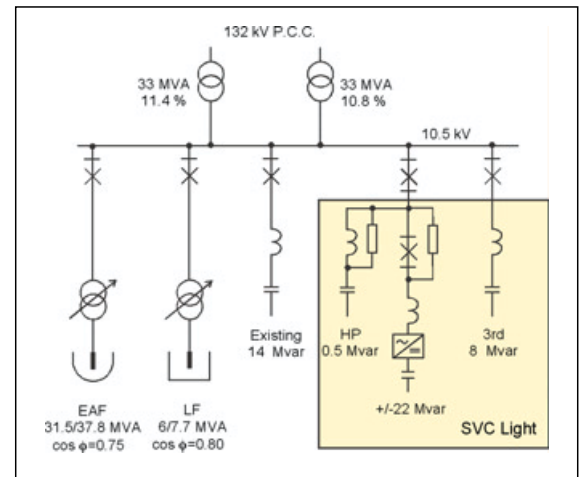

Single-line diagram

Voltage source converter

The input of the VSC is connected to a capacitor, which is acting as a DC voltage source. At the output, the converter is creating a variable AC voltage. This is done by connecting the positive pole, the midpoint, or the negative pole of the capacitor to any of the converter outputs.

As switching devices, IGBTs are utilized. Such devices allow connecting in series, thanks to low delay times for turn-on and turn-off. It has low switching losses and can thus be used at high switching frequencies. Pulse-Width Modulation (PWM) is utilized in the VSC, with a switching frequency in the kHz range. This provides a very smooth voltage output from the VSC.

The fast response of SVC Light furthermore enables its use as an active filter.

Powerful flicker mitigation

The targeted residual flicker level at the 132 kV point of common coupling with the SVC Light in operation has been aimed not to exceed $Pst(95\%) = 1$. With a measured flicker reduction factor around 3,5, this target has been fulfilled. The flicker diagram shows results from field measurements, without and with the SVC Light in operation.

The control system for flicker reduction is of open-loop type, for optimum speed of response. As an additional feature, a second, slower function for power factor control is included, as well. This feature permits a high and stable power factor of the plant at all times, with the power factor set at $P.F. > 0.95$.

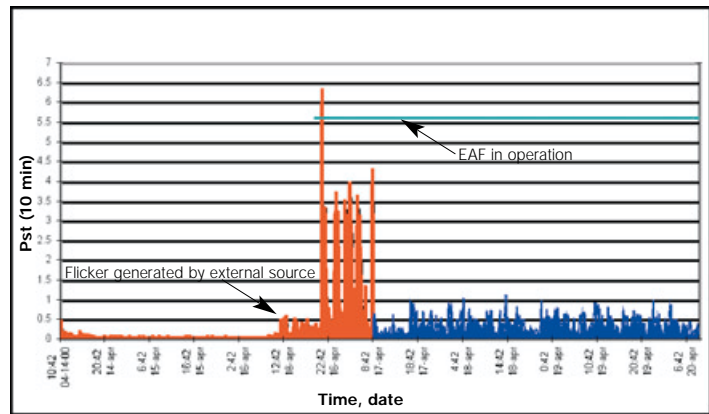

Flicker generation without and with SVC Light.

Productivity increase

Measurements have been performed of the active power consumption at the plant without and with dynamic compensation. Through dynamic compensation, the voltage at the furnace busbar is stabilised. The stabilised voltage increases the available furnace power.

Thus, the active power increase with SVC Light in operation gives a furnace production increase from 27,5 to 31,4 tonnes/hour. This increase is attained at a bus voltage of 10,5 kV. An even higher rise in active power into the furnace would be possible, but at a corresponding over-voltage at the 10 kV bus, which might be undesirable from the point of view of other equipment connected to the bus.

The increase of active power into the EAF enables a faster melt, and thereby a saving in specific energy consumption in the process derivable to lower specific radiation losses from the furnace. This saving accumulates over time, to the benefit of the plant operator. Thus, the energy saving achieved is around 25 kWh/tonne, equal to some 4% saving.

Said by the client:

»The SVC Light has lead to better furnace performance, with increased available power and less electrode consumption«

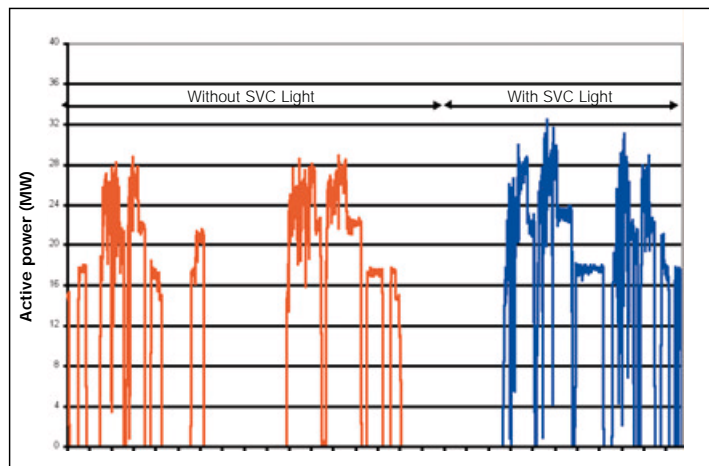

Active power into the EAF without and with dynamic compensation.

Likewise, a saving in specific electrode consumption of about 0,2 kg/tonne is attained.

Plant layout

All SVC Light equipment except the phase reactors and the harmonic filters is housed indoors in a small prefabricated building. The phase reactors and filters have been erected in a small, fenced outdoor yard. All in all, this gives a very compact layout of the installation.

Summary, technical data and operational benefits with SVC Light

Furnace bus voltage	10,5 kV
Rated power, EAF	31,5/37,8 MVA
Rated power, LF	6/7,7 MVA
Dynamic range, SVC Light	0 - 44 Mvar (capacitive)
Flicker reduction factor	~3,5
Attained flicker level at PCC with SVC Light in operation	Pst(95%) = 1
Power factor at PCC	P.F. > 0,95
Productivity increase	4 tonnes/hour
Specific electrode consumption decrease	0,2 kg/tonne
Specific energy consumption decrease	25 kWh/tonne

Said by the client:

»The SVC Light is also a pleasant solution because of its compactness...«



ABB Utilities AB
Power Systems
 S-721 64 Västerås
 Sweden
 Tel: +46 21 32 40 00
 Fax: +46 21 18 31 43
 E-mail: info.sepow@se.abb.com
www.abb.com/FACTS