

Substation Automation and Protection Division

Influence Of The Equal And Unequal CT Ratios On The Setting Of REL 356 Relays

Introduction

This application note will show how to calculate and pick the settings on the relay for the general application case, both CT at the two line end have the equal CT ratio, and CT's at two line ends have unequal ratios.

Application

Consider the line that is protected with REL356 relays at both ends like in Fig. 1

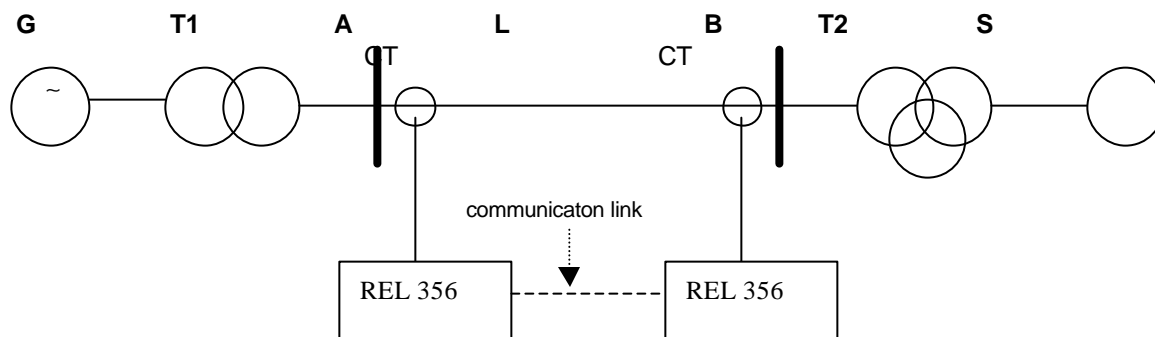

Figure 1 – Power system example for setting

The data that will be used in setting calculation is as follows:

G: Generator with nominal voltage of 13.8kV, nominal power 80MVA and impedance 16%,

T1: Two winding transformer with nominal power of 80MVA, nominal voltage 13.8/115kV, short-circuit impedance 11%, vector group delta – star,

L: Line of 30 miles length, positive and negative impedance is 24 Ohm and zero impedance is 82 Ohm,

T2: Three winding transformer with nominal power 150MVA, nominal voltage 230/115/13.2 kV with short circuit impedance $X_{hm}=5.5\%$, $X_{hl}=36\%$, $X_{ml}=28\%$, vector group star-star-delta,

S: System equivalent, nominal voltage is 230 kV, positive and negative impedance is 3%, zero impedance is 4%, all of them calculated at 100 MVA and 230 kV base.

The fault current distribution is presented in Table1.

Table 1 – System Fault Currents

FAULT	STATION A	STATION B
Three - phase	1484.3 A	2022.2 A
Phase to ground	2103.4 A	1661.6 A
Load	70 MVA	

For the given load of 70 MVA, nominal load current is:

$$I_n = S_n / (\sqrt{3} * U_n) = 70.000 / (\sqrt{3} * 115) = 351.4 \text{ A.}$$

Select current transformer with rated primary value of 400 A and rated secondary value of 5 A.

Equal CT ratio at both line ends

Setting for operating threshold (OTH):

The operating threshold determines the differential current required for operation according to the formula:

$$OP - 0.7RES \geq OTH \tag{1}$$

Where:

$$OP = |ITL + ITR| \tag{2}$$

$$RES = |ITL| + |ITR| \tag{3}$$

If we assume internal three phase faults, zero and negative sequence currents are zero, so that $IT = -C1I1$; $\angle ITL = \angle ITR$; $C1 = 0.1$.

A 20% margin is recommended, i.e.

$$OP = |ITL + ITR| = |(1484.3 + 2022.2) / 80| * 0.1 = 4.38 \text{ A}$$

$$RES = |ITL| + |ITR| = 4.38 \text{ A}$$

$$0.8(OP - 0.7RES) \geq OTH \Rightarrow OTH \leq 1.049 \text{ A}$$

Select $OTH = 1 \text{ A}$.

For the single end infeed condition for operating threshold OTH we should re-compute as: $OTH \leq 0.8 * ITL * 0.3$; ($ITR = 0$).

Sequence coefficients (Co;C1;C2):

REL 356 uses sequence filter to obtain positive, negative and zero sequence currents. These currents are then combined into one quantity as:

$$IT = -C1I1 + C2I2 + CoIo \tag{4}$$

Where $I1$, $I2$ and Io are positive, negative and zero sequence A phase currents. The sequence filter setting $C1;C2;Co$ must be the same at the two line ends.

As may be seen from Table 1, minimum fault current for internal phase to ground fault is greater than 67% of three phase fault current at both line ends. For this case sequence coefficients are:

$$C1 = 0.1$$

$$C2 = 0.7$$

$$Co = 0.0$$

Unequal CT ratio at both line ends:

Suppose that we have line CT's in substation A with ratio 200/5 and CT's in the substation B were unchanged 400/5. The OTH setting must be set the same at both line ends, i.e. $OTH = 1A$. In order to have operating current approximately zero for balanced load and three phase external fault currents, some modification must be done for coefficients $Co;C1;C2$. These coefficients should be modified at line end with **higher** CT ratio. In our case all coefficient must be multiplied with 2 (400/200) at the line end with **higher** CT ratio, i.e.

$$C1 = 0.2$$

$$C2 = 1.4$$

$$Co = 0.0$$

TEST RESULTS:

LINE END	C0 (set value)	C1 (set value)	C2 (set value)	Phase A current (injected)	Phase B current (injected)	Phase C current (injected)	IT (measured) phase A	IT (measured) phase B	IT (measured) phase C
A	0.0	0.1	0.7	5 A	5 A	5 A	0.96 A	1.24 A	1.24 A
A	0.0	0.1	0.7	5 A	5 A	5 A	0.96 A	1.26 A	1.26 A
A	0.0	0.2	1.4	5 A	5 A	5 A	1.99 A	2.43 A	2.45 A
A	0.0	0.2	1.4	5 A	5 A	5 A	1.95 A	2.40 A	2.46 A
B	0.0	0.1	0.7	2.5 A	2.5 A	2.5 A	0.48 A	0.64 A	0.61 A
B	0.0	0.2	1.4	2.5 A	2.5 A	2.5 A	0.96 A	1.24 A	1.23 A
B	0.0	0.2	1.4	2.5 A	2.5 A	2.5 A	0.98 A	1.22 A	1.24 A
B	0.0	0.1	0.7	2.5 A	2.5 A	2.5 A	0.47 A	0.61 A	0.62 A

In order to simulate different CT ratio at both line ends i.e 200/5 and 400/5, it was supposed that line nominal current is 200 A primary.

**Appendix
Short Circuit Calculation**

Equivalent positive and negative sequence circuits:

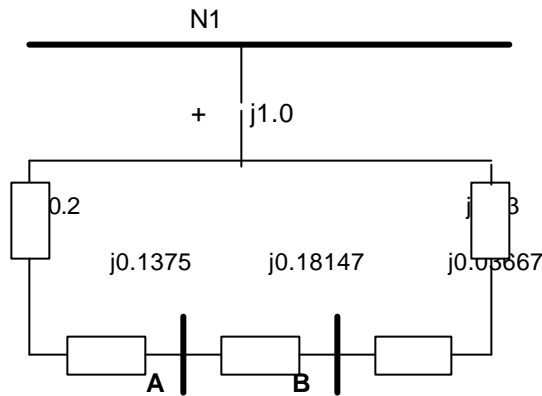

Equivalent Thevenen impedance looked from point A is (after simple circuit reduction of series/parallel connected impedances):

$$\begin{aligned}
 Z_{\Sigma} &= 0.143 \text{ pu} \\
 I_{pu} &= E / Z_{\Sigma} = 1 / 0.143 = 6.99 \text{ pu} \\
 I_b &= S_b / \sqrt{3} U_b = 100\,000 / (\sqrt{3} * 115) = 502 \text{ A} \\
 I_{act} &= 6.99 * 502 = 3509 \text{ A}
 \end{aligned}$$

In the same way equivalent Thevenen impedance for fault at point B is:

$$\begin{aligned}
 Z_{\Sigma} &= 0.059 \text{ pu} \\
 I_{act} &= 16.95 * 502 = 8508 \text{ A}
 \end{aligned}$$

For the calculation we select minimum three phase current i.e. 3509 A. Current distribution coefficients are :

$$0.24814/0.58564=0.423 \text{ from left side (source A) and } 0.5763 \text{ from right side}$$

(source B).

Equivalent zero sequence circuit is:

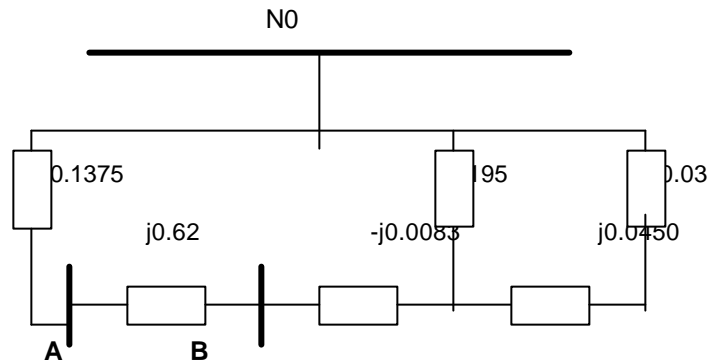

Equivalent Thevenen impedance looked from point A is (after simple circuit reduction of series/parallel connected impedances):

$$Z_{\Sigma 0} = 0.1141 \text{ pu}$$

$$I_{pu} = 3E / (Z_0 + Z_1 + Z_2) = 3/0.4 = 7.5 \text{ pu}$$

$$I_b = S_b / \sqrt{3} U_b = 100\,000 / (\sqrt{3} * 115) = 502 \text{ A}$$

$$I_{act} = 7.5 * 502 = 3765 \text{ A}$$

In the same way equivalent Thevenen impedance for fault at point B is:

$$Z_{\Sigma 0} = 0.0477 \text{ pu}$$

$$I_{act} = 8.99 * 502 = 4513 \text{ A}$$

For the calculation we select minimum phase ground current i.e. 3765 A.

Considering distribution factors for positive, negative sequence (0.423 for station A) and zero sequence (0.83 from station A), phase to ground fault contribution from station A is 2103.4 A and contribution from station B is 1661.6 A.

Contributed by:
Fahrudin Mekic
Revision 0, 2/01

ABB, Inc.
7036 Snowdrift Road
Allentown, PA 18106
800-634-6005 Fax 610-395-1055
Email: powerful.ideas@us.abb.com
Web: www.abb.com/substationautomation