

Substation Automation and Protection Division

Quick Start Guide For The DNP Orion To ABB REL 356 Relays Using Modbus

This Quick Start Guide shall enable the user to attach a REL 356 protective relay to the ORION unit communicating over a 485 physical cable connection.

Required equipment:

- A. ORION UNIT (TABLE TOP or RACK MOUNT)
- B. ONE ABB REL 356 PROTECTIVE RELAY
- C. IBM Compatible PC with Windows 95, or 98 installed.
- D. ONE PONI –M Modbus PONI Card.
- E. ONE COMSET UTILITY DISK TO SET THE MODBUS PONI CARD ADDRESS
- F. ONE RS 232 to RS 485 PHYSICAL INTERFACE CONVERTER.
- G. ONE CABLE ASSEMBLY KIT WHICH CONTAINS:
 - a. One RS 485 Cable.
 - b. One Troubleshooting Diskette.

1. It is imperative to realize that the ORION is available in two formats, a 19” rack mount version and a Table Top version. Please refer to the appropriate diagrams when using this guide. Apply power to the universal power supply according to the markings on the unit as shown in Figure 1 or Figure 1A as depicted in illustration 1. The unit accepts voltages from 55 to 200 V a.c. or 20 to 280 V d.c.

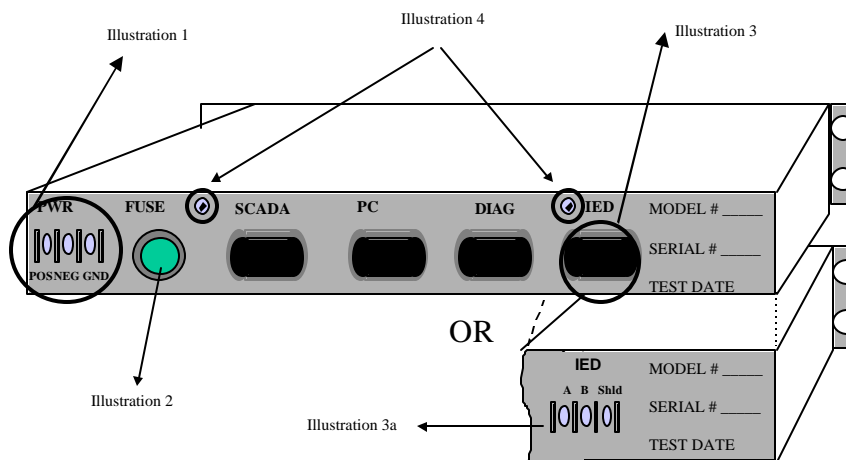

ORION Rack Mount Connector Location

Figure 1 – Orion Rack Mount Connector Diagram

ORION TABLETOP CONNECTOR LOCATION

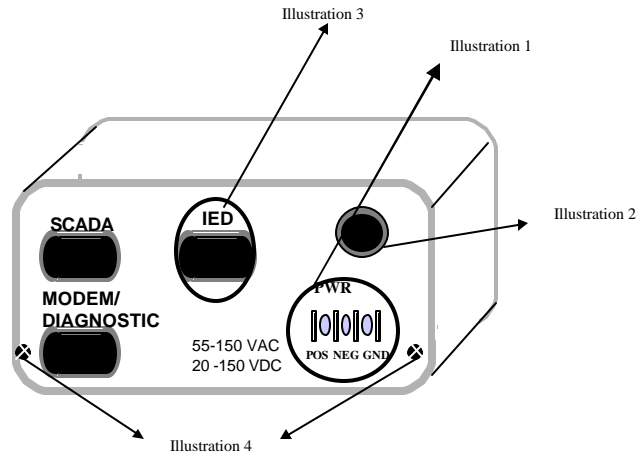

Figure 1A – Orion Table Top Connector Location

2. Connect the SCADA host to the ORION SCADA MASTER RS 232 port with a 9 pin D shell connector. The cable end should mate with the ORION's male connector. The unit is a DTE pinout and a custom cable may have to be developed for your application since SCADA Host RS 232 connections, handshaking requirements vary per each manufacturer. The ORION SCADA MASTER RS 232 port connection is shown in Figure 2 illustration 1 for a rack mount unit or Figure 2A for a table top unit.

ABB Orion Rack Mount Connectivity Diagram

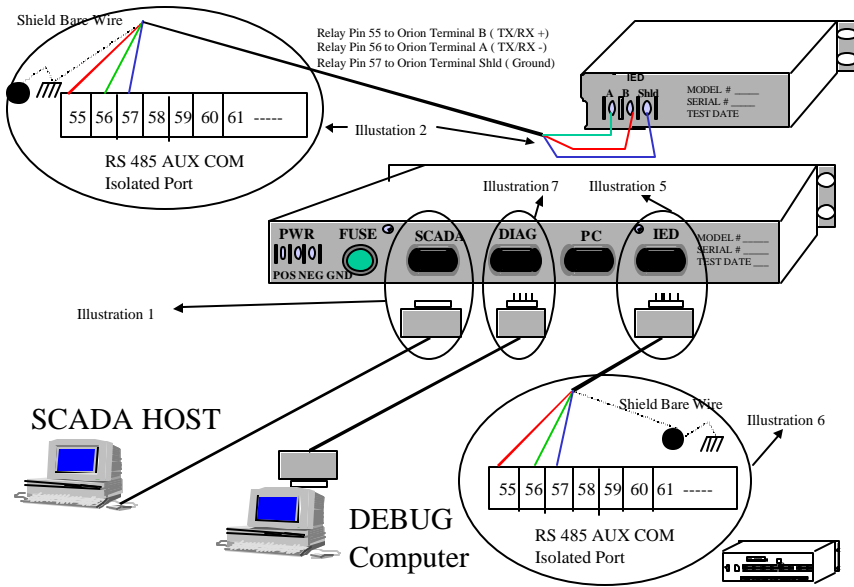

Figure 2 – Orion Cable Connection Diagram

TABLE TOP CABLE LOCATION

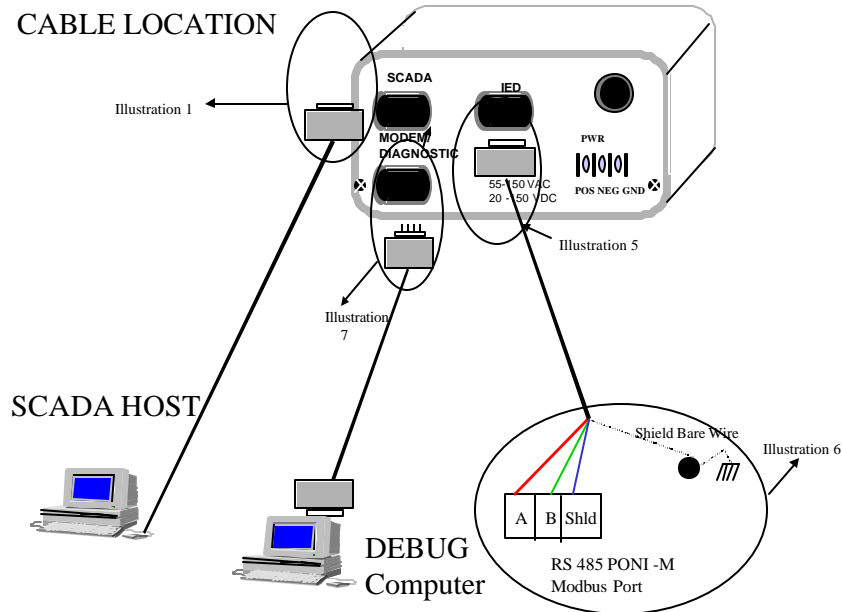
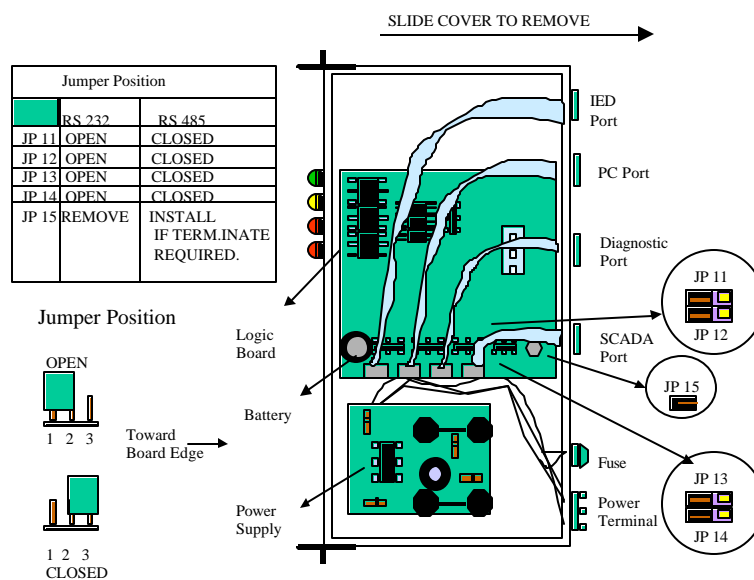

Figure 2A – Orion Table Top Cable Connection Diagram

- Configure the IED port in RS 485 mode. The IED port is shown in Figure 1 or 1a depending upon the unit, illustrations 3 and 3a. Some rack mount units and all Table Top ORION units have a DB 9 port for RS 485 device connection whereas some Rack Mount ORION units may have three screw terminals for an IED port physical connection. **FOR AN ORION RACK MOUNT UNIT:** Remove the two screws from the rear of the unit as shown in Figure 1, illustration 4. Slide the metal cover away from the unit to expose the electronic boards contained within the enclosure. As shown in Figure 3, five jumpers, JP 11, JP 12, JP 13, JP 14, and JP15 shall be placed in the appropriate positions for RS 485 communication as indicated in Figure 3 (JP 11 through 14 in the closed position and JP 15 closed to insert resistor termination). Breakouts of each of the jumper locations are shown in Illustration 1 and Illustration 2. The position of the jumpers in the “open” or “closed” positions are highlighted. **FOR AN ORION TABLE TOP UNIT:** For the Table Top Unit the instructions for dis-assembly are much more involved. Follow the dis-assembly instructions as presented in Figure 3A. Install the jumpers JP 11, JP 12, JP 13, JP 14, and JP15 as defined in the Table presented in Figure 3A.
- Reassemble the unit following the reverse order of the tasks as presented in step three of this Quick



ORION Rack Mount Jumper Locations

Start Guide.

Figure 3 - Orion Rack Mount Jumper Locations.

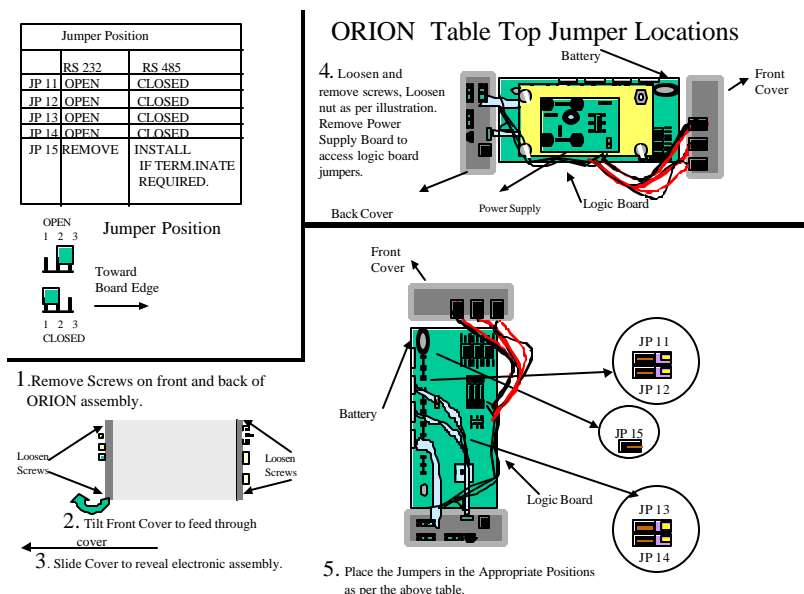

Figure 3A - Orion Table Top Jumper Locations

5. Within the optional cable assembly pack is a 50 foot length of cable with a 9 pin D shell connector on one end and three bare conductors (red, green, and blue), with a shield on the other. If the IED port on the supplied unit is a 9 pin DB9, connect the male D shell connector to the IED port which is shown in Figure 1 illustration 3 as well as Figure 2 Illustrations 5 and 6. Tighten the cable retaining screws to firmly attach the cable to the unit. If the physical connection not a DB 9 connection, interconnect the devices as shown in Figure 2 Illustration 2. Refer to the OPTIONAL INFORMATION section at the end of this document for specific cable pinout designations.
6. The REL 356 Modbus PONI [PONI-M] card only allows for RS 485 communication through the AUX COM PORT. Its location is shown in Figure 2 (illustration 6 and Illustration 5 or Illustration 2 depending upon the physical connection type) or Figure 2A (illustration 5). Connect the conductors as follows. RED (TX/RX +) to terminal A, GREEN (TX/RX -) to terminal B, and common Blue (Common) to the shield connection of the Phoenix Green Connector on the Modbus PONI-M Card. The shield (in this quick start case only), shall be connected to the frame ground connector as shown. The REL 356 Modbus PONI-M card does not have an internal termination resistor jumper (as the ORION unit does). Place a 120 ohm resistor across the A and B connections on the Phoenix connector as shown in the wiring example in the OPTIONAL INFORMATION SECTION contained in this document.
7. Install the COMSET program and configure the Modbus PONI-M card port parameters to 9600 Baud, Modbus ASCII Emulation, No Parity, 2 Stop Bits. Type "comset" (without quotation marks) to initiate program execution. Attach the PONI -M card to a computer through an RS 232 to RS 485 converter as per figures 7 and 8. Start COMSET and configure using the parameters specified per the following procedure.

The COMSET program will automatically search for the active port and the parameters currently configured in the unit. The COMSET program has the ability to UPLOAD (transfer the settings from the PONI card to the PC) or DOWNLOAD (transfer the settings from the PC to the PONI Card). The user must select the SETUP menu item. The screen presented to the user is shown in Figure 4. Menu settings for the PC port to communicate with the MODBUS PONI [PONI-M] are shown in Figure 5. Menu settings for configuration of the MODBUS PONI card port settings are shown in Figure 6.

Quick Start Guide For The DNP Orion To ABB REL 356 Relays Using Modbus

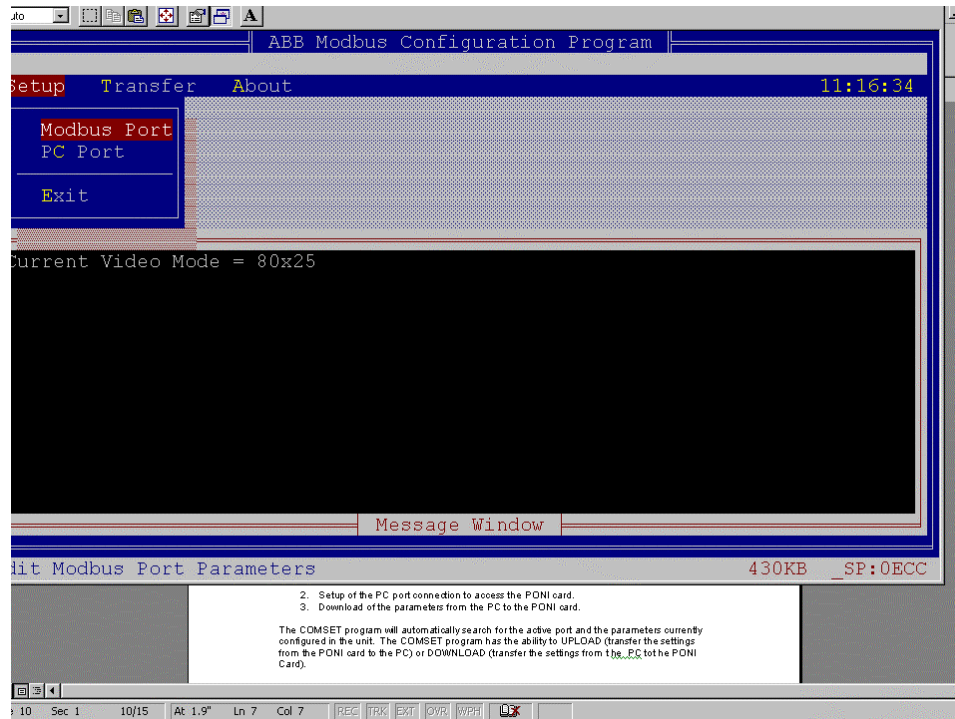

Figure 4 - PC Port Menu Selection VIA Comset

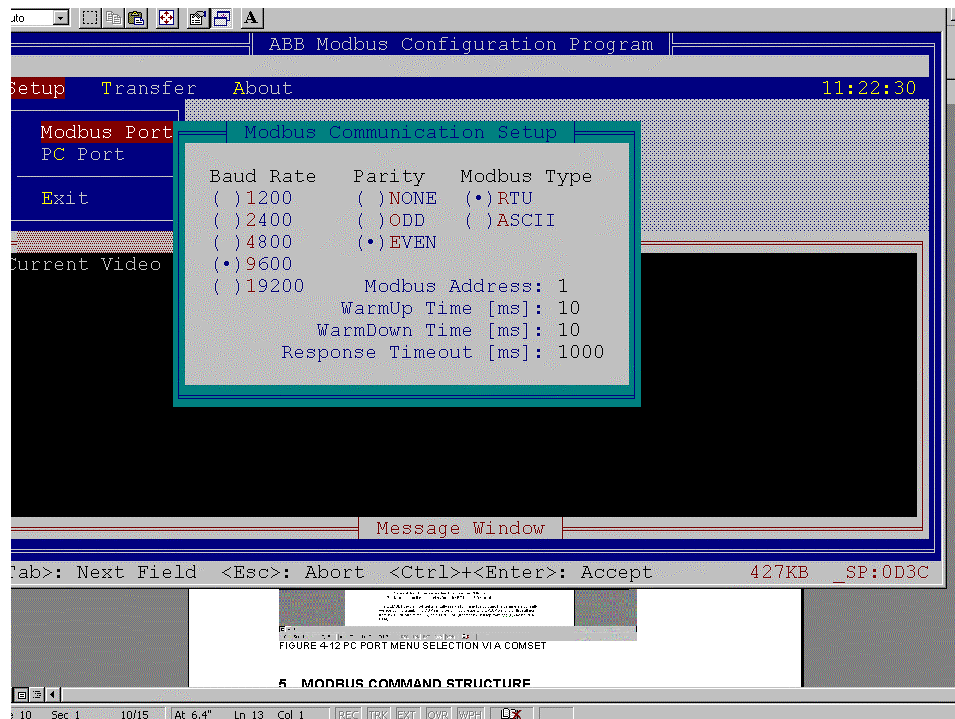

Figure 5 – MODBUS PONI –M Configuration Menu Presentation

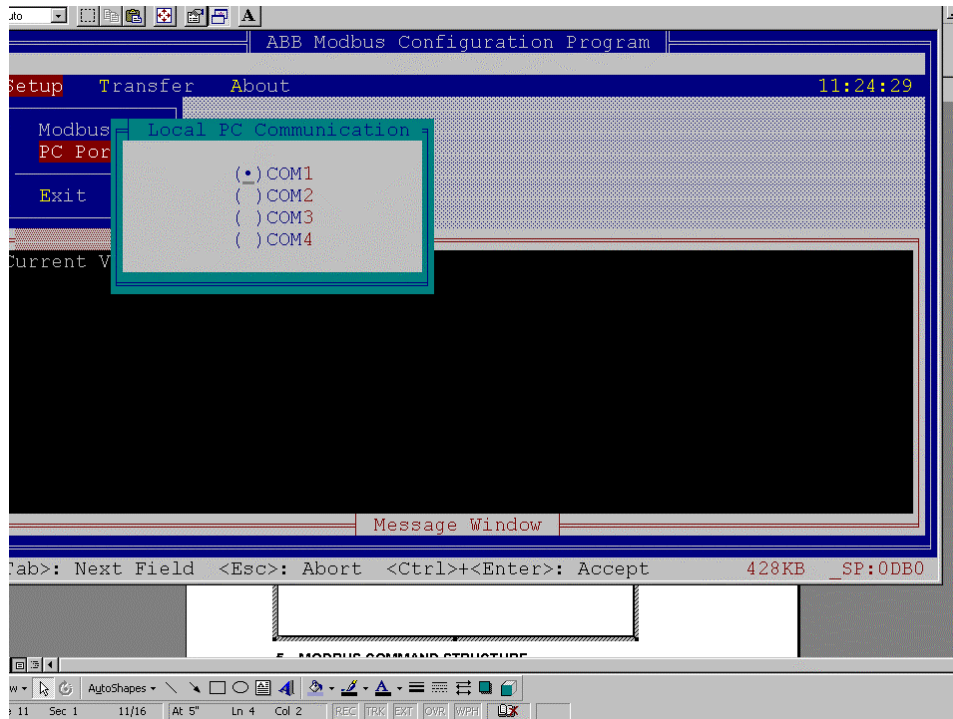

Figure 6 - MODBUS PONI –M PC PORT Configuration Screen Presentation

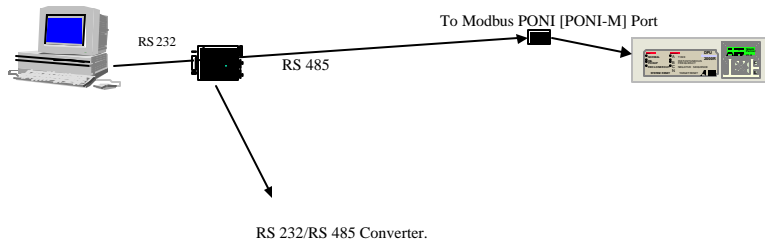

Figure 7 – Point To Point Configuration Architecture

8. The ORION unit allows the operator to configure the unit by connecting an IBM compatible PC RS 232 port via a cable. Attach the RS 232 cable to the ORION DIAGNOSTIC PORT as shown in Figure 2, illustration 7 or Figure 2A illustration 7 depending upon unit selected.
9. SOFTWARE CONFIGURATION: Supplied with the unit is a diskette with a file "CTL2MOD.exe". This file configures the point mapping for the Conitel C300 to Modbus conversion. The Conitel information varies from the format of Modbus and therefore the mapping of the two dissimilar protocol's points must occur. Place the file into the a directory within the personal computer. TYPE "CTL2MOD" and depress the "ENTER KEY".
10. Use the arrow keys to scroll to the "Setup" Menu. Select the submenu titled PC -Prot Conv. The following menu shall appear. Select the parameters as shown. The Port selection, however should be modified to match your computer systems hardware configuration. After selection of all parameters, simultaneously depress the "CONTROL and ENTER" key on the configuration terminal's keyboard.

```

NovelTech Conitel-Modbus Configuration Program
PRINTER: READY                               FILE NAME: TEST.CIL
File Setup Memory Map Transfer About         10:37:06
-----|-----|-----|-----|-----|-----|
| Local PC Communication Setup |
|
| Port      Baud Rate  Parity  Data Bits  Stop Bits
| (|)COM1   ( )300    (|)NONE ( )6       (|)1
| ( )COM2   ( )600    ( )ODD  ( )7       ( )2
|           ( )1200  ( )EVEN (|)8
| Current V ( )2400
|           ( )4800
|           (|)9600
|           ( )19200
|
|-----|-----|
| Message Window |
|-----|-----|
<Tab>: Next Field <Esc>: Abort <Ctrl>+<Enter>: Accept
    
```

Figure 8 – Local PC Communication Setup Screen For The Orion DIAG Port.

11. With the "SETUP" parameter highlighted, select the ProtConv Modbus Setup submenu selection, until the following screen is displayed. The parameters listed in Figure 5 match those in the protective device configuration (Step 7). After selection of all parameters, simultaneously depress the "CONTROL and ENTER" key on the configuration terminal's keyboard.

```

+-----+ NovaTech Conitel-Modbus Configuration Program +-----+
| PRINTER: READY                                     FILE NAME:   TEST.CIL |
| File  Setup  Memory Map  Transfer  About          10:37:10 |
+-----+-----+-----+-----+-----+-----+
| PC-P+-----+ Modbus Communication Setup +-----+ |
| Prot|                                     | |
| Prot| Baud Rate  Parity  Data Bits  Stop Bits | |
|-----+-----+-----+-----+-----+-----+ |
| ( )300  ( )NONE ( )6      ( )1 | |
| ( )600  ( )ODD  ( )7      ( )2 | |
| ( )1200 ( )EVEN ( )8      | |
|-----+-----+-----+-----+-----+-----+ |
| Current Video |                                     | |
| ( )2400 |                                     | |
| ( )4800 |                                     | |
| ( )9600 |                                     | |
| ( )19200|                                     | |
|                                     | WarmUp Time [ms]: 10 |
|                                     | WarmDown Time [ms]: 10 |
|                                     | Response Timeout [ms]: 1000 |
|                                     | Intercommand Delay [ms]: 100 |
|-----+-----+-----+-----+-----+-----+ |
+-----+-----+-----+-----+-----+-----+
| Message Window |-----+-----+
|
|<Tab>: Next Field  <Esc>: Abort  <Ctrl>+<Enter>: Accept

```

Figure 9 - Orion MODBUS IED Port Configuration Screen.

- With the "SETUP" parameter highlighted, select the PROTCNV CONITEL Setup submenu selection, until the following screen is displayed. The parameters listed in Figure 6 match those in the CONITEL Host. After selection of all parameters, simultaneously depress the "CONTROL and ENTER" key on the configuration terminal's keyboard.

```

+-----+ NovaTech Conitel-Modbus Configuration Program +-----+
| PRINTER: READY                                     FILE NAME:   TEST.CIL |
| File  Setup  Memory Map  Transfer  About          10:37:15 |
+-----+-----+-----+-----+-----+-----+
| PC-P+ Edit Conitel Comm Parameters +-----+ |
| Pro|                                     | |
| Pro|                                     | |
|-----+-----+-----+-----+-----+-----+ |
| Current Video |                                     | |
|                                     | Station Address: 1 |
|                                     | Baud Rate: 1200 |
|                                     | Warmup Time [ms]: 40 |
|                                     | Warmdown Time [ms]: 0 |
|                                     | Timeout [ms]: 800 |
|                                     | PLC with Reset Coil: 1 |
|                                     | Reset Coil: 9999 |
|                                     | Check Back Before Operate Time [ms]: 1000 |
|-----+-----+-----+-----+-----+-----+ |
+-----+-----+-----+-----+-----+-----+
| Message Window |-----+-----+
|
|<Esc>: Abort  <Ctrl>+<Enter>: Accept New Parameters

```

Figure 10 – CONITEL Configuration Screen For The Orion SCADA Port

- The configuration of each of the hardware communication ports is now completed. The next steps illustrate the configuration of a single point map from the CONITEL unit to the MODBUS nodes attached. Within the Configuration Program, select the MEMORY MAP item in the configuration selection, a display with several choices is displayed. Select the ADD INPUTS selection.

```
+-----+ NovaTech Conitel-Modbus Configuration Program +-----+
| PRINTER: READY                                     FILE NAME: TEST.CIL |
| File  Setup  Memory Map  Transfer  About          10:37:30 |
+-----+-----+-----+-----+-----+-----+
|                                     | Add Inputs |
| Standard +-+ Select Point Type +---+ |
| Special +-+ |                                     |
+-----+-----+-----+-----+-----+-----+
|                                     | 1: Conitel Input - AI |
|                                     | 2: Conitel Input - ACCUM |
|                                     | 3: Conitel Input - POLL |
|                                     | 4: Conitel Input - MCD-NO |
| Current Video Mode = 80x25 | 5: Conitel Input - MCD-NC |
|                                     | 6: Conitel Input - STATUS |
|                                     | 7: Conitel Input - FLOAT |
+-----+-----+-----+-----+-----+-----+
|                                     | Message Window |
+-----+-----+-----+-----+-----+-----+
Use Cursor Keys to Move Select Bar then <Enter>. <Esc>: Quit
```

Figure 11 – Add Inputs Point Configuration Screen

- For this "QUICK START" example, Conitel Input AI shall be configured for a DPU 2000R device attached to the IED port. If the DPU 2000R Modbus document is reviewed, Phase A, B, and C, load currents and their respective load angles are located at eight consecutive registers beginning at 40257 through 40264 and they shall be remapped to the Conitel blocks 1b through 5a. The Conitel SCAN INPUT command shall access these blocks. After selection of all parameters, simultaneously depress the "CONTROL and ENTER" key on the configuration terminal's keyboard.

```

+-----+ NovaTech Conitel-Modbus Configuration Program +-----+
| PRINTER: READY                                     FILE NAME: TEST.CIL |
| File  Setup  Memory Map  Transfer  About          10:38:33 |
+-----+-----+ Standard Modbus-Conitel Input +-----+
|
| Conitel Data Type: AI
| Point Description: Analog Input #1
| Conitel Group: 1
| Conitel Point Start: 1
| Number of Conitel Points: 8
| Conitel Section Start: 1b
| Conitel Section End: 5a
|
| MODICON PLC Address: 2
| Start Modbus Register: 40257
| Number of Registers: 8
|   Zero Value:      0.0000
|   Span Value:     400.00
|
+-----+-----+ Message Window +-----+
|
|<Tab>: Next Field  <Esc>: Abort  <Ctrl>+<Enter>: Accept

```

Figure 8 – Analog Input Mapping Screen

- The configuration files must now be downloaded to the ORION unit. Select the TRANSFER menu and then select the Download Option. The following screen should be displayed. When the parameters are accepted by the ORION, an indication shall be shown on the screen. Additionally, the amber CONFIG LED at the front panel of the unit shall not flash. A constant illumination shall

ORION Troubleshooting Guide

This section illustrates some common solutions to problems encountered when configuring an ORION unit in the configuration described in this Quick Start Guide. Reference Table 1 below.

Table 1 – Troubleshooting Guide

ISSUE	RESOLUTION
1. The ORION unit LED's do not illuminate.	<ul style="list-style-type: none"> A. Verify the power wiring to the power connector (Figure 1 Illustration 1). B. Check for a blown fuse (Figure 1 Illustration 2).
2. The ORION Green RUN LED does not flash at a 1 second interval.	<ul style="list-style-type: none"> A. Unit is defective. Contact reseller for a return authorization number
3. Communication does not occur between the Diagnostic port and the emulator terminal on the ORION. (Unit will not attach for configuration of the unit [Steps 15 through 21]).	<ul style="list-style-type: none"> A. Verify the RS 232 Cable Connections from the PC to ORION Diag port. (Figure 2 Illustration 7). B. Verify the PC to Prot Conv settings accessible through the setup menu of the CON2MOD setup utility. (Step 10 Figure 4). C. Does the PC com port match the com port settings in the PC to Prot Conv setting menu. (Step 10 Figure 4).
4. The ORION Amber CONFIG LED flashes .	<ul style="list-style-type: none"> A. The ORION has not been configured. Download the saved configuration file from the configuration terminal. (Step 15 Figure 9)
5. Communication does not occur between the relay and the ORION connection via the IED port on the ORION.	<ul style="list-style-type: none"> A. Verify the Supplied IED RS 485 connections and cable connections as shown in Figure 2. B. Verify the port parameters in the attached relay as described in Step 7. C. Verify the ORION configuration settings as described in Step 11 Figure 5. D. Have the configuration settings been downloaded to the ORION as described in Step 15 Figure 9. E. Modify the Warm –Up and Warm Down delays in the Modbus IED port parameterization screen to be 10 mS less than is presently configured. Download the new configuration to the ORION Unit. (Step 11 Figure 5 and Step 15 Figure 9).
6. The Red TX or RX LED's do not illuminate on the ORION Unit when the DNP 3.0 Host communicates to the ORION Unit.	<ul style="list-style-type: none"> A. Verify the SCADA Port Cabling per the Host manufacturer's specification. B. Verify the Conitel Port Configuration through the setup menu of the CON2MOD setup utility. (Step 12 Figure 6). C. Port Timeout has occurred; decrease the Warm Up and Warm-down timeout values by 10 mS until issue resolved.

<p>7. Communications Strings are not visible when the RUN MMI and submenu 2 Toggle Modbus Port Display) selection are visible (steps 16 through 21)</p>	<ul style="list-style-type: none"> A. Verify the Supplied IED RS 485 connections and cable connections as shown in Figure 2. B. B Verify the port parameters in the attached relay as described in Step 7. C. Verify the ORION configuration settings as described in Step 11 Figure 5. D. Have the configuration settings been downloaded to the ORION as described in Step 15 Figure 9. E. A timeout has occurred. Modify the Warm –Up and Warm Down delays in the Modbus IED port parameterization screen to be 10 mS less than is presently configured. Download the new configuration to the ORION Unit. (Step 11 Figure 5 and Step 15 Figure 9).
<p>8. Excessive CRC errors result when viewing the communication strings via the Configuration diagnostic screens.</p>	<ul style="list-style-type: none"> A. Determine that the jumper settings have been set for RS 485 (Step 3 Figure 2) operation. B. .Verify that the termination resistor and the pullup resistors are configured in the IED protective relay (Jumpers J6 [termination], J8 [Pullup], and J7 [Pulldown]) (Step 6).
<p>9. Communications Strings are not visible when the RUN MMI and submenu 1 Toggle DNP 3.0 Port Display) selection are visible (steps 16 through 21)</p>	<ul style="list-style-type: none"> A. Check the SCADA Port Cabling per the Host manufacturer’s specification. B. Verify the (SCADA) Conitel Port Configuration through the setup menu of the CON2MOD setup utility. (Step 12 Figure 6). C. Conitel (SCADA) Port Timeout has occurred decrease the Warm Up and Warm-down timeout values by 10 mS until issue resolved. D. Verify the Supplied IED RS 485 connections and cable connections as shown in Figure 2 (Step 6). E. Verify the IED port parameters in the attached relay as described in Step 7. D. Verify the ORION IED configuration settings as described in Step 11 Figure 5. E. Have the configuration settings been downloaded to the ORION as described in Step 15 Figure 9. F. A timeout has occurred. Modify the IED’s Warm –Up and Warm Down delays in the Modbus IED port parameterization screen to be 10 mS less than is presently configured. Download the new configuration to the ORION Unit. (Step 11 Figure 5 and Step 15 Figure 9). G. If the communications between the IED

	<p>and ORION are RS 485, verify that the termination resistor has been installed (JP 15) in the ORION (Figure 3).</p> <p>H. If the communications between the IED and ORION are RS 485, verify that the termination resistor and the pullup resistors are configured in the “end” protective relay (Jumpers J6 [termination], J8 [Pullup], and J7 [Pulldown]) (Step 6).</p>
--	---

Optional Information

The RS 232 Cables and RS 485 Cable diagrams are included below for reference:

ORION RS 232 C CABLE

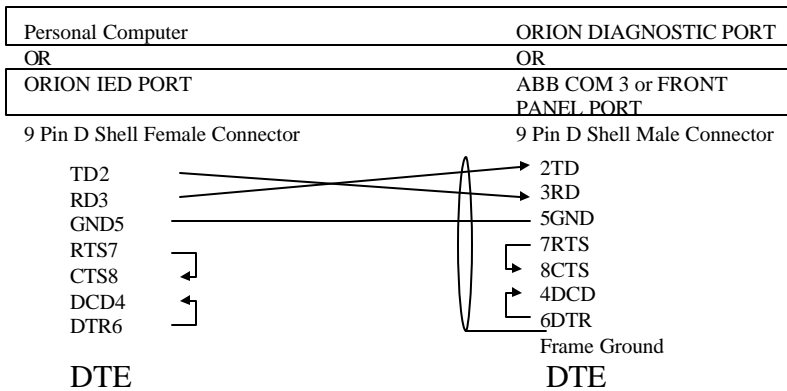

Figure 14 - ORION RS 232 Cable For Communications From The DIAG Port To Personal Computer.

ORION RS 485 Connection DIAGRAM

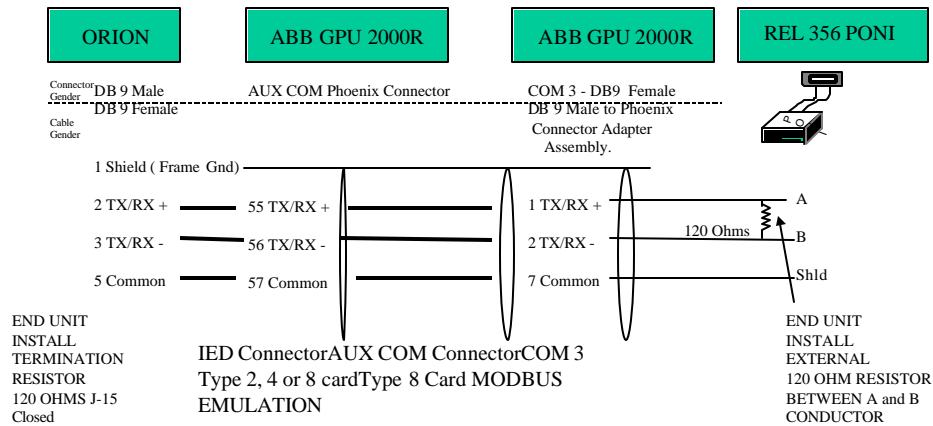

Figure 15

Contributed by:
John Popiak
Revision 1, 2/00

ABB, Inc.
7036 Snowdrift Road
Allentown, PA 18106
800-634-6005 Fax 610-395-1055
Email: powerful.ideas@us.abb.com
Web: www.abb.com/substationautomation