

IRB 260 Industrial Robot

MAIN APPLICATIONS

Packing



Compact Industrial Packing Robot

The IRB 260 is based on IRB 2400, the world's most popular industrial robot with a total of 14,000 installations. Designed for easy integration into packaging lines, the new machine has the ability to work close to base in order to minimize floor space. Low on weight and height, the IRB 260 fits easily into compact production cells. Speed, moreover, has been optimized for an 800x800x800 mm working envelope, making the

new robot ideal for packing applications. Running on 4-axes, it's not only dedicated to packing applications, but also ensures high throughput and flexible packing concepts. Like all ABB robots, IRB 260 can be combined with PickMaster – ABB's vision guided packaging software – and our new IRC5 controller.

IRB 260

Specification

Handling capacity	30 kg
Reach	1.56 m
Load offset	300 mm
Number of axes	4
Integrated signal supply	23 poles, 50V DC
	10 poles, 250V AC
Integrated air supply	1/3 inch hose, max 8 bar

Performance

Position repeatability	0.1 mm
------------------------	--------

Axis movements Working range IRB 260

Axis 1 Rotation	+180° to -180°
Axis 2 Arm	+85° to -28°
Axis 3 Arm	+119° to -17°
Axis 6 Turn	+300° to -300°

Max Velocity

Axis 1	153°/s
Axis 2	175°/s
Axis 3	153°/s
Axis 6	342°/s

Physical

Total height	1493 mm
Manipulator base	723x600 mm
Weight	340 kg

Environment

Ambient temperature	5°C -45°C
Relative humidity	Max 95%
Degree of protection	IP 67
Noise level	Max 70 dB(A)
Emission	EMC/EMI-shielded

Data and dimensions may be changed without notice

Working Range

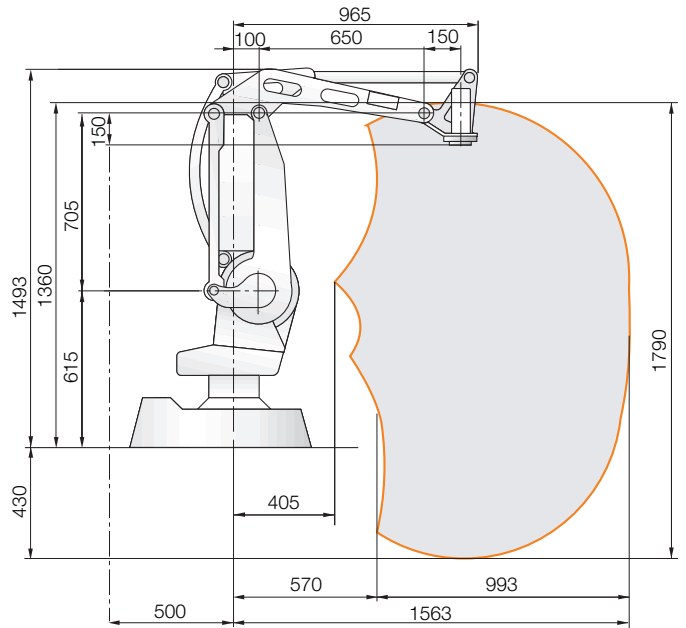

© Copyright ABB Robotics. PR10285EN_C September 2009.

Pack Cycle

125/500/600 mm	35-40 cycles at 20 kg
90/400/90 mm	50-60 cycles at 10 kg

