

# IRB 660 Industrial Robot

## MAIN APPLICATIONS

Material handling  
Palletizing



### Pushing the working envelope

The IRB 660 is a dedicated palletizer that blends speed, reach and payload like no other robot on the market. This is an exceptionally fast 4-axis machine that combines a 3.15 meter reach with a 250 kg payload, making it ideal for palletizing bags, boxes, crates, bottles and more.

The IRB 660 is considerably faster than its predecessor. Its optimized motor power and motion performance ensure significantly shorter cycle times than competing products. The new palletizer comes in a high-speed version capable of handling 180 kg payloads at full speed, and as a 250 kg version for high throughput.

The robot's impressive reach means it can service up to four in-feed conveyors, two pallet stacks, one slip-sheet stack and four palletizing out-feeding lines. In fact, the IRB 660 has the versatility, reach and handling capacity to meet the demands of just about any palletizing applications.

The IRB 660 is easy to come to grips with. ABB's multi-functional IRC 5 controller and comprehensive packaging line software, PickMaster, house all the key functions for quick, easy programming and intuitive operation on the shop floor. Furthermore, the robot's rugged design and IP 67 tightness make for steady performance in even the toughest environments. As well as ensuring those extra lengthy service intervals!

# IRB 660

## Specification

Robot versions	Handling capacity	Reach
<b>IRB</b>		
660-180/3.15	180 kg	3.15 m
660-250/3.15	250 kg	3.15 m
Number of axes:	4	
Protection class:	IP 67	
Mounting:	Floor mounted	

## Performance

Position repeatability	0.1 mm
Path repeatability	0.3 mm

## Axis movements

### Working range IRB 660

Axis 1 Rotation	+180° to -180° Option +220° to -220°
Axis 2 Arm	+85° to -42°
Axis 3 Arm	+120° to -20°
Axis 6 Turn	+300° to -300° Default +150 rev. to -150 rev. Max.

## Max velocity

Axis no.	IRB 660-180/3.15	IRB 660-250/3.15
1	130°/s	95°/s
2	130°/s	95°/s
3	130°/s	95°/s
6	300°/s	240°/s

## Electrical connections

Supply voltage	200-600 V, 50/60 Hz
Power consumption	ISO-Cube 2.7 kW Normal movements 3.2 kW

## Physical

Robot base	1136 x 850 mm
Weight	1650 kg

## Environment

### Ambient temperature for mechanical unit:

During operation:	+5°C (41°F) to +50°C (122°F)
During transportation and storage:	-25°C (-13°F) to 55°C (131°F)
For short periods	(Max. 24 h): +70°C (158°F)
Relative humidity	max 95%
Noise level	Max 73 dB (A)

Safety	Double circuits with supervision, emergency stops and safety functions, 3-positions enable device
--------	---------------------------------------------------------------------------------------------------

Emission	EMC/EMI-shielded
----------	------------------

Data and dimensions may be changed without notice

## Working range at wrist center & load diagram

IRB 660-180/3.15 and IRB 660-250/3.15

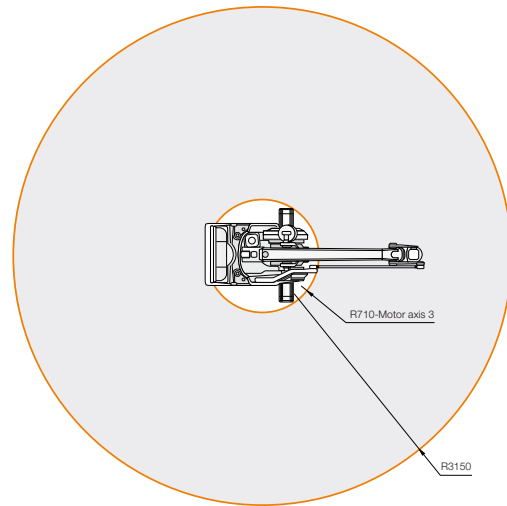
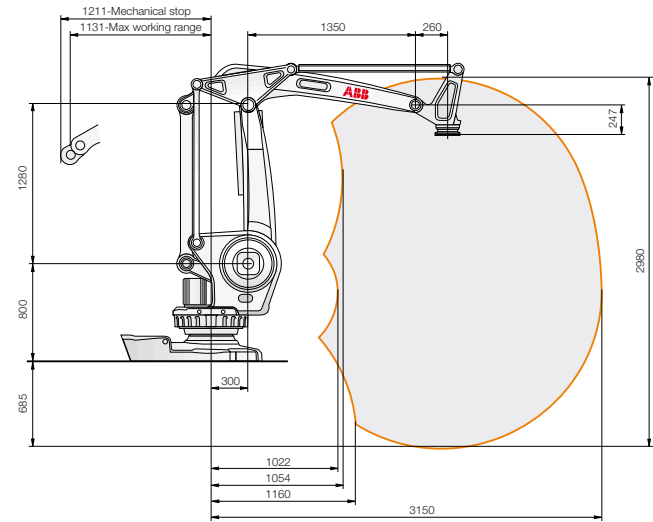

IRB 660 180/3.15

IRB 660 250/3.15

