

IRB 5400-13 Slim arm

Enhanced IRB 5400, CleanWall Rail System

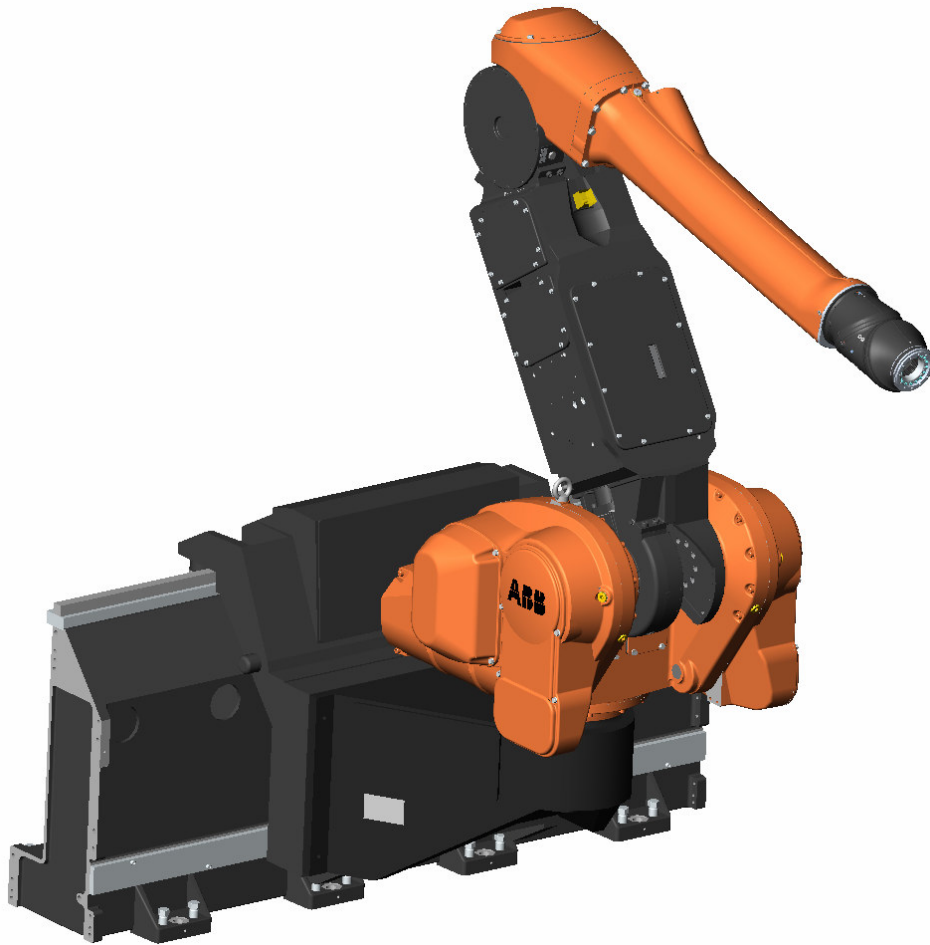

Increase Your Productivity

The IRB 5400-13 CleanWall rail system is an enhanced version of the efficient Paint Robot IRB 5400-03. The substantial performance of the IRB 5400 has increased even more with the IRB 5400-13.

CleanWall Rail Design

CleanWall construction provides for narrower spray booth widths, reduced air handling and lower energy requirements. These rails are suitable for both new facilities and for retrofits into existing spray booth systems. The CleanWall rail design allows for easy integration into the spray booth wall system.

Commonly supplied rail lengths range from 1.5 meters and extend to 12 meters or longer depending on application.

High Finish Quality

ABB's CleanWall rail system is available with ABB's exclusive Integrated Process System (IPS). IPS provides closed loop regulation, high speed and control for paint and air flow adjustments. This minimizes over-spray, secures uniform film build, maximizes finish quality and paint and solvent savings. The robot enables high quality while reducing cost and protecting the environment.

Easy Maintenance

The design of the vertical arm and its electronics is extremely easy to access and service. For fast and easy diagnostics LED signals can be read without removing any covers. There is less field connections and ample direct access to all components.

High Uptime

ABB's powerful software package CAP (Computer Aided Painting), including the ShopFloor Editor, allows easy programming and process tuning without interrupting production. Flexible communication interfaces make it easy to adapt to any painting requirement.

ABB's Cycle Time Saver

What makes this Paint Robot so superior and unique is the cycle time savings you as a user will gain. The extensive work-envelope combined with the unique, increased acceleration and the increased capacity both on the wrist and the counter-balance, has made this Paint Robot fully earn the name Cycle Time Saver.



IRB 5400-13 Slim arm

Enhanced IRB 5400, CleanWall Rail System

TECHNICAL DATA, IRB 5400-13

SPECIFICATIONS

Payload on wrist	25 kg
Handling cap. on vertical arm	50 kg
Handling cap. on horizontal arm (incl. wrist)	40 kg

Number of axes	7	
Axis movements:		
Axis:	Working range:	Max. speed:
Rotation	300°	137 %/s
Vertical arm	160°	137 %/s
Horizontal arm	150°	137 %/s
Inner wrist	Unlimited	440 %/s
Wrist bend	Unlimited	430 %/s
Outer wrist	920°	600 %/s

Pose accuracy	0.15 mm (Repeatability)
Path accuracy	+/- 3 mm

Rail system	Length 2m, 3m, 3.5m, 4m, 4.5m, ...
Pose accuracy	0.1 mm (Repeatability)
Velocity	1.5 m/s

ELECTRICAL CONNECTION

Supply voltage	3 ph., 200-600V, 50/60 Hz	
Power consumption	Stand by	< 300 W
	Production	1500 W
	Peak	5000 W

PHYSICAL

Dimensions:		
Robot main axes:		
Base	H 660, Ø 1130 mm	
Vertical arm	L 1200 mm	
Horizontal arm	L 1620 mm	
Robot Controller compact version	1250 x 800 x 580 mm	
Robot Controller extended version	2200 x 800 x 580 mm	
Weight:		
Standard robot excl. rail unit	790 kg	
Clean wall rail trolley	360 kg	
Clean wall rail element (2m)	680 kg	
Robot Controller compact version	max 320 kg	
Robot Controller extended version	max 350 kg	

ENVIRONMENT

Explosion protection		
North America	Class I, II, Division 1, Group C, D, G, 135°C	
Japan	II G T4	
Europe	II 2 G D (T65°C)	
EMC	Electro Magnetic Compatibility certificate	
Ambient temperature	Robot unit	5-45°C
	Robot Controller	5-52°C
Relative humidity	Non condensing max.	95%
Degree of protection	Protection standards	IEC 529
	Robot Unit	IP 67
	Wrist	IP 54
	Robot Controller	IP 54

USER INTERFACES

Operator panel	In cabinet or external
Programming unit	EExi protected. Portable, joystick and keyboard
	Display 16 lines x 40 characters
	Graphical 240 x 320 pixels
	Distributed intelligence
	Configurable on-screen menus
Safety	EMY stop, Enable device, General mode stop, Auto mode stop, Test mode stop, Cabin interlock.

MACHINE INTERFACES

Digital inputs/outputs	512/512
Analog inputs/outputs	16/12
Remote I/O	Interbus-S 64/64
	Allen Bradley RIO 128/128
	Profibus DP 128/128
	CC Link 128/128
Serial Channels	RS-232, RS-422, RS-485
Network	Ethernet NFS/FTP
	RAP Robot Application protocol
	Factory Ware interface
	High speed IPS link
	Real Time Data Logger
	DDE Server
Diskette drive	3.5" MS-DOS format

ROBOTWARE

OS	Robot Operating System, multitasking capability.
RAPID	Powerful application programming language.
Conveyor Tracking	Accurate synchronization of robotic motion, paint process regulation and the moving part for both linear and circular tracking in any direction.
IPS	Integrated Process System. Unique system for closed loop regulation and high speed control for paint and air flow adjustments. Based on open, flexible and adjustable architecture philosophy.

PC TOOLS

CAP	A Computer Aided Painting package containing ShopFloor Editor and RobView.
ShopFloor Editor	Off-Line editing of programs using 3D graphics for path and process tuning. Graphical programming and tuning of color change sequences.
RobView	Monitoring of robots and processes while in production. Easy design of user screens.
FlexUI	Custom built GUI application for system supervision and control.

WORK ENVELOPE

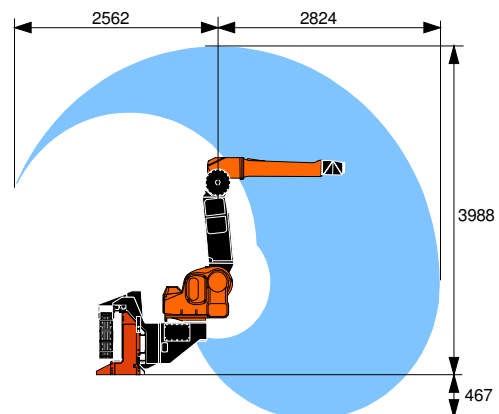

Data and dimensions may be changed without notice.