

IRB 360 FlexPicker™ Industrial Robot

Main Applications

Assembly
Material handling
Picking
Packing

Features

- High speed flexibility
- High capacity – up to 3 kg payload
- Hygienic design for wash down applications
- Superior tracking performance
- Integrated vision software

The IRB 360 FlexPicker™, is the SECOND GENERATION delta robot solution for precision pick and place applications. The robot has outstanding motion performance with shortest cycle times at high accuracy, and high payload. The PickMaster software is developed for ease of use and simplifies the robot integration.

The IRB 360 range comprises four variants. The compact variant, IRB 360-1/800, has a 800 mm diameter work area and its small footprint saves floor space and makes it easy to fit into compact packaging machines.

The IRB 360-1/1130 (standard version) has a working range optimized for the fastest picking applications. It now also comes in a high payload variant, IRB 360-3/1130 that can speed up the throughput by taking more products at a time or for simply handling heavier products. The standard version has been complemented with a version with longer arms targeted at the solar, food and beverage industries. It has a working range of 1600 mm which will enable the robot to reach over large conveyors and machines.



The IRB 360 is designed to work in meat and dairy applications. A stainless option with all metal parts in stainless is IP69K validated so that it can be washed down with industrial detergents and high pressure hot water. The robot does not only have great corrosion protection but is also designed with smooth and rinse-off surfaces and lubricant free joints

Setting up an application becomes easy using the PickMaster software. Based on experiences from 10 years, PickMaster has evolved into an invaluable help for integrators and users of IRB 360. It simplifies the vision configuration and offers the application tools needed for an efficient high speed picking application.

The reliable, market leading IRC5 controller is also an integral part of the FlexPicker™ robot solution. The IRC5 with TrueMove™ and QuickMove™ ensures the highest speed together with path following facilities - enabling the robot to track fast moving conveyor belts with high accuracy. The IRC5 is also available in a panel-mounted version that offers substantial space savings and easy integration into machines and production lines.

IRB 360

Specification

Robot versions	Handling capacity	Diameter	No. Axes
IRB 360-1/800	1 kg	800 mm	4
IRB 360-1/1130	1 kg	1130 mm	3/4
IRB 360-3/1130	3 kg	1130 mm	3/4
IRB 360-1/1600	1 kg	1600 mm	4
Supplementary load			
on upper arm	350 gram		
on lower arm	350 gram		
Integrated signal supply	12 poles 50V, 250mA		
Integrated vacuum supply	Max. 7 bar/max vacuum 0.75 bar		

Physical

Robot mounting	Inverted
Weight	120-145 kg

Performance

Position repeatability	0.1 mm
Angular repeatability	
Standard and stainless axis 4	0.4°
Wash-down axis 4	1.5°

Cycle time*

Typical cycle time for ø1130 mm standard variants

Cycle	Payload kg	Cycle time s
25/305/25	0.1	0.30
25/305/25	1	0.36
25/305/25	3	0.54
90/400/90	0.1	0.44
90/400/90	1	0.51
90/400/90	3	0.70

The cycle times in the table are measured under real conditions but cycle times may vary depending on the actual application (tool data, path radius, gripper activation etc.)

* Cycle times for IRB 360-1/800 and IRB 360-1/1600 differ in cycle time. Please use RobotStudio or real cycle time tests to verify actual cycle time.

Conveyor tracking**

Constant conveyor	Conveyor speed
speed [mm/s]	Repeatability [mm]
200	1.0
350-750	1.5
800-1400	5.0
Start/stop conveyor [mm/s]	Repeatability [mm]
500 (start/stop in 0.2 sec)	3.5

** The tracking performance is measured under real conditions with IRB 360-1/1130 and PickMaster. The figures may vary depending on the actual robot max. speed and acceleration performance in relation to what the application demands.

Electrical Connections

Supply voltage	200-600 V, 60 Hz
Rated power	
Transformer rating	7.2 kVA
Power consumption at max load	
Type of Movement	IRB 360/1
Typical pick - and - place cycle with 1 kg payload	0.477 kW

Environment

The base box and the arm system can be ordered independent of each other in standard, wash-down or stainless design. Depending on the combination the robot fulfils protection classes IP 56, IP 67 or IP 69K. If wash-down or stainless axis 4 is chosen, the robot can be washed down according to industrial standard.

Ambient temperature	IRB 360 manipulator	±0°C to +45°C
Relative humidity		Max. 95 %
Noise level		< 70 dB(A)
Safety		Double circuits with supervision, emergency stops and safety functions, 3-position enabling device
Emission		EMC/EMI shielded
Options axis 4		Stainless wash-down Clean Room, class 5/7 (certified by IPA) Stainless Clean Room class 5/7 (certified by IPA) Collision detection



Data and dimensions may be changed without notice

Working range and physical dimensions

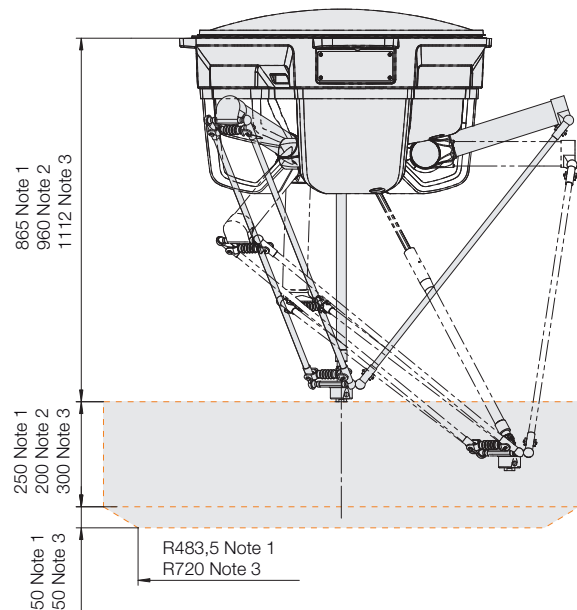

Note 1 : IRB 360-1/1130 and IRB 360-3/1130
Note 2 : IRB 360-1/800
Note 3 : IRB 360-1/1600