

QBank - Capacitor Bank



General

ABB's high voltage capacitor banks, type QBANK are built with single phase capacitor units mounted in hot-dip galvanized steel racks for up to twenty units in each rack. The units are connected in series and parallel to achieve the desired voltage and power rating.

The capacitor units may be mounted vertically, but are normally horizontally mounted to yield a very compact design. The banks are built by placing the racks on top of each other, with any necessary insulators in between, or side-by-side, depending on the space available at the installation site.

Only the basic principles are presented in this sheet. Indicated dimensions and data are non-binding.

Protection

There are principally two different types of capacitor protections, externally fused capacitors or capacitors with integrated self-protection. Externally fused capacitors are provided with a fuse for each unit. Capacitors with integrated self-protection can be provided with one fuse for each element within the unit, or be connected in parallel series strings. Each variant has its advantages and limitations and is used differently depending on the application.

Three-phase capacitor banks are normally star (Y)-connected. For most banks an unbalance protection is easily arranged by splitting the bank into a double star and connecting the two neutrals through a current transformer (Figure 1). Alternatively, large banks can be bridge (H)-connected. The capacitor units of each phase are then connected into two strings with a current transformer between the midpoints (Figure 2).

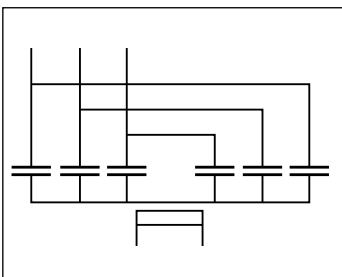

Fig. 1 Y-Y connection

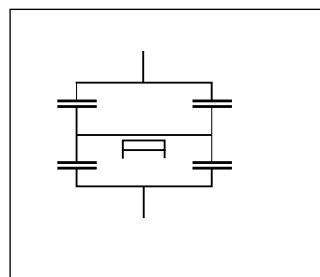

Fig. 2 Bridge connection

QBANK-C; Small banks (3-18 units)

In small capacitor banks, the units are normally mounted vertically in one rack. The highest rated voltage for QBANK-C is 24 kV and the maximum number of capacitor units is eighteen. Banks of three or six units are normally mounted in one rack and with no unbalance protection provided (Figure 3 and 4).

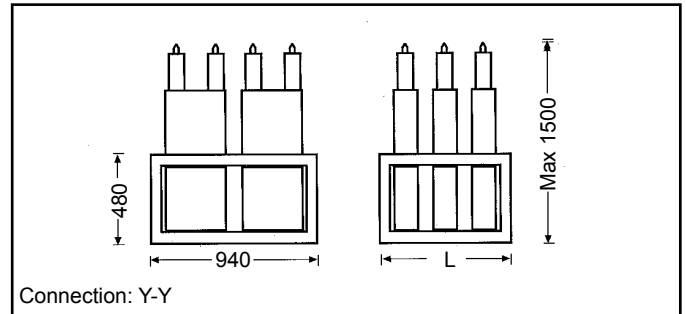

Fig. 3 Internal fuses

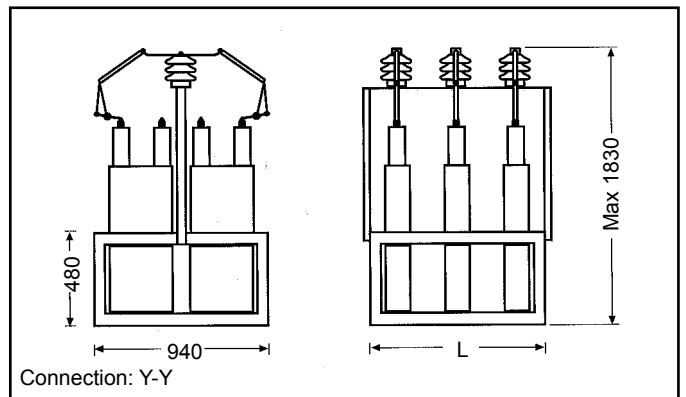

Fig. 4 External fuses

Dimensions and weights QBANK-C

Internal fuses

No. of units	-12kV L, mm	-24kV L, mm	Weight kgs, max
6	840	1260*)	700
9	1470	-	1050
12	1470	1890	1350
15	2100	-	1690
18	2100	-	1990

*) Connection: Y

External fuses

No. of units	L, mm	Weight kgs, max
6	1260	720
9	1890	1080
12	1890	1380
15	2100	1720
18	2100	2020

QBANK-B; Medium banks (9-30 units)

This type of capacitor banks can only be built with internally fused capacitor units. Horizontally mounted units are installed on one side of the rack only. The highest rated voltage for QBANK-B is 24 kV and the maximum number of capacitor units is thirty.

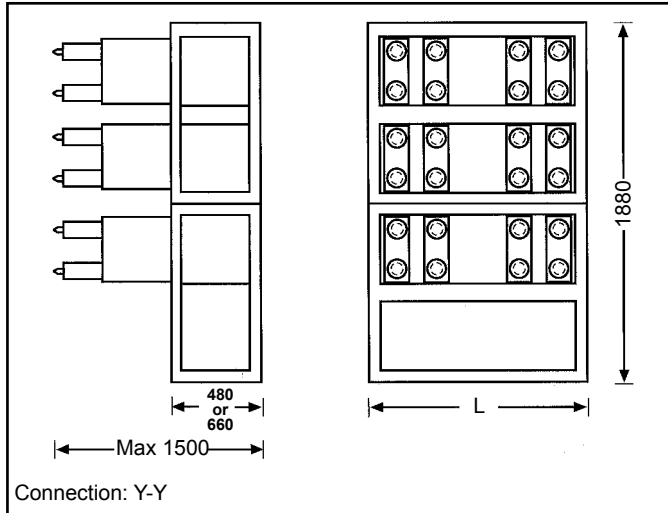

Fig. 5 QBANK-B, Internal fuses

Dimensions and weights QBANK-B

No. of units	-12kV L, mm	-24kV L, mm	Weight kgs, max
6	840	840	850
9	1050	-	1150
12	1260	1260	1450
15	1470	-	1850
18	1680	1680	2150
21	1890	-	2500
24	2100	2100	2800
27	2310	-	3150
30	2310	2310	3450

Dimensions and weights QBANK-A

No. of units	-12kV L, mm	-24kV L, mm	-36kV L, mm	-52kV L, mm	Weight kgs, max	Weight kgs*) max
12	840	840	840	-	2150	2250
18	840	1050	840	-	2800	2900
24	1050	1050	-	1050	3450	3550
30	1260	1470	-	-	4100	4250
36	1470	1470	1470	1890	4750	4900
42	1680	1890	-	-	5450	5650
48	1890	1890	-	1890	6100	6350
54	2100	2310	2310	-	6750	7050
60	2310	2310	-	-	7400	7700

*) External fuses

Rated voltage, kV	H, mm	H, mm *)
-12	2205	2355
-24	2495	2645
-36	2890	3040
-52	3300	3450

*) External fuses

QBANK-A; Large banks (12 + units)

Three racks, one per phase, mounted on top of each other with insulators in between, is a common arrangement for bank voltage up to 52 kV.

The maximum number of units is sixty. For higher voltages or more capacitor units, the phases of the bank are placed side-by-side. The racks are then placed on top of each other, with insulators in between, for each phase. Principally there is no limit in voltage, power or number of capacitor units for the QBANK-A type of capacitor bank (Figures 6 and 7).

QBANK is certified according to EMC directive 89/336/EEC.

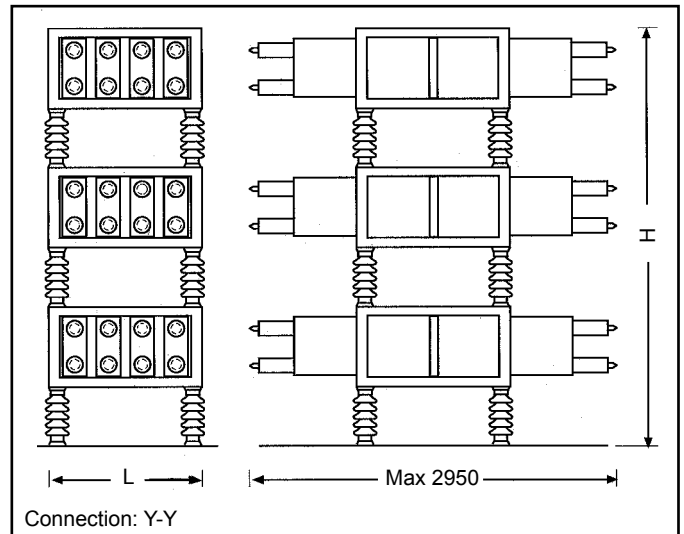

Fig. 6 QBANK-A, Internal fuses

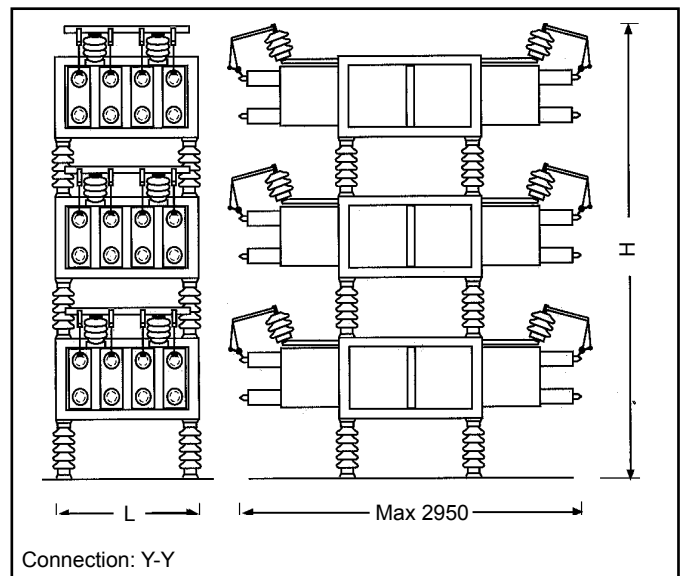

Fig. 7 QBANK-A, External fuses

Technical data and design can be subject to change and should be confirmed before ordering.

For more than seventy years, ABB Capacitors has manufactured power capacitors for small and large installations all over the world. ABB Capacitors in Ludvika bears overall responsibility for the capacitor business of the ABB Group.

ABB Capacitors is certified according to ISO 9001 (quality) and ISO 14001 (environment).

The product range of ABB Capacitors covers most types of capacitors for power applications, for instance:

- High voltage shunt banks
- Harmonic filters
- Series compensation
- Static var compensators
- High voltage direct current (HVDC) installations
- Capacitive voltage dividers (CVDs).



ABB Power Technologies
High Voltage Products/Capacitors
 SE-771 80 LUDVIKA, Sweden

Phone +46 240 78 20 00
 Fax +46 240 78 36 77

SECAP B03.en
 Edition 2, 2005-12