

Spare parts list
Ersatzteilliste
Liste de pièces de rechange
Catalogo parti di ricambio
Lista de piezas de recambio

M2QA 71-315

Three-phase induction motors with squirrel-cage rotors
Drehstrom-Asynchronmotoren mit Kurzschlussläufer
Moteurs asynchrones triphasés à cage
Motori asincroni trifase con rotore in corto circuito
Motores trifásicos asíncronos con rotor en cortocircuito



ABB

M2QA 71-315

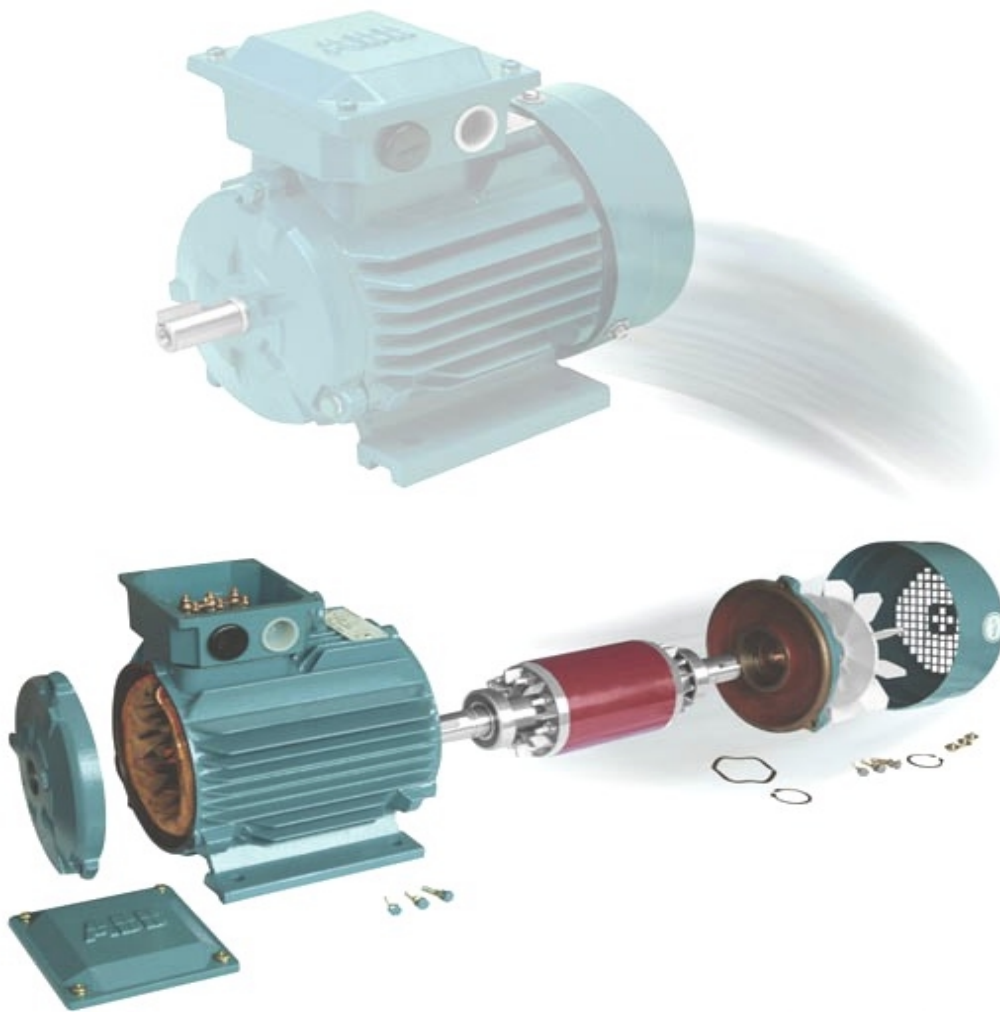

M2QA 71-315

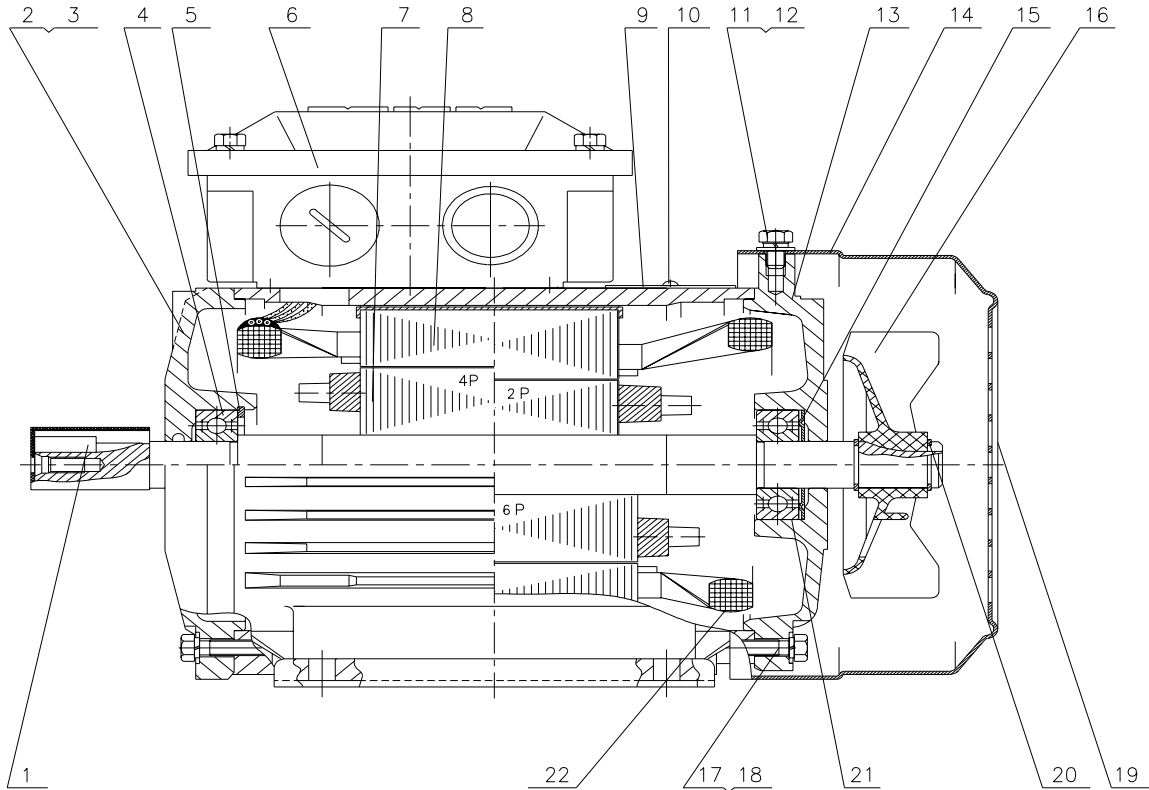

M2QA 71-315

1	Key Paßfeder Clavette Chiavetta Chaveta	6	Stator terminals complete Ständeranschluß komplett Bornes de raccordement complètes Morsettiera storica completa Terminales del estator completos
2	Endshield for D-end, IM 1001 Lagerschild, IM 1001 A-Seite Flasque palier côté commande, IM 1001 Tampa lado do veio, IM 1001 Scudo lato D, IM 1001 Escudo lado acople (IM 1001)	7	Stator, complete Ständer, komplett Stator, complet Statore, completo Estator, completo
3	Flanged end-shield for D-end, IM 3001 Flanschlagerschild, IM 3001 A-Seite Flasque palier bride côté commande, IM 3001 Flange IM 3001 Scudo flangiato lato D, IM 3001 Escudo brida (IM 3001)	8	Rotor with shaft Welle mit Läufer Rotor avec arbre Rotore con albero Rotor con eje
3A	D-end shield for flanged ring Flanschhalter Flasque palier porte bride Scudo porta anello (Flangia) Escudo porta-brida	9	Rating plate Leistungsschild Plaque signalétique Targhetta dati Placa de caracteristicas
3B	Flange (free holes) Flansch (Durchgangslöcher) Anneau bride (trous lisses) Anello (Flangia a fori passanti) Aro brida (agujeros pasantes)	10	Bolts Befestigungsschrauben Boulons Bulloni Tornillos
3C	Flange (tapped holes) Flansch (Gewindelöcher) Anneau bride (trous taraudés) Anello (Flangia a fori filettati) Aro brida (agujeros roscados)	11	Plug Stopfen Bouchon Tappo Tapon
4	Rolling bearing for D-end D-seitiges Wälzlager Palier de roulement de l'extrémité D Cuscinetto a rulli lato AS Cojinete del extremo D	12	Gasket Packung Boulons Guarnizione Junta
5	Locking ring Sicherungsring Circlip Anello de blocco Anillo retén	13	Endshield for N-end with screws N-seitiges Lagerschild mit Schrauben Flasque COC, avec vis Scudo cuscinetto lato NS, con viti Escudo de cojinete del extremo N con tornillos

M2QA 71-315

- | | | | |
|----|--|----|---|
| 15 | Spring washer, waved
Federnde Scheibe
Rondelle élastique
Rondelle elastico
Arandela flexible | 20 | Locking ring
Sicherungsring
Circlip
Anello de blocco
Anillo retén |
| 16 | Fan
Lüfter
Ventilateur
Ventola
Ventilador | 21 | Rolling bearing for N-end
N-seitiges Wälzlager
Palier de roulement de l'extrémité N
Cuscinetto a rulli lato NS Cojinete del extremo N |
| 17 | Plug
Stopfen
Bouchon
Tappo
Tapon | 22 | Material for stator winding,
complete
Material für die Ständerwicklung,
Komplett
Matériel pour enroulement
statorique,complete
Avvolgimenti statorici completi
Material para bobinado del estator,
completo |
| 18 | Gasket
Packung
Boulons
Guarnizione
Junta | | |
| 19 | Fan screen with screws
Lüfterhaube mit Schrauben
Capot ventilateur avec vis
Copriventola con viti
Grilla del ventilador, con tornillos | | |



ABB Logistics Center Europe GmbH
Bräukerweg 132
D-58708 Menden
Germany
<http://www.abb.com/motors&drives>

Spare parts list M2QA 71-315 2001-10
NOTE: Available electronic form only.