

Features

- Time relay RXKL 1 used as flasher relay
- Flashing frequency settable from 30 to 600 flashes per minute
- Suitable for signal systems where flashing operation is required
- Can replace all variants of phased-out flasher relays **RXSU 2** and **RXSU 4**.

Application

The RXKL 1 is a DC or AC voltage operated, high-precision, digital on-delay time relay utilizing a microprocessor for the time functions. The relay is described in Buyer's Guide 1MRK 508 002-BEN.

The time relay RXKL 1 is intended for use where high operation requirements are required, such as in protection systems, automation control systems, industrial processes, and control and signal systems. For application as flasher relay, the switch of RXKL marked K shall be set in the position for flashing function as described in section Setting.

To replace the phased-out flasher relays RXSU 2 or RXSU 4, connections according to the circuit diagrams in figures 1 or 2 shall be used. As shown in the diagrams, the RXSU-equivalent includes besides the time relay RXKL 1 also an off-delayed auxiliary relay RXMB 1. The RXMB contact 16-17 can be used to energize an other RXKL time relay if delayed alarm is required.

The connection according to Fig. 1 is recommended when the power of the lamps is maximum 20 W. The RXKL contacts are then expected to withstand more than 10 millions flashes.

In Fig. 2 an auxiliary relay RXME 1 with heavy duty contacts is added. That connection is recommended when the power of the lamps is above 20 W or when very long life-time is required. The RXME contacts are expected to withstand more than 30 millions operations.

Technical data for flashing operation (RXKL 1 +RXMB 1)

Rated voltage U_r	24, 48-55 V DC, 110-125 V AC/DC, 220-250 V DC and 220-240 V AC
Rated frequency	DC and 50-60Hz
Operating range	80-110% of U_r
Lamp power (all lamps together) Connection according to Fig. 1 Connection according to Fig. 2	Max 20 W Max 50 W
Mechanical life (average value) Connection according to Fig. 1 Connection according to Fig. 2	10 millions flashes 30 millions flashes
<i>Technical data for RXKL 1 see Buyer's Guide 1MRK 508 002-BEN</i> <i>Technical data for RXMB 1 see Buyer's Guide 1MRK 508 006-BEN</i> <i>Technical data for RXME 1 see Buyer's Guide 1MRK 508 015-BEN</i>	

Setting

The function and time settings are done by three rotary switches marked K, a and b.

To use the relay as a flasher relay, the switch K shall be set in the position marked with the symbol for pulses in direction 11 o'clock on the scale. The time scale factor is then 10 ms and the durations of each pulse and pause in the flash are the product of the scale factor and the sum of the set value a and b. The number of flashes per minute is equal to 60000 divided by two times set time in milliseconds. The highest setting is $a + b = 99$, which gives the time setting 990 ms and the relay will then do 30 flashes per minute. The shortest recommended time setting is $a + b = 5$, equal to 50 ms, which gives 600 flashes per minute. Standard flash frequencies for RXSU 2 and RXSU 4 were 40 and 100 flashes per minute. These flash frequencies correspond to the settings $a + b = 75$ and 30 respectively.

Connection

The connections shown in Fig. 1 and Fig. 2 are equivalent to the flasher relays RXSU 2 and RXSU 4. When one of the indicating contact closes, the relay RXMB 1 will be energized via the lamp and the relay will get enough voltage for operation but the lamp will remain dark. After set time the RXKL contacts will close and the lamp will get full voltage and RXMB will be short-circuited, but due to its off-delay it will not reset as long as any of the initiating contacts is closed.

Each lamp should have a rating of at least 1,5 W. A resistor can be connected in parallel with the lamp, then the flasher relay operates even if the lamp should fail.

Each of the relays in the circuit diagrams occupy one seat (2U 6C) in the COMBIFLEX mounting system.

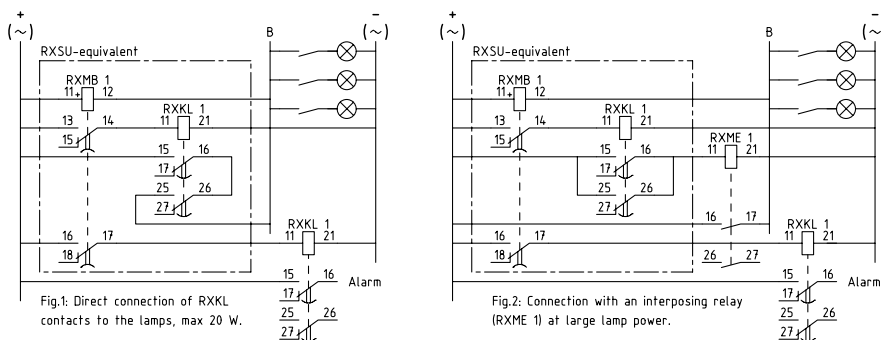

Mounting

The relay shall be mounted on separately ordered COMBIFLEX bases. For mounting details refer to the catalogue for mounting systems and parts

Ordering

Specify **RXKL 1:**

Quantity

Ordering No.

1MRK 000 066-AB for $U_r=24-250$ V DC/ $24-240$ V AC

Specify **RXME 1:**

Quantity

Ordering No.

RK 221 025-AD for $U_r=24$ V DC

RK 221 025-AH for $U_r=48-55$ V DC

RK 221 025-AN for $U_r=110-125$ V DC

RK 221 025-AS for $U_r=220-250$ V DC

Specify **RXMB 1:**

Quantity

Ordering No.

1MRK 001 107-AD for $U_r=24$ V DC

1MRK 001 107-AH for $U_r=48$ V DC

1MRK 001 107-DN for $U_r=110-125$ V AC/DC

1MRK 001 107-AS for $U_r=220-250$ V AC/DC

References

Time relay RXKL 1

1MRK 508 002-BEN

Auxiliary relay RXMB 1

1MRK 508 006-BEN

Auxiliary relay RXME 1

1MRK 508 015-BEN

COMBIFLEX connection and installation components

1MRK 513 003-BEN

Relay mounting system

1MRK 514 001-BEN