

CONNECTION AND SETTING GUIDE

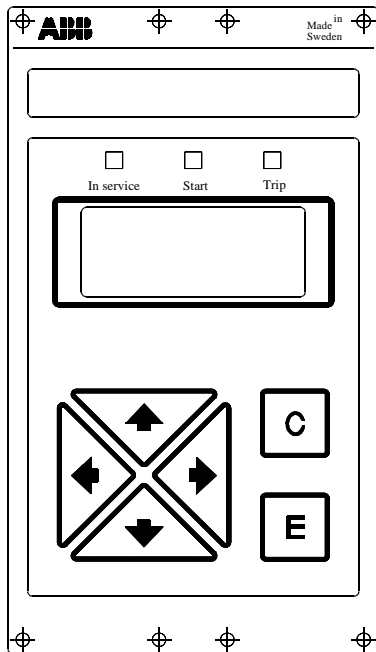

Front layout

General

The compact current relay RXHB 411 is available to order in four different versions, more information is available on page 4.

Location:	Partially weather protected locations, switchgear environment, class 3K3
Pressure:	80-106 kPa
Temperature:	-5° C to +55° C (permitted range) -40° C to +70° C (storage range)
Humidity:	10-90%
Ingress protection:	IP 44
Installation category:	III
Electric safety class:	II
Frequency:	50/60 Hz
Rated current:	I _r : 1 A or 5 A I _{Nr} : 30 mA, 0.1 A, 1.0 A or 5 A
Auxiliary voltage:	+/- 24 V (from DC/DC-converter)
Power consumption:	Maximum 5,5 W (without DC/DC-converter)
Binary-input:	48-60 V DC or 110-220 V DC
Binary-output:	Maximum voltage, 250 V AC/DC Current carrying capacity, continuous 5 A

Indications

LED indications:	Green LED indicates In service
	Yellow LED indicates Start
	Red LED indicates Trip

Without removing the plastic cover the primary service values and indications can be checked and cleared by pushing the “C” button.

Push button Let you...



1. Move upwards in menu tree.
2. Turn-off display at main menu.
3. Read service values and disturbance information.



1. Confirm choices in menu.
2. Move downwards in menu tree.



1. Move left in dialog boxes and editable menus.
2. Move upwards in menu tree.
3. Turn-off display at main menu.



1. Move right in dialog boxes and editable menus.
2. Move downwards in menu tree.



1. Move upwards in specific menu.
2. Increase editable values.
3. Select choice in dialog box and configuration.



1. Move downwards in specific menu.
2. Decrease editable values.
3. Select choice in dialog box and configuration.

MENU TREE OF RXHB 411

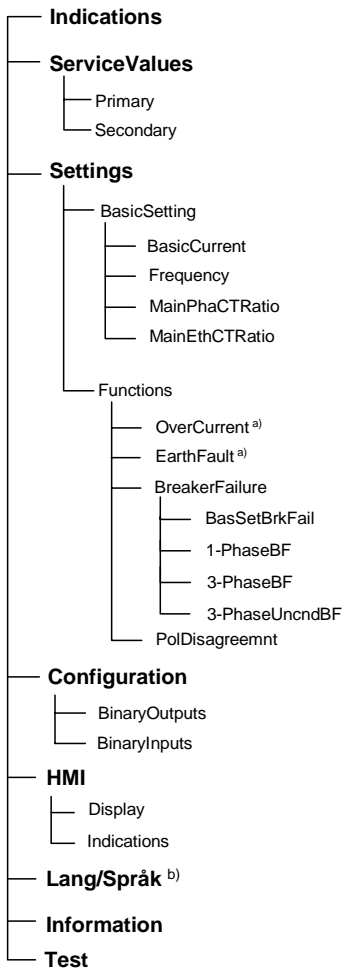

^{a)} Functions available as options

^{b)} English and the other available language is Swedish

Binary input functions:

Block or enable I>, I>>, I_N> and I_N>>^{a)}
 Single-phase start of breaker-failure protection
 Three-phase start of breaker-failure protection
 Three-phase unconditional start of breaker-failure protection
 Circuit-breaker out of order
 Block breaker-failure protection
 Block pole-disagreement protection
 Store actual service values
 Reset LED's and indications

Binary output functions:

Single-phase start and trip, I> and I>>^{a)}
 Multi-phase start and trip, I> and I>>^{a)}
 Start and trip, I_N> and I_N>>^{a)}
 Single-phase re-trip function
 Three-phase re-trip function
 Two three-phase back-up trip functions
 Pole-disagreement start and trip
 In service

Indications: The menu provides information about the recorded events.

- Unfilled squares for no recorded events (since last clearing).
- Filled grey squares for previous recorded event.
- Filled squares for latest recorded event.

Recorded events can be cleared by press and hold down the "C" for 2 seconds.

ServiceValues: This menu provides information of operating conditions.

- ServVal/Primary:** Primary system values.
- ServVal/Secondary:** Secondary system values.

Settings: Under this is menu the user set basic values, operate levels and time delays.

- BasSet/BasCurr:** Basic current.
- BasSet/Freq:** Rated relay frequency.
- BasSet/MainPhaCTR:** Ratio of main phase CT's.
- BasSet/MainEthCTR:** Ratio of main earth CT's.
- Func/OvCurr^{a)}:** Operate levels, times, etc.
- Func/EarthFl^{a)}:** Operate levels, times, etc.
- Func/BrkFail/BasSetBF:** Operate levels, times, etc.
- Func/BrkFail/1-PhBF:** Operate times, etc.
- Func/BrkFail/3-PhBF:** Operate times, etc.
- Func/BrkFail/3-PhUncBF:** Operate times, etc.
- Func/PolDisagreemnt:** Operate levels, times, etc.

Configuration: Under this is menu the user configure I/O signals.

- Config/BinOut:** Function to selected binary output with a mark.
- Config/BinIn:** Binary input signal to selected function with a mark.

HMI: Under this menu the user select the appearance of the display.

- HMI/Display:** Contrast level and turn-off or not.
- HMI/Indicat:** LED's to remain or not.

Lang/Språk: In this menu the user select language, English/Svenska.

Information: In this menu the user retrieve information of the relay, type, variant, options, etc.

Test: In this menu the user test the binary I/O signals during installation.

- BinOut:** Activate selected output by pressing "E".
- BinIn:** Binary input will be inverted when it's energized (RL voltage).

Saving dialogue: Appears when the user going upwards in the menu tree from a menu which consist editable values.

- YES:** Confirm the last setting(s) and exit.
- NO:** Confirm the previous setting(s) without any changes and exit.
- CANCEL:** Returns to the last setting(s) or to the last menu.

en0000648.vsd

WARNING AND NOTE SIGNS

The warning sign

The warning sign informs the user that certain operations should be avoided in order to prevent human injuries or damage to equipment.

The note sign

The note sign informs the user to be careful when using the product in certain situations and notifies the user to facts that could be of special interest during certain operations.



Warning!

Always avoid to touch the circuitry when the plastic cover, which covers the relay, is removed. The product contains electronic circuitries which can be damaged if exposed to static electricity (ESD). The electronic circuitries also contain high voltage which is lethal to humans.

Warning!

Never plug or withdraw a relay from the terminal base without blocking the output circuits or interrupting the auxiliary DC supply. Otherwise there is a risk of unwanted operations.

Warning!

Never disconnect a wire in a current circuit. Always be sure to short-circuit the secondary phase terminals of the current transformers to neutral before the circuit is opened. An opened current circuit will produce an extremely high voltage which is lethal to humans.



Note!

If the LED's are flashing or the green 'In service' LED is dark, an internal fault has occurred. Read the self supervision section in the technical reference manual for further information.

Note!

The compact current relay is designed for a maximum continuous current of four times rated value.

Note!

When the excitation characteristic of the CT is to be verified, the primary side of the CT must be an open-circuit and the secondary side disconnected from the relay protection.

Note!

The length of the functional-earth connection must be as short as possible when connecting to EMC-earth. Withstand against electrical disturbances could otherwise be hazarded.

CONNECTION AND TERMINAL DIAGRAMS

Connection

RXHB 411 requires a DC/DC-converter for auxiliary voltage supply +/- 24 V; RXTUG 22H is recommended. The relay is delivered with 4 short-circuiting connectors RTXK for mounting on the rear of the terminal base. The connectors will automatically short-circuit the current inputs when the relay is removed from the terminal base.

Terminal diagrams

The relay is available in four versions excluding the transformer combinations. The versions and there terminal diagrams are shown below.

RXHB 411	Basic version, terminal diagram figure 1
RXHB 411	Basic version together with overcurrent and earth-fault protection, terminal diagram figure 1
RXHB 411	Basic version together with binary I/O option, terminal diagram figure 2
RXHB 411	Basic version together with overcurrent, earth-fault protection and binary I/O option, terminal diagram figure 2

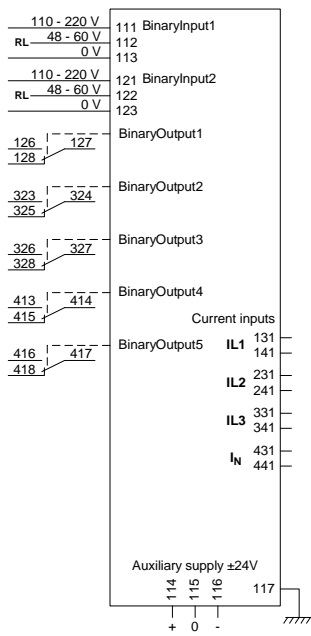

99000444.vsd

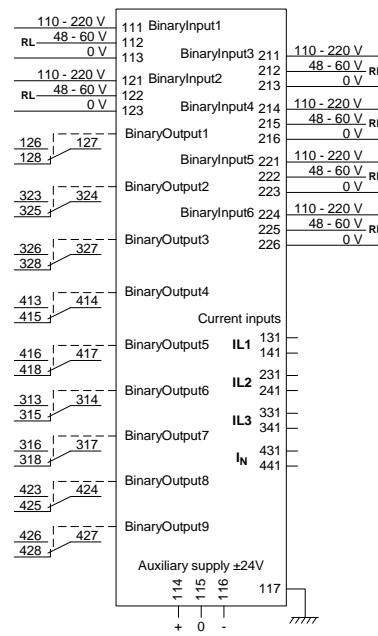

99000445.vsd

Figure 1: RXHB 411 basic version

Figure 2: RXHB 411 with binary I/O option