

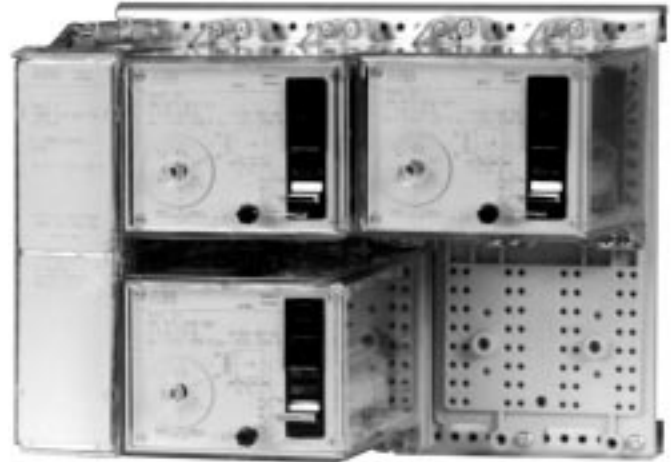

(SE970176)



(SE970889)

Features

- Single-, two- and three-phase versions for short-circuit and earth fault protection
- Versions with or without time-lag relay
- Test switch and trip indication included as standard
- Versions with heavy- and medium-duty trip output
- Twelve current ranges provide a total setting range of 2,5 mA to 45 A
- High reset ratio enables a setting close to maximum service values
- High continuous current carrying capacity
- Low transient overreach i.e. relay is insensitive to dc component in fault current (RXIG 21 and RXIG 22)
- Very low burden on current transformer enables use of RXIG on small cores and as very sensitive current protection e.g. as capacitor bank unbalance or earth fault protection in high ohmic earthed systems
- Three versions of RXIG are available
 - RXIG 21 with straight frequency characteristic
 - RXIG 22 which has reduced sensitivity to higher frequencies
 - RXIG 28 with extra low ac power consumption

Application

The instantaneous and time delayed overcurrent protections with RXIG are used in a number of different applications, such as:

Short-circuit protection

Two- and three-phase, instantaneous and definite time delayed versions are available for use as short-circuit protection on all type of objects. The low transient overreach and short reset time ensures suitability for most applications. For such applications RXIG 21 is normally used, however, in special applications such as short-circuit protection on

capacitor banks, where high frequency inrush currents must be suppressed, RXIG 22 is selected as the measuring relay.

Instantaneous versions are used for motors, as high set stage on transformers and as high set stage on capacitor banks. A version with release input can be used as stub protection in 1¹/₂ CB stations.

Application (cont'd)

Earth fault protection

Single-phase, definite time delayed assemblies are used as earth fault protection for unearthed, high ohmic earthed or directly earthed systems, when definite time delay is required.

For unearthed and high ohmic earthed systems it must be checked that back feed of capacitive current at fault on a parallel object will not cause nonselective operation. For such cases directional earth fault relays must be used.

A version with two definite time delayed steps is available for use as stand-by earth fault protection in a transformer or an earthing transformer neutral.

For applications where a very sensitive relay, with setting ranges down to 2,5 mA secondary is required, the RXIG 28 measuring relay can be selected. RXIG 28 has extremely low power consumption in the measuring circuit (<0,3 mVA) and will thus give a high efficiency factor.

RXIG assemblies for earth fault protection are provided with release input, where neutral point overcurrent protection can be connected to prevent problems with stray residual currents, caused by a small unsymmetry of the three current transformers e.g. at short-circuits.

This release must be used when the sensitive earth fault relay is fed from three residual connected phase CT's.

Capacitor bank unbalance protection

A two-stage (or one-stage) assembly with RXIG 22 is used as unbalance protection for capacitor banks. RXIG 22 is used to prevent problems due to high frequency components occurring at switching of high voltage or parallel connected capacitor banks.

Generator interturn short-circuit protection

For generators with split winding or for twin-generators, an interturn fault protection can be arranged by measuring the occurring unbalance current between the two neutral stars.

Due to the occurring third harmonic current in the circuit, both during normal service and during external short-circuits, RXIG 22 should be selected as the measuring relay.

Blockable overcurrent relays for busbar protection

Special versions are available for use as busbar protection on distribution buses, with infeed of fault current from one direction only. For distribution buses a quick tripping for busbar faults can be achieved with a short-circuit protection in the incoming bay having a short-time delayed step (150 ms) blocked from start of overcurrent protection on outgoing bays.

Special applications

With the three available versions of simple ac over- or undercurrent relay, RXIG is suitable for use in special applications such as blocking of tap changer regulation, forming negative sequence overcurrent protection together with a filter, providing open CT supervision together with high impedance differential protection etc.

Design

The overcurrent protections **RAIG** are built up based upon the overcurrent relay RXIG 2. RAIG is available in several versions, with and without time-lag relay and with different duty on trip outputs.

All versions are equipped with test switch, RTXP 18, for simple secondary testing, and most of them with output relay with red trip flag indicator. The trip flag is hand reset.

The current measuring relay type **RXIG** is a static, instantaneous ac current relay which can be used as over- or undercurrent protec-

tion. The relay consists mainly of an input voltage transformer (for isolation), rectifier and filter, auxiliary voltage regulator and potentiometer which provides an adjustable reference voltage, level detector and an amplifier which drives an electromechanical output relay.

The output relay is equipped with 2-medium duty change-over contacts and with a yellow flag which can be hand-reset via a knob on the front cover. A flag-locking strip is provided and is to be removed when indication of RXIG instantaneous operation is required.

A red flag is available and exchange can be performed by the user, when red trip indication is required.

The set operating value on RXIG is determined by the scale factor ordered and by the setting on a continuously adjustable 1 to 3 scale calibration. The desired operating value is set by turning the scale knob with a screwdriver until the appropriate figure lies immediately opposite the maximum or minimum mark for overcurrent or undercurrent, respectively.

A short-circuiting connector, type RTXK, is supplied with the relay. This connector is mounted on the rear of the terminal base and will automatically short-circuit current input when the relay is removed from the terminal base.

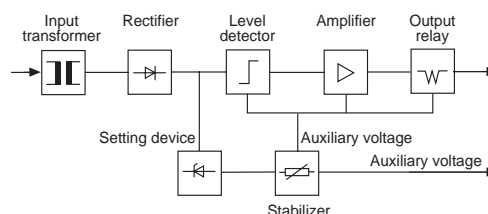

Fig. 1 Block diagram of RXIG

Technical data

The table below is for measuring relays RXIG 21, RXIG 22 and RXIG 28. For data of protection please refer to catalogues for time- and auxiliary relays.

Table 1: Energizing quantities, rated values and limits

Type	RXIG 21	RXIG 22	RXIG 28
Rated frequency	50-60 Hz	50 Hz or 60 Hz	50-60 Hz
Total scale ranges (Multiple models, see Ordering)	10 mA-45 A	10 mA-7,5 A	2,5 mA-75 mA
Auxiliary voltage EL	24 and 48-60 V DC or 110-125 and 220-250 V DC		
Operate time at instantaneous current change from 0 to			
1,1 x set value ms	60	110	140
2,5 x set value ms	35	55	55
Reset ratio	> 97%	> 97%	> 97%
Reset time at instantaneous current change to 0 from			
1,1 x set value ms	55	45	55
Consistency of operate value	< 1	< 1	< 1
Graduation error in % of set value	< 5	< 5	< 5
Percent change in operate current:		At n x rated frequency	At n x rated frequency
at frequency change	0,05% per Hz	n =	n =
within the frequency range	(45-300 Hz)	2 3 5	2 3 5
		+200% +400% +600%	+20% +40% +110%
per C° temperature change	< 0,07%	< 0,07%	< 0,09%
per % auxiliary voltage change	0,04%	0,04%	0,04%
Permitted auxiliary voltage deviation	-20% to +10%	-20% to +10%	-20% to +10%
Transient overreach at lowest/highest setting%	1/1 at τ = 100 ms	1/2 at τ = 100 ms	11/20 at τ = 100 ms

Technical data (cont'd) **Table 1: Energizing quantities, rated values and limits**

Type	RXIG 21		RXIG 22		RXIG 28	
Permitted service ambient temperature	-25°C to +55°C		-25°C to +55°C		-25°C to +55°C	
Power consumption Auxiliary voltage circuit at rated dc voltage	Before operation W	At operation W	Before operation W	At operation W	Before operation W	At operation W
24 V	0,5	1,2	0,5	1,2	0,5	1,2
48/60 V	1,4/2,2	2,1/3,4	1,4/2,2	2,1/3,4	1,4/2,2	2,1/3,4
110/125 V	1,0/1,3	1,6/2,0	1,0/2,2	1,6/2,0	1,0/1,3	1,6/2,0
220/250 V	2,2/2,9	2,8/3,7	2,2/2,9	2,8/3,7	2,2/2,9	2,8/3,7
Power consumption Measuring circuit at current = lowest setting (power factor ≈ 1)		mVA		mVA		mVA
	10 mA-0,5 A	7	10 mA-0,5 A	3,5	0,25-100 mA	0,3
	1 A	15	1 A	5		
	2,5 A	30	2,5 A	15		
	5 A	110				
Overload capacity n x lowest setting						
continuous (max 20 A)	n=30		n=40		n=400	
1 second (max 350 A)	n=850		n=1700		n=8000	

Table 2: Contacts

Type	RXIG 21, RXIG 22, RXIG 28
Number of contacts	2 change-over
Max. system voltage dc/ac	300/250 V
Current carrying capacity (for already closed contact) 200 ms/1 s continuously	90/50 A 5 A
Making and conducting capacity L/R > 10 ms, 200 ms/1 s	30/10 A
Breaking capacity ac PF > 0,1 max 250 V	10 A
dc L/R < 40 ms 48/110 V 125/220 V 250 V	1,5/0,4 A 0,3/0,2 A 0,15 A

Table 3: Electromagnetic compatibility tests

Power frequency test (SS 436 15 03)	0,5 kV, class PL 4
Fast transient test (SS 436 15 03)	4-8 kV, class PL 4
1 MHz burst test (IEC 60255-22-1)	2,5 kV, class III
Electrostatic discharge test (IEC 60255-22-2)	15 kV, class IV
Radiated electromagnetic field test (IEC 61000-4-3)	10 V/m, 26-1000 MHz, class III
Conducted electromagnetic test (IEC 61000-4-6)	10 V, 0,15-80 MHz
Fast transient test (IEC 60255-22-4)	4 kV, class IV
Emissivity test (EN 55 011)	0,15-100 MHz, class A

Table 4: Insulation tests (IEC 60255-5)

Dielectric tests current circuit other circuits	2,5 kV 50 Hz, 1 min 2,0 kV 50 Hz, 1 min
Impulse voltage test	5,0 kV, 1,2/50 μ s, 0,5 J

Dimensions and mounting

The RXIG 21 (22, 28) measuring relay occupies two COMBIFLEX seats (2U 12C) The relay is mounted on a separately ordered COMBIFLEX base, mounted on an apparatus frame, in an equipment frame, or on apparatus bars which are mounted on a support frame in an equipment frame.

The assemblies are provided on apparatus bars, with different sizes, for mounting on support frame in a 4U, 19" equipment frame or in cases type RHGX 8, 12 or 20 for panel flush or semi-flush mounting.

For mounting details refer to COMBIFLEX catalogue.

All assemblies can be delivered in the following mounting alternatives:

- on apparatus bar
- in equipment frame
- in RHGS
- in RHGX

Diagrams

Below, some examples of terminal diagrams for different versions of current protections are shown. Terminal diagrams (TD) are simplified, space saving diagrams, intended for use in plant circuit diagrams.

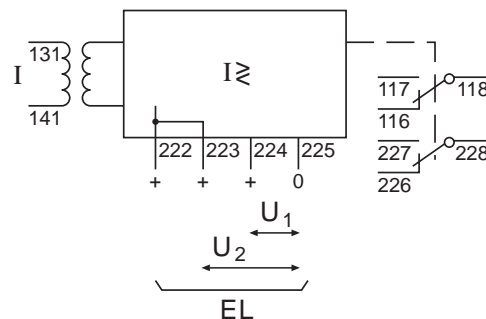

Fig. 2 Circuit diagram for RXIG 2

Diagrams shown below are available on request. Circuit diagrams (CD) are also available for all assemblies, as given in ordering table below.

The auxiliary voltage EL is always applied to terminals 222 and 225. For auxiliary voltage U1 of 24 or 110-125 V dc, terminals 223 and 224 are to be joined.

Diagrams (cont'd)

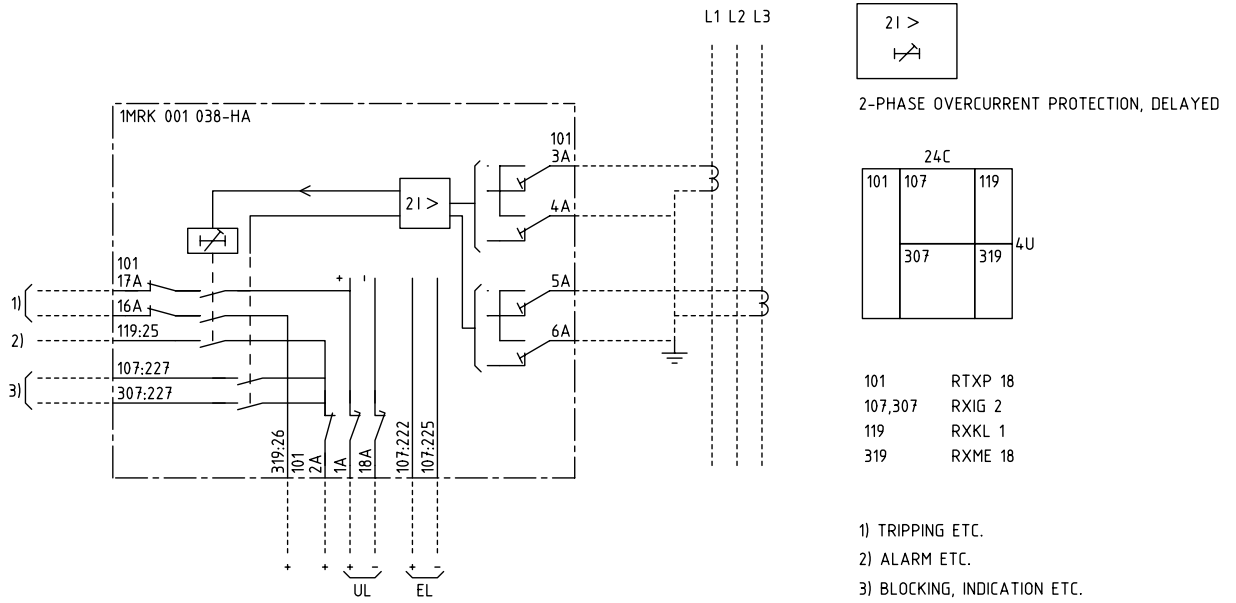

Fig. 3 Terminal diagram No. 1MRK 001 038-HAA for RAIG, 1MRK 001 037-HA

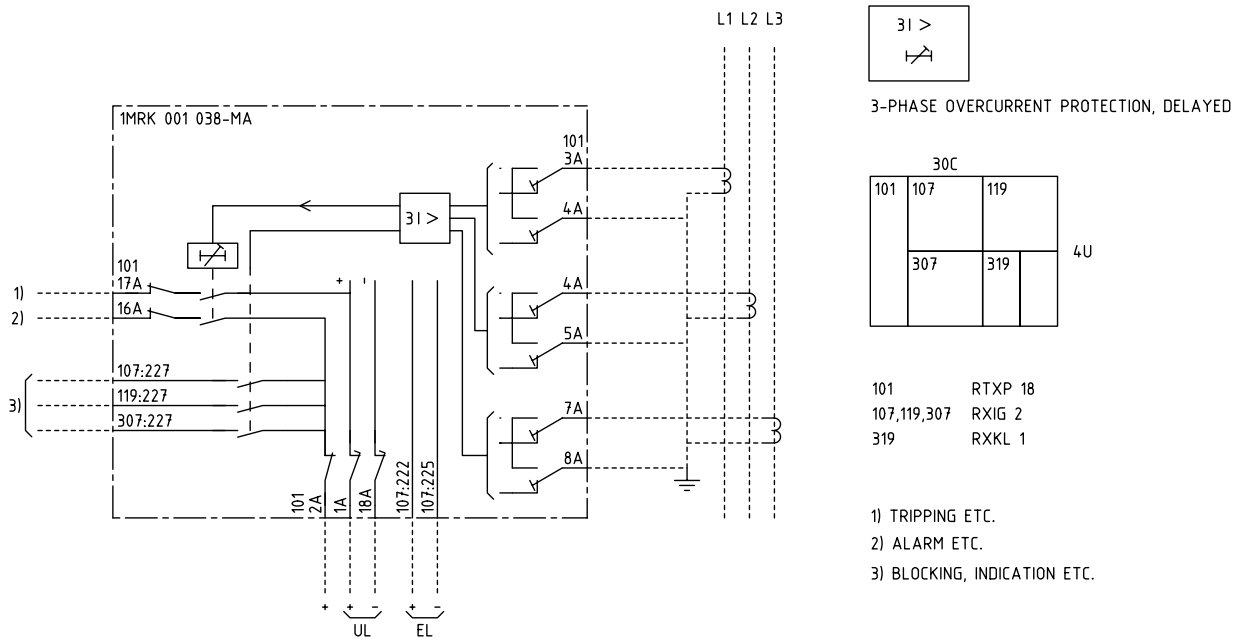

Fig. 4 Terminal diagram No. 1MRK 001 038-MAA for RAIG, 1MRK 001 037-MA

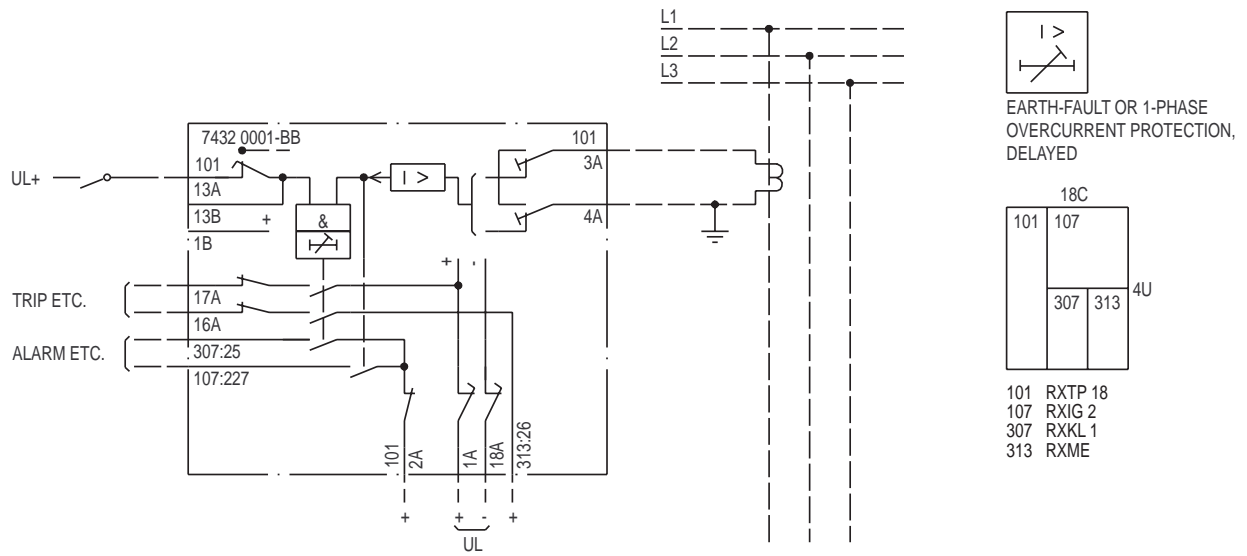

Fig. 5 Terminal diagram No. 7432 0001-BBA for RAIG, RK 651 100-BB

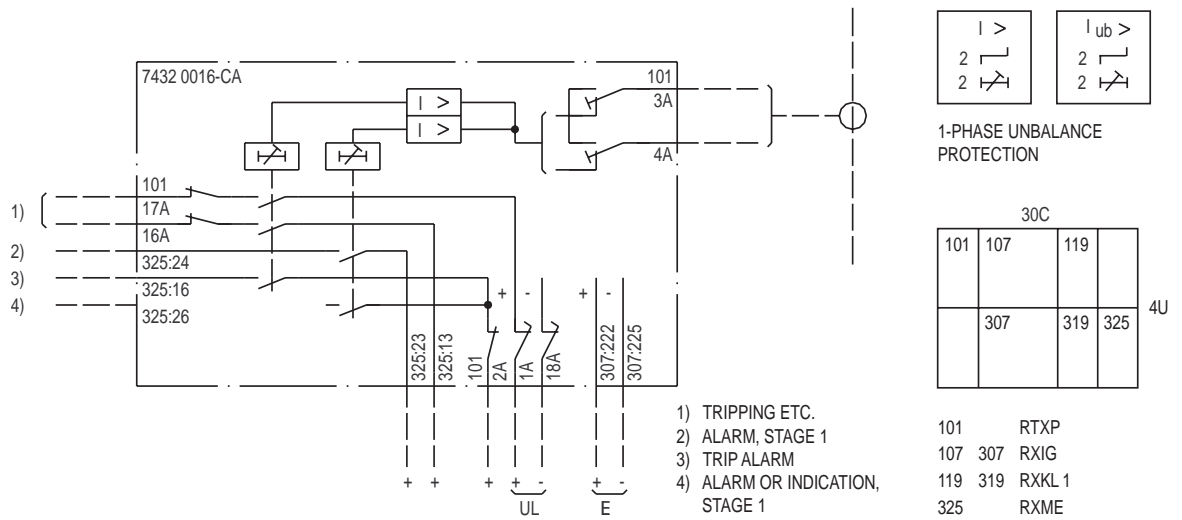

Fig. 6 Terminal diagram No. 7432 0016-CAA for RAIG, RK 651 116-CA

Ordering

Ordering table for Protections RAIG

Version	Time delay	Output relay	Circuit/Terminal diagram No.	Ordering No.
I >	RXKL 1	–	1MRK 001 038-CA/ -CAA	1MRK 001 037-CA
I >	RXKL 1	RXME 18	1MRK 001 038-DA/ -DAA	1MRK 001 037-DA
2I >	RXKL 1	–	1MRK 001 038-GA/ -GAA	1MRK 001 037-GA
2I >	RXKL 1	RXME 18	1MRK 001 038-HA/ -HAA ¹⁾	1MRK 001 037-HA
3I >	RXKL 1	–	1MRK 001 038-MA/ -MAA ¹⁾	1MRK 001 037-MA
3I >	RXKL 1	RXME 18	1MRK 001 038-NA/ -NAA	1MRK 001 037-NA
3I >	RXKL 1	RXME 18	7431 0011-BB/BBA	RK 651 010-BB
3I >	RXKL 1	RXSF 1	7431 0011-CB/ -CBA	RK 651 010-CB
3I >	RXKL 1	RXMVB 2	7431 0104-BA/ -BAA	RK 651 013-BA
I \downarrow	2 RXKL 1	RXME 1, RXSF 1	7432 0109-AA/AAA	RK 651 024-AA
I \downarrow or I _{ub}	RXKL 1	RXME 18	7432 0001-BB/ -BBA ¹⁾	RK 651 100-BB
I \downarrow	RXKL 1	RXSF 1	7432 0001-CB/ -CBA	RK 651 100-CB
I \downarrow	–	RXME 1	7432 0005-BA/ -BAA	RK 651 115-BA
I _{ub} 2-stage	2 RXKL 1	RXSF 1	7432 0016-CA/ -CAA ¹⁾	RK 651 116-CA

¹⁾ Diagram shown in this document. Other diagrams available on request.

Specify:

- RAIG protections
- Quantity
- Ordering number
- Code A H M
- Desired wording on the lower half of the test switch face plate max. 13 lines with 14 characters per line.
- RXIG loose relays
- Quantity
- Ordering number

Overcurrent relay for 24, 48-60 V dc

Scale	RXIG 21	Code	RXIG 22, 50 Hz	Code	RXIG 22, 60 Hz	Code	RXIG 28	Code
2,5-7,5mA	–		–		–		RK 411 003-DD	<input type="checkbox"/> A53
5-15 mA	–		–		–		RK 411 003-DE	<input type="checkbox"/> A54
10-30 mA	RK 411 001-DA	<input type="checkbox"/> A1	RK 411 005-DA	<input type="checkbox"/> A21	RK 411 007-DA	<input type="checkbox"/> A37	RK 411 003-DF	<input type="checkbox"/> A55
25-75 mA	RK 411 001-DB	<input type="checkbox"/> A2	RK 411 005-DB	<input type="checkbox"/> A22	RK 411 007-DB	<input type="checkbox"/> A38	RK 411 003-DG	<input type="checkbox"/> A56
50-150 mA	RK 411 001-DC	<input type="checkbox"/> A3	RK 411 005-DC	<input type="checkbox"/> A23	RK 411 007-DC	<input type="checkbox"/> A39	–	
0,1-0,3 A	RK 411 001-DD	<input type="checkbox"/> A4	RK 411 005-DD	<input type="checkbox"/> A24	RK 411 007-DD	<input type="checkbox"/> A40	–	
0,25-0,75 A	RK 411 001-DE	<input type="checkbox"/> A5	RK 411 005-DE	<input type="checkbox"/> A25	RK 411 007-DE	<input type="checkbox"/> A41	–	
0,5-1,5 A	RK 411 001-DF	<input type="checkbox"/> A6	RK 411 005-DF	<input type="checkbox"/> A26	RK 411 007-DF	<input type="checkbox"/> A42	–	
1-3 A	RK 411 001-DG	<input type="checkbox"/> A7	RK 411 005-DG	<input type="checkbox"/> A27	RK 411 007-DG	<input type="checkbox"/> A43	–	
2,5-7,5 A	RK 411 001-DH	<input type="checkbox"/> A8	RK 411 005-DH	<input type="checkbox"/> A28	RK 411 007-DH	<input type="checkbox"/> A44	–	
5-15 A	RK 411 001-DK	<input type="checkbox"/> A9	–		–		–	
15-45 A	RK 411 001-DL	<input type="checkbox"/> A10	–		–		–	

Overcurrent relay for 110-125, 220-250 V dc

Scale	RXIG 21	Code	RXIG 22, 50 Hz	Code	RXIG 22, 60 Hz	Code	RXIG 28	Code
2,5-7,5 mA	–		–		–		RK 411 004-DD	<input type="checkbox"/> A57
5-15 mA	–		–		–		RK 411 004-DE	<input type="checkbox"/> A58
10-30 mA	RK 411 002-DA	<input type="checkbox"/> A11	RK 411 006-DA	<input type="checkbox"/> A29	RK 411 008-DA	<input type="checkbox"/> A45	RK 411 004-DF	<input type="checkbox"/> A59
25-75 mA	RK 411 002-DB	<input type="checkbox"/> A12	RK 411 006-DB	<input type="checkbox"/> A30	RK 411 008-DB	<input type="checkbox"/> A46	RK 411 004-DG	<input type="checkbox"/> A60
50-150 mA	RK 411 002-DC	<input type="checkbox"/> A13	RK 411 006-DC	<input type="checkbox"/> A31	RK 411 008-DC	<input type="checkbox"/> A47	–	
0,1-0,3 A	RK 411 002-DD	<input type="checkbox"/> A14	RK 411 006-DD	<input type="checkbox"/> A32	RK 411 008-DD	<input type="checkbox"/> A48	–	
0,25-0,75 A	RK 411 002-DE	<input type="checkbox"/> A15	RK 411 006-DE	<input type="checkbox"/> A33	RK 411 008-DE	<input type="checkbox"/> A49	–	
0,5-1,5 A	RK 411 002-DF	<input type="checkbox"/> A16	RK 411 006-DF	<input type="checkbox"/> A34	RK 411 008-DF	<input type="checkbox"/> A50	–	
1-3 A	RK 411 002-DG	<input type="checkbox"/> A17	RK 411 006-DG	<input type="checkbox"/> A35	RK 411 008-DG	<input type="checkbox"/> A51	–	
2,5-7,5 A	RK 411 002-DH	<input type="checkbox"/> A18	RK 411 006-DH	<input type="checkbox"/> A36	RK 411 008-DH	<input type="checkbox"/> A52	–	
5-15 A	RK 411 002-DK	<input type="checkbox"/> A19	–		–		–	
15-45 A	RK 411 002-DL	<input type="checkbox"/> A20	–		–		–	

Auxiliary voltage

Mainly for included (auxiliary relays)

	Code
24 V dc	<input type="checkbox"/> H5
48-55 V dc	<input type="checkbox"/> H6
110-125 V dc	<input type="checkbox"/> H7
220-250 V dc	<input type="checkbox"/> H8

Mounting

Mounting alternatives	Size	Article No.	Code
Apparatus bars			<input type="checkbox"/> M10
Equipment frame without door	4U 19"	1MRK 000 137-GA	<input type="checkbox"/> M11
Equipment frame with door	4U 19"	1MRK 000 137-KA	<input type="checkbox"/> M12
RHGX 4	4U 12C	RK 927 001-AB	<input type="checkbox"/> M71
RHGX 8	4U 24C	RK 927 002-AB	<input type="checkbox"/> M72
RHGX 12	4U 36C	RK 927 003-AB	<input type="checkbox"/> M73
RHGX 20	4U 60C	RK 927 004-AB	<input type="checkbox"/> M74
RHGS 30	6U x 1/1 19" rack	1MRK 000 315-A	<input type="checkbox"/> M81
RHGS 12	6U x 1/2 19" rack	1MRK 000 315-B	<input type="checkbox"/> M82
RHGS 6	6U x 1/4 19" rack	1MRK 000 315-C	<input type="checkbox"/> M83

References

Auxiliary relays	1MRK 508 015-BEN
Time relays	1MRK 508 016-BEN
Current and voltage relays	1MRK 508 018-BEN
Parts in COMBIFLEX	1MRK 513 004-BEN
Plug-in COMBIFLEX	1MRK 513 004-BEN
Test system COMBITEST	1MRK 512 006-BEN

Manufacturer

ABB Automation Products AB
Substation Automation Division
SE-721 59 Västerås
Sweden
Tel: +46 (0) 21 342000
Fax: +46 (0) 21 146918